

M38C29T-ADF

Temporary Target Board for M38C29RLFS

User's Manual

Keep safety first in your circuit designs!

- Renesas Technology Corporation and Renesas Solutions Corporation put the maximum effort into making semiconductor products better and more reliable, but there is always the possibility that trouble may occur with them. Trouble with semiconductors may lead to personal injury, fire or property damage. Remember to give due consideration to safety when making your circuit designs, with appropriate measures such as (i) placement of substitutive, auxiliary circuits, (ii) use of nonflammable material or (iii) prevention against any malfunction or mishap.

Notes regarding these materials

- These materials are intended as a reference to assist our customers in the selection of the Renesas Technology product best suited to the customer's application; they do not convey any license under any intellectual property rights, or any other rights, belonging to Renesas Technology Corporation, Renesas Solutions Corporation or a third party.
- Renesas Technology Corporation and Renesas Solutions Corporation assume no responsibility for any damage, or infringement of any third-party's rights, originating in the use of any product data, diagrams, charts, programs, algorithms, or circuit application examples contained in these materials.
- All information contained in these materials, including product data, diagrams, charts, programs and algorithms represents information on products at the time of publication of these materials, and are subject to change by Renesas Technology Corporation and Renesas Solutions Corporation without notice due to product improvements or other reasons. It is therefore recommended that customers contact Renesas Technology Corporation, Renesas Solutions Corporation or an authorized Renesas Technology product distributor for the latest product information before purchasing a product listed herein. The information described here may contain technical inaccuracies or typographical errors. Renesas Technology Corporation and Renesas Solutions Corporation assume no responsibility for any damage, liability, or other loss rising from these inaccuracies or errors. Please also pay attention to information published by Renesas Technology Corporation and Renesas Solutions Corporation by various means, including the Renesas home page (<http://www.renesas.com>).
- When using any or all of the information contained in these materials, including product data, diagrams, charts, programs, and algorithms, please be sure to evaluate all information as a total system before making a final decision on the applicability of the information and products. Renesas Technology Corporation and Renesas Solutions Corporation assume no responsibility for any damage, liability or other loss resulting from the information contained herein.
- Renesas Technology semiconductors are not designed or manufactured for use in a device or system that is used under circumstances in which human life is potentially at stake. Please contact Renesas Technology Corporation, Renesas Solutions Corporation or an authorized Renesas Technology product distributor when considering the use of a product contained herein for any specific purposes, such as apparatus or systems for transportation, vehicular, medical, aerospace, nuclear, or undersea repeater use.
- The prior written approval of Renesas Technology Corporation and Renesas Solutions Corporation is necessary to reprint or reproduce in whole or in part these materials.
- If these products or technologies are subject to the Japanese export control restrictions, they must be exported under a license from the Japanese government and cannot be imported into a country other than the approved destination. Any diversion or reexport contrary to the export control laws and regulations of Japan and/or the country of destination is prohibited.
- Please contact Renesas Technology Corporation or Renesas Solutions Corporation for further details on these materials or the products contained therein.

Precautions to be taken when using this product

- This product is a development supporting unit for use in your program development and evaluation stages. In mass-producing your program you have finished developing, be sure to make a judgment on your own risk that it can be put to practical use by performing integration test, evaluation, or some experiment else.
- In no event shall Renesas Solutions Corporation be liable for any consequence arising from the use of this product.
- Renesas Solutions Corporation strives to renovate or provide a workaround for product malfunction at some charge or without charge. However, this does not necessarily mean that Renesas Solutions Corporation guarantees the renovation or the provision under any circumstances.
- This product has been developed by assuming its use for program development and evaluation in laboratories. Therefore, it does not fall under the application of Electrical Appliance and Material Safety Law and protection against electromagnetic interference when used in Japan.



CAUTION

If the requirements shown in the "CAUTION" sentences are ignored, the equipment may cause personal injury or damage to the products.

Renesas Tools Homepage <http://www.renesas.com/en/tools>

1. Things to Check When Unpacking

The M38C29T-ADF package consists of the following products. When unpacking your package, check to see that all of these components are included.

If you find any item missing or faulty, or any suggestion, contact your local distributor.

Table 1.1 Package components

Item
M38C29T-ADF temporary target board
M38C29T-ADF User's Manual (this manual)

2. Outline

The M38C29T-ADF is a temporary target board used to develop software with a compact emulator M38000T2-CPE or PC4701 emulator system. It supplies to the M38C29RLFS MCU the minimum required signals needed to operate the emulator MCU, including power supply voltage, clock signals and reset signals. Use it when the user system is not ready.

3. Specifications

Table 3.1 lists the specifications of the M38C29T-ADF.

Table 3.1 Specifications

Applicable MCU	M38C29RLFS	
Clock	4.0MHz oscillator mounted (oscillator circuit board OSC-2 used) 32.768kHz (can be disconnected by SW1)	
Vcc	Supplied separately*	
Vss	Supplied separately	
RESET	- Reset circuit mounted (power-on reset and reset switch) - Connects the reset output of an emulation pod	
External dimensions	Width	90mm
	Depth	115mm
Others	Universal part prepared	

* Power cannot be supplied from the emulator (e.g. M38000T2-CPE). A separate power supply is needed.

4. Setting Up

This chapter describes how to set up the M38C29T-ADF.

- (1) Mount the emulator MCU on the M38C29T-ADF.
After checking the position of the No. 1 pin of the emulator MCU, mount the emulator MCU referencing Figure 4.1.
- (2) Insert the connector on the tip of the emulator probe to the socket on the emulator MCU.
For the M38000T2-CPE, the converter board PCA4933 is required between the emulator probe and emulator MCU.

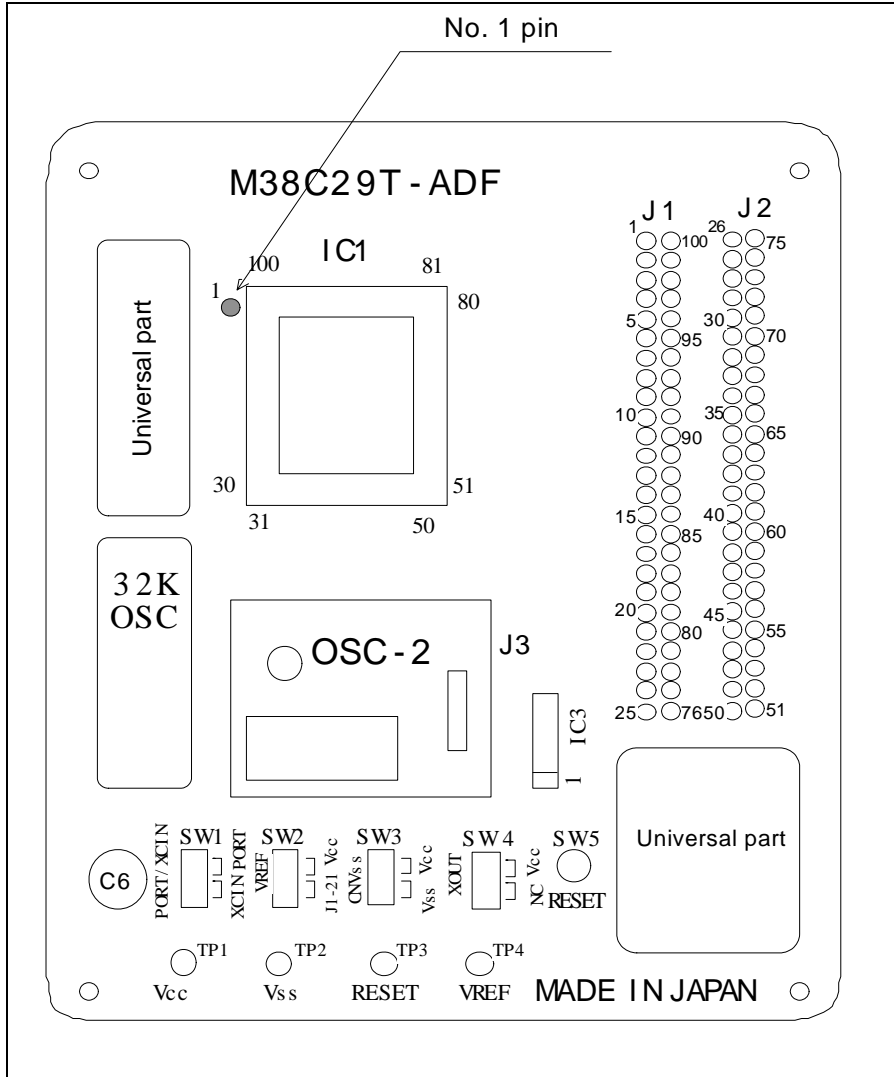

Figure 4.1 Position of No. 1 pin of the M38C29T-ADF's emulator MCU

⚠ CAUTION

Cautions to Be Taken for This Product:



- Always shut OFF power before connecting this product. The power ON state could destroy internal circuit.

- (3) Connect the RESET cable (white) and the GND cable (black) of the emulation pod to the RESET (TP3) pin and Vss (TP2) pin of the M38C29T-ADF respectively. And connect the Vcc cable (red) to the Vcc (TP1) pin.
- (4) Set the MCU type select switch of the M3800T2-CPE to the RLSS side.
- (5) Connect a power supply (not included) to the Vcc (TP1) pin of the M38C29T-ADF. And connect the GND output of the power supply to the Vss (TP2) pin. Use the power supply whose rising time is 10ms or less.

Table 4.1 lists the correspondence of the connector cables and signals, and Figure 4.2 shows the connection pattern.

Table 4.1 Connector cables of the M3800T2-CPE and applicable signals

Cable color	Signal
WHITE	RESET
BLACK	Vss
RED	Vcc (SENSE)

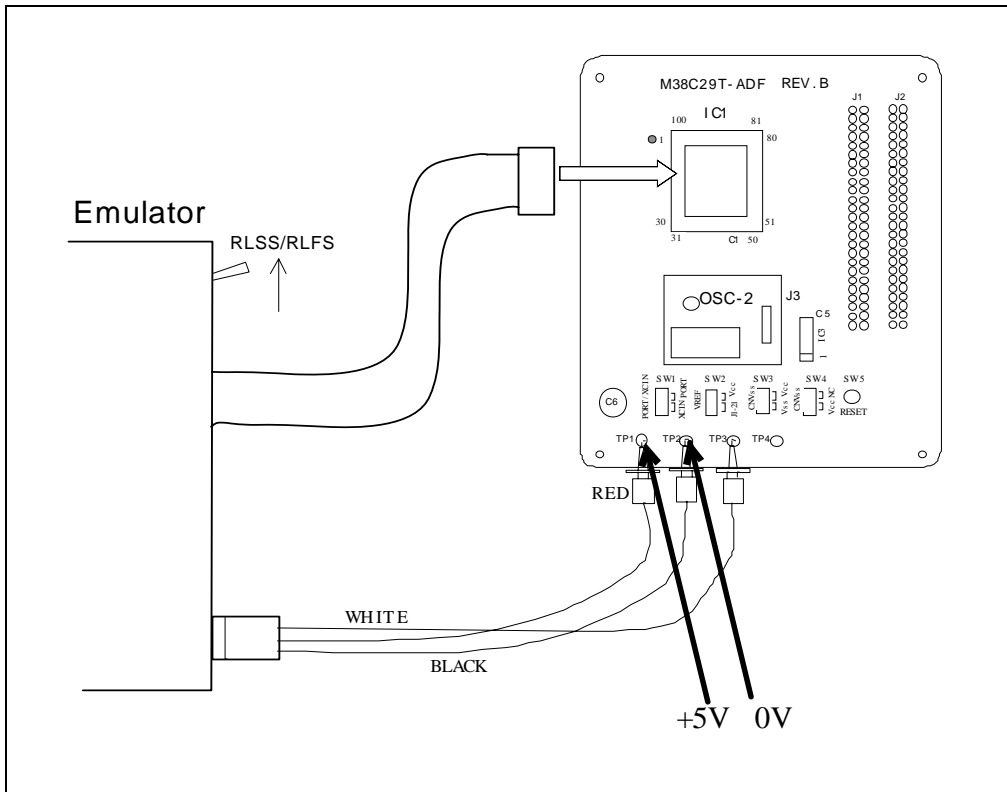

Figure 4.2 Connection pattern of the M38C29T-ADF

(6) Setting SW

Set the SW1 to SW4 according to your application. Table 4.2 describes the functions of the SW1 to SW4.

Table 4.2 Functions of the SW1, SW2, SW3 and SW4 of the M38C29T-ADF

No.	Name	Function	Factory-setting
SW1	PORT/XCIN	Allows you to choose whether to supply the sub-clock signals (32.768kHz) to the MCU's XCIN pin (pin 43). To use P61/XCIN as an output port, choose the PORT side. To use the sub-clock signals, choose the XCIN side.	PORT
SW2	VREF	Allows you to choose whether to apply Vcc or some other source to the MCU's VREF pin (pin 21). In the case of the latter, choose the J1-21 side, and apply a voltage within a prescribed range to the J1-21.	Vcc
SW3	CNVss	Allows you to choose which to connect, Vcc or Vss, to the MCU's CNVss pin (pin 39).	Vss
SW4	XOUT	Allows you to choose whether to pull up the MCU's XOUT pin (pin 46). To use the oscillator circuit of OSC-2 on the temporary target board, or to input the external clock, set SW4 to Vcc to pull up XOUT pin. To use the oscillator circuit with a resonator between XIN and XOUT, set SW4 to NC.	Vcc

5. Oscillator Circuit

5.1 Oscillator Circuit Board

The M38C29T-ADF has a built-in oscillator circuit board on which a 4.0MHz oscillator is mounted.

Figure 5.1 shows an external view of the OSC-2 oscillator circuit board (bare board) and where connector pins are located. Figure 5.2 shows the circuitry of the OSC-2 oscillator circuit board (bare board). Use the number of oscillator circuits recommended by the oscillator manufacturer.

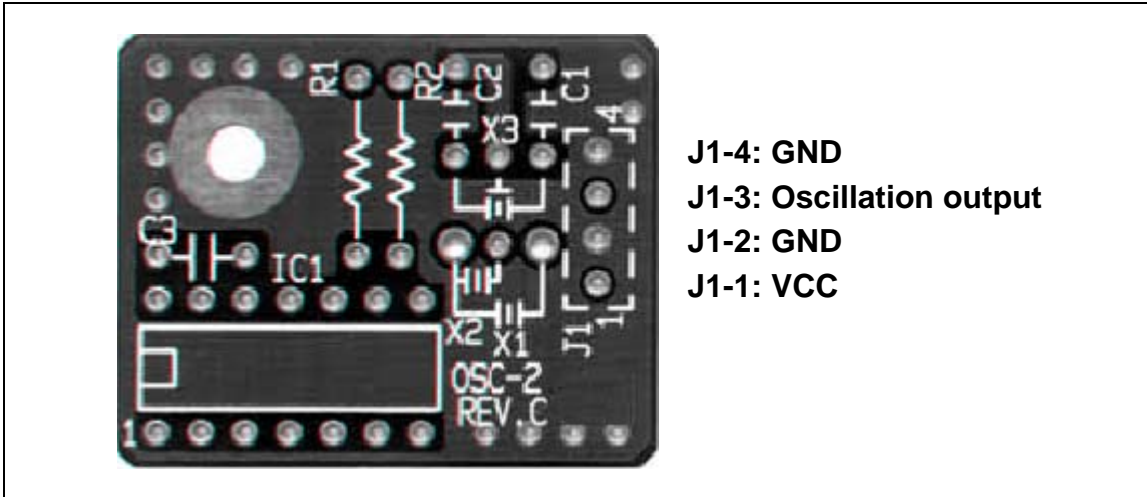

Figure 5.1 External view of the oscillator board (OSC-2) and connector pin assignment

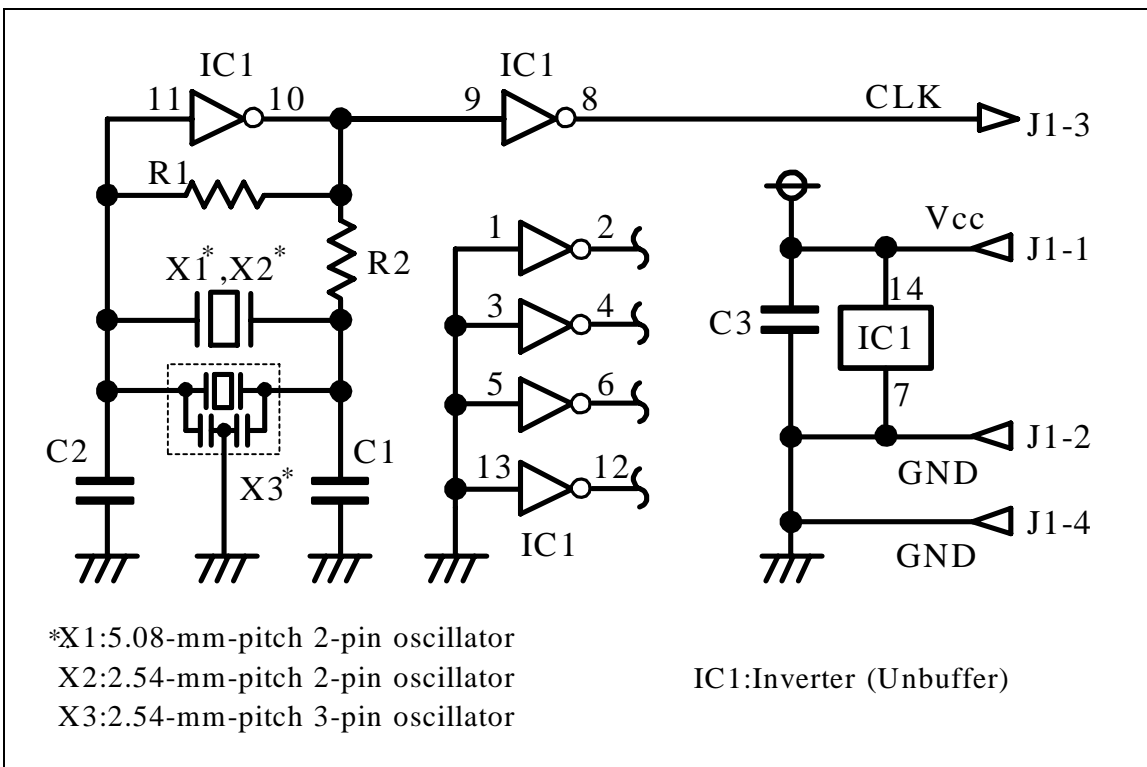

Figure 5.2 Circuit of the oscillator board (OSC-2)

5.2 32.768kHz Oscillator Circuit

The 32.768kHz oscillator circuit is prepared on the M38C29T-ADF. When using the 32.768kHz oscillator circuit as a sub-clock, set SW1 to the XCIN side.

6. Reset Circuit

Figure 6.1 shows the reset circuit and its waveform. In this product, reset is cleared in about 100ms from the instant Vcc passes about 2.1V after having started from 0 V. When Vcc drops down to about 2.1V, reset turns effective.

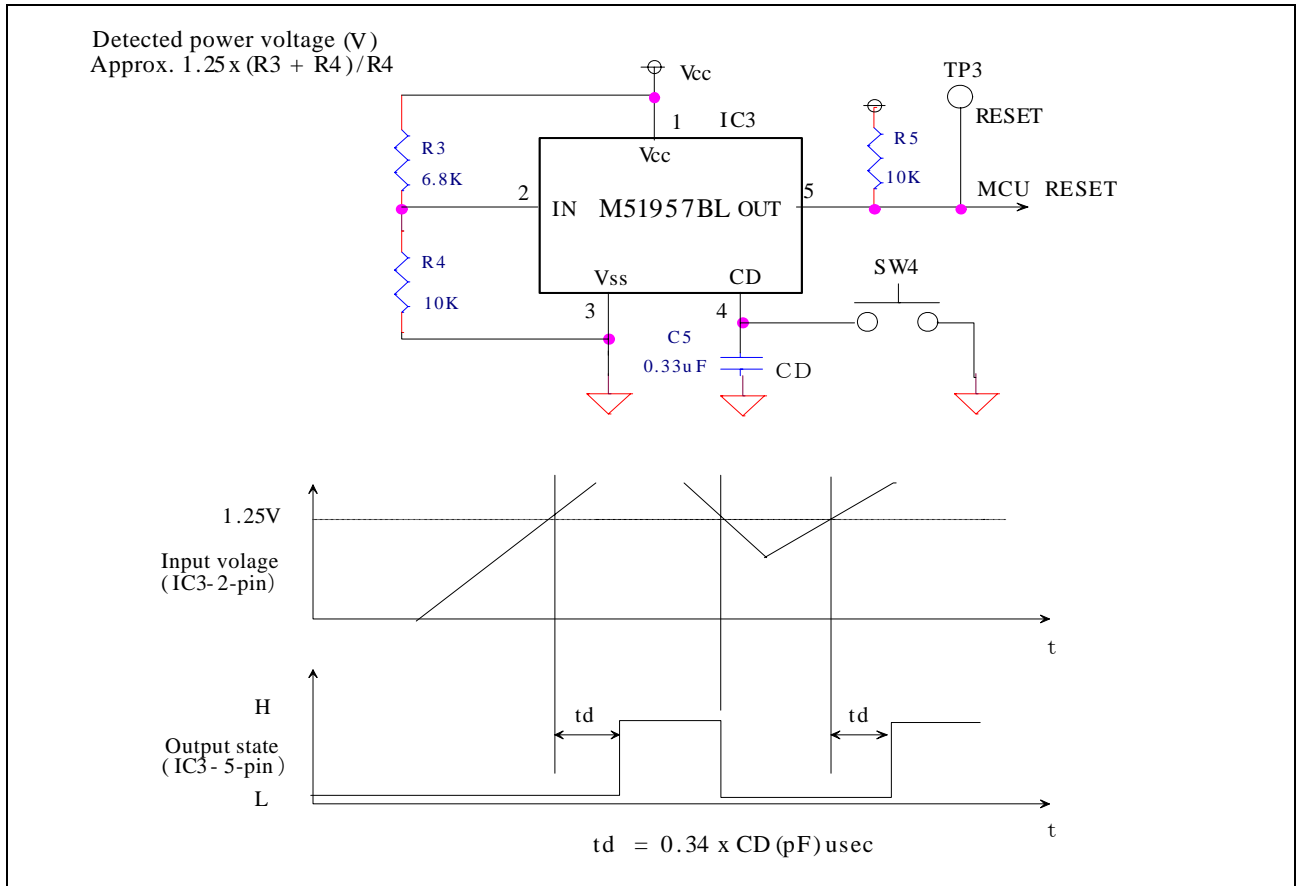

Figure 6.1 Reset circuit and its waveform

By using SW5, the MCU can be reset manually.

Table 6.1 Function of SW5 (reset switch)

No.	Name	Function
SW5	RESET	This is the reset switch. Press down this switch to reset the MCU.

7. Pin Layout

Figure 7.1 shows the pin layout of the M38C29T-ADF.

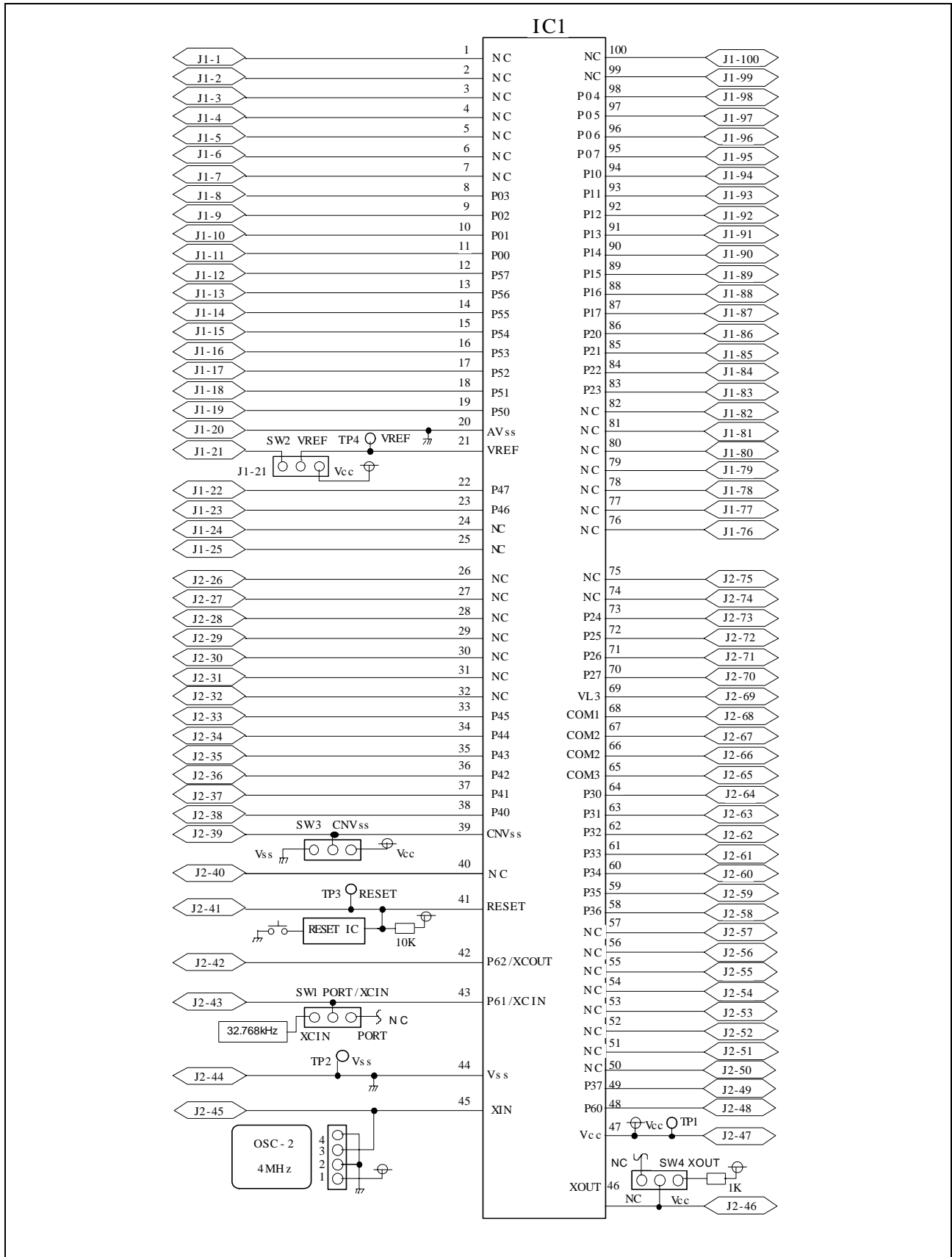

Figure 7.1 Pin layout of the M38C29T-ADF