

M38C29T-64LCA

Converter Board for Connecting 100-pin RFS Type Emulator MCU to 64-pin 0.8-mm-pitch QFP/LQFP
(for 38000 Series 38C1, 38C2, 38K0 and 38K2 Groups)

User's Manual

Notes regarding these materials

1. This document is provided for reference purposes only so that Renesas customers may select the appropriate Renesas products for their use. Renesas neither makes warranties or representations with respect to the accuracy or completeness of the information contained in this document nor grants any license to any intellectual property rights or any other rights of Renesas or any third party with respect to the information in this document.
2. Renesas shall have no liability for damages or infringement of any intellectual property or other rights arising out of the use of any information in this document, including, but not limited to, product data, diagrams, charts, programs, algorithms, and application circuit examples.
3. You should not use the products or the technology described in this document for the purpose of military applications such as the development of weapons of mass destruction or for the purpose of any other military use. When exporting the products or technology described herein, you should follow the applicable export control laws and regulations, and procedures required by such laws and regulations.
4. All information included in this document such as product data, diagrams, charts, programs, algorithms, and application circuit examples, is current as of the date this document is issued. Such information, however, is subject to change without any prior notice. Before purchasing or using any Renesas products listed in this document, please confirm the latest product information with a Renesas sales office. Also, please pay regular and careful attention to additional and different information to be disclosed by Renesas such as that disclosed through our website. (<http://www.renesas.com>)
5. Renesas has used reasonable care in compiling the information included in this document, but Renesas assumes no liability whatsoever for any damages incurred as a result of errors or omissions in the information included in this document.
6. When using or otherwise relying on the information in this document, you should evaluate the information in light of the total system before deciding about the applicability of such information to the intended application. Renesas makes no representations, warranties or guarantees regarding the suitability of its products for any particular application and specifically disclaims any liability arising out of the application and use of the information in this document or Renesas products.
7. With the exception of products specified by Renesas as suitable for automobile applications, Renesas products are not designed, manufactured or tested for applications or otherwise in systems the failure or malfunction of which may cause a direct threat to human life or create a risk of human injury or which require especially high quality and reliability such as safety systems, or equipment or systems for transportation and traffic, healthcare, combustion control, aerospace and aeronautics, nuclear power, or undersea communication transmission. If you are considering the use of our products for such purposes, please contact a Renesas sales office beforehand. Renesas shall have no liability for damages arising out of the uses set forth above.
8. Notwithstanding the preceding paragraph, you should not use Renesas products for the purposes listed below:
 - (1) artificial life support devices or systems
 - (2) surgical implantations
 - (3) healthcare intervention (e.g., excision, administration of medication, etc.)
 - (4) any other purposes that pose a direct threat to human life

Renesas shall have no liability for damages arising out of the uses set forth in the above and purchasers who elect to use Renesas products in any of the foregoing applications shall indemnify and hold harmless Renesas Technology Corp., its affiliated companies and their officers, directors, and employees against any and all damages arising out of such applications.
9. You should use the products described herein within the range specified by Renesas, especially with respect to the maximum rating, operating supply voltage range, movement power voltage range, heat radiation characteristics, installation and other product characteristics. Renesas shall have no liability for malfunctions or damages arising out of the use of Renesas products beyond such specified ranges.
10. Although Renesas endeavors to improve the quality and reliability of its products, IC products have specific characteristics such as the occurrence of failure at a certain rate and malfunctions under certain use conditions. Please be sure to implement safety measures to guard against the possibility of physical injury, and injury or damage caused by fire in the event of the failure of a Renesas product, such as safety design for hardware and software including but not limited to redundancy, fire control and malfunction prevention, appropriate treatment for aging degradation or any other applicable measures. Among others, since the evaluation of microcomputer software alone is very difficult, please evaluate the safety of the final products or system manufactured by you.
11. In case Renesas products listed in this document are detached from the products to which the Renesas products are attached or affixed, the risk of accident such as swallowing by infants and small children is very high. You should implement safety measures so that Renesas products may not be easily detached from your products. Renesas shall have no liability for damages arising out of such detachment.
12. This document may not be reproduced or duplicated, in any form, in whole or in part, without prior written approval from Renesas.
13. Please contact a Renesas sales office if you have any questions regarding the information contained in this document, Renesas semiconductor products, or if you have any other inquiries.



CAUTION

If the requirements shown in the "CAUTION" sentences are ignored, the equipment may cause personal injury or damage to the products.

Renesas Tools Homepage <http://www.renesas.com/tools>

1. Outline

The M38C29T-64LCA is a converter board which connects the 100-pin RFS type emulator MCU (M38C13RLFS, M38C29RLFS, M38K09RFS, M38K29RFS) to a foot pattern for 64-pin 0.8-mm-pitch QFP (PRQP0064GA-A) and 64-pin 0.8-mm-pitch LQFP (PLQP0064GA-A).

2. Package Components

- (1) M38C29T-64LCA x1
 - (2) M38C29T-64LCA User's Manual (This manual) x1
- * When using the M38C29T-64LCA, the following IC socket is required. Purchase it separately.
- 64-pin LCC socket
 - IC61-0644-088: manually soldering type (made by Yamaichi Electronics Co., Ltd.)

3. Specifications

Table 1 Specifications

Applicable package	PRQP0064GA-A (former name:64P6N-A) (64-pin 0.8-mm-pitch QFP)
	PLQP0064GA-A (former name:64P6U-A) (64-pin 0.8-mm-pitch LQFP)

4. Usage

4.1 Oscillator Circuit

The M38C29T-64LCA has two kinds of oscillator circuit patterns for the main clock XIN and the sub clock XCIN.

Depending on the configuration of an oscillator circuit on the user system use them as follows.

- (1) To use the internal oscillator circuit of the MCU
 - Because the converter board exists between the emulator MCU and the user system, the oscillator on the user system may not be able to oscillate. In this case, mount an oscillator circuit on an oscillator circuit pattern (see Figures 2 and 3) of the M38C29T-64LCA. And, to confirm its oscillation, check output waveforms of pins XOUT and XCOU using an oscilloscope.
- (2) To use an oscillator module IC
 - You do not need to mount an oscillator circuit on oscillator circuit pattern of the M38C29T-64LCA.

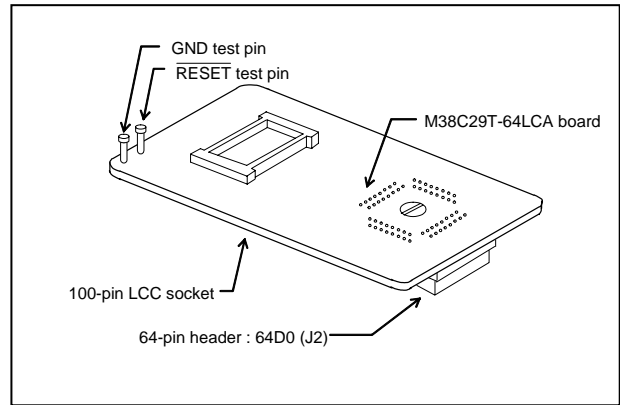

Figure 1 External view of the M38C29T-64LCA

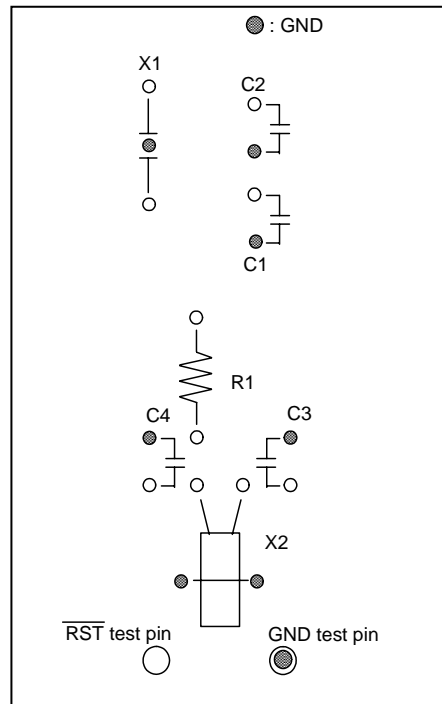

Figure 2 Parts layout of oscillator circuits

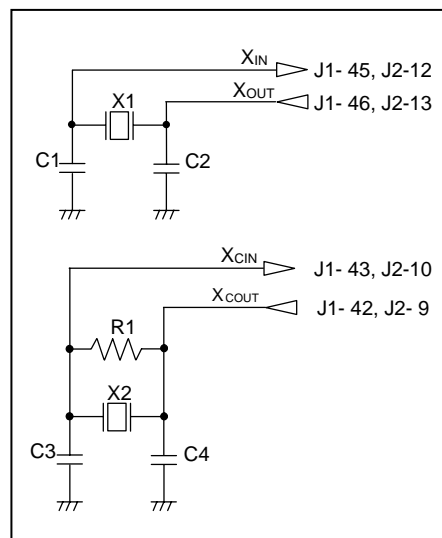

Figure 3 Connection diagrams of the oscillator circuits

4.2 Connecting to User System

Connect the M38C29T-64LCA to the user system as follows.

- (1) Set the head of the screw for releasing the LCC socket at "LOCK" on the board as shown in Figure 4. Turn the screw until it clicks.
- (2) Mount the 64-pin header of the M38C29T-64LCA to the 64-pin LCC socket aligning the polarizing pin.
- (3) The 64-pin header and 64-pin LCC socket are rated at 50 mate/demate cycles.

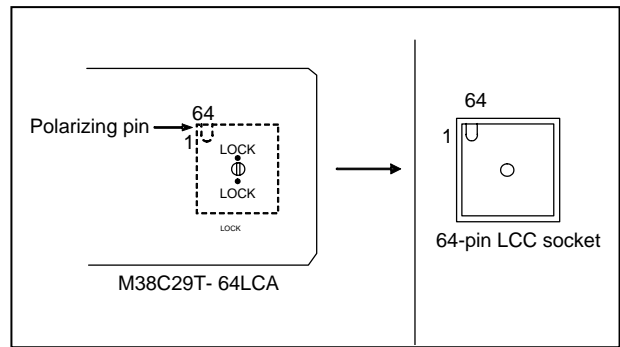

Figure 4 Connecting to the user system

4.3 Removing from User System

Remove the M38C29T-64LCA from the user system as follows.

- (1) Turn the screw for releasing the LCC socket clockwise as shown in Figure 5.
- (2) The M38C29T-64LCA is pushed out from the 64-pin LCC socket.
- (3) After the socket is removed, turn the screw until it clicks.

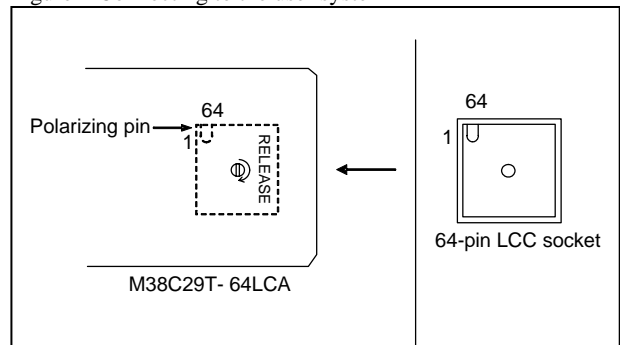

Figure 5 Removing from the user system

5. External Dimensions of the M38C29T-64LCA

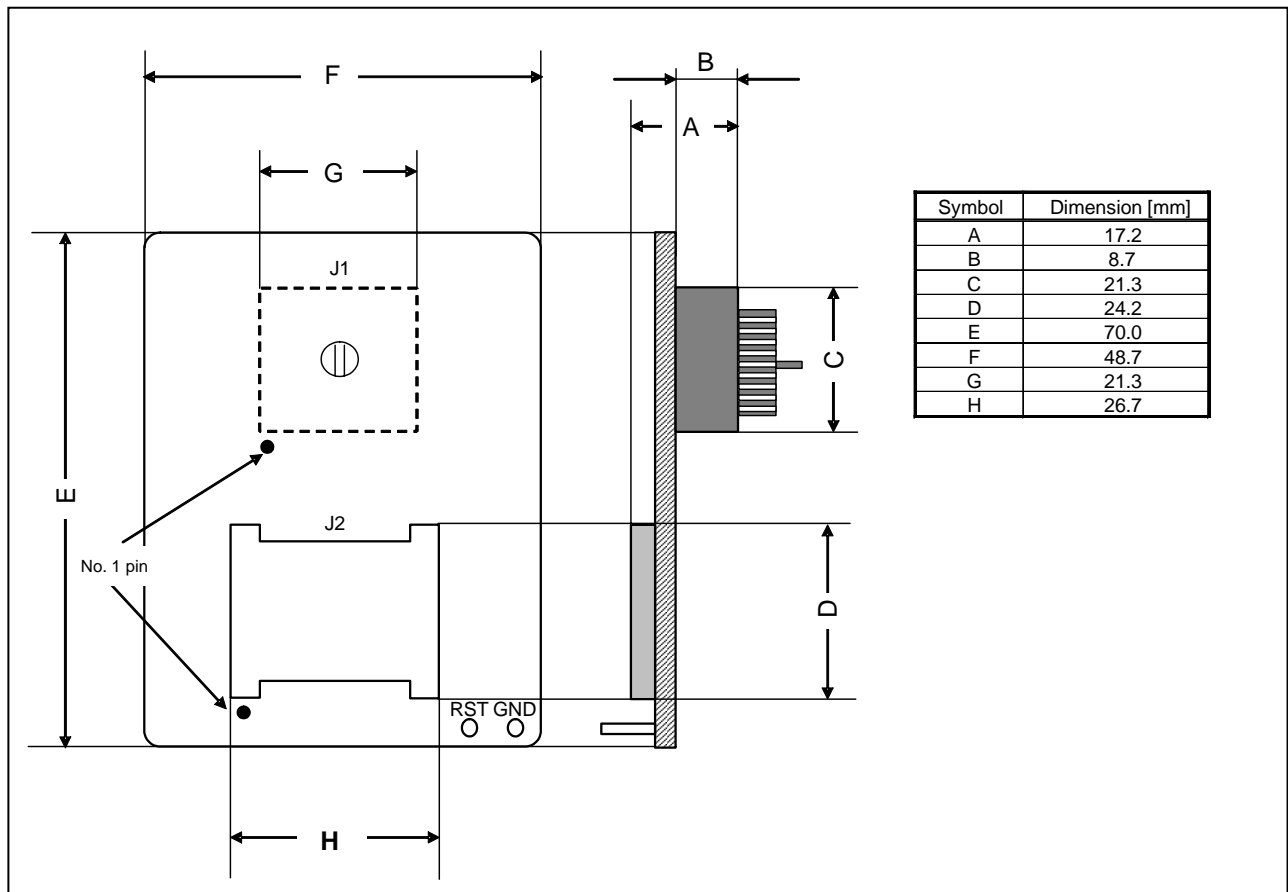

Figure 6 External dimensions of the M38C29T-64LCA

6. Precautions

⚠ CAUTION

Cautions to Be Taken for This Product:



- Before mounting the M38C29T-64LCA, be sure to check the pin positions.

IMPORTANT

Notes on This Product:

- We cannot accept any request for repair.
- For inquiries about the product or the contents of this manual, contact your local distributor.
 Renesas Tools Homepage <http://www.renesas.com/tools>

7. Correspondence of the Connectors

Table 2 Correspondence of connectors J1 and J2

J1 connector Pin No.	J2 connector Pin No.	J1 connector Pin No.	J2 connector Pin No.	J1 connector Pin No.	J2 connector Pin No.	J1 connector Pin No.	J2 connector Pin No.
1	-	26	-	51	-	76	-
2	-	27	-	52	-	77	-
3	-	28	-	53	-	78	-
4	-	29	-	54	-	79	-
5	-	30	-	55	-	80	-
6	-	31	-	56	-	81	-
7	-	32	-	57	-	82	-
8	49	33	1	58	17	83	33
9	50	34	2	59	18	84	34
10	51	35	3	60	19	85	35
11	52	36	4	61	20	86	36
12	53	37	5	62	21	87	37
13	54	38	6	63	22	88	38
14	55	39	7	64	23	89	39
15	56	40	-	65	24	90	40
16	57	41	8	66	25	91	41
17	58	42	9	67	26	92	42
18	59	43	10	68	27	93	43
19	60	44	11	69	28	94	44
20	61	45	12	70	29	95	45
21	62	46	13	71	30	96	46
22	63	47	14	72	31	97	47
23	64	48	15	73	32	98	48
24	-	49	16	74	-	99	-
25	-	50	-	75	-	100	-

("-": No connection)