

M32192T2-PTC

Converter for In-circuit Connection (for M32192FxxFP)

User's Manual

Keep safety first in your circuit designs!

1. Renesas Technology Corporation and Renesas Solutions Corporation put the maximum effort into making semiconductor products better and more reliable, but there is always the possibility that trouble may occur with them. Trouble with semiconductors may lead to personal injury, fire or property damage. Remember to give due consideration to safety when making your circuit designs, with appropriate measures such as (i) placement of substitutive, auxiliary circuits, (ii) use of nonflammable material or (iii) prevention against any malfunction or mishap.

Notes regarding these materials

1. These materials are intended as a reference to assist our customers in the selection of the Renesas Technology product best suited to the customer's application; they do not convey any license under any intellectual property rights, or any other rights, belonging to Renesas Technology Corporation, Renesas Solutions Corporation or a third party.
2. Renesas Technology Corporation and Renesas Solutions Corporation assume no responsibility for any damage, or infringement of any third-party's rights, originating in the use of any product data, diagrams, charts, programs, algorithms, or circuit application examples contained in these materials.
3. All information contained in these materials, including product data, diagrams, charts, programs and algorithms represents information on products at the time of publication of these materials, and are subject to change by Renesas Technology Corporation and Renesas Solutions Corporation without notice due to product improvements or other reasons. It is therefore recommended that customers contact Renesas Technology Corporation, Renesas Solutions Corporation or an authorized Renesas Technology product distributor for the latest product information before purchasing a product listed herein. The information described here may contain technical inaccuracies or typographical errors. Renesas Technology Corporation and Renesas Solutions Corporation assume no responsibility for any damage, liability, or other loss rising from these inaccuracies or errors. Please also pay attention to information published by Renesas Technology Corporation and Renesas Solutions Corporation by various means, including the Renesas home page (<http://www.renesas.com>).
4. When using any or all of the information contained in these materials, including product data, diagrams, charts, programs, and algorithms, please be sure to evaluate all information as a total system before making a final decision on the applicability of the information and products. Renesas Technology Corporation and Renesas Solutions Corporation assume no responsibility for any damage, liability or other loss resulting from the information contained herein.
5. Renesas Technology semiconductors are not designed or manufactured for use in a device or system that is used under circumstances in which human life is potentially at stake. Please contact Renesas Technology Corporation, Renesas Solutions Corporation or an authorized Renesas Technology product distributor when considering the use of a product contained herein for any specific purposes, such as apparatus or systems for transportation, vehicular, medical, aerospace, nuclear, or undersea repeater use.
6. The prior written approval of Renesas Technology Corporation and Renesas Solutions Corporation is necessary to reprint or reproduce in whole or in part these materials.
7. If these products or technologies are subject to the Japanese export control restrictions, they must be exported under a license from the Japanese government and cannot be imported into a country other than the approved destination. Any diversion or reexport contrary to the export control laws and regulations of Japan and/or the country of destination is prohibited.
8. Please contact Renesas Technology Corporation or Renesas Solutions Corporation for further details on these materials or the products contained therein.

Precautions to be taken when using this product

1. This product is a development supporting unit for use in your program development and evaluation stages. In mass-producing your program you have finished developing, be sure to make a judgment on your own risk that it can be put to practical use by performing integration test, evaluation, or some experiment else.
2. In no event shall Renesas Solutions Corporation be liable for any consequence arising from the use of this product.
3. Renesas Solutions Corporation strives to renovate or provide a workaround for product malfunction at some charge or without charge. However, this does not necessarily mean that Renesas Solutions Corporation guarantees the renovation or the provision under any circumstances.
4. This product has been developed by assuming its use for program development and evaluation in laboratories. Therefore, it does not fall under the application of Electrical Appliance and Material Safety Law and protection against electromagnetic interference when used in Japan.



CAUTION

If the requirements shown in the "CAUTION" sentences are ignored, the equipment may cause personal injury or damage to the products.

Renesas Tools Homepage <http://www.renesas.com/tools>

1. Outline

The M32192T2-PTC is a converter board for featuring the debugging function such as real-time tracing when using the SDI emulator, M32100T-SDI-E, M32170T-SDI, M32100T2-SDI-E, M32100T3-SDI-E or M32100T5-SDI-E with the M32192FxxFP.

Compared with the M32100T3-SDI-E or M32100T5-SDI-E, more loss of trace information occurs when using with the M32100T-SDI-E, M32170T-SDI or M32100T2-SDI-E.

For M32192T2-PTC, using with the M32100T3-SDI-E or M32100T5-SDI-E is recommended.

2. Package Components

- (1) M32192T2-PTC converter board
- (2) YQPACK144SD (made by Tokyo Electech Corporation)
- (3) NQPACK144SD (made by Tokyo Electech Corporation)
- (4) YQ-GUIDE x 4 (made by Tokyo Electech Corporation)
- (5) Screwdriver (made by Tokyo Electech Corporation)
- (6) M32192T2-PTC User's Manual (This manual)
- (7) M32192T2-PTC User's Manual (Japanese)

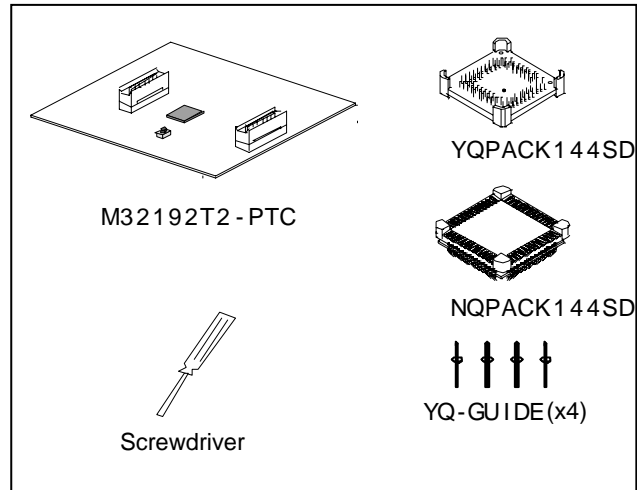

Figure 2.1 Package components

Table 3.1 Specifications

Applicable package	PLQP0144KA-A, 144P6Q-A (144-pin 0.5mm pitch LQFP)
Applicable MCU	M32192FxxFP
Supported emulator	M32100T-SDI-E, M32170T-SDI, M32100T2-SDI-E, M32100T3-SDI-E or M32100T5-SDI-E With the M32100T-SDI-E, M32170T-SDI, separately available M3T-PTC-CNV is required.
Mounted MCU	M32192F8VWG
Clock	20MHz
MCU power supply	Supplied from the user system

4. Usage

The M32192T2-PTC can be used for debugging and on-board evaluation in common by mounting the NQPACK144SD on the user system.

- (1) For debugging
Mount the NQPACK144SD (included with the M32192T2-PTC) on the 144-pin QFP foot pattern of the user system. Then connect the M32192T2-PTC via YQPACK144SD. As the M32192F8VWG is mounted on the M32192T2-PTC, all functions of the emulator such as real-time tracing can be used.
Before using the M32192T2-PTC, be sure to read "8. Precautions" on page 6.
- (2) For on-board evaluation
Mount the M32192FxxFP and the HQPACK144SD (separately available) in that order on the NQPACK144SD on the user system.

5. Connection Procedure

5.1 For the M32100T-SDI-E, or M32170T-SDI.

- (1) Mount the NQPACK144SD on the user system
- (2) Connect the YQPACK144SD on the NQPACK144SD.
- (3) Secure the four corners of the YQPACK144SD with the YQ-GUIDE's.
- (4) Mount the M32192T2-PTC on the YQPACK144SD.
- (5) Set the clock select switch.
- (6) Mount the M3T-PTC-CNV on the M32192T2-PTC.
- (7) Connect the emulation pod probe to the M32192T2-PTC via the SDI MCU control interface cable and the SDI trace interface cable.

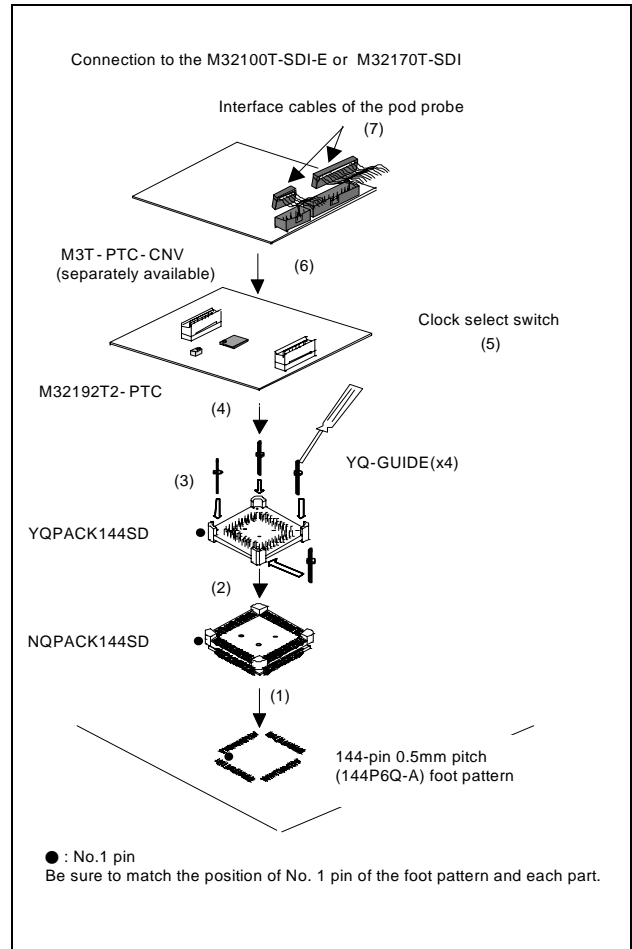

Figure 5.1 Connection Procedure(1)

5.2 For the M32100T2-SDI-E, M32100T3-SDI-E or M32100T5-SDI-E.

- (1) Mount the NQPACK144SD on the user system
- (2) Connect the YQPACK144SD on the NQPACK144SD.
- (3) Secure the four corners of the YQPACK144SD with the YQ-GUIDE's.
- (4) Mount the M32192T2-PTC on the YQPACK144SD.
- (5) Set the clock select switch.
- (6) Connect the emulator probe to the M32192T2-PTC.

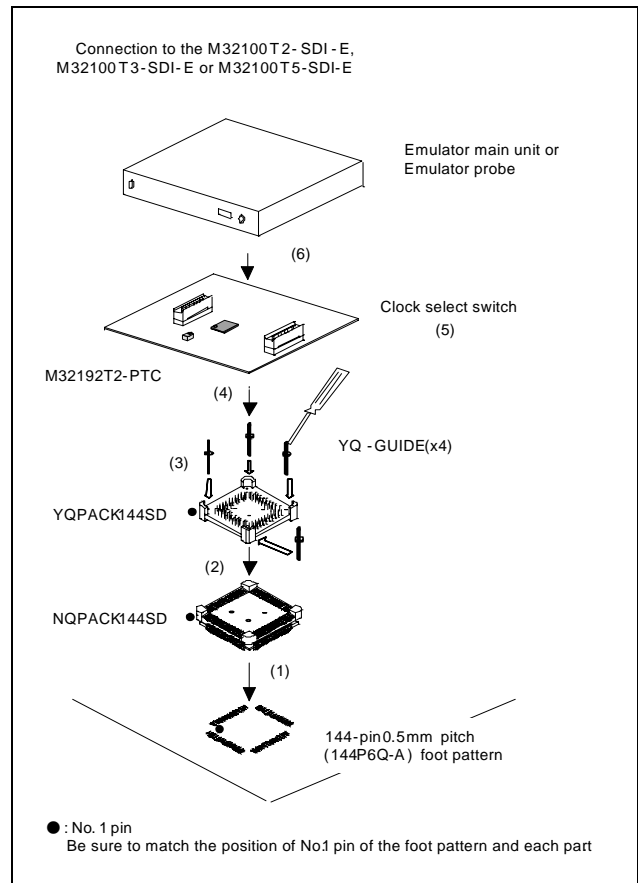

Figure 5.2 Connection Procedure(2)

5.3 On-board Evaluation.

- (1) Mount the NQPACK144SD on the user system
- (2) Mount the M32192FxxFP on the NQPACK144SD.
- (3) Mount the HQPACK144SD on the NQPACK144SD.

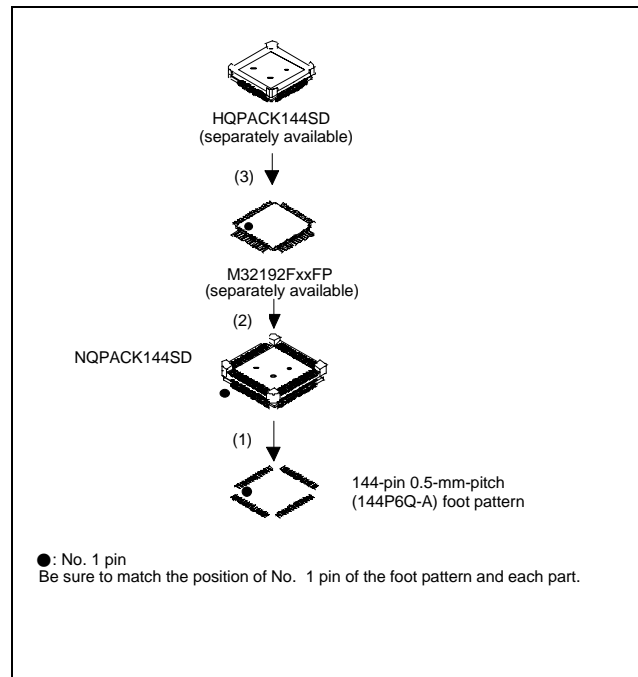

Figure 5.3 Connection Procedure(3)

6. Selecting a Clock

With the M32192T2-PTC, it is possible to select a clock supply to the MCU by the clock select switch (SW1). Select a clock supply as shown below.

However, when used with the M32192T2-PTC, the clock cannot be supplied from the user system.

(1) 20 MHz:

Supplies the clock (X1: 20 MHz) on the M32192T2-PTC board to the MCU.

(2) SOCKET:

Supplies the clock to the MCU from the socket (X2) for mounting an oscillator on the M32192T2-PTC board. By mounting an oscillator to the X2 socket of the MCU, it is possible to change the operating frequency.

Figure 6.1 shows the connecting the X2 socket and the MCU.

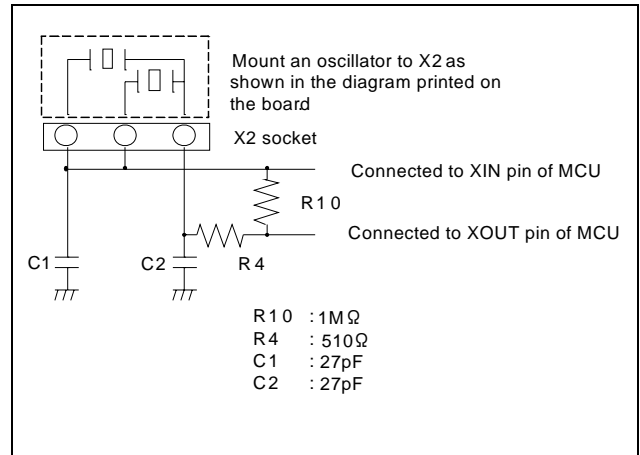

Figure 6.1 Connection diagram of X2 socket

7. External Dimensions and a Sample Foot Pattern of the M32192T2-PTC

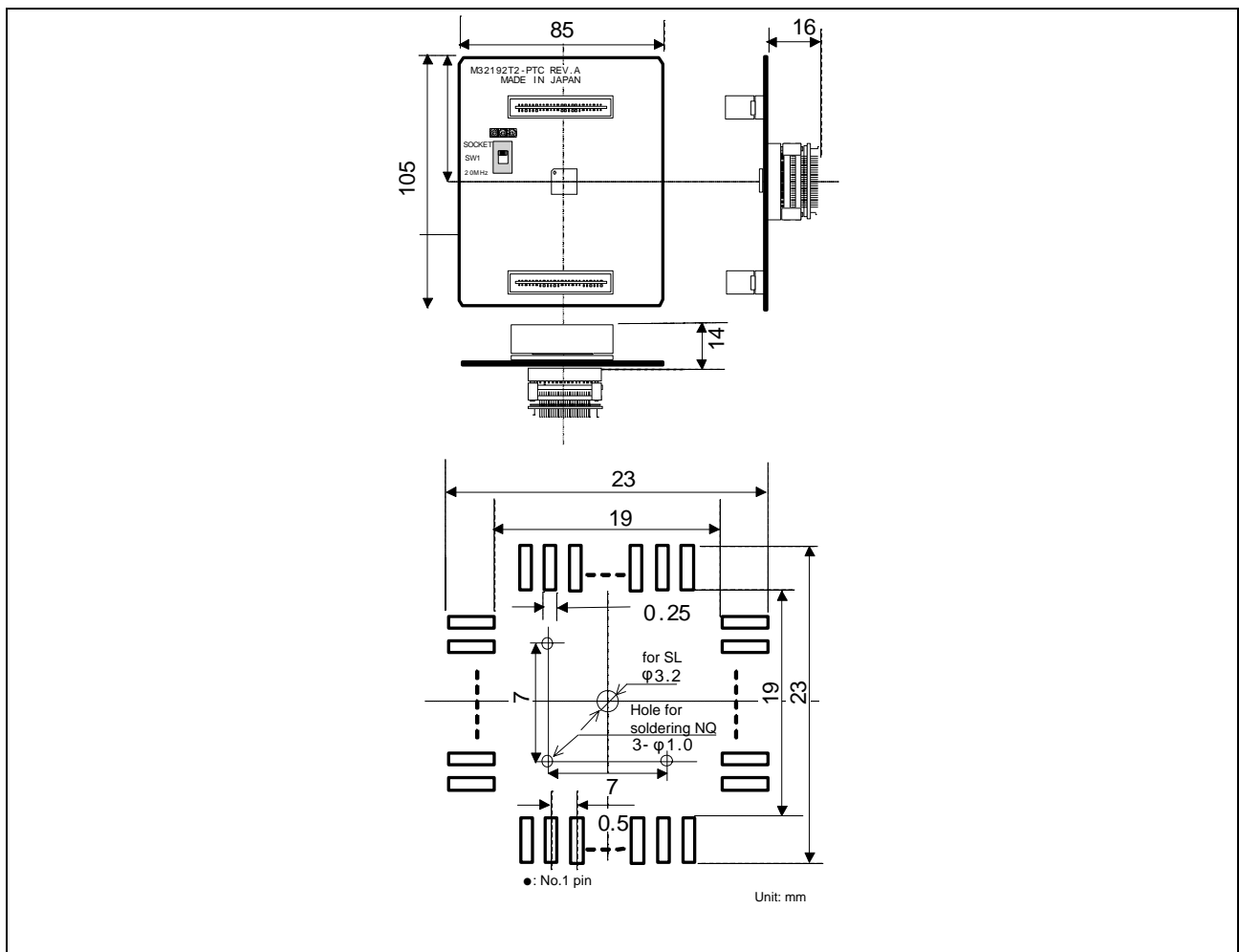

Figure 7.1 External dimensions and a sample foot pattern of the M32192T2-PTC

8. Precautions

CAUTION

Cautions to Be Taken for Emulator:



- For debugging, use this product in the combination with the SDI emulator, M32100-SDI-E, M32170T-SDI, M32100T2-SDI-E, M32100T3-SDI-E or M32100T5-SDI-E.
- When using with the M32100T-SDI-E or M32170T-SDI, the following restrictions are applied according to the MCU operating frequency. The M32192T2-PTC is recommended to use with the M32100T3-SDI-E or M32100T5-SDI-E.
 - More than 66 MHz:
Compared with the M32100T2-SDI-E, M32100T3-SDI-E, or M32100T5-SDI-E, more loss of trace information occurs.
 - 66 MHz or less:
Same as the M32100T2-SDI-E, M32100T3-SDI-E or M32100T5-SDI-E.
- When using with the M32100T-SDI-E or M32170T-SDI, separately available M3T-PTC-CNV is required.
- When connecting to the M32100T-SDI-E or M32170T-SDI, connect the both cables for connecting the emulator, the SDI MCU control interface cable (10-pin) and the SDI trace interface cable (20-pin).
- For the precautions for the combination of the emulator, refer to the user's manual of each emulator.

Cautions for Differences between MCUs and This Product:

- For debugging, as the M32192F8VWG (1MB internal Flash ROM) on the M32192T2-PTC is used, be careful about the difference of the internal ROM size.
- When the clock select switch is set to the "SOCKET" side, the oscillation occurs by itself, be careful about the difference of the resistance and the capacitor.
- The capacitive load of the all lines of the MCU will increase depending on wirings and connectors. Use the part whose timing is critical after checking it works properly.

Cautions to Be Taken for This Product:

- When connecting the YQPACK144SD, be sure to use the included YQ-GUIDE's.
- We cannot accept any request for repair.
- For purchasing the NQPACK144SD, YQPACK144SD and HQPACK144SD contact the following:
Tokyo Eletech Corporation http://www.tetc.co.jp/e_index.htm
- For inquiries about the product or the contents of this manual, contact your local distributor.
Renesas Tools Homepage <http://www.renesas.com/tools>