

M38C29T-64FPD

Converter Board for Connecting 100-pin RFS Type Emulator MCU to 64-pin 0.5-mm-pitch LQFP
(for 38000 Series 38C1, 38C2, 38K0 and 38K2 Groups)

User's Manual

Keep safety first in your circuit designs!

- Renesas Technology Corporation and Renesas Solutions Corporation put the maximum effort into making semiconductor products better and more reliable, but there is always the possibility that trouble may occur with them. Trouble with semiconductors may lead to personal injury, fire or property damage. Remember to give due consideration to safety when making your circuit designs, with appropriate measures such as (i) placement of substitutive, auxiliary circuits, (ii) use of nonflammable material or (iii) prevention against any malfunction or mishap.

Notes regarding these materials

- These materials are intended as a reference to assist our customers in the selection of the Renesas Technology product best suited to the customer's application; they do not convey any license under any intellectual property rights, or any other rights, belonging to Renesas Technology Corporation, Renesas Solutions Corporation or a third party.
- Renesas Technology Corporation and Renesas Solutions Corporation assume no responsibility for any damage, or infringement of any third-party's rights, originating in the use of any product data, diagrams, charts, programs, algorithms, or circuit application examples contained in these materials.
- All information contained in these materials, including product data, diagrams, charts, programs and algorithms represents information on products at the time of publication of these materials, and are subject to change by Renesas Technology Corporation and Renesas Solutions Corporation without notice due to product improvements or other reasons. It is therefore recommended that customers contact Renesas Technology Corporation, Renesas Solutions Corporation or an authorized Renesas Technology product distributor for the latest product information before purchasing a product listed herein. The information described here may contain technical inaccuracies or typographical errors. Renesas Technology Corporation and Renesas Solutions Corporation assume no responsibility for any damage, liability, or other loss rising from these inaccuracies or errors. Please also pay attention to information published by Renesas Technology Corporation and Renesas Solutions Corporation by various means, including the Renesas home page (<http://www.renesas.com>).
- When using any or all of the information contained in these materials, including product data, diagrams, charts, programs, and algorithms, please be sure to evaluate all information as a total system before making a final decision on the applicability of the information and products. Renesas Technology Corporation and Renesas Solutions Corporation assume no responsibility for any damage, liability or other loss resulting from the information contained herein.
- Renesas Technology semiconductors are not designed or manufactured for use in a device or system that is used under circumstances in which human life is potentially at stake. Please contact Renesas Technology Corporation, Renesas Solutions Corporation or an authorized Renesas Technology product distributor when considering the use of a product contained herein for any specific purposes, such as apparatus or systems for transportation, vehicular, medical, aerospace, nuclear, or undersea repeater use.
- The prior written approval of Renesas Technology Corporation and Renesas Solutions Corporation is necessary to reprint or reproduce in whole or in part these materials.
- If these products or technologies are subject to the Japanese export control restrictions, they must be exported under a license from the Japanese government and cannot be imported into a country other than the approved destination. Any diversion or reexport contrary to the export control laws and regulations of Japan and/or the country of destination is prohibited.
- Please contact Renesas Technology Corporation or Renesas Solutions Corporation for further details on these materials or the products contained therein.

Precautions to be taken when using this product

- This product is a development supporting unit for use in your program development and evaluation stages. In mass-producing your program you have finished developing, be sure to make a judgment on your own risk that it can be put to practical use by performing integration test, evaluation, or some experiment else.
- In no event shall Renesas Solutions Corporation be liable for any consequence arising from the use of this product.
- Renesas Solutions Corporation strives to renovate or provide a workaround for product malfunction at some charge or without charge. However, this does not necessarily mean that Renesas Solutions Corporation guarantees the renovation or the provision under any circumstances.
- This product has been developed by assuming its use for program development and evaluation in laboratories. Therefore, it does not fall under the application of Electrical Appliance and Material Safety Law and protection against electromagnetic interference when used in Japan.



CAUTION

If the requirements shown in the "CAUTION" sentences are ignored, the equipment may cause personal injury or damage to the products.

Renesas Tools Homepage <http://www.renesas.com/en/tools>

Rev. 1.00

June 1, 2003

REJ10J0149-0100Z

Renesas Technology

www.renesas.com

1. Outline

The M38C29T-64FPD is a converter board which connects the 100-pin RFS type emulator MCU (M38C13RLFS, M38C29RLFS, M38K09RFS, M38K29RFS) to a foot pattern for 64-pin 0.5-mm-pitch LQFP (64P6Q-A).

2. Package Components

- (1) M38C29T-64FPD x1
- (2) TQSOCKET064SDG x1
- (3) TQPACK064SD x1
- (4) M38C29T-64FPD User's Manual (This manual) x1

* When using the M38C29T-64FPD, mount the included IC socket.

64-pin QFP socket TQPACK064SD
(made by Tokyo Eletech Corporation)

3. Specifications

Table 1 Specifications

Applicable package	64P6Q-A (64-pin 0.5-mm-pitch LQFP)
Insertion/removal iterations of connector	100 times or less guaranteed

4. Usage

4.1 Oscillator Circuit

The M38C29T-64FPD has two kinds of oscillator circuit patterns for the main clock XIN and the sub clock XCIN.

Depending on the configuration of an oscillator circuit on the target system use them as follows.

- (1) To use the internal oscillator circuit of the MCU
Because the converter board exists between the emulator MCU and the target system, the oscillator on the target board may not be able to oscillate. In this case, mount an oscillator circuit on an oscillator circuit pattern (see Figures 2 and 3) of the M38C29T-64FPD. And, to confirm its oscillation, check output waveforms of pins XOUT and XCOU using an oscilloscope.
- (2) To use an oscillator module IC
You do not need to mount an oscillator circuit on oscillator circuit pattern of the M38C29T-64FPD.

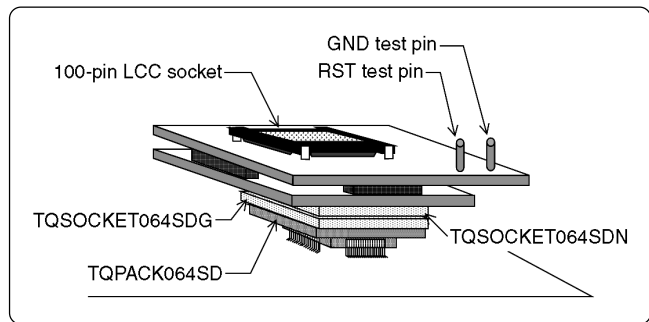

Figure 1 External view of the M38C29T-64FPD

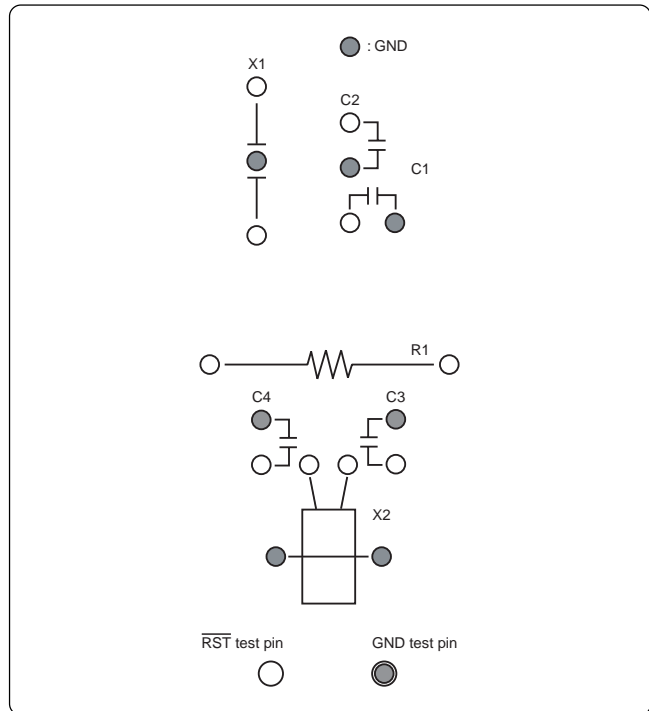

Figure 2 Parts layout of oscillator circuits

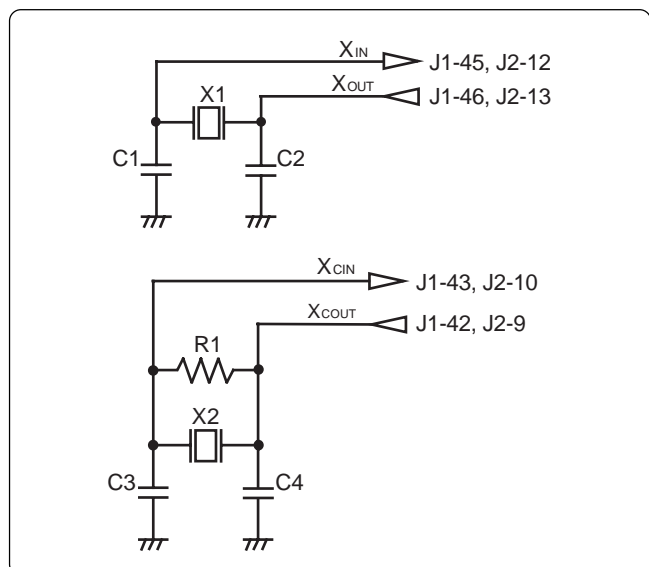

Figure 3 Connection diagrams of the oscillator circuits

4.2 Connecting to Target System

Connect the M38C29T-64FPD to the target system as follows.

- (1) Mount the TQPACK064SD on the target system.
- (2) Attach the TQSOCKET064SDG to the TQPACK064SD.
- (3) Attach the J2 (TQSOCKET064SDN) of the M38C29T-64FPD to the TQSOCKET064SDG.

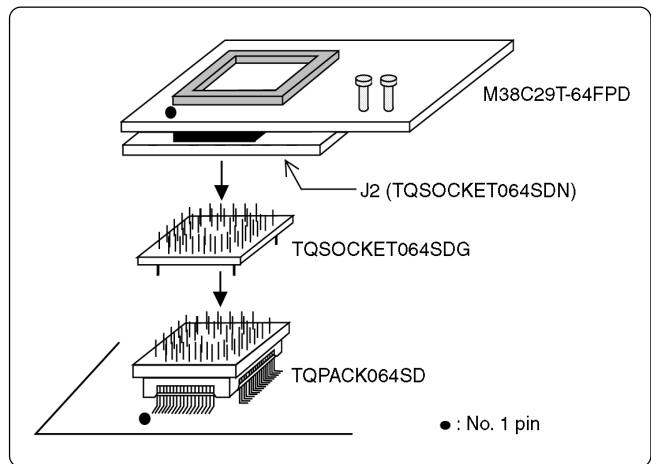

Figure 4 Connecting to the target system

5. External Dimensions of the M38C29T-64FPD

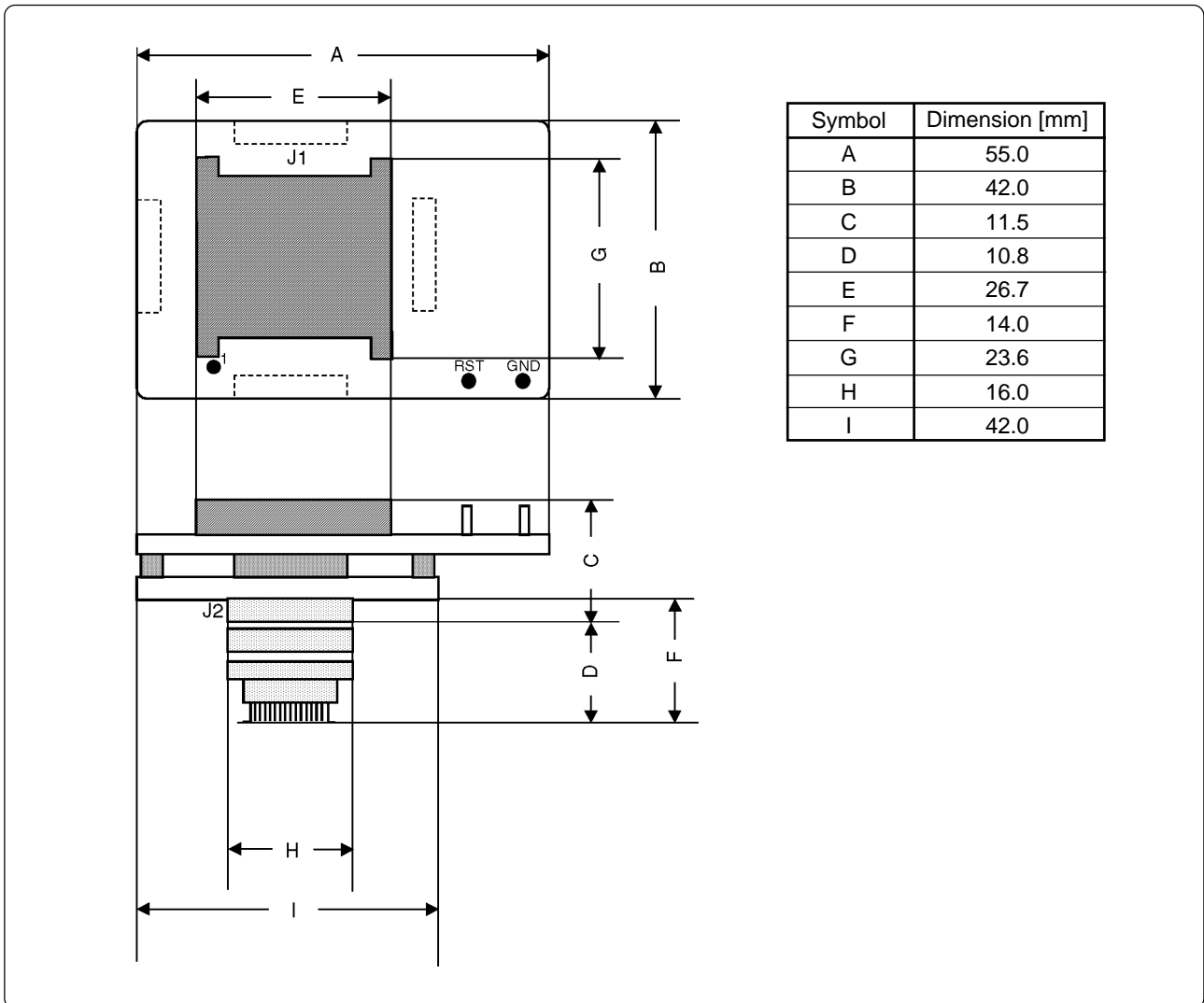

Figure 5 External dimensions of the M38C29T-64FPD

6. Precautions

CAUTION

Cautions to Be Taken for This Product:



- Before mounting the M38C29T-64FPD, be sure to check the pin positions.

IMPORTANT

Notes on This Product:

- We cannot accept any request for repair.
- To purchase the TQPACK064SD and TQSOCKET064SDG for replacement, contact the following.
Tokyo Eletech Corporation
http://www.tetc.co.jp/e_tet.htm
- For inquiries about this product or the contents of this manual, contact your local distributor.
Renesas Tools Homepage <http://www.renesas.com/en/tools>

7. Correspondence of the Connectors

Table 2 Correspondence of connectors J1 and J2

J1 connector Pin No.	J2 connector Pin No.	J1 connector Pin No.	J2 connector Pin No.	J1 connector Pin No.	J2 connector Pin No.	J1 connector Pin No.	J2 connector Pin No.
1	-	26	-	51	-	76	-
2	-	27	-	52	-	77	-
3	-	28	-	53	-	78	-
4	-	29	-	54	-	79	-
5	-	30	-	55	-	80	-
6	-	31	-	56	-	81	-
7	-	32	-	57	-	82	-
8	49	33	1	58	17	83	33
9	50	34	2	59	18	84	34
10	51	35	3	60	19	85	35
11	52	36	4	61	20	86	36
12	53	37	5	62	21	87	37
13	54	38	6	63	22	88	38
14	55	39	7	64	23	89	39
15	56	40	-	65	24	90	40
16	57	41	8	66	25	91	41
17	58	42	9	67	26	92	42
18	59	43	10	68	27	93	43
19	60	44	11	69	28	94	44
20	61	45	12	70	29	95	45
21	62	46	13	71	30	96	46
22	63	47	14	72	31	97	47
23	64	48	15	73	32	98	48
24	-	49	16	74	-	99	-
25	-	50	-	75	-	100	-

("-": No connection)