

## USER GUIDE AND SPECIFICATIONS

# NI USB-9215 Series

## 4-Channel, $\pm 10$ VDC, 16-Bit Simultaneous Sampling Analog Input Devices

このドキュメントの日本語版については、[ni.com/manuals](http://ni.com/manuals)を参照してください。(For a Japanese language version, go to [ni.com/manuals](http://ni.com/manuals).)

This user guide describes how to use the National Instruments USB-9215 Series and lists the specifications. In this document, the NI USB-9215/9215A with screw terminal or backshell and NI USB-9215A with BNC are referred to inclusively as the NI USB-9215 Series.

## Introduction

The NI USB-9215 Series data acquisition devices provide a USB interface for four channels of 16-bit simultaneous sampling analog inputs with integrated signal conditioning. The NI USB-9215 Series consists of two components: an NI 9215 module and an NI USB-9161/9162 USB carrier, as shown in Figure 1.

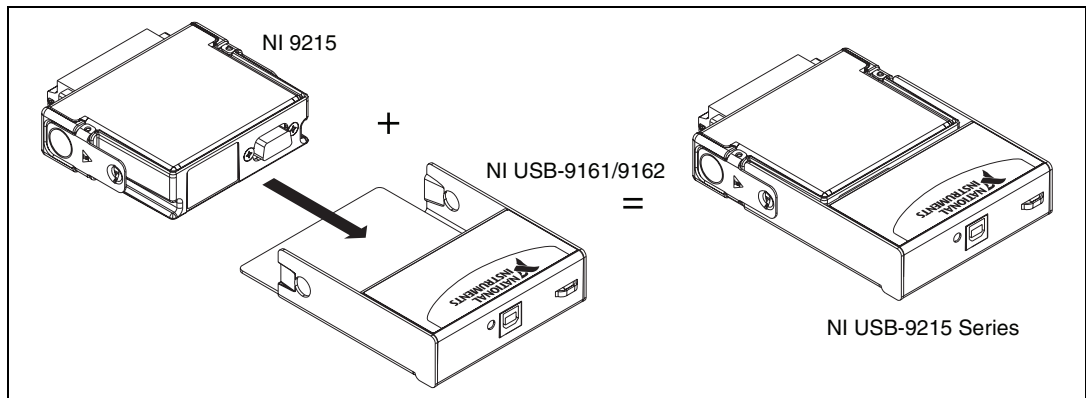
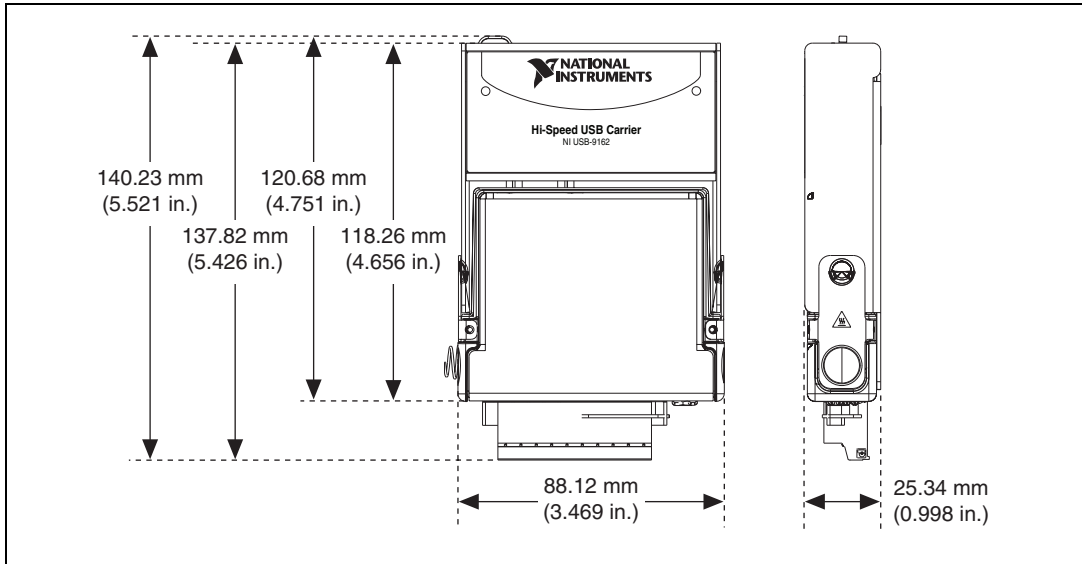

Figure 1. NI USB-9215 Series Components

# Dimensions

Figures 2 and 3 show the NI USB-9215 Series device dimensions.



**Figure 2.** NI USB-9215 (Screw Terminal) in Millimeters (Inches)

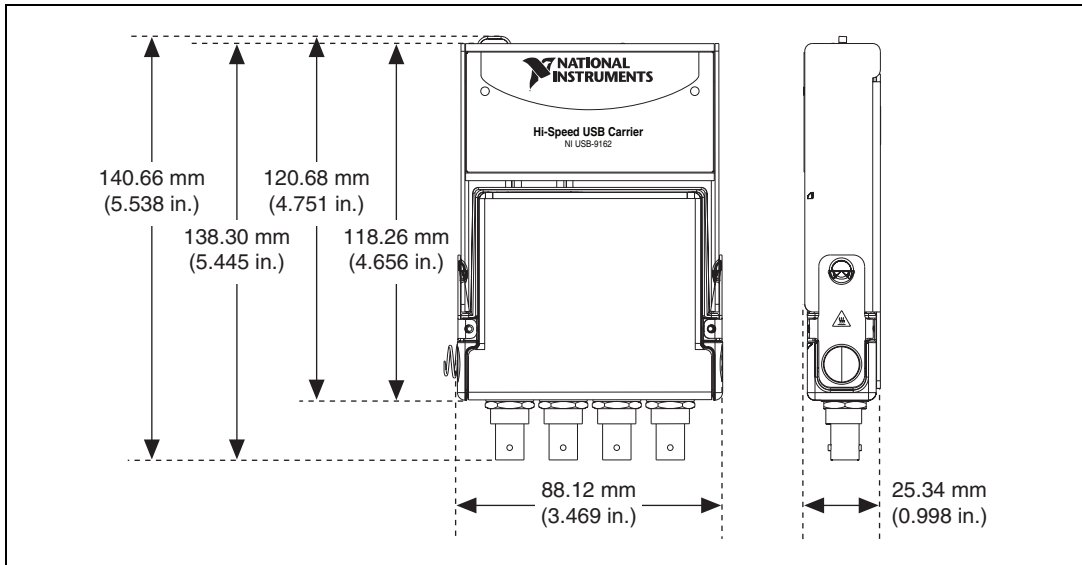

**Figure 3.** NI USB-9215 (BNC) in Millimeters (Inches)

# Safety Guidelines

---

Operate the NI USB-9215 Series only as described in these operating instructions.



**Note** Although the NI 9215 module may have more stringent certification standards than the NI USB-9215 Series, when used with the NI USB-9161/9162 carrier, the combined system may be limited. Refer to the [Specifications](#) section of this document for more details.



**Hot Surface** This icon denotes that the component may be hot. Touching this component may result in bodily injury.



**Caution** Do *not* disconnect I/O-side wires or connectors unless power has been switched off or the area is known to be nonhazardous.



**Caution** Do *not* remove modules unless power has been switched off or the area is known to be nonhazardous.



**Caution** The NI USB-9215 Series is not certified for use in hazardous locations.

## Safety Guidelines for Hazardous Voltages

If *hazardous voltages* are connected to the module, take the following precautions. A hazardous voltage is a voltage greater than 42.4 V<sub>pk</sub> or 60 VDC to earth ground.



**Caution** Ensure that hazardous voltage wiring is performed only by qualified personnel adhering to local electrical standards.



**Caution** Do *not* mix hazardous voltage circuits and human-accessible circuits on the same module.



**Caution** Make sure that devices and circuits connected to the module are properly insulated from human contact.



**Caution** When module terminals are live with hazardous voltages, make sure the terminals are not accessible by using the high voltage screw terminal backshell. Refer to the [Assembling the High Voltage Screw Terminal Backshell](#) section for more information.

# Related Documentation

---

Each application software package and driver includes information about writing applications for taking measurements and controlling measurement devices. The following references to documents assume you have NI-DAQmx 8.7 or later, NI-DAQmx Base version 3.x, and where applicable, version 7.1 or later of the NI application software.

## NI-DAQmx for Windows

The *DAQ Getting Started Guide* describes how to install your NI-DAQmx for Windows software, how to install your NI-DAQmx-supported DAQ device, and how to confirm that your device is operating properly. Select **Start»All Programs»National Instruments»NI-DAQ»DAQ Getting Started Guide**.

The *NI-DAQ Readme* lists which devices are supported by this version of NI-DAQ. Select **Start»All Programs»National Instruments»NI-DAQ»NI-DAQ Readme**.

The *NI-DAQmx Help* contains general information about measurement concepts, key NI-DAQmx concepts, and common applications that are applicable to all programming environments. Select **Start»All Programs»National Instruments»NI-DAQ»NI-DAQmx Help**.



**Note** For information about non-Windows operating system support, refer to [ni.com/info](http://ni.com/info) and enter BaseGSGML.

## LabVIEW

If you are a new user, use the *Getting Started with LabVIEW* manual to familiarize yourself with the LabVIEW graphical programming environment and the basic LabVIEW features you use to build data acquisition and instrument control applications. Open the *Getting Started with LabVIEW* manual by selecting **Start»All Programs»National Instruments»LabVIEW»LabVIEW Manuals** or by navigating to the `labview\manuals` directory and opening `LV_Getting_Started.pdf`.

Use the *LabVIEW Help*, available by selecting **Help»Search the LabVIEW Help** in LabVIEW, to access information about LabVIEW programming concepts, step-by-step instructions for using LabVIEW, and reference information about LabVIEW VIs, functions, palettes, menus, and tools. Refer to the following locations on the **Contents** tab of the *LabVIEW Help* for information about NI-DAQmx:

- **Getting Started»Getting Started with DAQ**—Includes overview information and a tutorial to learn how to take an NI-DAQmx measurement in LabVIEW using the DAQ Assistant.
- **VI and Function Reference»Measurement I/O VIs and Functions**—Describes the LabVIEW NI-DAQmx VIs and properties.
- **Taking Measurements**—Contains the conceptual and how-to information you need to acquire and analyze measurement data in LabVIEW, including common measurements, measurement fundamentals, NI-DAQmx key concepts, and device considerations.

## LabWindows/CVI

The **Data Acquisition** book of the *LabWindows/CVI Help* contains measurement concepts for NI-DAQmx. This book also contains *Taking an NI-DAQmx Measurement in LabWindows/CVI*, which includes step-by-step instructions about creating a measurement task using the DAQ Assistant. In LabWindows™/CVI™, select **Help»Contents**, then select **Using LabWindows/CVI»Data Acquisition**.

The **NI-DAQmx Library** book of the *LabWindows/CVI Help* contains API overviews and function reference for NI-DAQmx. Select **Library Reference»NI-DAQmx Library** in the *LabWindows/CVI Help*.

## Measurement Studio

If you program your NI-DAQmx-supported device in Measurement Studio using Visual C++, Visual C#, or Visual Basic .NET, you can interactively create channels and tasks by launching the DAQ Assistant from MAX or from within Visual Studio .NET. You can generate the configuration code based on your task or channel in Measurement Studio. Refer to the *DAQ Assistant Help* for additional information about generating code. You also can create channels and tasks, and write your own applications in your ADE using the NI-DAQmx API.

For help with NI-DAQmx methods and properties, refer to the NI-DAQmx .NET Class Library or the NI-DAQmx Visual C++ Class Library included in the *NI Measurement Studio Help*. For general help with programming in Measurement Studio, refer to the *NI Measurement Studio Help*, which is fully integrated with the Microsoft Visual Studio .NET help. To view

this help file in Visual Studio .NET, select **Measurement Studio»NI Measurement Studio Help**.

To create an application in Visual C++, Visual C#, or Visual Basic .NET, follow these general steps:

1. In Visual Studio .NET, select **File»New»Project** to launch the New Project dialog box.
2. Find the Measurement Studio folder for the language you want to create a program in.
3. Choose a project type. You add DAQ tasks as a part of this step.

## ANSI C without NI Application Software

The *NI-DAQmx Help* contains API overviews and general information about measurement concepts. Select **Start»All Programs»National Instruments»NI-DAQ»NI-DAQmx Help**.

The *NI-DAQmx C Reference Help* describes the NI-DAQmx Library functions, which you can use with National Instruments data acquisition devices to develop instrumentation, acquisition, and control applications. Select **Start»All Programs»National Instruments»NI-DAQ»NI-DAQmx C Reference Help**.

## .NET Languages without NI Application Software

With the Microsoft .NET Framework version 1.1 or later, you can use NI-DAQmx to create applications using Visual C# and Visual Basic .NET without Measurement Studio. You need Microsoft Visual Studio .NET 2003 or Microsoft Visual Studio 2005 for the API documentation to be installed.

The installed documentation contains the NI-DAQmx API overview, measurement tasks and concepts, and function reference. This help is fully integrated into the Visual Studio .NET documentation. To view the NI-DAQmx .NET documentation, go to **Start»Programs»National Instruments»NI-DAQ»NI-DAQmx .NET Reference Help**. Expand **NI Measurement Studio Help»NI Measurement Studio .NET Class Library»Reference** to view the function reference. Expand **NI Measurement Studio Help»NI Measurement Studio .NET Class Library»Using the Measurement Studio .NET Class Libraries** to view conceptual topics for using NI-DAQmx with Visual C# and Visual Basic .NET.

To get to the same help topics from within Visual Studio, go to **Help»Contents**. Select **Measurement Studio** from the **Filtered By** drop-down list and follow the previous instructions.

# Device Documentation and Specifications

NI-DAQmx includes the Device Document Browser, which contains online documentation for supported DAQ and SCXI devices, such as documents describing device pinouts, features, and operation. You can find, view, and/or print the documents for each device using the Device Document Browser at any time by inserting the CD. After installing the Device Document Browser, device documents are accessible from **Start»All Programs»National Instruments»NI-DAQ»Browse Device Documentation**.



**Note** You can download these documents at [ni.com/manuals](http://ni.com/manuals).

## NI-DAQmx Base (Linux/Mac OS X/LabVIEW PDA 8.x)

The *NI-DAQmx Base Getting Started Guide* describes how to install your NI-DAQmx Base software, your NI-DAQmx Base-supported DAQ device, and how to confirm that your device is operating properly. In Windows, select **Start»All Programs»National Instruments»NI-DAQmx Base»Documentation»Getting Started Guide**.

*Getting Started with NI-DAQmx Base for Linux and Mac Users* describes how to install your NI-DAQmx Base software, your NI-DAQmx Base-supported DAQ device, and how to confirm that your device is operating properly on your Mac/Linux machine.

The *NI-DAQmx Base Readme* lists which devices are supported by this version of NI-DAQmx Base. In Windows, select **Start»All Programs»National Instruments»NI-DAQmx Base»DAQmx Base Readme**.

The *NI-DAQmx Base VI Reference Help* contains VI reference and general information about measurement concepts. In LabVIEW, select **Help»NI-DAQmx Base VI Reference Help**.

The *NI-DAQmx Base C Reference Help* contains C reference and general information about measurement concepts. In Windows, select **Start»All Programs»National Instruments»NI-DAQmx Base»Documentation»C Function Reference Help**.



**Note** All NI-DAQmx Base documentation for Linux is installed at `/usr/local/natinst/nidaqmxbase/documentation`.



**Note** All NI-DAQmx Base documentation for Mac OS X is installed at `/Applications/National Instruments/NI-DAQmx Base/documentation`.

## Training Courses

If you need more help getting started developing an application with NI products, NI offers training courses. To enroll in a course or obtain a detailed course outline, refer to [ni.com/training](http://ni.com/training).

## Technical Support on the Web

For additional support, refer to [ni.com/support](http://ni.com/support) or [zone.ni.com](http://zone.ni.com).

## Installing the Software

---

Software support for the NI USB-9215 Series for Windows Vista/XP/2000 is provided by NI-DAQmx or NI-DAQmx Base depending on the software you are using. Software support for your hardware depends on the carrier being used. Refer to Table 1 for a list of software support.

**Table 1.** Devices and Corresponding Components

Devices	Carrier	Software Support
NI USB-9215	NI 9161	NI-DAQmx Base 2.2 and previous
NI USB-9215A	NI 9162	NI-DAQmx or NI-DAQmx Base 3.0 or later
NI USB-9215A BNC	NI 9162	NI-DAQmx or NI-DAQmx Base 3.0 or later

The *DAQ Getting Started Guide*, which you can download at [ni.com/manuals](http://ni.com/manuals), offers NI-DAQmx users step-by-step instructions for installing software and hardware, configuring channels and tasks, and getting started developing an application.



**Note** For information about non-Windows operating system support, refer to [ni.com/info](http://ni.com/info) and enter BaseGSGML.



**Note** If your device uses NI-DAQmx Base, refer to [ni.com](http://ni.com) to download the software.

## Installing Other Software

If you are using other software, refer to the installation instructions that accompany your software.

## Example Programs

The NI-DAQmx CD contains example programs that you can use to get started programming with the NI USB-9215 Series. Refer to the *NI-DAQmx for USB Devices Getting Started Guide* that shipped with your



device, and is also accessible from **Start»All Programs»National Instruments»NI-DAQ**, for more information.

The NI-DAQmx Base software ships with example programs you can use to get started programming with the NI USB-9215 Series. Refer to the *NI-DAQmx Base Getting Started Guide* that shipped with your device, and is also accessible from **Start»All Programs»National Instruments»NI-DAQmx Base»Documentation**, for more information.

## Installing the NI USB-9215 Series Device

---

Before installing the device, you must install the software you plan to use with the device. Refer to the [Related Documentation](#) section of this guide and the documentation included with the software for more information.

### Installing the NI 9215 in the NI USB-9161/9162 Carrier

The NI 9215 module and NI USB-9161/9162 carrier are packaged separately. Refer to Figures 4 and 5 while completing the following assembly steps:

1. Make sure that no signals are connected to the NI 9215 module.
2. Remove the protective cover from the 15-pin D-SUB connector.
3. Align the I/O module with the carrier, as shown in Figure 4.

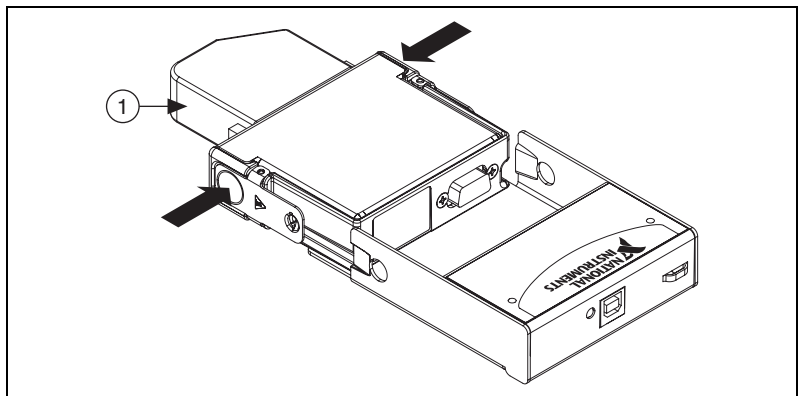

1 High Voltage Screw Terminal Backshell

**Figure 4.** Module Installation

4. Squeeze the latches and insert the NI 9215 module into the carrier.
5. Press firmly on the connector side of the NI 9215 module until the latches lock the module into place.

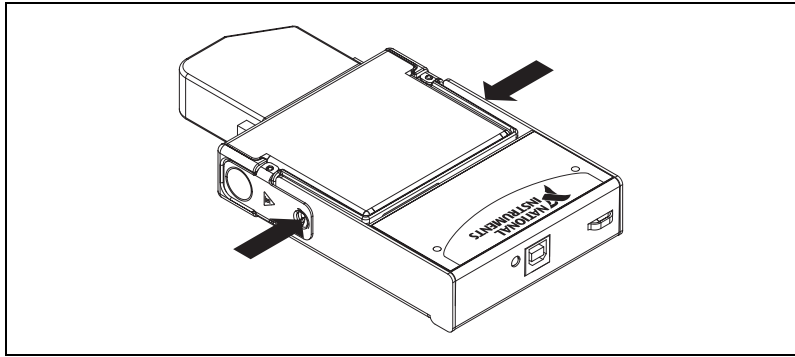

**Figure 5.** Locking Module into Place

## Mounting the NI USB-9215 Series to a Panel

Thread inserts are located in the NI USB-9215 Series for mounting it to a panel. Refer to Figure 6 for dimensions.

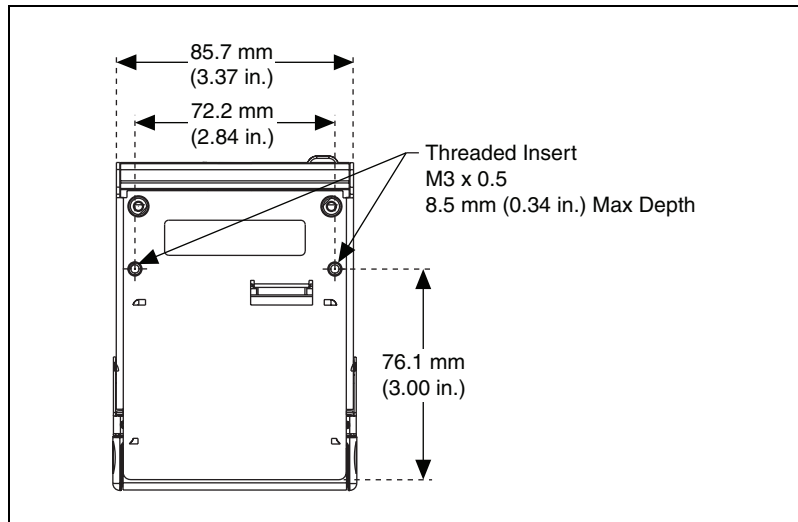

**Figure 6.** NI USB-9215 Series Dimensions in Millimeters (Inches)

## Connecting the NI USB-9215 Series to a Computer

Plug one end of the USB cable into the NI USB-9215 Series and the other end into an available USB port on the computer.

## LED Indicator

The NI USB-9215 Series device has a green LED next to the USB connector. The LED indicator indicates device status, as listed in Table 2. When the device is connected to a USB port, the LED blinks steadily to indicate that the device is initialized and is receiving power from the connection.

If the LED is not blinking, it may mean that the device is not initialized or the computer is in standby mode. In order for the device to be recognized, the device must be connected to a computer that has NI-DAQmx or NI-DAQmx Base installed on it. If your device is not blinking, make sure your computer has the latest version of NI-DAQmx or NI-DAQmx Base installed on it, and the computer is not in standby mode.

**Table 2.** LED State/Device Status

LED State	Device Status
Not lit	Device not connected or in suspend.
On, not blinking	Device connected, but no module installed.
Single-blink	Operating normally.
Double-blink	NI USB-9215A only—Connected to USB Full-Speed port. Device performance might be affected. Refer to the <a href="#">Specifications</a> section for more information.
Quadruple-blink	Device error. Refer to <a href="http://ni.com/support">ni.com/support</a> .

## Wiring the NI USB-9215 Series Device

The NI USB-9215 Series provides connections for four differential analog input channels. The NI USB-9215A with BNC has four BNC connectors.



**Caution** A high voltage screw terminal backshell must be installed when using hazardous voltages ( $>42.4 V_{pk}$ , 60 VDC) with the NI USB-9215 Series.



**Note** The NI 9932 10-terminal, detachable, high voltage, screw-terminal backshell accessory works with the NI USB-9215 Series and is available from [ni.com](http://ni.com). For more information about installing the backshell, refer to the [Assembling the High Voltage Screw Terminal Backshell](#) section.

Each channel of the NI USB-9215 Series has a terminal or center pin to which you can connect the positive voltage signal, AI+, and a terminal or shield to which you can connect the negative voltage signal, AI-. The NI USB-9215 with screw terminal also has a common terminal, COM, that is internally connected to the isolated ground reference of the module. Refer to Table 3 for the terminal assignments of the NI USB-9215 with screw terminal. Refer to Figure 7 for the pin assignments of the NI USB-9215A with BNC.

**Table 3.** Terminal Assignments

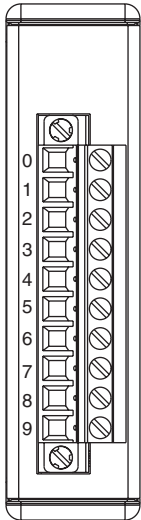
Module	Terminal	Signal
	0	AI0+
	1	AI0-
	2	AI1+
	3	AI1-
	4	AI2+
	5	AI2-
	6	AI3+
	7	AI3-
	8	No Connection
	9	Common (COM)

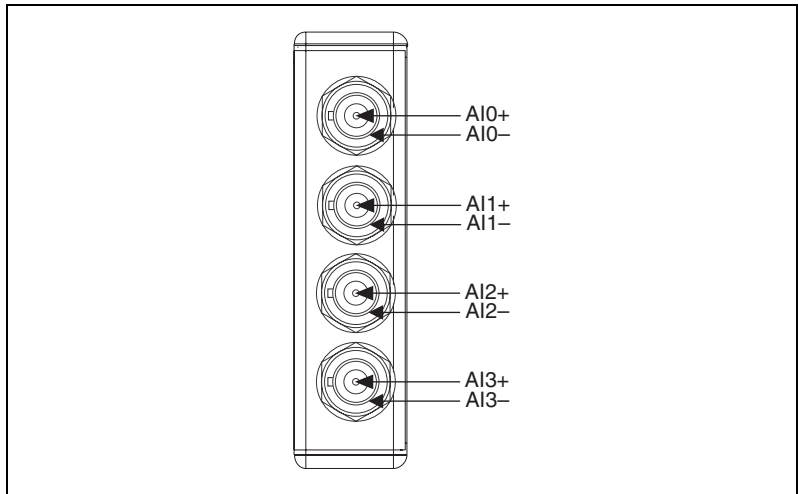

**Figure 7.** BNC Connector Assignments

## Connecting Differential Voltage Signals to the NI USB-9215 Series

For grounded differential signals, connect the positive voltage signal to AI+ and the negative signal to AI-. For the NI USB-9215 with screw terminal, connect the signal reference to the COM terminal.

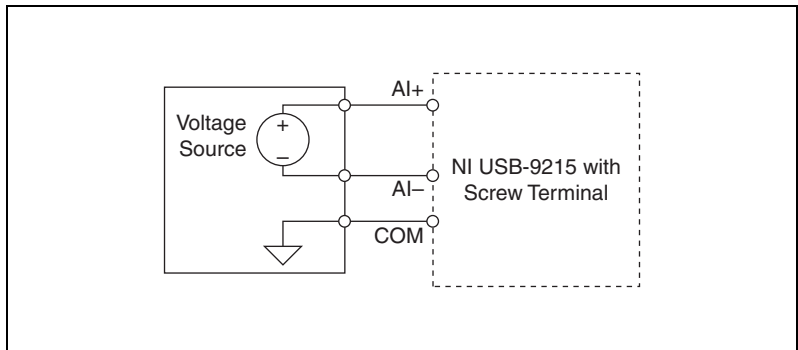

**Figure 8.** Connecting a Grounded Differential Voltage Signal to the NI USB-9215 (NI USB-9215 with Screw Terminal Shown)

For floating differential signals, the voltage source may go outside of the common-mode signal range of the NI USB-9215 with screw terminal. If the voltage source is outside of the common-mode range, data read by the NI USB-9215 is not accurate. To keep the voltage source within the common-mode range, connect the negative lead of the signal to COM through a 1 M $\Omega$  resistor, as shown in Figure 9. The NI USB-9215A with

BNC has internal circuitry that keeps the voltage source within the common-mode range.

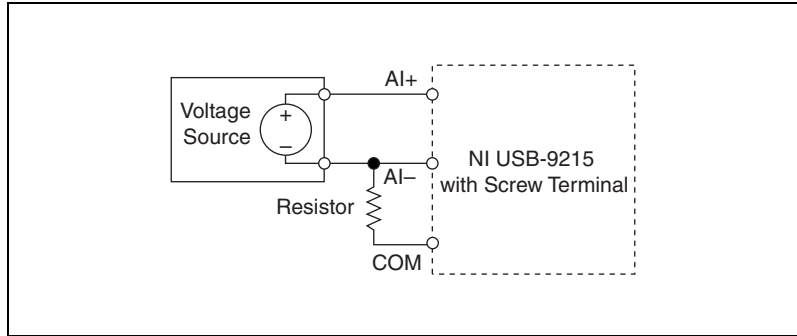

**Figure 9.** Connecting a Floating Differential Voltage Signal (NI USB-9215 with Screw Terminal Shown)

## Connecting Single-Ended Voltage Signals to the NI USB-9215 Series

Connect the positive voltage signal to AI+. Connect the ground signal to AI-. For the NI USB-9215 with screw terminal, you must also connect the ground signal to the COM terminal to keep the common-mode voltage in the specified range. For more information about the common-mode voltage range, refer to the [Specifications](#) section.

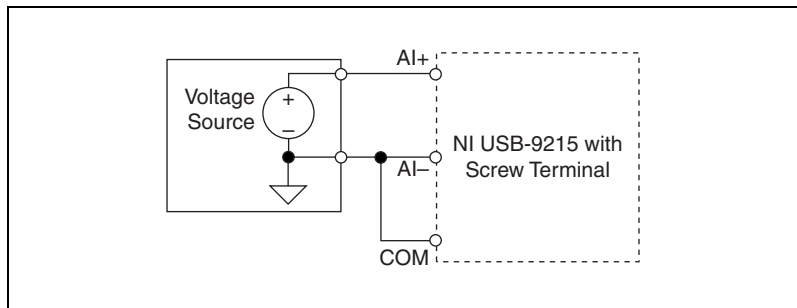
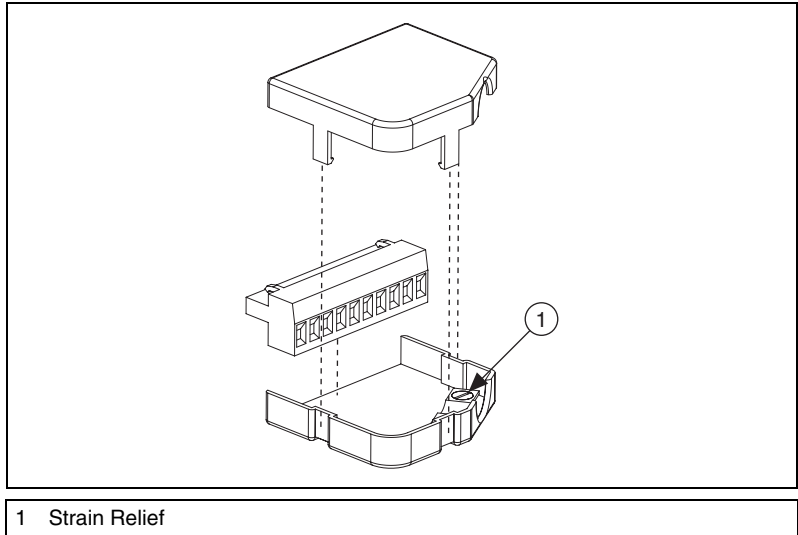

**Figure 10.** Connecting a Single-Ended Voltage Signal to the NI USB-9215 (NI USB-9215 with Screw Terminal Shown)

## Assembling the High Voltage Screw Terminal Backshell

The high voltage screw terminal backshell must be installed when using hazardous voltages ( $>42.4 V_{pk}$ , 60 VDC). Refer to Figure 11 while completing the following steps to assemble the backshell:

1. Connect the leads to the screw terminal and secure with the strain relief.
2. Finish by snapping the backshell around the connector.



**Figure 11.** High Voltage Screw Terminal Backshell

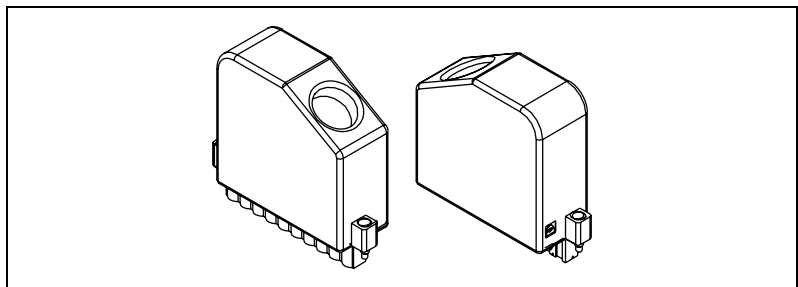

**Figure 12.** Assembled High Voltage Screw Terminal Backshell

# NI USB-9215 Series Circuitry

The NI USB-9215 Series channels share a common ground. The NI USB-9215 protects each channel from overvoltages. For more information about overvoltage protection, refer to the [Specifications](#) section. The signal is buffered and conditioned by the instrumentation amplifier and is then sampled by a 16-bit ADC. The channels have independent track-and-hold amplifiers that allow you to sample all four channels simultaneously.

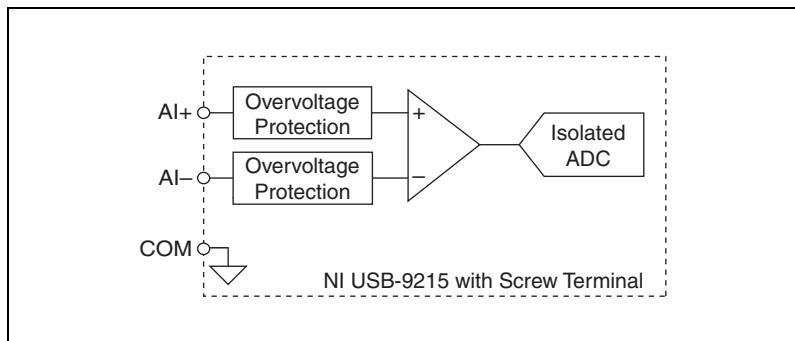

**Figure 13.** Input Circuitry for One Channel on the NI USB-9215 with Screw Terminal

The NI USB-9215A with BNC has a resistor that ensures the input voltage does not drift outside of the common-mode range.

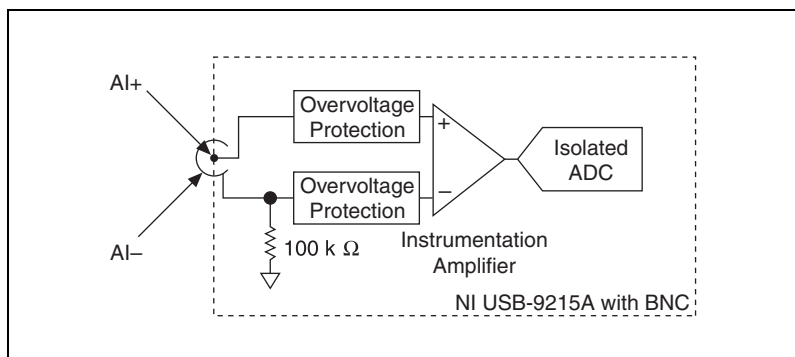

**Figure 14.** Input Circuitry for One Channel on the NI USB-9215A with BNC



# Specifications

---

The following specifications are typical for the range 0 to 60 °C unless otherwise noted. All voltages are relative to COM unless otherwise noted.

## Input Characteristics

Number of channels ..... 4 analog input channels

ADC resolution ..... 16 bits

Type of ADC..... Successive approximation register (SAR)

Max sampling rate<sup>1</sup>  
NI USB-9215

Highest Channel Number In Task	Maximum Sample Rate
0	20 kS/sec
1	10 kS/sec
2	6.67 kS/sec
3	5 kS/sec

NI USB-9215A<sup>2</sup>..... 100 kS/s (per channel)

NI USB-9215A with BNC<sup>2</sup>..... 100 kS/s (per channel)

Operating voltage range (AI+ to AI-)

Typical ..... ±10 V (not software selectable)

Maximum working voltage (signal + common mode)

With screw terminal..... Each channel must remain within ±10.2 V of common

With BNC ..... All inputs must remain within ±10.2 V of the average AI- inputs

Overvoltage protection..... ±30 V

---

<sup>1</sup> Might be system dependent.

<sup>2</sup> Full performance requires the use of a USB 2.0 Hi-Speed host controller and USB 2.0 hubs.

Conversion time

Channel 0 only.....	4.4 $\mu$ s
Channels 0 and 1 .....	6 $\mu$ s
Channels 0, 1, and 2 .....	8 $\mu$ s
Channels 0, 1, 2, and 3 .....	10 $\mu$ s

Accuracy

<b>Error</b>	<b>Percent of Reading (Gain Error)</b>	<b>Percent of Range (Offset Error)*</b>
Calibrated max (0 to 60 °C)	0.2%	0.082%
Calibrated typ (25 °C, $\pm 5$ °C)	0.02%	0.014%
Uncalibrated max (0 to 60 °C)	1.05%	0.82%
Uncalibrated typ (25 °C, $\pm 5$ °C)	0.6%	0.38%
* Range equals 10.4 V.		

Stability

Offset drift .....	60 $\mu$ V/°C
Gain drift .....	10 ppm/°C

CMRR (at 60 Hz) .....-73 dB min

Input bandwidth (-3 dB).....420 kHz min

Input impedance

Resistance

With screw terminal .....	1 G $\Omega$
With BNC (between any two AI- terminals) .....	200 k $\Omega$

Capacitance.....25 pF

Input bias current .....

10 nA

Input noise

RMS.....	1.2 LSB <sub>rms</sub>
Peak-to-peak .....	7 LSB

Crosstalk .....-80 dB

Settling time (to 2 LSBs)	
With screw terminal	
10 V step.....	10 $\mu$ s
20 V step.....	15 $\mu$ s
With BNC	
10 V step.....	25 $\mu$ s
20 V step.....	35 $\mu$ s
No missing codes .....	15 bits guaranteed
DNL .....	-1.9 to 2 LSB max
INL.....	$\pm$ 6 LSB max

## Power Requirements

Power consumption from USB .....	500 mA, max
Suspend mode .....	2.5 mA, max

## Bus Interface

USB specifications	
NI USB-9215 .....	USB 2.0 Full-Speed
NI USB-9215A .....	USB 2.0 Hi-Speed
NI USB-9215A BNC.....	USB 2.0 Hi-Speed

## Physical Characteristics

Dimensions	
With combicon.....	14.0 cm $\times$ 8.8 cm $\times$ 2.5 cm (5.52 in. $\times$ 3.47 in. $\times$ 1.00 in.)
With BNC .....	14.2 cm $\times$ 8.8 cm $\times$ 2.5 cm (5.54 in. $\times$ 3.47 in. $\times$ 1.00 in.)
Screw terminal wiring.....	12 to 24 AWG copper conductor wire with 10 mm (0.39 in.) of insulation stripped from the end
Torque for screw terminals .....	0.5–0.6 N $\cdot$ m (4.4–5.3 lb $\cdot$ in.)
Weight	
With screw terminal.....	Approx. 250 g (8.8 oz)
With BNC .....	Approx. 275 g (9.6 oz)

# Safety

If you need to clean the module, wipe it with a dry towel.

## Safety Voltages

### NI USB-9215 with Screw Terminal Safety Voltages

Connect only voltages that are within these limits.

Channel-to-COM ..... $\pm 30$  V max

#### Isolation

Channel-to-channel.....No isolation between channels

Channel-to-earth ground

Withstand .....2,300 V<sub>rms</sub>, 5 seconds max

Continuous .....250 V<sub>rms</sub>,  
Measurement Category II

Measurement Category II is for measurements performed on circuits directly connected to the electrical distribution system. This category refers to local-level electrical distribution, such as that provided by a standard wall outlet (for example, 115 V for U.S. or 230 V for Europe). Do not use this module with Measurement Category III or IV voltages.

### NI USB-9215A with BNC Safety Voltages

Connect only voltages that are within these limits.

AI+-to-AI- ..... $\pm 30$  V max

#### Isolation

Channel-to-channel.....No isolation between channels

Channel-to-earth ground

Withstand .....1,500 V<sub>rms</sub>, 5 seconds max

Continuous .....60 VDC,  
Measurement Category I

Measurement Category I is for measurements performed on circuits not directly connected to the electrical distribution system referred to as *MAINS* voltage. *MAINS* is a hazardous live electrical supply system that powers equipment. This category is for measurements of voltages from specially protected secondary circuits. Such voltage measurements include signal levels, special equipment, limited-energy parts of equipment, circuits powered by regulated low-voltage sources, and electronics. Do not use this module with Measurement Category II, III, or IV voltages.

## Safety Standards

This product is designed to meet the requirements of the following standards of safety for electrical equipment for measurement, control, and laboratory use:

- IEC 61010-1, EN-61010-1
- UL 61010-1, CSA 61010-1



**Note** For UL and other safety certifications, refer to the product label or visit [ni.com/certification](http://ni.com/certification), search by model number or product line, and click the appropriate link in the Certification column.

## Hazardous Locations

The NI USB-9215 is not certified for use in hazardous locations.

## Environmental

The NI USB-9215 Series is intended for indoor use only.

Operating temperature  
(IEC 60068-2-1, IEC 60068-2-2)..... 0 to 60 °C

Storage temperature  
(IEC 60068-2-1, IEC 60068-2-2)..... -40 to 85 °C

Operating humidity  
(IEC 60068-2-56)..... 10 to 90% RH, noncondensing

Storage humidity  
(IEC 60068-2-56)..... 5 to 95% RH, noncondensing

Maximum altitude ..... 2,000 m

Pollution Degree (IEC 60664) ..... 2

## Electromagnetic Compatibility

The NI USB-9215 Series is designed to meet the requirements of the following standards of EMC for electrical equipment for measurement, control, and laboratory use:

- EN 61326 EMC requirements; Minimum Immunity
- EN 55011 Emissions; Group 1, Class A
- CE, C-Tick, ICES, and FCC Part 15 Emissions; Class A



**Note** For EMC compliance, operate this device with double-shielded cables.

## CE Compliance

This product meets the essential requirements of applicable European Directives, as amended for CE marking, as follows:

- 2006/95/EC; Low-Voltage Directive (safety)
- 2004/108/EC; Electromagnetic Compatibility Directive (EMC)



**Note** Refer to the Declaration of Conformity (DoC) for this product for any additional regulatory compliance information. To obtain the DoC for this product, visit [ni.com/certification](http://ni.com/certification), search by model number or product line, and click the appropriate link in the Certification column.

## Environmental Management

National Instruments is committed to designing and manufacturing products in an environmentally responsible manner. NI recognizes that eliminating certain hazardous substances from our products is beneficial not only to the environment but also to NI customers.

For additional environmental information, refer to the *NI and the Environment* Web page at [ni.com/environment](http://ni.com/environment). This page contains the environmental regulations and directives with which NI complies, as well as other environmental information not included in this document.

## Waste Electrical and Electronic Equipment (WEEE)



**EU Customers** At the end of their life cycle, all products *must* be sent to a WEEE recycling center. For more information about WEEE recycling centers and National Instruments WEEE initiatives, visit [ni.com/environment/weee.htm](http://ni.com/environment/weee.htm).

## 电子信息产品污染控制管理办法（中国 RoHS）



**中国客户** National Instruments 符合中国电子信息产品中限制使用某些有害物质指令 (RoHS)。关于 National Instruments 中国 RoHS 合规性信息, 请登录 [ni.com/environment/rohs\\_china](http://ni.com/environment/rohs_china)。(For information about China RoHS compliance, go to [ni.com/environment/rohs\\_china](http://ni.com/environment/rohs_china).)

## Calibration

You can obtain the calibration certificate for the NI USB-9215 Series at [ni.com/calibration](http://ni.com/calibration).

Calibration interval .....1 year

# Where to Go for Support

---

The National Instruments Web site is your complete resource for technical support. At [ni.com/support](http://ni.com/support) you have access to everything from troubleshooting and application development self-help resources to email and phone assistance from NI Application Engineers.

National Instruments corporate headquarters is located at 11500 North Mopac Expressway, Austin, Texas, 78759-3504. National Instruments also has offices located around the world to help address your support needs. For telephone support in the United States, create your service request at [ni.com/support](http://ni.com/support) and follow the calling instructions or dial 512 795 8248. For telephone support outside the United States, contact your local branch office:

Australia 1800 300 800, Austria 43 662 457990-0,  
Belgium 32 (0) 2 757 0020, Brazil 55 11 3262 3599,  
Canada 800 433 3488, China 86 21 5050 9800,  
Czech Republic 420 224 235 774, Denmark 45 45 76 26 00,  
Finland 358 (0) 9 725 72511, France 01 57 66 24 24,  
Germany 49 89 7413130, India 91 80 41190000, Israel 972 3 6393737,  
Italy 39 02 41309277, Japan 0120-527196, Korea 82 02 3451 3400,  
Lebanon 961 (0) 1 33 28 28, Malaysia 1800 887710,  
Mexico 01 800 010 0793, Netherlands 31 (0) 348 433 466,  
New Zealand 0800 553 322, Norway 47 (0) 66 90 76 60,  
Poland 48 22 3390150, Portugal 351 210 311 210, Russia 7 495 783 6851,  
Singapore 1800 226 5886, Slovenia 386 3 425 42 00,  
South Africa 27 0 11 805 8197, Spain 34 91 640 0085,  
Sweden 46 (0) 8 587 895 00, Switzerland 41 56 2005151,  
Taiwan 886 02 2377 2222, Thailand 662 278 6777,  
Turkey 90 212 279 3031, United Kingdom 44 (0) 1635 523545

National Instruments, NI, ni.com, and LabVIEW are trademarks of National Instruments Corporation. Refer to the *Terms of Use* section on [ni.com/legal](http://ni.com/legal) for more information about National Instruments trademarks. Other product and company names mentioned herein are trademarks or trade names of their respective companies. For patents covering National Instruments products, refer to the appropriate location: **Help»Patents** in your software, the `patents.txt` file on your CD, or [ni.com/patents](http://ni.com/patents).