

Intellio C218 Turbo/PCI User's Manual

A High Performance 8 Port Async Board for PCI Bus

March. 1999 (3rd Edition)

The content of this manual is also available in CD-ROM and at Moxa Web Site.



Moxa Technologies Co., Ltd.

Tel: +866-2-8665-6373

Fax: +886-2-8665-6372

www.moxa.com

support@moxa.com.tw

Intellio C218 Turbo/PCI User's Manual

The software described in this manual is furnished under a license agreement and may be used only in accordance with the terms of the agreements.

Copyright Notice

Copyright © 1999 Moxa Technologies Co., Ltd.
All rights reserved.

Reproduction in any form without permission is prohibited.

Trademarks

MOXA is a registered trademark of Moxa Technologies Co., Ltd.
All other trademarks or registered marks in this manual belong to their respective manufacturers.

Disclaimer

Information in this document is subject to change without notice and does not represent a commitment on the part of Moxa.

Moxa provides this document "as is", without warranty of any kind, either expressed or implied, including, but not limited to, the particular purpose. Moxa may make improvements and/or changes in this manual or in the product(s) and/or the program(s) described in this manual at any time.

Information provided in this manual is intended to be accurate and reliable. However, Moxa Technologies assumes no responsibility for its use, or for any infringements of rights of the fourth parties which may result from its use.

This product could include technical or typographical errors. Changes are periodically made to the information herein; these changes may be incorporated in new editions of the publication.

MOXA Internet Services

Customer's satisfaction is always our number one concern. To ensure that customers get the full benefit of our services, Moxa Internet Services have been built for technical support, product inquiry, new driver update, user's manual update, etc.

The followings are the services we provide.

E-mail for technical support

address: *support@moxa.com.tw*

FTP site for free driver update

address: *ftp.moxa.com*

or

ftp.moxa.com.tw

user ID: *ftp*

password: *your_email_address*

World Wide Web (WWW) Site for product info

address: *www.moxa.com*

or

www.moxa.com.tw

About This Manual

This manual is composed of six Chapters and one Appendix. This manual is written for installer, system administrator and software programmer.

If you are a first-time installer and system administrator, we recommend you to go through the whole manual except Chapter 4.

If you are a software programmer, you may refer to Chapter 4 “Serial Programming Tools”.

If you need cable wiring information, please see Chapter “Connection Option (Opt8x) and Cable Wiring”.

If you encounter any problem during installation, please refer to Chapter “Troubleshooting”.

Chapter 1 Introduction

Overview and features for Intellio C218*Turbo*/PCI are described. Also check list and overall installation guide.

Chapter 2 Hardware Installation

Hardware installation for Intellio C218*Turbo*/PCI and connection option (Opt8x) is detailed.

Chapter 3 Software Installation

This Chapter details the software installation, configuration, driver loading/unloading, driver upgrade and removal for various operating systems: Windows NT, Windows 95/98 and UNIX.

Chapter 4 Serial Programming Tools

This Chapter roughly describes the programming tools for various O.S. platforms, including *PComm* under Windows NT, Windows 95/98 and standard UNIX system calls. Also RS-485 programming issue is covered (for Opt8J).

Chapter 5 Connection Option (Opt8x) and Cable Wiring

This Chapter describes the RS-232/422/485 cable wiring for each connection option (Opt8x).

Chapter 6 Troubleshooting

This Chapter describes the problems and possible answers for Intellio C218*Turbo*/PCI.

Appendix

Specification details, PCI, dual-ported RAM, UART, and DB62 pin outs are described.

Table of Contents

Introduction.....	1-1
Overview	1-1
Features.....	1-3
Check List	1-3
Installation Guide	1-5
Hardware Installation	2-1
Installing the Intellio C218Turbo/PCI Control Board	2-1
Installing Connection Option Opt8x.....	2-2
Operating Opt8J.....	2-4
Software Installation.....	3-1
Windows NT	3-1
Installing Driver	3-2
Configuring Board and Port.....	3-7
Adding/Removing Board	3-9
Updating Driver	3-9
Removing Driver	3-10
Windows 95/98	3-10
Installing Driver	3-11
Configuring Board and Port.....	3-19
Updating driver.....	3-23
Removing driver	3-23
UNIX	3-24
Installing Driver	3-24
MOXA TTY Device Naming Convention	3-27
Administration Utility - mxadm	3-28
Checking Board Initialization Status	3-35
Setting MOXA Ports to Terminal	3-35
Serial Programming Tools	4-1
Windows NT and Windows 95/98	4-1
Installation.....	4-1
<i>PComm</i> Programming Library	4-2
Utilities	4-2
UNIX	4-6
Programming the MOXA Ports.....	4-6

Extended UNIX ioctl() Commands.....	4-6
Utilities	4-12
RS-485 Programming for Opt8J.....	4-15
Connection Option (Opt8x) and Cable Wiring	5-1
RS-232 Cable Wiring for Opt8A/B/C/D/S	5-1
RS-422 Cable Wiring for Opt8J/F/Z	5-8
RS-485 Cable Wiring for Opt8J	5-10
RS-422/485 Impedance Matching.....	5-11
Troubleshooting	6-1
General Troubleshooting	6-1
Windows NT	6-2
Windows 95/98	6-3
UNIX	6-4
Technical Reference	A-1
Specifications.....	A-1
PCI.....	A-2
Dual-Ported RAM.....	A-2
UART 16C550C	A-3
DB62 Connector Pinouts	A-3

Introduction

Overview

Intellio - The Intelligent Multiport Serial I/O Solutions

The **Intellio C218Turbo/PCI** is an 8 port high performance intelligent serial interface board designed for 32-bit PCI bus with “**Plug and Play**” feature. It is suitable for remote access, industrial control and office automation, where a PC system needs to communicate with multiple modems, data acquisition equipment, serial printers and any other serial devices through RS-232/RS-422/RS-485 interfaces.

One Intellio C218Turbo/PCI board provides 8 serial ports. Up to **four** boards of Intellio C218Turbo/PCI may be used in the same system. See Section “Features” and Chapter “Hardware installation” for details.

PCI Solution

The board complies with PCI Spec. 2.1 and has neither switch nor jumper. Hardware configuration for IRQ and Memory addresses is automatically assigned by PCI BIOS. Hence, it is a must to have the board plugged first before installing software driver. For more PCI information, see Appendix “Technical Reference”.

Low Host Processor Overhead

The Intellio C218Turbo/PCI is equipped with a high performance processor (TMS320) and 512KB on-board memory to relieve the host’s CPU workload of all data and I/O handling tasks. A buffer holds transmitted and received data to prevent data loss.

ASIC Design, Compact Size

The Intellio C218*Turbo*/PCI is also equipped with MOXA customer-designed ASIC chip, which replaces lots of conventional IC and hence reduces the board to half-size, increases the operation performance, and lowers the failure rate of the board.

Surge/Isolation Protection

To prevent the boards from damage caused by lightning or high potential voltage, TVSS (Transient Voltage Surge Suppressor) and high potential difference protector technologies are introduced in some connection options to protect the multiport controller. This is critical to harsh environment such as factory, severe weather such as lightning, or other high interference situations.

Major Operating System Support

It supports most popular O.S. platforms from Windows NT, Windows 95/98, SCO UNIX/OpenServer, UNIX SVR4.2 and Linux with nice installation, configuration and performance.

Powerful Serial Comm Developing Tools

For application development, MOXA provides an easy-use serial communication library under Windows NT and Windows 95/98 (*Pcomm Lite*). Users can use this library to develop your own applications using Visual Basic, Visual C++, Borland Delphi, etc. Utilities, such as diagnostics, monitor, terminal emulation, etc., are included for testing, monitoring or debugging the communication status or terminal emulation or even file transferring.

Broad Applications

The Intellio C218*Turbo*/PCI is suitable for many applications. Here are a few:

- } Internet/Intranet Connection
- } Remote Access Application
- } Multi-user Application
- } Industrial Automation
- } Office Automation
- } Telecommunication

- } PC-based (vending) Machine or Kiosk System
- Point-of-Sale (POS) System

Features

The following is a summary of all the outstanding features of *Intellio C218Turbo/PCI*:

- % High speed serial communication channel» Max. 921.6 Kbps per port (Max. speed may be limited by certain connection option such as Opt8J, which supports max. speed 460.8 Kbps only.)
- % Low host processor overhead» On-board RISC processor TMS320
- % Sufficient data buffer» On-board buffer 512KB
- % Reliability» On-chip flow control guarantees no data loss
- % High circuit integration with MOXA state-of-the-art ASIC design
- % Compact size design
- % Easy Monitoring» TXD and RXD status indicators for each port on connection box
- % Various Connection options» RS-232/422/485, female/male DB25/DB9
- % Easy Installation» 32-bit PCI bus with Plug and Play capability
- % Ease of use» Window-style setup and diagnostics
- % Powerful Serial Comm Tool» EComm
- % Popular OS Support» Windows NT, Windows 95/98, UNIX, Linux

C218Turbo/PCI

Windows NT	D
Windows 95/98	D
SCO UNIX/OpenServer	D
UNIX SVR4.2	D

D: Driver supported by Moxa and shipped with product

Note: MOXA FTP service is available for driver download

Check List

Upon unpacking *Intellio C218Turbo/PCI* 8-port high performance intelligent async board, you should find the following common items included in the package:

- % One *Intellio C218Turbo/PCI* 8-port high performance async board

-
- %o Device driver diskettes:
 - } Windows NT and Windows 95/98 » ☒
 - } **PCComm Lite** » ☒
 - } UNIX » ☒
 - %o Intellio C218*Turbo*/PCI User's Manual (This Manual)
- You need also one of the following connection options:

Opt8A/Opt8B/Opt8S

- %o RS-232 connection box with 8 DB25 female/male/female ports, respectively (surge protection for Opt8S).
- %o 1.5 meter DB62 to DB62 cable.

Opt8C/Opt8D

- %o RS-232 octopus cable with 8 port male connectors, DB25 for Opt8C and DB9 for Opt8D (1 meter long).

Opt8F/Opt8Z

- %o RS-422 connection box with 8 port female DB25 connectors (isolation protection for Opt8F).
- %o 1.5 meter DB62 to DB62 cable.
- %o 110V or 220V adapter.

Opt8J

- %o RS-422/485 connection box with 8 port female DB25 connectors.
- %o 1.5 meter DB62 to DB62 cable.
- %o 110V or 220V adapter.

Installation Guide

This section gives a brief summary of how to install the *Intellio C218Turbo*/PCI under each supported operating system. Installation is simple and involves the following stages:

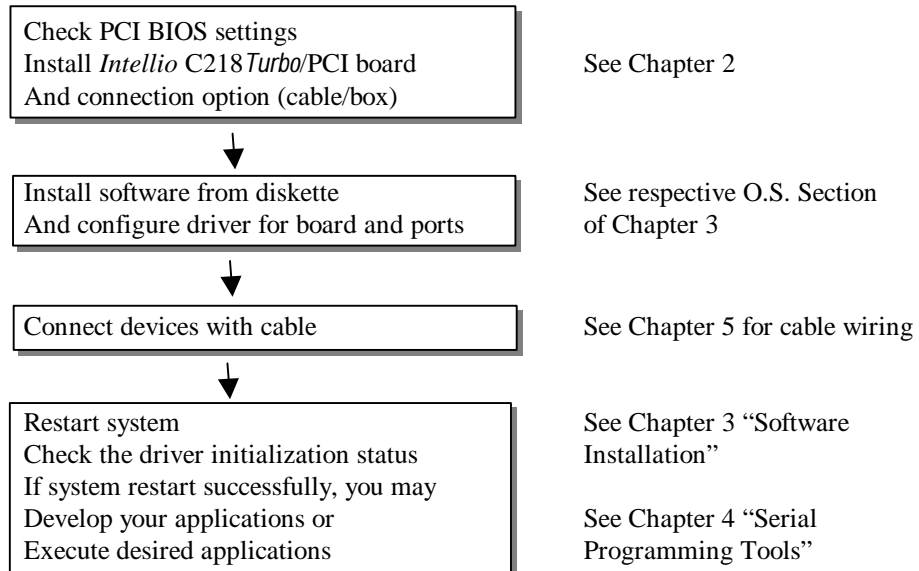

Hardware Installation

The installation of **Intellio C218Turbo/PCI** consists of hardware installation and software installation. For software installation, please refer to the respective section of operating systems in the next chapter. Hardware installation is stated in this chapter. The no-switch-no-jumper **Intellio C218Turbo/PCI** board's hardware configuration for IRQ and memory addresses is automatically assigned by **PCI BIOS**. Hence, **it is a must to have the board plugged first before installing software driver**. After this, simply install the control board into the PC and then connect one of the connection cable or box, Opt8A/B/C/D/S/J/F/Z. At the end of this Chapter, RS-422/RS-485 operation of Opt8J is described.

Installing the Intellio C218Turbo/PCI Control Board

Step 1: Power off the PC.

Warning! *Make sure your system is switched off before you start installing any board. If you don't, you may risk damaging your system and the board.*

Step 2: Remove the PC's cover.

Step 3: Remove the slot cover bracket if present.

Step 4: Plug the **Intellio C218Turbo/PCI** firmly into any free 32-bit PCI slot.

Step 5: Fasten the holding screw to make the Control Board fixed.

Step 6: Replace the system cover.

Step 7: Connect one of the connection box/cable (also adapter if required) detailed in the next Section.

Step 8: Power on PC and BIOS will automatically set the IRQ and memory address.

Note! Each board must occupy one unique IRQ and one unique memory address, which are assigned by PCI BIOS automatically. However, you may select the free IRQ number manually via PC's BIOS setup for PCI slot, but normally this method is not available for memory. The possible IRQ numbers are 2, 3, 4, 5, 9, 10, 11, 12, and 15.

Step 9: Proceed with software installation detailed in the next Chapter » **Software Installation**”.

Installing Connection Option Opt8x

Connect the Intellio C218*Turbo*/PCI with the one of the following connection options. Then you can connect your modem, serial printer, PC COM1/2, bar code reader, POS, instrument or any other serial devices to the DB25/DB9 connectors. Refer to Chapter “Connection Option (Opt8x) and Cable Wiring” for RS-232/RS-422/RS-485 cable wiring.

Opt8A/Opt8B/Opt8S

Hold one end of the DB62 cable and plug it into the DB62 connector on the bracket of the Intellio C218*Turbo*/PCI. Carefully screw it until it is tight. Then plug the other end of the cable to the RS-232 connection box's DB62 connector. Both ends of the cable are identical.

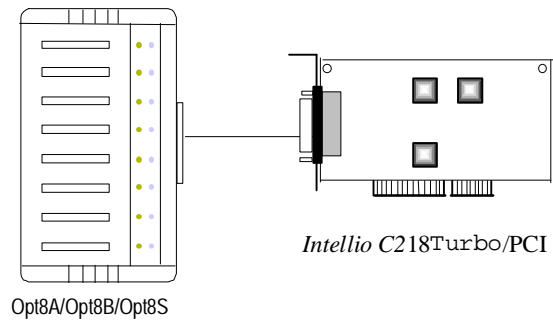

Opt8C/Opt8D

Hold one end of the DB62 cable and plug it into the DB62 connector on the bracket of the Intellio C218Turbo/PCI. Screw it carefully until it fits.

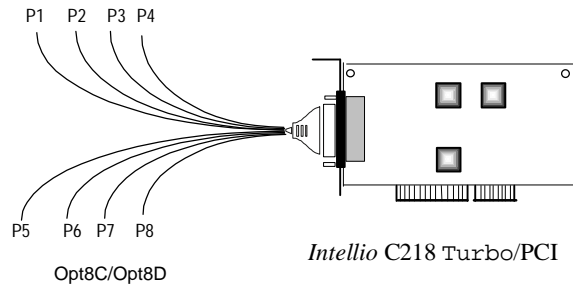

Opt8J/Opt8F/Opt8Z

Hold one end of the DB62 cable and plug it into the DB62 connector on the bracket of the Intellio C218Turbo/PCI. Carefully screw it until it is tight. Then plug the other end of the cable to the RS-422/RS-485 connection box's DB62 connector. Both ends of the cable are identical. After that, don't forget to apply power via the adapter to the Opt8J/F/Z.

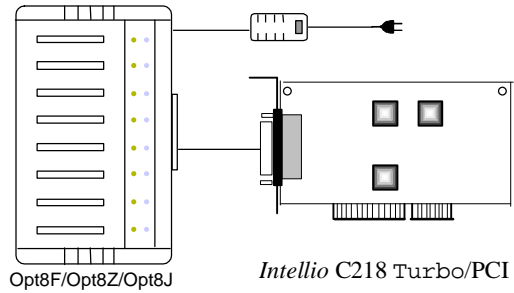

If you can't make the Intellio C218 Turbo/PCI work properly after installation, please refer to Chapter “Troubleshooting”.

Refer to Chapter “Connection Option (Opt8x) and Cable Wiring” for RS-232/RS-422/RS-485 cable wiring. And also to Chapter “Serial Programming Tools” for RS-232/RS-422/RS-485 programming details.

Operating Opt8J

Opt8J is the RS-422/485 connection box with 8 port female DB25 connectors for MOXA 8 port boards, including the Intellio C218 Turbo/PCI. There are 8-DIP switches on the side of the Opt8J. Each switch controls the communication mode (RS-422 or RS-485) of each port, respectively.

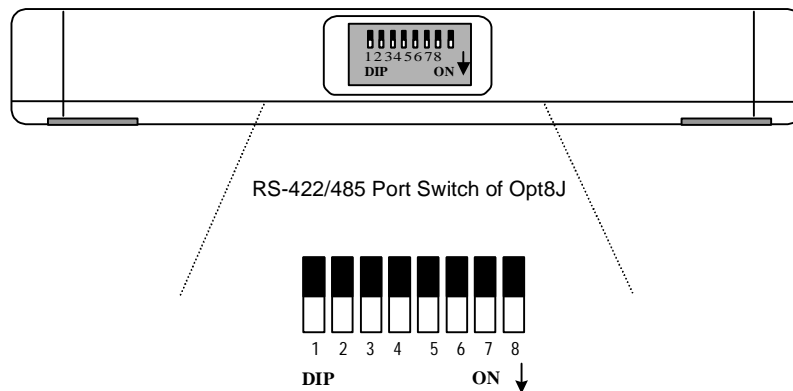

RS-422 Mode

Set the respective switch to **OFF** position to use RS-422 interface. This means the port is always ready to transmit and receive data simultaneously (full-duplex).

RS-485 Mode

The Opt8J supports only 2-wire RS-485 communication. Set the respective switch to **ON** position to use RS-485 interface. This means the port can transmit data only when RTS is asserted, and receive data only when RTS is not asserted (half-duplex).

Refer to Chapter “Connection Option (Opt8x) and Cable Wiring” for RS-422/RS-485 cable wiring. And also to Chapter “Serial Programming Tools” for Opt8J RS-485 programming details.

3

Software Installation

In this chapter, software driver installation, configuration and driver upgrade/removal procedures are described for various operating systems, including Windows NT, Windows 95/98 and UNIX. Before proceeding with software installation, complete the hardware installation detailed in the previous chapter.

However, if you need to develop applications, refer to the next chapter, “Serial Programming Tools”, for more information.

Windows NT

Windows NT supports up to **256** serial ports, from **COM1** to **COM256**. To fully integrate the advanced features of Windows NT, multi-process and multi-thread, pure 32-bit Windows NT device drivers are developed for Intellio C218*Turbo*/PCI and other MOXA multiport boards. The driver conforms to Win32 COMM API standard.

If you are the first time driver installer, please go directly to the section “Installing Driver”.

If you already have installed the driver and want to re-configure the board and port, add more boards or delete boards, please refer to the section “Configuring Board and Port”.

If you want to upgrade or even remove driver, please go to the section “Updating Driver” and section “Removing Driver”.

Installing Driver

The following is the procedure for installing the Intellio C218*Turbo*/PCI driver **for the first time** under Windows NT 4.0. Make sure the board(s) has(have) already been plugged in the system PCI slot.

1. Please Login NT as **Administrator**.
2. From [**Control Panel**], open [**Network**] icon and then select [**Adapters**] tab.
3. Click on [**Add**] button, then [**Have Disk...**] button for “Select Network Adapter”.
4. Specify the exact path for the driver diskette, **A:\WINDOWS.NT**. Then click on [**OK**] button.

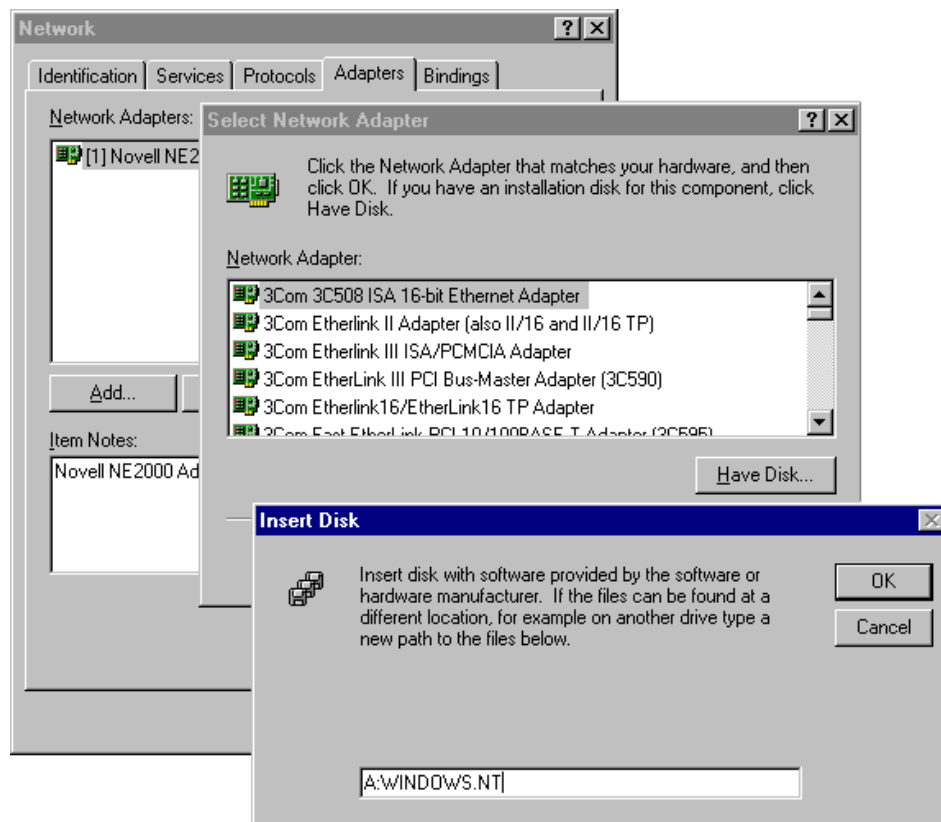

5. Select “**MOXA Intellio C218Turbo Multiport Board**” in the “Select OEM Option” dialog box, and then click [OK] to enter the “**MOXA Configuration Panel**” dialog box to start the installation.

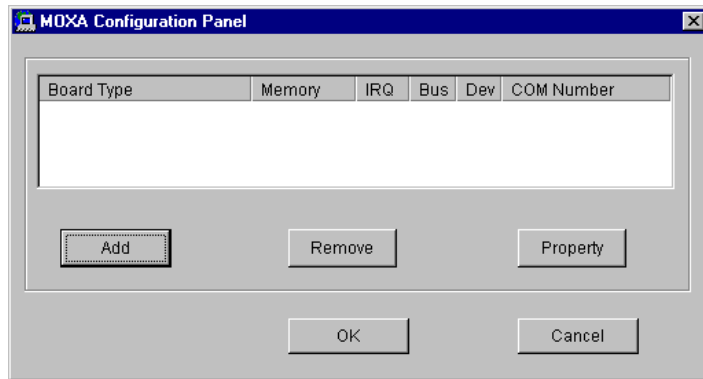

6. In the “**MOXA Configuration Panel**” dialog box, click [Add] to enter “**Property**” dialog box to add the Intellio C218Turbo/PCI board. Select the “**C218Turbo/PCI**” in the “Board Type” field.

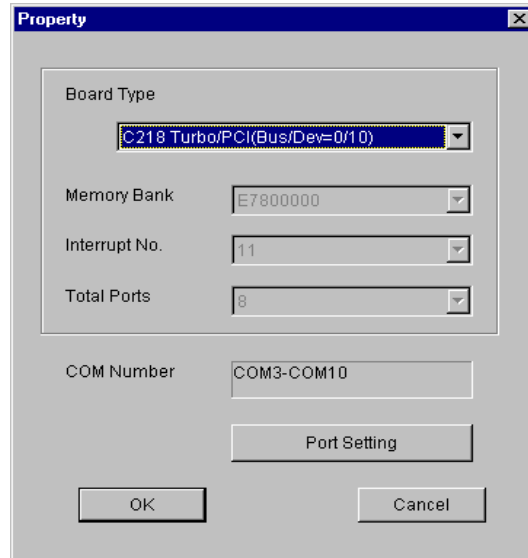

7. In the “Property” dialog, you may click on [Port Setting] button to pop up the following “Individual Port Setting” dialog to change the port COM number mappings.

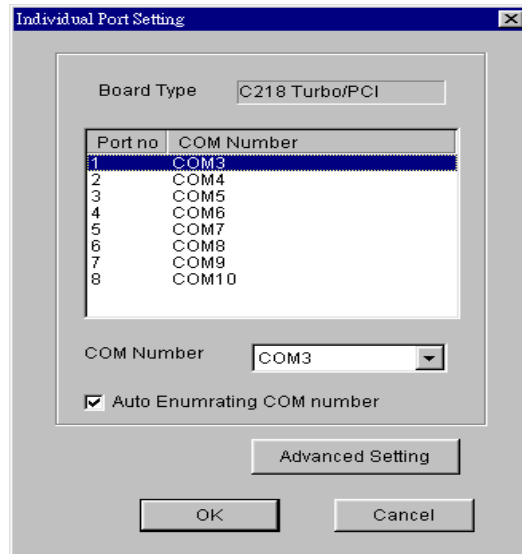

You have to set up all the ports of the board with the desired “**COM number**”, which should not conflict with other COM number in use. In this “Individual Port Setting” dialog box, you may have two ways to map the physical ports to COM numbers depending on the check box “**Auto Enumrating COM number**”.

- } **Sequential Port Mapping:** (Enable “Auto Enumrating COM number”) Specify the COM number of the first port and subsequent ports are mapped to continuous COM numbers. For instance, if first port is mapped to COM10, then second port is mapped to COM11 sequentially.
- } **Non-sequential Port Mapping:** (Disable “Auto Enumrating COM number”) Specify the COM number for individual port. For instance, the second port can be out of sequence, say COM18, while the first port is mapped to COM10.

In “Individual Port Setting” dialog, you may click on [**Advanced Setting**] button to tune the advanced features, “**UART FIFO**” and “**Transmission Mode**”, for each port for particular performance requirements.

Note ! You may skip the following settings and go directly to the next **step 8** if you do not require any particular performance tuning for the driver.

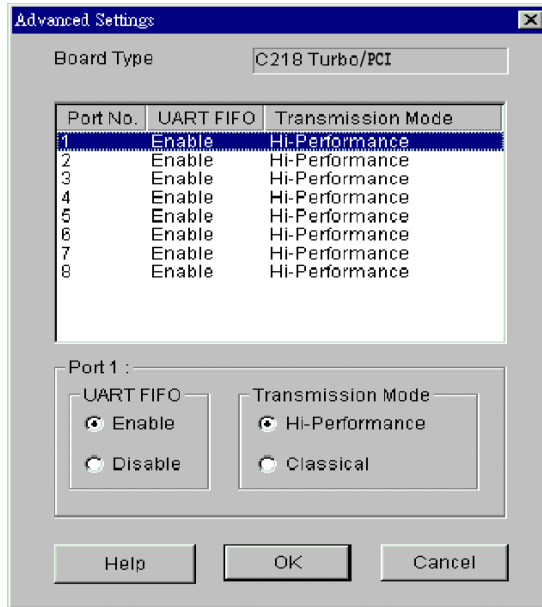

In the “Advanced Settings” dialog, you may customize the driver with the following two features:

} **UART FIFO**

Enable: You can set this feature to “Enable” (default) and gain best performance for the board.

Disable: You can set this feature to “Disable” to avoid from data loss when communicating with communication devices using S/W flow control.

} **Transmission Mode**

Hi-Performance Mode: This feature is set to “Hi-Performance” by default, which accelerates the reaction of data writing behavior by utilizing buffering technology. It lets your communication software reach maximum data throughput in large data transmission.

Classical Mode: It lets MOXA ports behave like generic COM ports. Transmission for small data packets would be more precisely and reliable.

-
- Click **[OK]** in the “Individual Port Setting” and the “Property” dialog boxes to go back to the “MOXA Configuration Panel” dialog box. Click **[OK]** to finish the configuration.

However, if you installed more than one board, click **[Add]** and repeat steps **6** and **7** to configure another board. Up to four Intellio C218*Turbo*/PCI boards can be installed in a system.

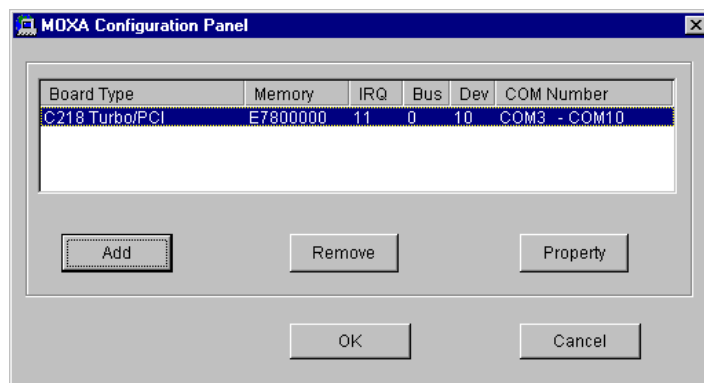

- When configuration is done, click on **[OK]** button for “Network ” dialog box.
- Restart Windows NT system.** The latest configuration will not take effect unless the system restarts.

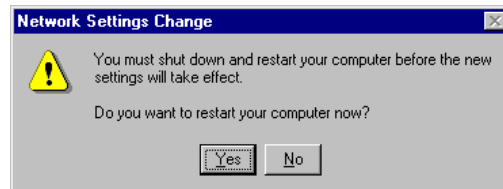

Note ! Please **double check** if all the Intellio C218*Turbo*/PCI components: Control Board, link cable and external cable/box, are connected and fastened tightly in order to ensure the system and driver will start successfully later.

- Once the system restarts, you may check the event log issued by MOXA drive to see if the ports of the board are initialized successfully.

- } Enter [**Administrative**] group, then open [**Event Viewer**] icon and then select [**Application Event Log**] item to check for successful message similar to "MOXA C218Turbo/PCI Multiport Board #1: addr(XXX) O.K." for each configured board.
- } If error message is like "MOXA C218Turbo/PCI Multiport Board #1 addr(XXX): IRQ(10) test failure!", refer to the "Troubleshooting" chapter for solutions.

Note ! Once the board and driver are installed and the system restarts successfully, you can start to develop applications by using *PComm* library (See Chapter "Serial Programming Tools") or using Microsoft Win32 API. Also you can execute any ready-made application such as *PComm* utility Terminal emulator (See Chapter "Serial Programming Tools") or HyperTerminal to transmit/receive data as well as Remote Access Service to provide dial-up networking capability.

Configuring Board and Port

If you already have installed the driver and want to re-configure the board and port, add more boards or delete boards, please follow the procedure below.

1. From [**Control Panel**], open [**Network**] icon and then select [**Adapters**] tab.
2. Select "MOXA C218Turbo Adapter" item in the "Installed Adapter Cards:"

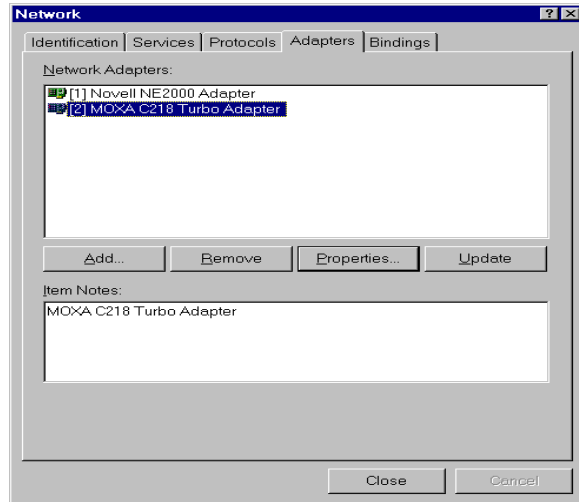

3. Click on [**Properties...**] button to start the “MOXA Configuration Panel” dialog.

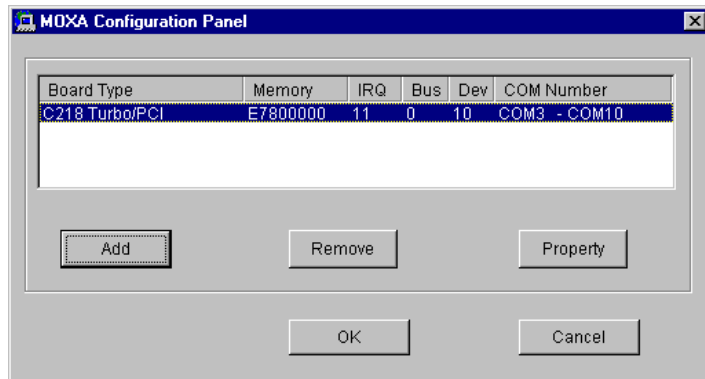

In this configuration panel, you may:

- } Click [**Property**] to enter “Property” dialog box to configure the selected board with the correct “**Total Ports**” and “**COM Number**”. Please see **steps 6 to 8** in the previous section, “Installing Driver”, for more details, except that the “Board Type” field is not supposed to be changed.

- } Click [**Add**] to add one more board that is not yet configured in the system. Up to four of Intellio C218 *Turbo*/PCI boards can be installed together as long as the memory and IRQ resources are sufficient and available in a system. Please see **steps 6 to 8** in the previous section, “Installing Driver”, for more details.
- } Click [**Remove**] to remove the board currently selected from the configured board list.
- } Click [**OK**] to confirm the configuration changes you made.
- } Click [**Cancel**] to leave the dialog with the configuration unchanged.

Adding/Removing Board

Following is the procedure to add/remove Intellio C218 *Turbo*/PCI boards after a first time installation. Note that **the presence of the board(s) is(are) required for adding boards.**

1. Power off the system.
2. Plug/unplug the boards in the system.
3. Power on the system.
4. Run the software configuration “MOXA Configuration Panel” to add/remove the boards, detailed in the previous “Configuring the Board and Port” section.

Updating Driver

To update the driver for the Intellio C218 *Turbo*/PCI board, simply remove the driver, as described in the next section, and then reinstall it as detailed in the “Installing Driver” section.

Removing Driver

To remove the driver for the Intellio C218*Turbo*/PCI board,

1. Open the [**Control Panel**], click on the [**Network**] icon and select the [**Adapters**] tab.
2. Select “**MOXA Intellio C218Turbo Adapter**” in the adapter list, then click on the [**Remove**] button and the [**OK**] button to remove the driver.
3. Restart the system to activate the new configuration.

Windows 95/98

Windows 95/98 supports up to **128** serial ports, from **COM1** to **COM128**. To fully integrate the advanced features of Windows 95, multi-process and multi-thread, pure 32-bit Windows 95 virtual device port drivers (VxD) compliant with communication driver (VCOMM) are developed for C218 *Turbo*/PCI and other MOXA multiport boards. The drivers conform to Win32 COMM API standard.

If you are the first time installer or you want to install more boards, please go directly to the section “Installing Driver”.

If you already have installed the driver and want to re-configure the board, please refer to the section “Configuring Board and Port”.

If you want to upgrade or even remove driver, please go to the section “Updating Driver” and section “Removing Driver”.

If you want to remove boards, please simply unplug the undesired boards from the system.

Installing Driver

If you are the first time installer or you want to install more board, this section is for you.

You can easily plug the Intellio C218*Turbo*/PCI board and work right away with little installation effort under Windows 95/98, which supports **Plug and Play** capability. The Windows 95/98 will automatically detect the presence of the newly plugged board and prompt you to install the software driver at the first time. In this case, you need the driver diskette.

Up to four Intellio C218*Turbo*/PCI boards can be installed together as long as the memory address and IRQ number resources are sufficient and available in a system.

The following flow chart illustrates the driver installation stages of the Intellio C218*Turbo*/PCI board. Each stage is detailed later.

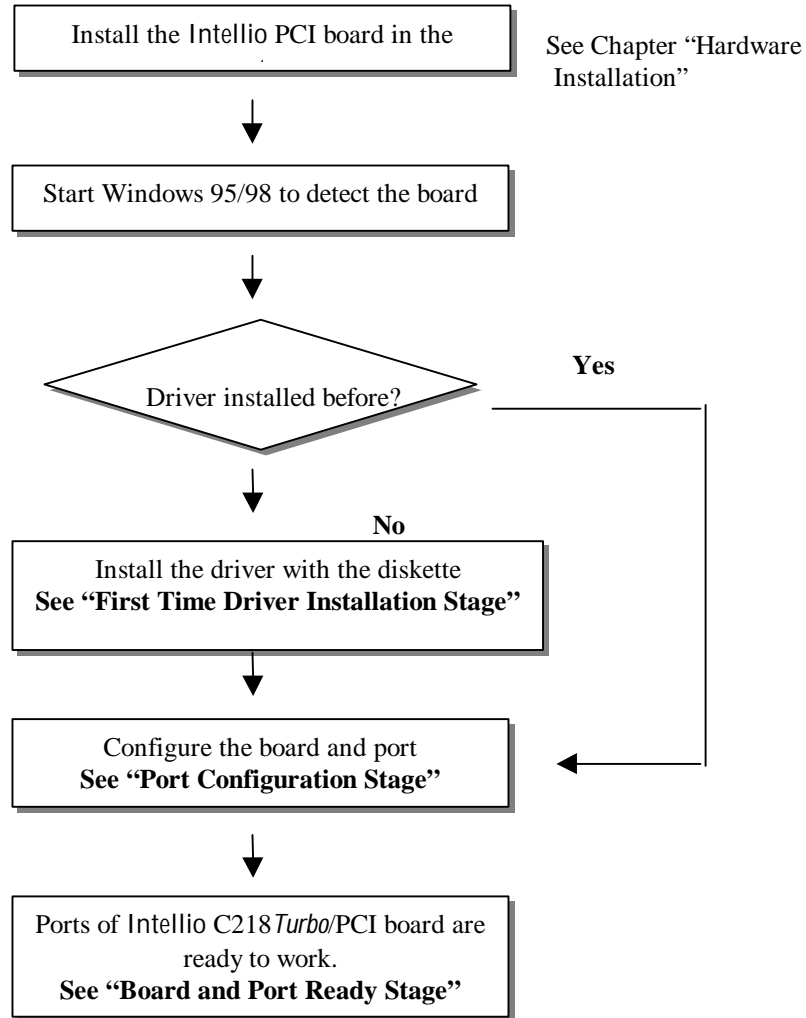

First Time Driver Installation Stage

The stage presents the steps for installing the driver for the first time with the first Intellio C218 Turbo/PCI board. The installation of Intellio C218 Turbo/PCI board for Windows 95 and Windows 98 **differs slightly** and will be described in two columns. **Follow the steps in the left or right column for Windows 95 or 98, respectively.**

1. Upon detecting **the first new Intellio C218 Turbo/PCI board**, Windows 95/98 will automatically show a "New hardware found" message box and then display the following dialog box. Click on the [Next>] button.

Windows 95



Windows 98



2. Click on the [Other Location] button.

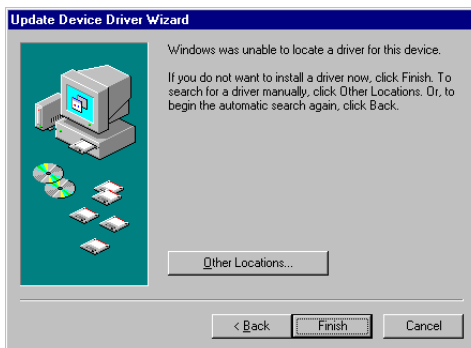

2. Select "Display a list ..." and click [Next>].



3. Type **"A:\Windows.95"** in the Location field, and click **[OK]**. The system will start reading the files from the diskette.

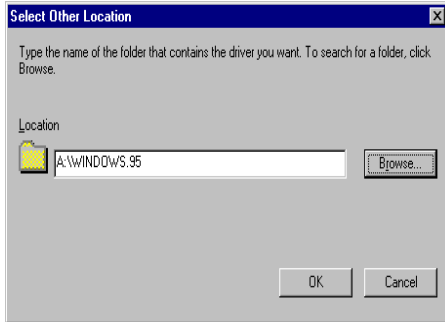

3. Select **"Other Devices"** and click **[Next>]**.



4. Click on the **[Finish]** button.



4. Click on the **[Have Disk]** button.

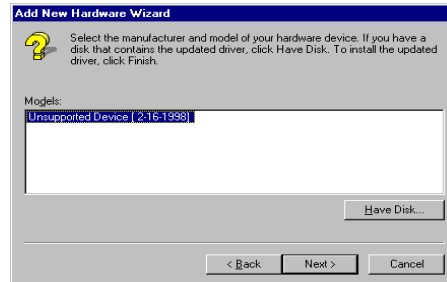

5. Type **"A:\Windows.95"** and click **[OK]**. The system will start reading the files from the diskette.

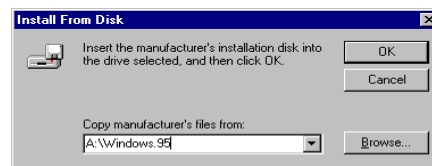

Software Installation

6. Click [Next>].

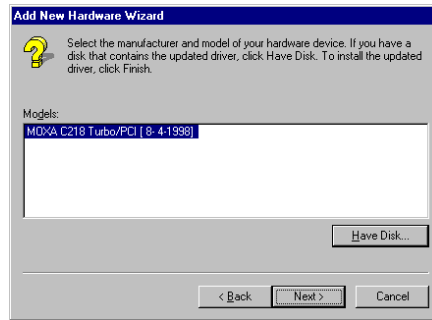

7. Click [Next>].



Port Configuration Stage

This stage displays the “**MOXA Ports Installation**” dialog box for the port configuration. Here you can map the MOXA ports to the system COM numbers.

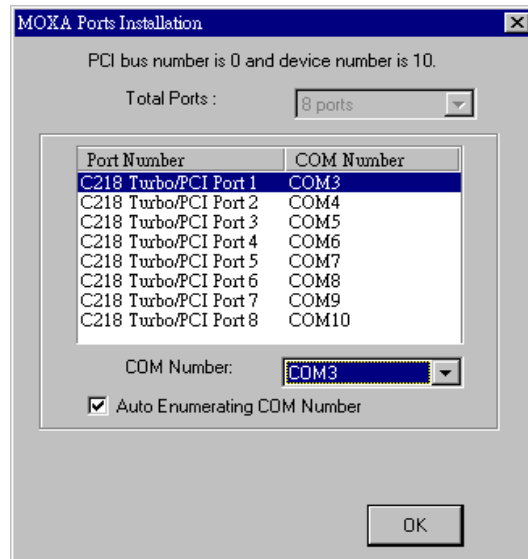

In the “MOXA Ports Installation” dialog box, the “COM Number” field of the newly installed board is **undefined**. You have to map the physical ports to COM numbers in two ways depending on the “**Auto Enumerating COM number**” check box.

- } **Sequential Port Mapping:** (Enable “Auto Enumerating COM number”) Specify the COM number of the first port and subsequent ports are mapped to continuous COM numbers. For instance, if first port is mapped to COM10, then second port is mapped to COM11 sequentially.
- } **Non-sequential Port Mapping:** (Disable “Auto Enumerating COM number”) Specify the COM number for individual port. For instance, the second port can be out of sequence, say COM18, while the first port is mapped to COM10.

Click [OK].

Board and Port Ready Stage

Click on [OK] buttons for all the dialog boxes to finish the configuration and exit the “MOXA Ports Installation” dialog.

In this last stage, you will complete the driver installation.

Windows 95

After the port installation, you can **immediately** use the COM ports of the Intellio C218*Turbo*/PCI board **without restarting the Windows 95 system**.

Windows 98

After the port installation, click on the [Finish] button. Now you can **immediately** use those COM ports of the Intellio C218*Turbo*/PCI board **without restarting the Windows 98 system**.

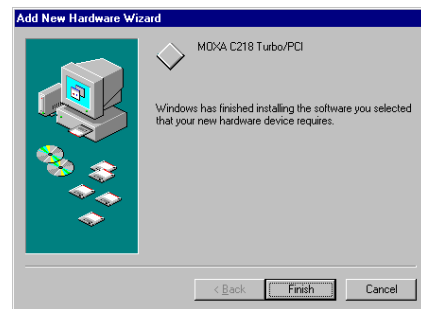

Once the installation is finished, error conditions of the board, **if any**, are displayed on the screen. Otherwise, everything should be fine.

If an error message similar to “C218Turbo/PCI (BusNo=x, DevNo=x) at base memory [XXX] interrupt failure!” appears, consult the “Troubleshooting” chapter.

Note ! Up to now, the driver installation of Intellio C218Turbo/PCI is completed and successful including the board and port configuration. However, if changes of the board and port configuration are needed, please refer to the next section "Configuring the Board and Port" for more configuration details.

Note ! Once the board and driver are installed and the driver restarts successfully, you can start to develop applications by using *PComm* library (See Chapter “Serial Programming Tools”) or using Microsoft Win32 API. Also you can execute any ready-made application such as *PComm* utility Terminal emulator (See Chapter “Serial Programming Tools”) or HyperTerminal to transmit/receive data as well as Remote Access Service to provide dial-up networking capability.

- } If multiple boards are installed at the same time, the same scenario applies for the next boards, except that no driver diskette is asked any more.
- } Similarly, if you want to add more boards and the driver has been installed before, simply plug the Intellio C218Turbo/PCI board and Windows 95/98 will automatically detect and install the required driver.

Configuring Board and Port

If you already have installed the driver and want to re-configure the Intellio C218Turbo/PCI board under Windows 95/98, the following is the procedure for you.

1. Click on the Taskbar [**Start**] button, select the [**Programs**] menu, and then [**MOXA Utilities**] menu and then [**MOXA Configuration Panel**] icon. The configuration panel will be popped up as below.

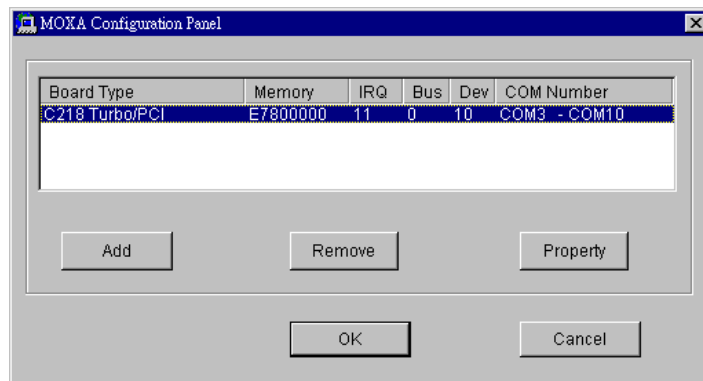

The [**Add**] button and the [**Remove**] button are not applicable in PCI case. A new C218Turbo/PCI board will be automatically found as new hardware and added during the Windows 95/98 startup. To remove a board, simply unplug the undesired C218Turbo/PCI board physically from the system.

2. Click [**Property**] to enter “Property” dialog box to configure the selected board with the correct “**Total Ports**” and “**COM Number**”. Please see **steps 6 to 8** in the previous section, “Installing Driver”, for more details, except that the “Board Type” field is not supposed to be changed.

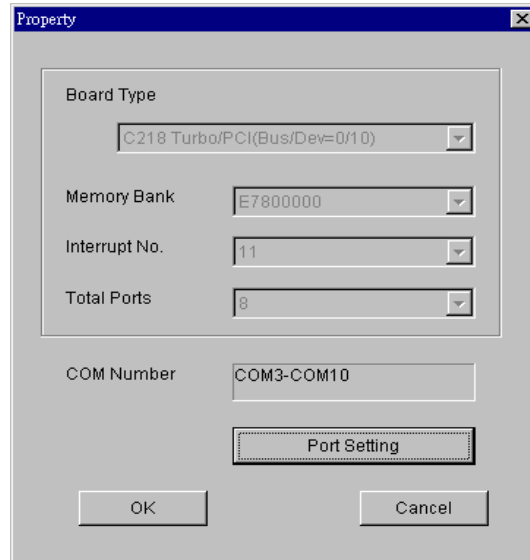

3. In the “Property” dialog, you may click on [Port Setting] button to enter the following “Individual Port Setting” dialog box to change the port COM number mappings or do the advanced settings..

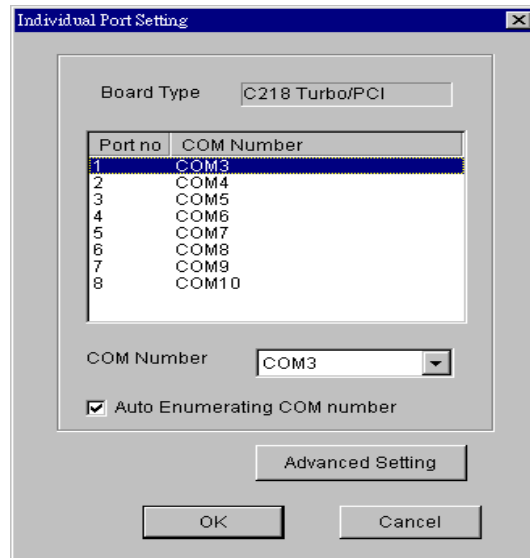

In the “Individual Port Setting” dialog box, you may have two ways to map the physical ports to COM numbers depending on the “**Auto Enumerating COM number**” check box.

- } **Sequential Port Mapping:** (Enable “Auto Enumerating COM number”) Specify the COM number of the first port and subsequent ports are mapped to continuous COM numbers. For instance, if first port is mapped to COM10, then second port is mapped to COM11 sequentially.
- } **Non-sequential Port Mapping:** (Disable “Auto Enumerating COM number”) Specify the COM number for individual port. For instance, the second port can be out of sequence, say COM18, while the first port is mapped to COM10.

In the “Individual Port Setting” dialog box, you may click on [**Advanced Settings**] button to tune the advanced features, “**UART FIFO**” and “**Transmission Mode**”, for each port for particular performance requirements.

Note ! You may skip the following settings and go directly to the next **step 4**, if you do not require any particular performance tuning for the driver.

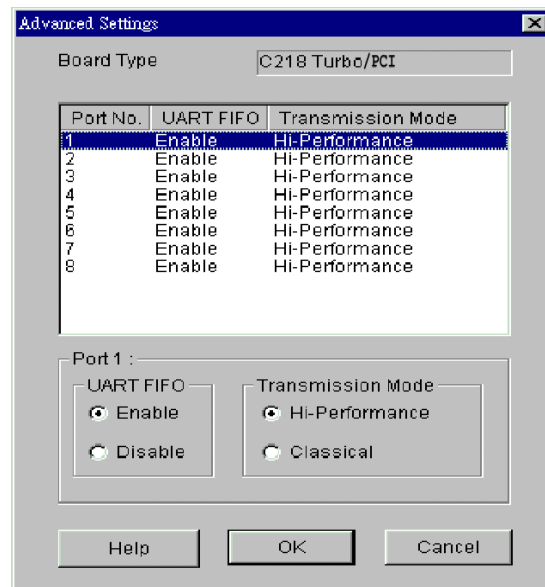

In the “Advanced Settings” dialog box, you may customize the driver with the following two features:

} **UART FIFO**

Enable: You can set this feature to “Enable” (default) and gain best performance for the board.

Disable: You can set this feature to "Disable" to avoid from data loss when communicating with communication devices using S/W flow control.

} **Transmission Mode**

Hi-PerformanceMode: This feature is set to “Hi-Performance” by default, which accelerates the reaction of data writing behavior by utilizing buffering technology. It lets your communication software reach maximum data throughput in large data transmission.

Classical Mode: It lets MOXA ports behave like generic COM ports. Transmission for small data packets would be more precisely and reliable.

4. Click on [OK] buttons for all the dialogs to finish the configuration and exit the MOXA Configuration Panel”.

5. **Restart Windows 95/98 system if you have changed any settings.**

Note! The latest configuration will not take effect unless the system restarts.

Updating driver

Open the [Control Panel] and click on the [System] button, and select the [Device Manager] tab. Select the “Moxa Intellio Multiport Board” entry and the “Moxa C218Turbo/PCI” entry. Click on the [Properties] button and select the [Driver] tab and then click on the [Update Driver...] button.

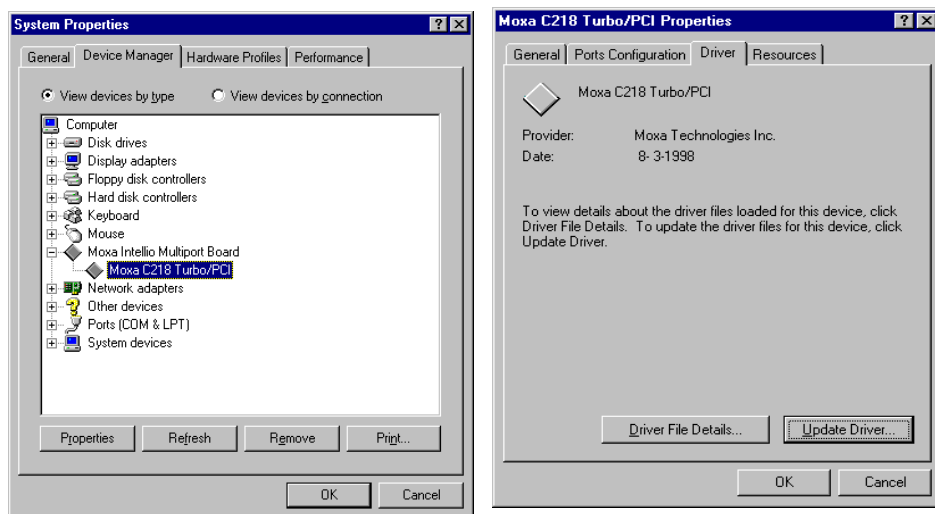

Removing driver

You can not actually remove the driver. You can only remove all the configured boards simply by unplugging all the boards from the system.

Once the MOXA driver is installed, it exists permanently in Windows 95/98 like other adapters do. Removing changes nothing but that particular board's existence in Windows 95/98 Registry.

UNIX

There are various UNIX operating systems, such as SCO UNIX, UNIX SVR4.2, XENIX and Solaris, etc. Different types of UNIX drivers are required for different UNIX. Moxa supports device drivers currently for **SCO UNIX, UNIX SVR4.2 and XENIX.**

In this section, driver installation procedure is described. Administration utility, **mxadm**, is explained, which is for configuration, monitor and terminal emulation. Related issues such as device naming, baud rate settings and terminal enable are stated.

If you are interested in UNIX serial programming, extended Ioctl() commands are provided in Chapter “Serial Programming Tools” for advanced programming. UNIX-specific troubleshooting is included in Chapter “Troubleshooting”.

Installing Driver

Up to four boards of combination of Intellio C218*Turbo*/PCI and C218*Turbo* can be installed together as long as memory resources are sufficient and available in a system.

Step 1. Boot the system and login from the console as a super user (root).

Step 2. Insert driver diskette into a 1.44MB floppy drive, A: or B:.

If the driver files are obtained from the MOXA **FTP** service, put them under the **/tmp/moxa** directory and **skip to the step 5.**

Step 3. Change to root directory by entering the following command:
cd /

Step 4. Enter the following command to extract the installation script file first.
tar xvf /dev/fd0135ds18 /tmp/moxa/mxinstall (if 1.44MB A:)

Step 5. # /tmp/moxa/mxinstall
Follow the instructions prompted to finish the driver installation

Software Installation

MOXA UNIX Device Driver Installation Ver.x.x
Please select one of the following OS:

1. SCO UNIX
2. UNIX SVR4.2
3. XENIX

Select:

Please type 1 for SCO UNIX 3.2.x, SCO OpenServer or SCO Open Desktop. Type 2 for UNIX SVR4.2, UnixWare or MITUX. Type 3 for XENIX.

Please select one of the devices where the driver diskette/files put:

- | | |
|--------------------|-------------|
| 1. /dev/fd0135ds18 | (A: 1.44MB) |
| 2. /dev/fd096ds15 | (A: 1.2 MB) |
| 3. /dev/fd1135ds18 | (B: 1.44MB) |
| 4. /dev/fd196ds15 | (B: 1.2 MB) |
| 5. Hard Disk | /tmp/moxa |

Select:

Please type 1, 2, 3, 4 or 5.

Step 6. Then the **MOXA Multiport Board Installation Utility** dialog will show for driver installation. When finished, press any key to continue.

For SCO UNIX or SCO OpenServer or XENIX

Then you will be prompted to rebuild kernel at this moment and you are recommended to do so unless you need to install other driver. Please type “y”. After kernel rebuild, please shutdown the system on your own.

For UNIX SVR4.2 or UnixWare or MITUX

Then you will be prompted to shutdown the system on your own for kernel rebuilding and you are recommended to do so.

Step 7. Once the system reboots, run “**mxadm**” to configure the board and port settings.

Select and open “**Basic Configuration**” to do the basic board and port configuration. You may further optionally select and open “**Advanced Configuration**” to do the advanced settings.

Select and open “**Board Reset**” to reset the driver and board for the latest configuration to take effect.

For more details, see later section “**Administration Utility -mxadm**”.

Up to now, you have already completed the whole installation and the Intellio C218Turbo/PCI board is ready to work.

Note! *Please **double check** if all the Intellio C218Turbo/PCI components: Control Board, link cable and external modules, are connected and fastened tightly in order to ensure the system and driver will start successfully later.*

Now you can run any ready-made applications such as getty terminal or PPP/SLIP. Also you can start to develop applications by using **Standard UNIX library with MOXA extended UNIX Ioctl() Commands.** (See Chapter “**Serial Programming Tools**”.)

MOXA TTY Device Naming Convention

If the Intellio C218 *Turbo*/PCI is successfully configured, there will be two tty devices created for each port at `/dev` directory: one is **non-MODEM tty** (e.g. `ttya11`), and the other is **MODEM tty** (e.g. `ttyA11`). The two devices are actually accessing the same physical port except that the MODEM tty has to check the ON status of DCD signal to be able to open device, and closing device automatically as DCD signal is OFF.

The convention of the MOXA tty device name is `/dev/tty{a-d}{1}{1-8}`, where:

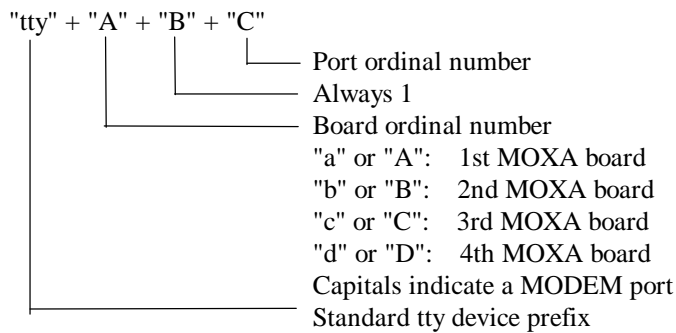

For example:

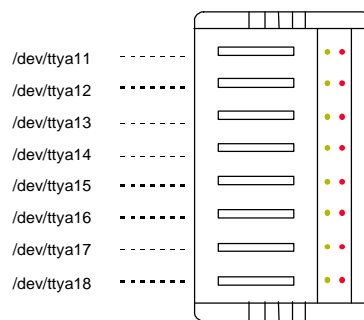

Opt8A

Administration Utility - mxadm

You can use the administration utility, **mxadm**, to change the Intellio C218Turbo/PCI **basic and advanced configuration**, to **reset the board**, to **tune performance** and to **remove the installed MOXA driver** from the UNIX system, which are detailed as follows. For the details of the rest utilities: **port monitoring, and terminal emulator**, please refer to Section "UNIX" of Chapter "Serial Programming Tools".

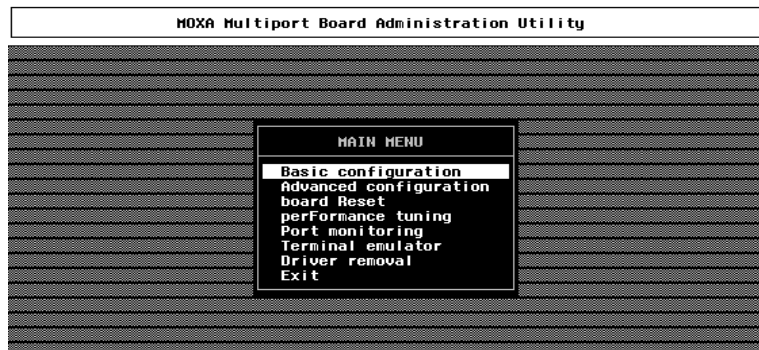

Basic Configuration

This utility is to configure basic settings for the driver.

1. In the "Basic Configuration" dialog box, you can press Enter in each field to select the desired option. Select "C218Turbo/PCI" in the "Board Type" field.

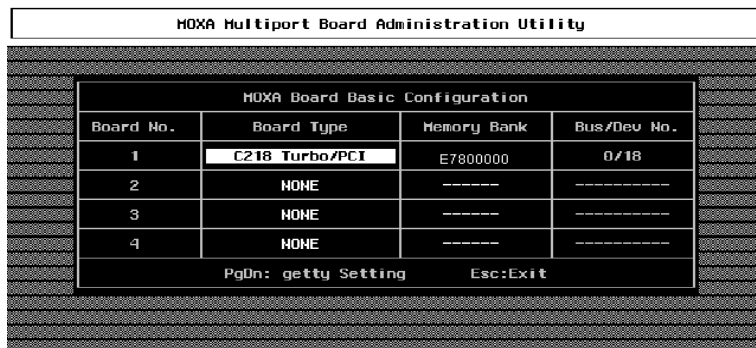

Software Installation

In the “Basic Configuration” dialog, you should first press Enter in board type field to select board type, **C218Turbo/PCI**. And then a list of Intellio C218*Turbo/PCI* boards found available is popped up for you to select. Normally, one choice is available if there is one Intellio C218*Turbo/PCI* board installed beforehand.

Press Enter on the desired entry of the list to select. Now the selected Intellio C218*Turbo/PCI* board is configured with BIOS assigned memory address and Bus/Device numbers as shown.

2. Press Page Down to enter “**getty Setting**” sub-dialog, there are some noticeable fields for initialize the port for getty usage. You may skip this step if you will not use getty utility.

MOXA Multiport Board Administration Utility					
getty Setting					
Board	Board No.	Device Name	non-MODEM	MODEM	ev No.
1	1	ttga11/A11	m		k
	1	ttga12/A12	m		k
	1	ttga13/A13	m		k
2	1	ttga14/A14	m		k
	1	ttga15/A15	m		k
3	1	ttga16/A16	m		k
	1	ttga17/A17	m		k
4	1	ttga18/A18	m		k
PgUp,PgDn:More Ports Enter:Select Esc:Exit					

Non-Modem and Modem Baud Rate

This field stands for the initial baud rate symbol and hunt sequence for Non-Modem /Modem tty. It is simply for setting parameters of getty entries in system file /etc/inittab which could also be manually modified by system administrator. Its value comes from the UNIX system “getty default” file, i.e., “/etc/gettydefs”. Modify this field to suit your need.

In some cases, you may need to modify the “getty default” file as well. For example, in some UNIX systems, the “9600” symbol indicated 8-data-bit no-parity while in others it may stand for 7-data-bit, even-parity. So, please examine the “getty default” file carefully, and make sure the terminal settings is the same. Otherwise, garbled data will be inevitable.

Advanced Configuration

This is to provide advanced settings for advanced driver features beyond basic settings described in the previous **Basic Configuration**. Similarly, in “Board Settings” dialog, **board reset** (described later) is available for the latest configuration to take effect without kernel rebuilding and system reboot.

1. In the “Advanced Board Configuration” dialog, you can press Enter in each field to select the desired option. The fields are details as follows.

MORA Multiport Board Administration Utility			
MORA Board Advanced Configuration			
Board No.	Board Type	OnBoard LineDiscipline	Baudrate Mapping
1	C218 Turbo/PCI	Enable	High Band
2	NONE	-----	-----
3	NONE	-----	-----
4	NONE	-----	-----

F1:Help PgDn:Port Feature Settings Esc:Exit

On Board Line Discipline

Advanced feature is set to “**Enable**” by default, which means all the tty line discipline jobs, e.g. translating NL to CR, will be done on the Intellio C218 *Turbo/PCI* board (Terminal mode), instead of doing them on host. This will reduce the host workload significantly. If it is set to “**Disable**”, the tty line discipline will either be done on host (Terminal mode) or be not done at all (Transparent mode). Please refer to “Feature” field in the “Advanced Port Settings” dialog on next page.

Baud Rate Mapping

This advanced feature is set to “**High Band**” by default, indicating that the baud rate 50, **B50**, will no longer stand for 50 bps. Instead, **B50** means 57600 bps, **B75** is for 115.2 Kbps, **B110** is for 230.4 Kbps, and **B134** is for 460.8 Kbps, and **B150** is for 921.6 Kbps. You may press F1 Help for on-line details.

If this feature is set to “**Low Band**”, the original definition of UNIX baud rate mapping are used.

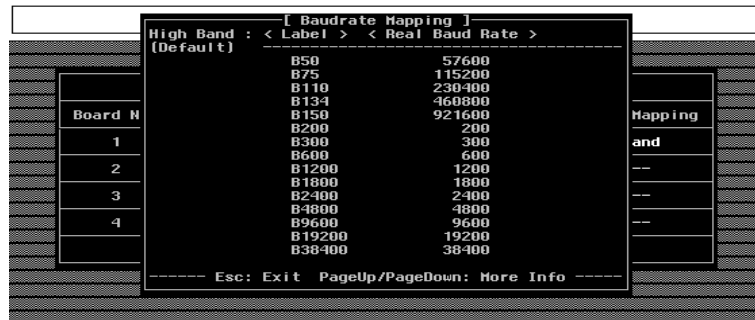

2. Press PageDown to enter “Advanced Port Settings” sub-dialog, there are some noticeable fields for initialize the ports for advanced usage. You may skip this step if you do not concern these features.

MOXA Multiport Board Administration Utility					
MOXA Board Advanced Port Settings					
Board No.	Device Name	Feature	Response	UART FIFO	BTS/CTS flowctrl
1	ttya11/A11	Terminal	Slow	Enable	Disable
1	ttya12/A12	Terminal	Slow	Enable	Disable
1	ttya13/A13	Terminal	Slow	Enable	Disable
1	ttya14/A14	Terminal	Slow	Enable	Disable
1	ttya15/A15	Terminal	Slow	Enable	Disable
1	ttya16/A16	Terminal	Slow	Enable	Disable
1	ttya17/A17	Terminal	Slow	Enable	Disable
1	ttya18/A18	Terminal	Slow	Enable	Disable

PgUp,PgDn:More Ports Esc:Exit

Feature

In “Port Feature Settings” sub-dialog, port feature [Terminal] is the only choice if On Board Line Discipline is set to “Enable”. This is good for terminal application users.

However, if On-Board Line Discipline is set to “Disable”, port feature could be either [Transparent] or [Terminal]. In case of [Terminal], all the tty line discipline jobs will be done on host which surely is a burden to the host. In case of [Transparent], no time-consuming tty line discipline is applied for the port except flow control, thus non-terminal applications such as data acquisition will benefit from it, e.g. gain better throughput and performance. The Intellio C218 Turbo/PCI firmware will do Xon/Xoff flow control and H/W flow control if ixon/ixany or ixoff are set via ioctl() system call. In this case, the Non-Modem and Modem Baud Rate do not apply.

Response

Three levels, Slow, Normal and Fast, of port response time are designed for user's need. Ports with faster response time will consume more host CPU's resource while slower response consumes less resource. The response time for those ports with normal or slow response can be further tuned by the response level in "Performance Tuning" menu. In addition, if the port feature is set to On-board Line Discipline "Disable" and Feature "Terminal", response option will be locked at "Slow" level.

UART FIFO

You can set this feature to "**Enable**" (default) and gain most performance for the board. Or you can set this feature to "**Disable**" to avoid from data loss when communicating with plain communication devices using S/W flow control.

RTS/CTS Hardware Flow Control

This feature is for more flexible driver behavior. If set to "**Disable**" (default), CTS signal is not needed for tty port to transfer data and RTS/CTS hardware flow control function in driver is disabled. On the contrary, if set to "**Enable**", CTS signal is needed for tty port to transfer data and RTS/CTS hardware flow control function in driver is enabled.

Performance Tuning

The utility let you tune the favored response time for those ports with Resp = Norm or Slow in [Port Feature] sub-menu of Advanced configuration. Ten response time levels (0-9) are available for tuning. The idea is that the faster response time will consume more host CPU resource while slower response consume less resource. If the host CPU is fast enough or a quick response is highly demanded, choose level 9 would be suitable.

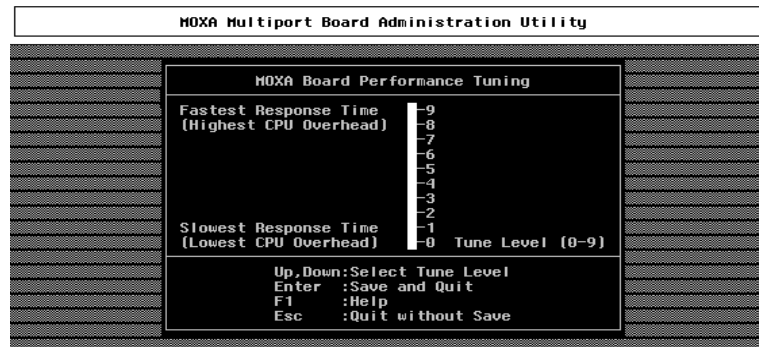

Board Reset

The board reset utility eliminates the need to shut down the UNIX system to re-initialize the Intellio C218Turbo/PCI board with new configuration. Press Enter to start board reset.



However, before the board reset is issued, you must make sure that

1. All enabled ports must be disabled.
2. All processes related to the Intellio C218*Turbo*/PCI, including `getty` or `tty` monitor, are killed.

Once the board is reset, the following message may show if it is successful.

```
MOXA Serial I/O Board (Verx.x)
Downloading
MOXA-C218Turbo/PCI (MemBank=XX000;BusNo=X;DevNo=X) is found.
```

If one of the following message appears, please see Chapter "Troubleshooting".

```
WARNING! C218Turbo/PCI (MemBank=XX000;BusNo=X;DevNo=X) not found!
Or ERROR! C218Turbo/PCI (MemBank=XX000) download failed!
```

Driver Removal

If you want to remove the Intellio C218*Turbo*/PCI device driver and return to your previous system configuration, simply press Enter in this function entry and answer “**Y**” to confirm. Then the system will be rebuild. This may take some time. If you answer “**N**”, no action will be taken.

Checking Board Initialization Status

When the system starts up and enters into the multiuser mode, you should see the board initialization status report, which is same as one of the messages described in the “Board Reset” part of previous section.

Setting MOXA Ports to Terminal

Following procedure is how to set the MOXA port to the “Terminal” for login purpose, taking ttya11 as an example,

SCO UNIX/OpenServer/Open Desktop/XENIX

```
# enable /dev/ttya11
```

UNIX SVR4.2 and UnixWare

1. Edit (e.g. use vi editor) the file /etc/inittab.
2. Modify the tty entry from "ma11:23:off:/etc/getty ttya11 9600" to "ma11:23:respawn:/etc/getty ttya11 9600".
3. # init q

Or refer to your UNIX system manuals for how to activate a tty port.

Serial Programming Tools

Moxa supports powerful but easy serial programming library and utilities under Windows NT, Windows 95/98 and UNIX. You will greatly save the developing time with the MOXA Serial Programming Tools. The following sections will details the installation, the library and the utilities for various O.S. platforms.

Windows NT and Windows 95/98

PComm, the professional serial comm tool for PC, is a software package under **Windows NT and Windows 95/98**, which consists of powerful serial communication library for easy programming in most popular languages, useful utilities such as diagnostic, monitor and terminal emulator, illustrative example programs and comprehensive on-line documents.

The serial communication library is useful for developing a system for data communication, remote access, data acquisition or industrial control in the Windows NT and Windows 95/98 environment, which offers an easier solution compared with the more complex Windows Win32 COMM API.

Installation

To install *PComm*, please run `\Setup.exe` in the diskette. Note that *PComm* diagnostic and monitor utilities are for MOXA boards only. MOXA Windows NT or Windows 95/98 device driver as well as MOXA board are required. The driver are installed separately and detailed in Chapter “Software Installation”.

***PComm* Programming Library**

The serial communication library is to assist users to develop programs for serial communications **for any COM port** complying with Microsoft Win32 API. It can ease the implementation of multi-process and multi-thread serial communication programs and hence greatly reduce the developing time.

For complete library function description and example programs for Visual C++, Visual Basic and Delphi, please see help file and example programs in ***PComm*** directory for more details.

Utilities

The followings are short descriptions of each utility. For details, please see on-line help in the diskette.

Diagnostic (for MOXA boards only)

A convenient diagnostic program provides internal and external testing, such as IRQ, Tx/D/RxD, UART, CTS/RTS, DTR/DSR, DTR/DCD testing, etc., for the MOXA boards and ports to verify correct operation of both the software and hardware.

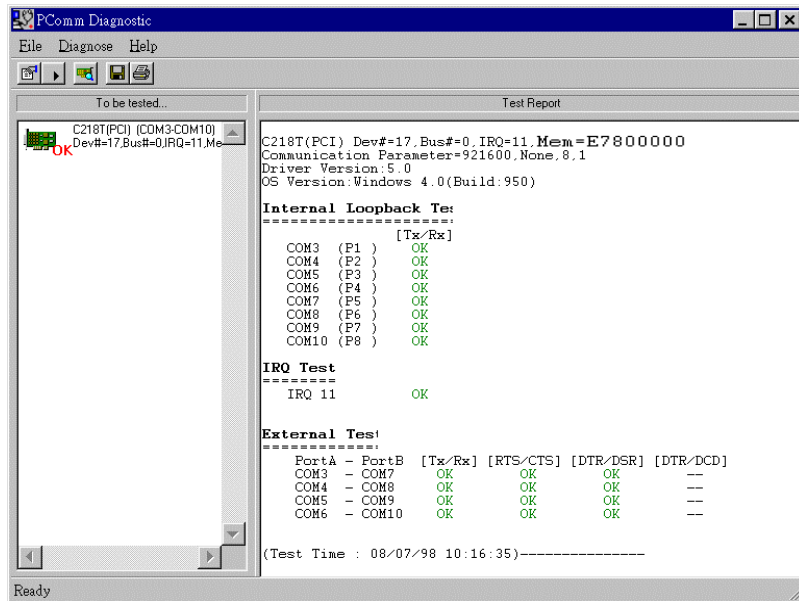

Monitor (for MOXA boards under Windows NT Only)

A useful port status monitoring program allows you to watch the selected MOXA COM ports' data transmitting/receiving throughput and communication line status which are updated and displayed on the screen at every time interval. In addition, you may click on one of the specific displayed port in order to see the current communication parameters and status of that port.

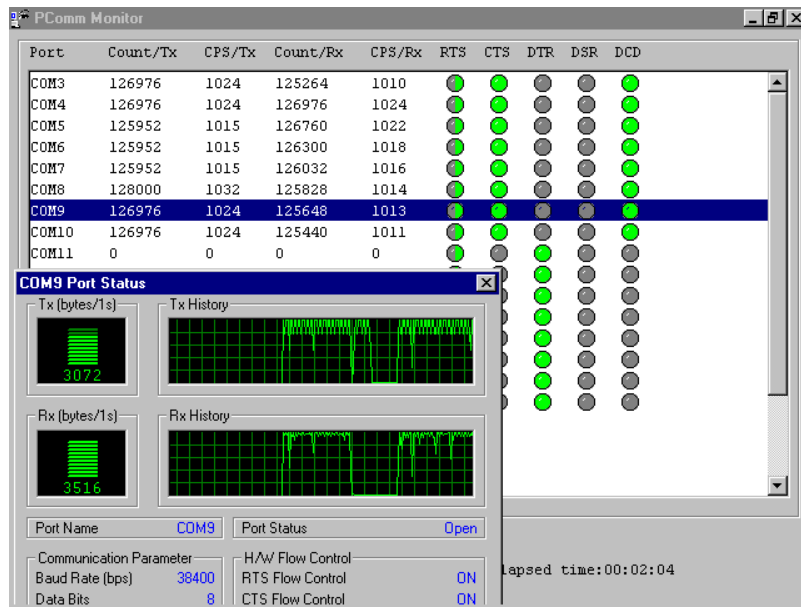

Terminal Emulator

The Terminal Emulator features multi-windows and supports terminal types of VT100 and ANSI. You can transfer data interactively, send pattern periodically or transfer file using ASCII, XMODEM, YMODEM, ZMODEM and KERMIT protocols.

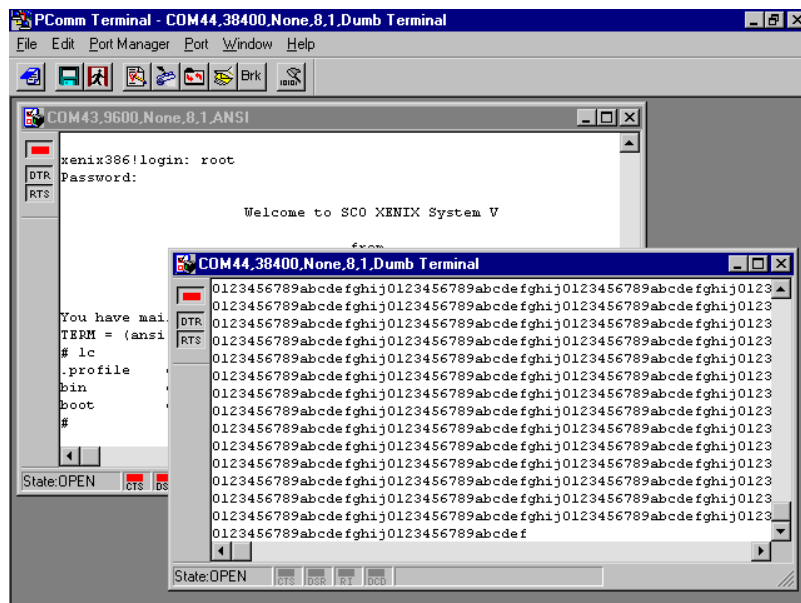

UNIX

Programming the MOXA Ports

The system calls that apply to standard tty port can also be applied to MOXA port since MOXA port conforms to UNIX tty standard. System calls are like `open()`, `ioctl()`, `read()`, `write()`, `close()`, etc. Please refer to your UNIX Programmer's Reference manual.

However, these system services only provide limited functions and thus may not satisfy the sophisticated programmers' need. In order to meet the user's special purpose, MOXA supports extended services through `ioctl()` command, which are:

1. `MIBUFED` (= 0x401) To get byte count in input buffer.
2. `MOBUFED` (= 0x402) To get byte count in output buffer.
3. `MTCRTS` (= 0x403) To control RTS output signal.
4. `MTCSTR` (= 0x404) To control DTR output signal.
5. `MLOWATER` (= 0x405) To set output buffer low water level.
6. `MSTATUS` (= 0x407) To read modem line status (CTS/DSR/DCD).
7. `MHWFLOW` (= 0x40e) To enable/disable the hardware flow control.

The next section details all the commands.

Extended UNIX `ioctl()` Commands

The following lists the syntax of MOXA extended functions for both non-SVR4.x and SVR4.x UNIX. The variable `moxa_fd` is the returned file descriptor by `open()` a specific MOXA port. For example,

```
int moxa_fd;  
moxa_fd = open("/dev/ttya11",O_RDWR);
```

1. MIBUFED

This function let you know how many bytes queued in input buffer when this function is issued.

Syntax for SCO UNIX/XENIX

```
#define MIBUFED      0x401
int    count; /* number of bytes queued in the buffer */

ioctl(moxa_fd, MIBUFED, &count);
```

Syntax for UNIX SVR4

```
#include          <sys/stropts.h>
#include          <sys/sysmacros.h>
#define MIBUFED      0x401
struct strioclt    ioc;
int    count; /* number of bytes queued in the buffer */

ioc.ic_cmd = MIBUFED;
ioc.ic_timeout = 0;
ioc.ic_len = sizeof(int);
ioc.ic_dp = (char *)&count;
ioctl(moxa_fd, I_STR, &ioc);
```

Note: Due to the characteristics of STREAMS driver, the returned count of bytes buffered only reflect the data buffered on MOXA board, not including the data buffered in STREAMS queue. In this case, the count is for reference only. For example, returned count may always be zero, but there still are data buffered in STREAMS queue.

2. MOBUFED

This function let you know the byte count queued in output buffer when this function is issued.

Syntax for SCO UNIX/XENIX

```
#define MOBUFED      0x402
int    count; /* number of bytes queued in the output buffer */

ioctl(moxa_fd, MOBUFED, &count);
```

Syntax for UNIX SVR4

```
#include          <sys/stropts.h>
#include          <sys/sysmacros.h>
#define MOBUFED      0x402
struct strioclt    ioc;
int    count; /* number of bytes queued in the output buffer */
```

```
ioc.ic_cmd = MOBUFED;
ioc.ic_timeout = 0;
ioc.ic_len = sizeof(int);
ioc.ic_dp = (char *)&count;
ioctl(moxa_fd, I_STR, &ioc);
```

Note: See MIBUFED for influence of STREAMS driver.

3. MTCRTS

This function, only valid when hardware flow control is turned off (see MHWFLOW), is used to drive RTS signal on or off.

Syntax for SCO UNIX/XENIX

```
#define MTCRTS          0x403
#define TurnON          1
#define TurnOFF         0

ioctl(moxa_fd, MTCRTS, TurnON);
ioctl(moxa_fd, MTCRTS, TurnOFF);
```

Syntax for UNIX SVR4

```
#include <sys/stropts.h>
#include <sys/sysmacros.h>
#define MTCRTS          0x403
#define TurnON          1
#define TurnOFF         0
struct strioctl
int                    setting;

setting = TurnON /* or TurnOFF */;
ioc.ic_cmd = MTCRTS;
ioc.ic_timeout = 0;
ioc.ic_len = sizeof(int);
ioc.ic_dp = (char *)&setting;
ioctl(moxa_fd, I_STR, &ioc);
```

4. MTCDTR

This function, only valid when hardware flow control is turned off (see MHWFLOW), is used to drive DTR signal on or off.

Syntax for SCO UNIX/XENIX

```
#define MTCDDTR      0x404
#define TurnON      1
#define TurnOFF     0

ioctl(moxa_fd, MTCDDTR, TurnON);
ioctl(moxa_fd, MTCDDTR, TurnOFF);
```

Syntax for UNIX SVR4

```
#include <sys/stropts.h>
#include <sys/sysmacros.h>
#define MTCDDTR      0x404
#define TurnON      1
#define TurnOFF     0
struct stioctl
int                setting;

setting = TurnON /* or TurnOFF */;
ioc.ic_cmd = MTCDDTR;
ioc.ic_timeout = 0;
ioc.ic_len = sizeof(int);
ioc.ic_dp = (char *)&setting;
ioctl(moxa_fd, I_STR, &ioc);
```

5. MLOWATER

Sometimes the application software may not be able to write any further data to the output buffer because of the output buffer being full. The application has to wait until the output buffer has 'enough space' again. The criteria to tell if the output buffer has 'enough space' is whether the output buffer reached its 'low water' level. That is the output buffer will accept further data only when the 'low water' level is reached.

If the 'low water' value is relatively small, you may find that the output buffer become empty before you write another block of data (this is quite possible because UNIX is time-sharing multitasking environment). This will result in discontinuous data transmission. In a timeout-sensitive application, e.g. facsimile (FAX) transmission, discontinuous data may falter the operation.

The default 'low water' is 512 bytes. You can enlarge it but better not exceed one half of the output buffer. Each port's output buffer is 8K bytes.

Syntax for SCO UNIX/XENIX

```
#define MLOWATER          0x405
int lowater; /* low water value of output buffer (default = 512 bytes) */
ioctl(moxa_fd, MLOWATER, lowater);
```

Syntax for UNIX SVR4

```
#include <sys/stropts.h>
#include <sys/sysmacros.h>
#define MLOWATER          0x405
struct strioclt          ioc;
int lowater; /* low water value of output buffer (default = 512 bytes) */

ioc.ic_cmd = MLOWATER;
ioc.ic_timeout = 0;
ioc.ic_len = sizeof(int);
ioc.ic_dp = (char *)&lowater;
ioctl(moxa_fd, I_STR, &ioc);
```

6. MSTATUS

This function is used to know the RS-232 line status (CTS/DSR/DCD).

Syntax for SCO UNIX/XENIX

```
#define MSTATUS 0x407
int status; /* status = RS-232 line status */
/* bit0» CTS (1:on, 0:off) */
/* bit1» DSR (1:on, 0:off) */
/* bit2» DCD (1:on, 0:off) */

ioctl(moxa_fd, MSTATUS, &status);
```

Syntax for UNIX SVR4

```
#define MSTATUS          0x407
#include <sys/stropts.h>
#include <sys/sysmacros.h>

struct strioclt          ioc;
int status; /* status = RS-232 line status */
/* bit0» CTS (1:on, 0:off) */
/* bit1» DSR (1:on, 0:off) */
/* bit2» DCD (1:on, 0:off) */

ioc.ic_cmd = MSTATUS;
ioc.ic_timeout = 0;
ioc.ic_len = sizeof(int);
ioc.ic_dp = (char *)&status;
ioctl(moxa_fd, I_STR, &ioc);
```

7. MHWFLOW

This function is used to enable/disable hardware flow control. The first `open()` function of a port will set the hardware flow control bits on or off depending on the **[RTS/CTS Hardware Flow Control]** configuration in `mxadm`. However, users might want to control the DTR or RTS signal on their will, thus the RTS flow control bit should be turned off (`HWFlowControlOff`) in order to take over the control of DTR or RTS signal via function `MTCRTS` or `MTCDTR`. `MTCRTS` and `MTCDTR` can be effective only after the RTS flow control bit of `MHWFLOW` is turned off.

Syntax for SCO UNIX/XENIX

```
#define MHWFLOW          x40e
#define HWFlowControlOff 0x00
#define CTSFlowControlBitOn 0x01
#define RTSFlowControlBitOn 0x02
#define HWFlowControlOn  0x03

ioctl(moxa_fd, MHWFLOW, CTSFlowControlBitOn);
ioctl(moxa_fd, MHWFLOW, RTSFlowControlBitOn);
ioctl(moxa_fd, MHWFLOW, CTSFlowControlBitOn | RTSFlowControlBitOn);
```

Syntax for UNIX SVR4

```
#include <sys/stropts.h>
#include <sys/sysmacros.h>

#define MHWFLOW          0x40e
#define HWFlowControlOff 0x00
#define CTSFlowControlBitOn 0x01
#define RTSFlowControlBitOn 0x02
#define HWFlowControlOn  0x03
struct strioctl ioc;
int
setting = CTSFlowControlbitOn;
ioc.ic_cmd = MHWFLOW;
ioc.ic_timout = 0;
ioc.ic_len = sizeof(int);
ioc.ic_dp = (char *)&setting;
ioctl(moxa_fd, I_STR, &ioc);
```

Utilities

You can use the administration utility, **mxadm**, to **monitor port activity** and to do **terminal emulation**, which are details as follows.

Port Monitoring

This utility gives you a quick view about all the MOXA ports' activities. You can easily learn each port's total received/transmitted (Rx/Tx) character count since the time when the monitoring is started. Rx/Tx throughputs per second are also reported in interval basis (e.g. the last 5 seconds) and in average basis (since the time the monitoring is started). You can reset all ports' count by <HOME> key. <+> <-> (plus/minus) keys to change the displaying time interval.

MOXA Multiport Board Administration Utility						
Time[00:00:46] Board #1 Type:C218 Turbo/PCI Interval 3 sec <+/->						
Device name	Char Count (bytes)	Rx		Tx		
		Throughput (BPS) Interval	Average	Char Count (bytes) Interval	Throughput (BPS) Average	
ttua11/A11	907776	21760	20172	929457	22335	20521
ttua12/A12	908032	21760	20178	880289	22335	19739
ttua13/A13	914944	23978	20332	924051	22303	20534
ttua14/A14	914688	23978	20326	922289	22181	20495
ttua15/A15	908288	21760	20184	927333	22565	20607
ttua16/A16	908032	21760	20178	888068	22282	19734
ttua17/A17	914944	23978	20332	921153	21919	20470
ttua18/A18	907776	21760	20172	924483	22618	20544

PgUp,PgDn:More Ports Home:Reset Count Esc:Exit Enter:Port Status

Press Enter on the port, that cursor stay, to view the port's communication parameters, signal status, and input/output queue.

Serial Programming Tools

MOXA Multiport Board Administration Utility					
Time[00:01:25]		Board #1 Type:C218 Turbo/PCI		Interval 3 sec <+/->	
Device name	Char Cou (bytes)	Port Status		Tx Throughput(BPS)	
		Device Name	ttya11/A11	Interval	Average
ttya11/A11	17520	Baud Rate	110	13901	20560
ttya12/A12	17523	Parity	None	21924	20418
ttya13/A13	17525	Data Bits	8	33162	20844
ttya14/A14	17589	Stop Bits	1	32783	20826
ttya15/A15	17525	CTS	ON	21919	20853
ttya16/A16	17523	DSR	ON	22340	20429
ttya17/A17	17592	DCD	ON	22677	20854
ttya18/A18	17520	Input Queue	6251	13895	20564
		Output Queue	22975		
PgUp,PgDn:None Port			PgDn:Next PgUp:Prev		Enter:Port Status
			Esc:Exit		

Terminal Emulator

This utility provides data sending and receiving ability of all tty ports, especially for MOXA ports. It is quite useful for testing simple application, for example, sending AT command to a modem connected to the port or used as a terminal for login purpose. Note that this is only a dumb terminal emulation without handling full screen operation. Besides, data scope function with pattern/file transfer is provided.

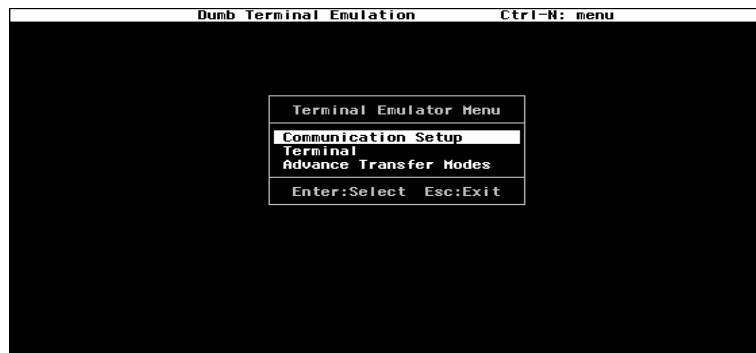

1. Select and Press Enter on item “**Communication Setup**” to setup up all the communication parameters for connection.

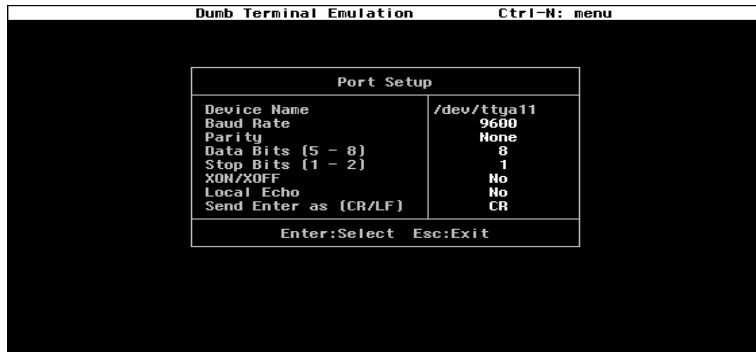

- 2 Select and enter **“Terminal”** to enter terminal emulation. Or select and enter **“Advanced Transfer Modes”** to perform pattern or file transfer with protocols such as ZModem.

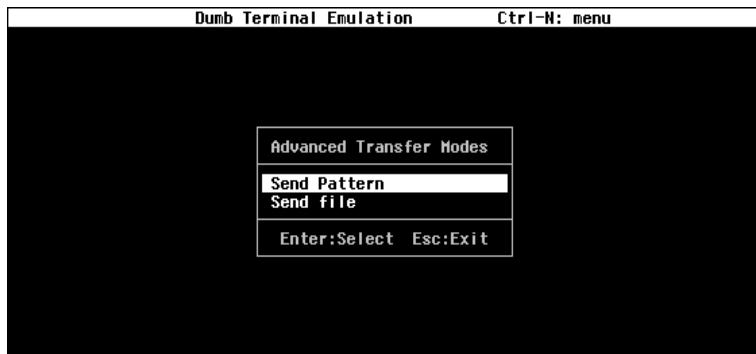

RS-485 Programming for Opt8J

If you intend to do RS-485 communication with Opt8J, please follow the RS-485 programming guide below and also refer to Chapter “**Connection Option (Opt8x) and Cable Wiring**” for more Opt8J RS-485 operation details.

The Opt8J supports **only 2-wire half-duplex RS-485 communication**. Data+/- pins are served for both data transmitting and receiving, depending on the RTS signal.

The port switch of each port should be set to **On** position. The port is for transmitting data if **RTS is asserted** and for receiving data if **RTS is not asserted**.

RTS scheme is suitable for any system, including Windows NT and Windows 95/98, DOS, or UNIX, that permits RTS control from application programs.

How to transmit and receive data under Windows NT and Windows 95/98

We recommend you to configure Intellio C218*Turbo*/PCI ports as follows in order to acquire precise timing control in RS-485 2-wire transmission.

First set the “Transmission Mode” in the configuration program to “Classical”. UART FIFO status has no effect under the circumstance.

There are 2 solutions to control RS-485 2-wire transmission.

Solution 1

The following model is common in RS-485 2-wire transmission.

```
sio_SetWriteTimeouts(port, 0); /* Set sio_write() into block mode */
sio_RTS(port, 1); /* Turn on RTS signal. The RS-485
port is ready for transmitting data. */
sio_write(port, buff, 10); /* Write 10 byte characters in "buff".
The function blocks until last
character transmitted */
sio_RTS(port, 0); /* Turn off RTS signal. The RS-485
port is ready for receiving data. */
sio_read(port, buff, 10); /* Read 10 bytes */
```

Solution 2

There's a dedicated RS-485 function in *PComm* library. It integrates the above functions of solution 1 regarding sending data as one.

```
sio_putb_x(port, buff, tick ); /* 1. Turn on RTS and ready for  
transmitting data.  
2. Send data.  
3. Wait for tick time.  
4. Turn off RTS and ready for  
receiving data. */
```

For more information on these functions, please refer to *PComm* library on-line Help file for Windows NT and Windows 95/98.

Connection Option (Opt8x) and Cable Wiring

In serial data communications, the term **DTE** is for Data Terminal Equipment like PC COM1/2, serial printer and terminal. The term **DCE** is for Data Communication Equipment like modem. Please check the precise pinouts, the following pinouts are typical examples.

RS-232 Cable Wiring for Opt8A/B/C/D/S

RS-232 8-port connection boxes/octopus cable designed for Intellio C218*Turbo*/PCI are:

Opt8A: 8-port RS-232 DB25 female connection box

Opt8B: 8-port RS-232 DB25 male connection box

Opt8C: Octopus cable with 8 male RS-232 DB25 ports

Opt8D: Octopus cable with 8 male RS-232 DB9 ports

Opt8S: 8-port RS-232 DB25 surge protected female connection box

The followings are pin assignments for various connection options:

Opt8A/S
(DCE, DB25 Female)

2	RxD
3	TxD
4	CTS
5	RTS
6	DTR
7	GND
8	DCD
20	DSR

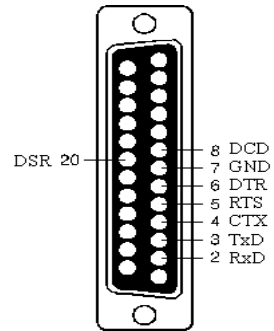

Opt8B/C
(DTE, DB25 Male)

2	TxD
3	RxD
4	RTS
5	CTS
6	DSR
7	GND
8	DCD
20	DTR

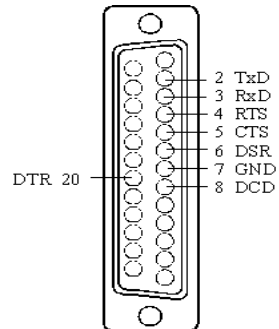

Opt8D
(DTE, DB9 Male)

1	DCD
2	RxD
3	TxD
4	DTR
5	GND
6	DSR
7	RTS
8	CTS

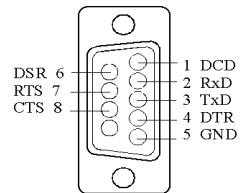

Connection Option (Opt8x) and Cable Wiring

Type 1: To connect Intellio C218Turbo/PCI to a DTE device.

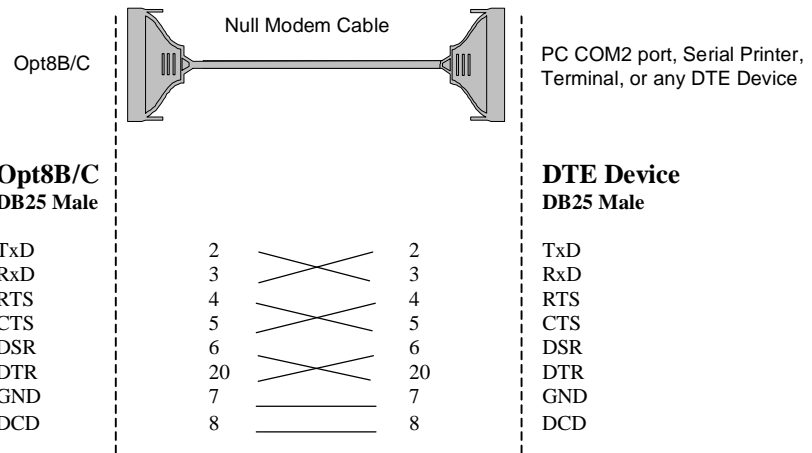
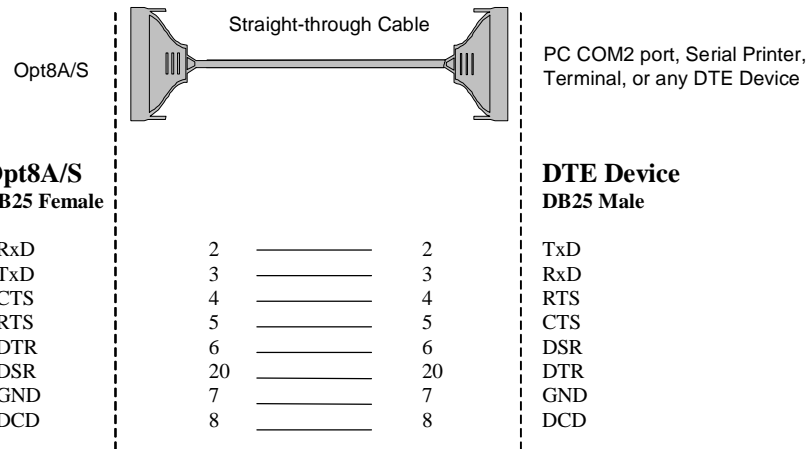

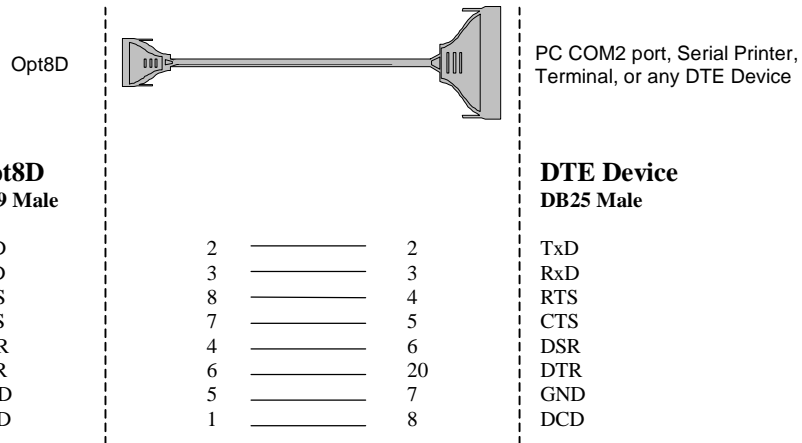

Type 2: To connect Intellio C218Turbo/PCI to a DCE device.

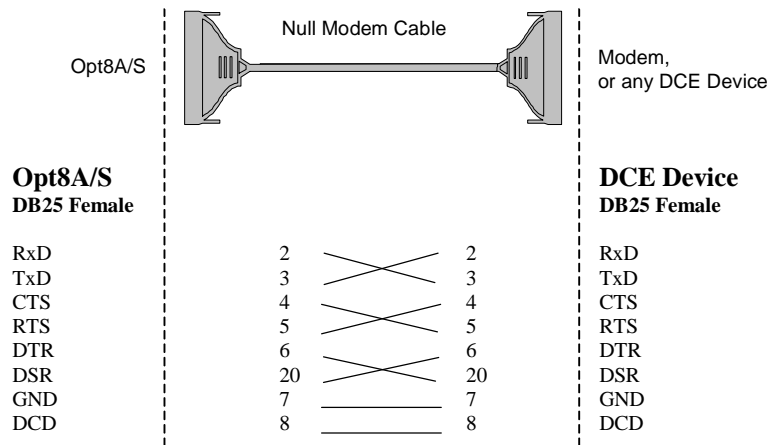

Connection Option (Opt8x) and Cable Wiring

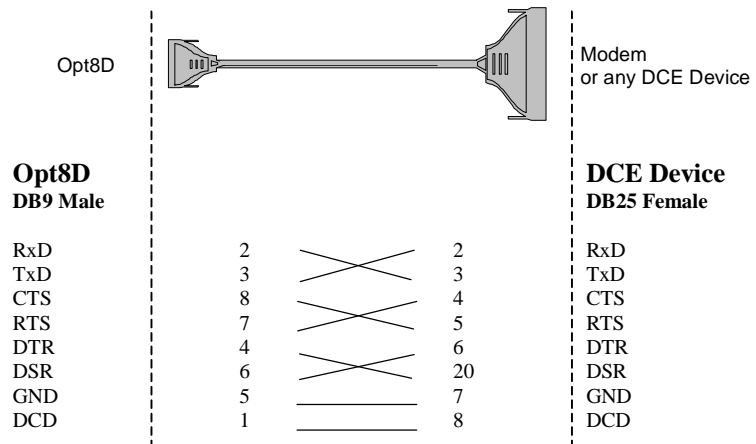
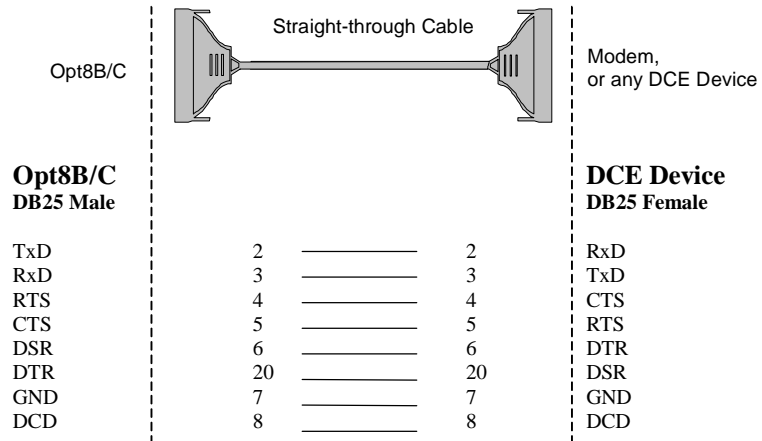

Type 3: To connect Intellio C218Turbo/PCI to a DTE with 3-pin wiring.

If the “**Hardware flow control**” feature is set to “**ON**”, you must loop back (or short) the RTS with CTS and DSR with DTR, DCD on MOXA site, indicated in dash-lines of the following diagrams. If the “**Hardware flow control**” feature is set to “**OFF**”, you could just leave RTS, CTS, DSR, DTR, DCD open, ignoring the connection indicated in dash-lines.

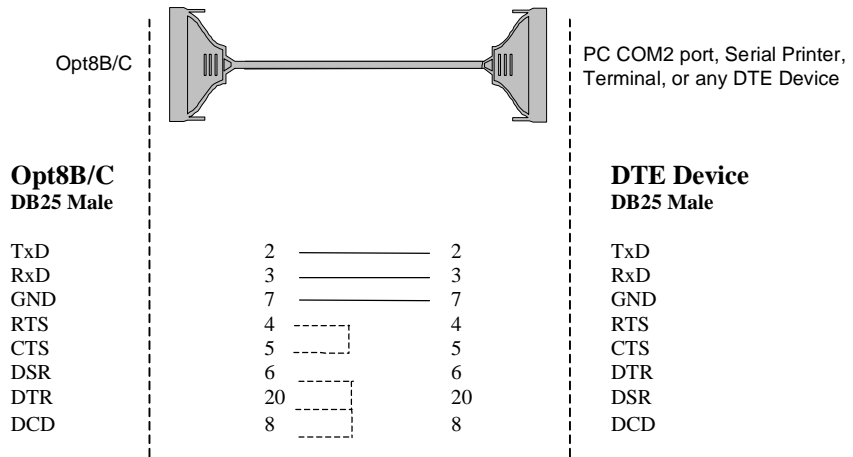
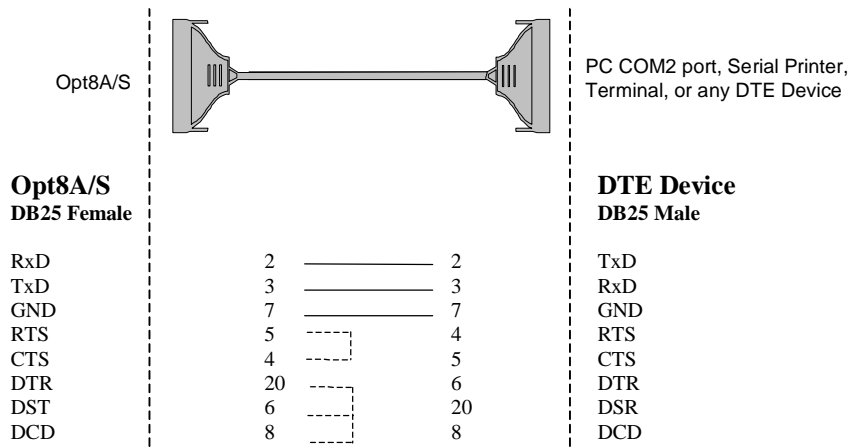

RS-422 Cable Wiring for Opt8J/F/Z

RS-422 connection boxes designed for Intellio C218*Turbo*/PCI are:

- Opt8J:** Connection box with 8 female RS-422/485 DB25 ports. Set the port switch to **OFF** position (RS-422) for the desired port(s).
- Opt8F:** Connection box with 8 female RS-422 DB25 ports and Max. 500V DC isolation protection which prevents damage caused by high potential voltage.
- Opt8Z:** Connection box with 8 female RS-422 DB25 ports but without isolation protection.

RS-422 Pinouts for Opt8J/F/Z:

Opt8J/F/Z

2	RxD+(B)	
3	TxD+(B)	
14	RxD-(A)	
16	TxD-(A)	
7	GND	
4	CTS+(B)	
5	RTS+(B)	
13	RTS-(A)	} Opt8J only
19	CTS-(A)	

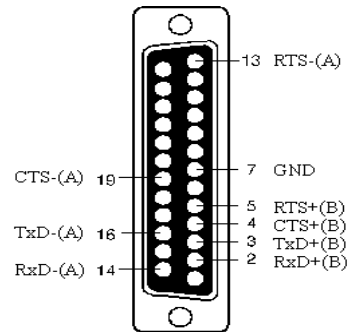

The RS-422 transmission distance can reach as long as 4000ft. The connection box needs an external power adapter to supply 5V DC power. Either 110V or 220V AC power adapter is selectable.

Connection Option (Opt8x) and Cable Wiring

The followings are operation modes for RS-422:

RS-422 Point-to-point

	Opt8F/Z		RS-422 Device
	3 TxD+(B)	———	RxD+(B)
	16 TxD-(A)	———	RxD-(A)
	2 RxD+(B)	———	TxD+(B)
	14 RxD-(A)	———	TxD-(A)
	7 GND	———	GND

RS-422 Broadcasting

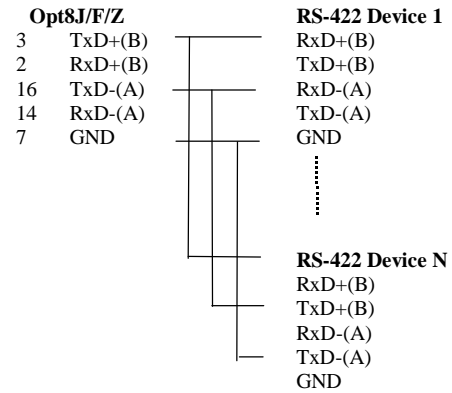

Opt8J RS-422 with Handshaking

	Opt8J		RS-422 Device
	3 TxD+(B)	———	RxD+(B)
	16 TxD-(A)	———	RxD-(A)
	2 RxD+(B)	———	TxD+(B)
	14 RxD-(A)	———	TxD-(A)
	7 GND	———	GND
	5 RTS+(B)	———	CTS+(B)
	13 RTS-(A)	———	CTS-(A)
	4 CTS+(B)	———	RTS+(B)
	19 CTS-(A)	———	RTS-(A)

RS-485 Cable Wiring for Opt8J

One RS-485 connection box designed for Intellio C218Turbo/PCI is:

Opt8J: Connection box with 8 female RS-422/485 DB25 ports. Set the port switch to **ON** position.

The Opt8J supports **only 2-wire half-duplex RS-485 communication**. **Data+/-** pins are served for both data transmitting and receiving, depending on the RTS signal.

RS-485 Pinouts for Opt8J:

Opt8J	
3	Data+(B)
7	GND
16	Data-(A)

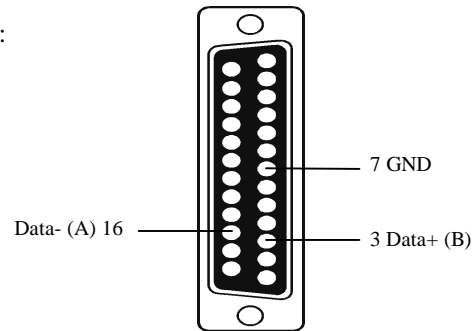

Multidrop RS-485 Half-duplex

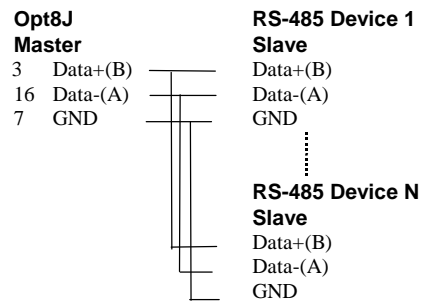

Point-to-Point RS-485 Half-duplex

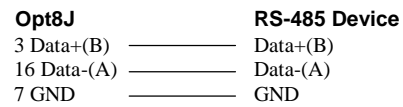

See Section “**RS-485 Programming**” of Chapter “**Serial Programming Tools**” for more Opt8J RS-485 programming details.

Connection Option (Opt8x) and Cable Wiring

RS-422/485 Impedance Matching

For RS-422/485 serial communications, when an electrical signal travels through two different resistance junctions in a transmission line, the impedance mismatch will sometimes cause signal reflection. Signal reflection causes signal distortion, which in turn will contribute communication errors. The solution to this problem is to establish the same impedance at the line ends as in the line itself by terminating them with resistors.

The value of the termination resistor should equal the characteristic impedance of the transmission line. The resistors should be added **near the receiving side**.

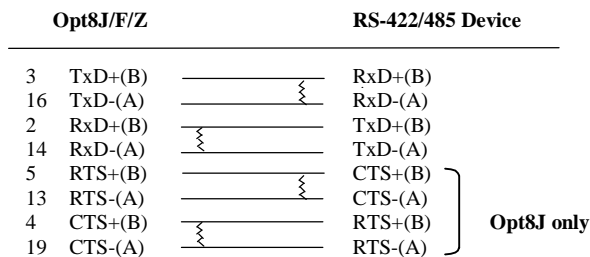

Note:

1. ξ Stands for termination resistor near the receiving side
2. The suggested termination resistor for AWG #26 cable is 100 ohm.
3. The suggested termination resistor for phone cable is 600 ohm.

6

Troubleshooting

Common C218 *Turbo*/PCI problems and possible solutions are listed below, in addition to those operating systems specific ones. If you still have problems, contact your dealer or Moxa for help. Or report it using “**Problem Report Form**” at the end of this manual to your dealer at once for faster technical support.

General Troubleshooting

1. **MOXA PCI board can not be detected by the MOXA driver while installing the driver.**

Hardware causes and solutions:

- a. The board is not installed or missing (absent). Please install it.
- b. The board is not properly plugged in the system. If that is the case, then re-install the board and make sure that it fits well in a 32-bit PCI slot this time. Sometimes the slot for plugging board is bad. In this case, please try other slots until a good one is found.
- c. Your mother board does not have vacant IRQ for the Intellio C218*Turbo*/PCI. Please enter BIOS and make sure there are available IRQ in PCI/PnP setting..

2. **MOXA board and driver activated but can not transfer (transmitting/receiving) data.**

Hardware Causes and Solutions:

- a. Check if wrong cable wiring. Refer to Chapter “Connection Options (Opt8x) and Cable Wiring” for precise pinouts of the connector type you are using.
- b. Cable, external box or board is defective. You may use other port, cable or box or board to verify. In addition, *PComm* Utility “Diagnostics” for Windows NT and Windows 95/98 is good for testing MOXA board and port condition. If the

report of diagnostics shows error, replace the error component.

Software Causes and Solutions:

- a. Intellio C218 *Turbo* Series will check line status (CTS) before it sends data out if RTS/CTS flow control feature is set to “Enable” in configuration or application program. Please see Chapter “Connection Options (Opt8x) and Cable Wiring” for proper wiring. Check the line status of the suspected port using the diagnostic LED indicators on the mini tester.
- b. Perhaps the application controlling the board is not correctly written according to the corresponding API of the operating system. To verify, please run existing and known good application or Moxa provided utility. For example, under Windows NT and Windows 95/98, *PComm* Utility “Terminal emulator” or “HyperTerminal” is good for testing COM ports. Under UNIX, “Terminal emulator” in the MOXA administration utility “mxadm” and “stty”, “cat”, or “getty” are existed programs for testing tty port.

Windows NT

This section is specific for troubleshooting under Windows NT. For general problems and solutions, please see previous Section “General Troubleshooting”.

1. **After system reboot, error message “MOXA C218 Turbo/PCI Multiport Board #1 addr [XXX]: IRQ test failure!” appears in Event Log.**

This indicates MOXA board is found but the IRQ is conflicting with other adapter. Please make sure there is no conflict with other adapter's IRQ. Check the PCI BIOS IRQ setting first. Make sure IRQ is available.

2. **After system starts, error message “MOXA C218 Turbo/PCI Multiport Board #1 addr [XXX] not found!” appears in the Event Log.**

Shutdown the system first and refer to the problem 1 for solutions in the previous section, “General Troubleshooting”.

3. Windows NT system panic (blue screen).

The possible reason is IRQ or memory conflict with other ISA Bus adapters like LAN and SCSI board or system BIOS. Please refer to the corresponding problem in previous Section "General Troubleshooting" for solutions.

- 4. Error Message: C218tnt.cod file not found!**
Error Message: C218tnt.cod file length is wrong!
Error Message: C218tnt.cod file data content error!

It means something is wrong with driver installation or the file has been deleted accidentally or corrupted somehow. To recover the file, simply install the driver again.

Windows 95/98

This section is specific for troubleshooting under Windows 95/98. For general problems and solutions, please see previous Section "General Troubleshooting".

- 1. Error Message "MOXA C218Turbo/PCI (BusNo=xx, DevNo=xx) at base memory [XXX] interrupt failure!" appears.**

This indicates MOXA board is found but the IRQ is conflicting with other adapter. Make sure there is no conflict with other adapter's IRQ. Check the PCI BIOS IRQ setting and make sure IRQ is available.

- 2. Error Message: C218tnt.cod file not found!**
Error Message: C218tnt.cod file length is wrong!
Error Message: C218tnt.cod file data content error!

It means something is wrong with driver installation or the file has been deleted accidentally or corrupted somehow. To recover the file, simply install the driver again.

UNIX

This section is specific for troubleshooting under UNIX. For general problems and solutions, please see previous Section "General Troubleshooting".

1. **During system reboot, error message “WARNING! C218 Turbo/PCI (XX000;BusNo=X;DevNo=X) not found!” appears.**

The possible cause is memory conflict or defective board. Please shutdown the system first, and then refer to the corresponding problem and solutions in previous Section “General Troubleshooting”.

2. **During system reboot, error message “ERROR! C218 Turbo/PCI (MemBank=XX000) download failed!” appears.**

The possible cause is memory conflict or defective board. Please shutdown the system first, and then refer to the corresponding problem and solutions in previous Section “General Troubleshooting”.

3. **MOXA port responds too slowly or abnormal key operation.**

The applications are not compatible with the C218 *Turbo/PCI* On-board line discipline. The only way to work it around is to set On-board line discipline feature to “Disable” in [Board] sub-menu of Advanced configuration (Section “UNIX” of Chapter “Software Installation”).

4. **When respawning quite a few number of tty ports, the following error messages appear: “Time out table overflow”, “File table overflow”, “Region table overflow”.**

The above error messages imply that the system resources are exhausted. You should tune the kernel parameters to a larger value and rebuild the kernel to be able to accommodate the new configuration. Refer to UNIX system manual about how to tune the parameters and rebuild kernel.

“Time out table overflow”: NCALL parameter too small.

“File table overflow”: NFILE or NINODE parameter too small.

“Region table overflow”: NREGION or NPROC parameter too small.

5. The newly rebuilt kernel could not boot.

The C218 *Turbo*/PCI driver might not be built into the new kernel correctly.

- a. Please use the last good kernel backup to boot again. The kernel backup in SCO UNIX is **/unix.moxa** while in UNIX SVR4.2 **/stand/unix.moxa**.
- b. Then remove the C218 *Turbo*/PCI driver. Refer to Section “UNIX” of Chapter “Software Installation” for driver removal.
- c. Re-install the C218 *Turbo*/PCI driver once more.

6. When using MOXA port for PPP/SLIP connection, what should the “On Board Line Discipline” feature be set to?

Set to “Disable”. Otherwise the PPP/SLIP connection will fail.

Appendix

Technical Reference

Specifications

% Bus interface:	32-bit PCI (PCI Spec. 2.1 compliance)
% Number of ports:	8
% Max. boards:	4
% Base memory addr.:	Assigned by PCI BIOS (Maps to 16K Bytes system RAM)
% IRQ:	Assigned by PCI BIOS (2, 3, 4, 5, 7, 10, 11, 12, 15)
% RISC processor:	TI TMS320BC203
% On-board buffer:	512 KB dual-ported RAM
% Comm. controller:	16C550C or Compatible» Ⓢ
% Speed (bps):	50 ~ 921.6K(Maximum speed may be limited by certain connection option such as Opt8J 460.8K bps)
% Data bits:	5, 6, 7, 8
% Stop bits:	1, 1.5, 2
% Parity:	none, even, odd, space, mark
% Data signals:	RS-232» ⓈxD, RxD, RTS, CTS, DTR, DSR, DCD, GND RS-422» ⓈxD+/-, RxD+/-, GND (Opt8J: RTS+/-, CTS+/-) RS-485» ⓈData+/-, GND
% Connectors:	8» ⓈB25/DB9 male/female (DTE/DCE)
% Surge protection:	max. 2000V (Opt8S)
% Operating temp:	0 ~ 55 ¼[
% Power requirement:	190mA (+5V), 110mA (+12V), 160mA (-12V)
% Dimensions:	180mm» Ⓢmm» Ⓢmm
% Operating Systems:	See the driver support list below.

C218 *Turbo*/PCI

Windows NT	D
Windows 95/98	D
SCO UNIX/OpenServer	D
UNIX SVR4.2	D
XENIX	D

D : Driver supported by Moxa and shipped with product

Note : Download the newest drivers from the MOXA FTP service

PCI

The 32-bit Intellio C218 *Turbo*/PCI board complies with PCI Spec. 2.1. Hardware configuration for IRQ and Memory addresses is automatically assigned by PCI BIOS. Hence, it is a must to **have the board plugged first** before installing software driver.

Unlike ISA slots, different PCI slots in the same PC may have different bus numbers and device numbers with respect to PCI specifications. The same PCI board will have different system configurations if switched to a different PCI slot, which may be called **slot-sensitive** or **slot-dependent**. This may also apply to PCI slots in PC of different mother board, which may use **different device number set**. For example, some use 17, 18, 19, and 20 for identifying the respective PCI slot but some use 11, 12, 13 and 14.

Due to the **slot-dependency**, it is necessary to **re-configure the software driver** once the board is plugged in different PCI slots.

Up to four boards of Intellio C218 *Turbo*/PCI are allowed in a system. When installing multiple boards, **please do keep in mind the order you plug the boards** for distinguishing the boards installed.

Dual-Ported RAM

There is 512 KB of dual-ported DRAM on the Intellio C218 *Turbo*/PCI, which is used as a data buffer and memory map device for the mother board. It is called "dual-ported" because it is accessed by both mother board CPU and the Intellio C218 *Turbo*/PCI on-board CPU. Generally speaking, the memory access time is much

faster than normal I/O access.

All messages and data are transferred through this 512 KB dual-ported memory. The buffer area appears as normal 16-bit memory to the PC AT I/O channel.

Every Intellio C218 *Turbo*/PCI only occupies 16 KB of memory space (window) from the system point of view.

UART 16C550C

The UART chip, **16C550C**, is an intelligent asynchronous controller capable of supporting one full duplex channel that transfers data at **921.6 Kbps** simultaneously. To increase the overall data throughput, special features such as on-chip FIFO and on-chip hardware flow control are used to reduce the number of interrupts to the on board CPU and to prevent any loss of valuable data.

DB62 Connector Pinouts

The following lists the pin assignments of the DB62 connector on the bracket. You may fabricate octopus cable for DB25 to 8 x DB9.

Pin no.	Signal	Pin no.	Signal	Pin no.	Signal
1	TxD1	22	RxD1	43	CTS1
2	DTR1	23	DSR1	44	RTS1
		24	DCD1	45	GND
3	RxD2	25	TxD2	46	CTS2
4	DSR2	26	DTR2	47	RTS2
5	DCD2				
6	TxD3	27	RxD3	48	CTS3
7	DTR3	28	DSR3	49	RTS3
		29	DCD3	50	GND
8	RxD4	30	TxD4	51	CTS4
9	DSR4	31	DTR4	52	RTS4
10	DCD4	32	GND		
11	RxD5	33	TxD5	53	CTS5
12	DSR5	34	DTR5	54	RTS5
13	DCD5			55	GND
14	TxD6	35	RxD6	56	CTS6
15	DTR6	36	DSR6	57	RTS6
		37	DCD6	58	GND
16	RxD7	38	TxD7	59	CTS7
17	DSR7	39	DTR7	60	RTS7
18	DCD7	40	GND		
19	RxD8	41	TxD8	61	CTS8
20	DSR8	42	DTR8	62	RTS8
21	DCD8				

Return Procedure

For product repair, exchange or refund, you must:

- % Provide evidence of original purchase
- % Fill out the Problem Report Form (PRF) as detailed as possible for shorter product repair time.
- % Obtain a Return Merchandise Authorization (RMA) number from the sales representative or dealer
- % Carefully pack the product in anti-static package, and send it, pre-paid, to the dealer. The RMA number should show on the outside of the package, and include a description of the problem along with the return address and telephone number of a technical contact.