

**MVME3100**  
**Single-Board Computer**

**Installation and Use**

**V3100A/IH1**

January 2006 Edition

© Copyright 2006 Motorola Inc.

All rights reserved.

Printed in the United States of America.

Motorola and the stylized M logo are trademarks of Motorola, Inc., registered in the U.S. Patent and Trademark Office.

All other product or service names mentioned in this document are the property of their respective owners.

## Safety Summary

The following general safety precautions must be observed during all phases of operation, service, and repair of this equipment. Failure to comply with these precautions or with specific warnings elsewhere in this manual could result in personal injury or damage to the equipment.

The safety precautions listed below represent warnings of certain dangers of which Motorola is aware. You, as the user of the product, should follow these warnings and all other safety precautions necessary for the safe operation of the equipment in your operating environment.

### **Ground the Instrument.**

To minimize shock hazard, the equipment chassis and enclosure must be connected to an electrical ground. If the equipment is supplied with a three-conductor AC power cable, the power cable must be plugged into an approved three-contact electrical outlet, with the grounding wire (green/yellow) reliably connected to an electrical ground (safety ground) at the power outlet. The power jack and mating plug of the power cable meet International Electrotechnical Commission (IEC) safety standards and local electrical regulatory codes.

### **Do Not Operate in an Explosive Atmosphere.**

Do not operate the equipment in any explosive atmosphere such as in the presence of flammable gases or fumes. Operation of any electrical equipment in such an environment could result in an explosion and cause injury or damage.

### **Keep Away From Live Circuits Inside the Equipment.**

Operating personnel must not remove equipment covers. Only Factory Authorized Service Personnel or other qualified service personnel may remove equipment covers for internal subassembly or component replacement or any internal adjustment. Service personnel should not replace components with power cable connected. Under certain conditions, dangerous voltages may exist even with the power cable removed. To avoid injuries, such personnel should always disconnect power and discharge circuits before touching components.

### **Use Caution When Exposing or Handling a CRT.**

Breakage of a Cathode-Ray Tube (CRT) causes a high-velocity scattering of glass fragments (implosion). To prevent CRT implosion, do not handle the CRT and avoid rough handling or jarring of the equipment. Handling of a CRT should be done only by qualified service personnel using approved safety mask and gloves.

### **Do Not Substitute Parts or Modify Equipment.**

Do not install substitute parts or perform any unauthorized modification of the equipment. Contact your local Motorola representative for service and repair to ensure that all safety features are maintained.

### **Observe Warnings in Manual.**

Warnings, such as the example below, precede potentially dangerous procedures throughout this manual. Instructions contained in the warnings must be followed. You should also employ all other safety precautions which you deem necessary for the operation of the equipment in your operating environment.



To prevent serious injury or death from dangerous voltages, use extreme caution when handling, testing, and adjusting this equipment and its components.

## Flammability

All Motorola PWBs (printed wiring boards) are manufactured with a flammability rating of 94V-0 by UL-recognized manufacturers.

## EMI Caution



This equipment generates, uses and can radiate electromagnetic energy. It may cause or be susceptible to electromagnetic interference (EMI) if not installed and used with adequate EMI protection.

## Lithium Battery Caution

This product contains a lithium battery to power the clock and calendar circuitry.



Danger of explosion if battery is replaced incorrectly. Replace battery only with the same or equivalent type recommended by the equipment manufacturer. Dispose of used batteries according to the manufacturer's instructions.



Il y a danger d'explosion s'il y a remplacement incorrect de la batterie. Remplacer uniquement avec une batterie du même type ou d'un type équivalent recommandé par le constructeur. Mettre au rebut les batteries usagées conformément aux instructions du fabricant.



Explosionsgefahr bei unsachgemäßem Austausch der Batterie. Ersatz nur durch denselben oder einen vom Hersteller empfohlenen Typ. Entsorgung gebrauchter Batterien nach Angaben des Herstellers.

## CE Notice (European Community)



This is a Class A product. In a domestic environment, this product may cause radio interference, in which case the user may be required to take adequate measures.

Motorola products with the CE marking comply with the EMC Directive (89/336/EEC). Compliance with this directive implies conformity to the following European Norms:

EN55022 “Limits and Methods of Measurement of Radio Interference Characteristics of Information Technology Equipment”; this product tested to Equipment Class A

EN55024 “Information technology equipment—Immunity characteristics—Limits and methods of measurement”

Board products are tested in a representative system to show compliance with the above mentioned requirements. A proper installation in a CE-marked system will maintain the required EMC performance.

In accordance with European Community directives, a “Declaration of Conformity” has been made and is available on request. Please contact your sales representative.

## **Notice**

While reasonable efforts have been made to assure the accuracy of this document, Motorola, Inc. assumes no liability resulting from any omissions in this document, or from the use of the information obtained therein. Motorola reserves the right to revise this document and to make changes from time to time in the content hereof without obligation of Motorola to notify any person of such revision or changes.

Electronic versions of this material may be read online, downloaded for personal use, or referenced in another document as a URL to the Motorola Web site. The text itself may not be published commercially in print or electronic form, edited, translated, or otherwise altered without the permission of Motorola, Inc.

It is possible that this publication may contain reference to or information about Motorola products (machines and programs), programming, or services that are not available in your country. Such references or information must not be construed to mean that Motorola intends to announce such Motorola products, programming, or services in your country.

## **Limited and Restricted Rights Legend**

If the documentation contained herein is supplied, directly or indirectly, to the U.S. Government, the following notice shall apply unless otherwise agreed to in writing by Motorola, Inc.

Use, duplication, or disclosure by the Government is subject to restrictions as set forth in subparagraph (b)(3) of the Rights in Technical Data clause at DFARS 252.227-7013 (Nov. 1995) and of the Rights in Noncommercial Computer Software and Documentation clause at DFARS 252.227-7014 (Jun. 1995).

Motorola, Inc.  
Embedded Communications Computing  
2900 South Diablo Way  
Tempe, Arizona 85282

# Contents

---

<b>About This Manual</b> .....	<b>xv</b>
Overview of Contents .....	xv
Comments and Suggestions .....	xvi
Conventions Used in This Manual .....	xvi
<b>1 Hardware Preparation and Installation</b> .....	<b>1</b>
Introduction .....	1
Description .....	1
Getting Started .....	1
Overview of Startup Procedures .....	2
Unpacking Guidelines .....	2
Hardware Configuration .....	3
MVME3100 Layout .....	3
Configuration Switch (S4) .....	5
Geographical Address Switch (S3) .....	6
PMC I/O Voltage Configuration .....	7
RTM SEEPROM Address Switch (S1) .....	7
Hardware Installation .....	8
Installing the MVME3100 into a Chassis .....	8
Connection to Peripherals .....	9
Completing the Installation .....	10
<b>2 Startup and Operation</b> .....	<b>11</b>
Introduction .....	11
Applying Power .....	11
Switches and Indicators .....	11
<b>3 MOTLoad Firmware</b> .....	<b>15</b>
Introduction .....	15
Overview .....	15
MOTLoad Implementation and Memory Requirements .....	15
MOTLoad Commands .....	15
MOTLoad Utility Applications .....	16
MOTLoad Tests .....	16
Using MOTLoad .....	17
Command Line Interface .....	17
Command Line Help .....	18

Command Line Rules .....	18
MOTLoad Command List .....	19
Default VME Settings .....	23
Firmware Settings .....	25
CR/CSR Settings .....	25
Displaying VME Settings .....	25
Editing VME Settings .....	26
Deleting VME Settings .....	27
Restoring Default VME Settings .....	27
Remote Start .....	27
Alternate Boot Images and Safe Start .....	29
Firmware Startup Sequence Following Reset .....	29
Firmware Scan for Boot Image .....	30
Valid Boot Images .....	31
Checksum Algorithm .....	31
MOTLoad Image Flags .....	32
USER Images .....	32
Alternate Boot Data Structure .....	33
<b>4 Functional Description .....</b>	<b>35</b>
Features .....	35
Block Diagrams .....	38
Processor .....	39
System Memory .....	39
Local Bus Interface .....	39
Flash Memory .....	40
Control and Timers Logic .....	40
I2C Serial Interface and Devices .....	40
Ethernet Interfaces .....	41
Asynchronous Serial Ports .....	41
PCI/PCI-X Interfaces and Devices .....	42
MPC8540 PCI-X Interface .....	42
TSi148 VME Controller .....	42
Serial ATA Host Controller .....	42
PCI-X-to-PCI-X Bridges .....	43
PCI Mezzanine Card Slots .....	43
USB .....	44
PMC Expansion .....	44
General-Purpose Timers .....	44
Real-time Clock Battery .....	44
Reset Control Logic .....	45
Debug Support .....	45
<b>5 Pin Assignments .....</b>	<b>47</b>
Introduction .....	47



---

Connectors .....	48
PMC Expansion Connector (J4) .....	48
Ethernet Connectors (GENET1/J41B, GENET2/J2B, ENET1/J2A) .....	50
PCI Mezzanine Card (PMC) Connectors (J11 – J14, J21 – J23) .....	51
Serial Port Connectors (COM1/J41A, COM2–COM5/J2A-D) .....	58
VMEbus P1 Connector .....	59
VMEbus P2 Connector .....	60
MVME721 PMC I/O Module (PIM) Connectors (J10, J14) .....	61
Planar sATA Power Connector (J30) .....	62
USB Connector (J27) .....	62
sATA Connectors (J28 and J29) .....	63
Headers .....	63
Boundary Scan Header (J24) .....	63
Processor COP Header (J25) .....	64
<b>A Specifications .....</b>	<b>65</b>
Power Requirements .....	65
Supply Current Requirements .....	65
Environmental Specifications .....	65
<b>B Related Documentation .....</b>	<b>67</b>
Motorola Computer Group Documents .....	67
Manufacturers' Documents .....	68
Related Specifications .....	70

# List of Figures

---

Figure 1-1. MVME3100 Board Layout .....	4
Figure 4-1. MVME3100 Block Diagram .....	38
Figure 4-2. MVME721 RTM Block Diagram .....	39

# List of Tables

---

Table 1-1. Startup Overview	2
Table 1-2. Configuration Switch (S4) Settings	5
Table 1-3. Geographical Address Switch Assignments	6
Table 1-4. Slot Geographical Address Settings	6
Table 1-5. RTM EEPROM Address Switch Assignments	7
Table 1-6. EEPROM Address Settings	8
Table 1-7. MVME3100 Connectors	9
Table 1-8. MVME721 Rear Transition Module Connectors	9
Table 2-1. Front-Panel LED Status Indicators	11
Table 2-2. MVME721 LED Status Indicators	12
Table 2-3. Additional Onboard Status Indicators	12
Table 3-1. MOTLoad Commands	19
Table 3-2. MOTLoad Image Flags	32
Table 4-1. MVME3100 Features Summary	35
Table 4-2. MVME721 RTM Features Summary	37
Table 5-1. PMC Expansion Connector (J4) Pin Assignments	48
Table 5-2. Ethernet Connectors Pin Assignment	50
Table 5-3. PMC Slot 1 Connector (J11) Pin Assignments	51
Table 5-4. PMC Slot 1 Connector (J12) Pin Assignments	52
Table 5-5. PMC Slot 1 Connector (J13) Pin Assignments	53
Table 5-6. PMC Slot 1 Connector (J14) Pin Assignments	54
Table 5-7. PMC Slot 2 Connector (J21) Pin Assignments	55
Table 5-8. PMC Slot 2 Connector (J22) Pin Assignments	56
Table 5-9. PMC Slot 2 Connector (J23) Pin Assignments	57
Table 5-10. COM Port Connector Pin Assignments	58
Table 5-11. VMEbus P1 Connector Pin Assignments	59
Table 5-12. VME P2 Connector Pinouts	60
Table 5-13. MVME721 Host I/O Connector (J10) Pin Assignments	61
Table 5-14. Planar sATA Power Connector (J30) Pin Assignments	62
Table 5-15. USB Connector (J27) Pin Assignments	62
Table 5-16. sATA Connectors (J28 and J29) Pin Assignments	63
Table 5-17. Boundary Scan Header (J24) Pin Assignments	63
Table 5-18. Processor COP Header (J25) Pin Assignments	64
Table A-1. Power Requirements	65
Table A-2. MVME3100 Specifications	65
Table B-1. Motorola Computer Group Documents	67
Table B-2. Manufacturers' Documents	68
Table B-3. Related Specifications	70

# About This Manual

---

The *MVME3100 Single-Board Computer Installation and Use* manual provides the information you will need to install and configure your MVME3100 single-board computer and MVME721 rear transition module (RTM). It provides specific preparation and installation information, and data applicable to the board.

As of the printing date of this manual, the MVME3100 supports the models listed below.

Model Number	Description
MVME3100-1152	677 MHz MPC8540 PowerQUICC III™ integrated processor, 256MB DDR SDRAM, 64MB flash, Gigabit Ethernet, SATA, IEEE handles
MVME3100-1263	833 MHz MPC8540 PowerQUICC III integrated processor, 512MB DDR SDRAM, 128MB flash, Gigabit Ethernet, SATA, USB, PCI expansion connector, IEEE handles
MVME721-101	Rear Transition Module, direct connect, 75mm, PIM socket for PMC-1 I/O, four serial, 10/100/1000 Enet, 10/100 Enet

## Overview of Contents

This manual is divided into the following chapters and appendices:

[Chapter 1, \*Hardware Preparation and Installation\*](#), provides MVME3100 board preparation and installation instructions, as well as ESD precautionary notes.

[Chapter 2, \*Startup and Operation\*](#), provides the power-up procedure and identifies the switches and indicators on the MVMEM3100.

[Chapter 3, \*MOTLoad Firmware\*](#), describes the basic features of the MOTLoad firmware product.

[Chapter 4, \*Functional Description\*](#), describes the MVME3100 and the MVME721 RTM on a block diagram level.

[Chapter 5, \*Pin Assignments\*](#), provides pin assignments for various headers and connectors on the MVME3100 single-board computer.

[Appendix A, \*Specifications\*](#), provides power requirements and environmental specifications.

[Appendix B, \*Related Documentation\*](#), provides a listing of related Motorola manuals, vendor documentation, and industry specifications.

## Comments and Suggestions

Motorola welcomes and appreciates your comments on its documentation. We want to know what you think about our manuals and how we can make them better. Mail comments to:

Motorola, Inc.  
Embedded Communications Computing  
Reader Comments DW278  
2900 S. Diablo Way  
Tempe, Arizona 85282

You can also submit comments to the following e-mail address:

[reader-comments@mcg.mot.com](mailto:reader-comments@mcg.mot.com)

In all your correspondence, please list your name, position, and company. Be sure to include the title and part number of the manual and tell how you used it. Then tell us your feelings about its strengths and weaknesses and any recommendations for improvements.

## Conventions Used in This Manual

The following typographical conventions are used in this document:

### **bold**

is used for user input that you type just as it appears; it is also used for commands, options and arguments to commands, and names of programs, directories and files.

### *italic*

is used for names of variables to which you assign values, for function parameters, and for structure names and fields. Italic is also used for comments in screen displays and examples, and to introduce new terms.

### `courier`

is used for system output (for example, screen displays, reports), examples, and system prompts.

### **<Enter>**, **<Return>** or **<CR>**

represents the carriage return or Enter key.

### **Ctrl**

represents the Control key. Execute control characters by pressing the **Ctrl** key and the letter simultaneously, for example, **Ctrl-d**.

## Introduction

This chapter contains the following information:

- Board preparation and installation instructions
- ESD precautionary notes

## Description

The MVME3100 is a single-slot, single-board computer based on the MPC8540 PowerQUICC III™ integrated processor. The MVME3100 provides serial ATA (sATA), USB 2.0, 2eSST VMEbus interfaces, dual 64-bit/100 MHz PMC sites, up to 128MB of Flash, dual 10/100/1000 Ethernet, one 10/100 Ethernet, and five serial ports. This board supports front and rear I/O and a single SODIMM module for DDR memory. Access to rear I/O is available with the MVME721 rear transition module (RTM).

Front-panel connectors on the MVME3100 board include: one RJ-45 connector for the Gigabit Ethernet, one RJ-45 connector for the asynchronous serial port, one USB port with one type A connector, one sATA port with one external sATA connector, and a combined reset and abort switch.

Rear-panel connectors on the MVME721 board include: one RJ-45 connector for each of the 10/100 and 10/100/1000 BaseT Ethernets and four RJ-45 connectors for the asynchronous serial ports. The RTM also provides two planar connectors for one PIM with rear I/O.

## Getting Started

This section provides an overview of the steps necessary to install and power up the MVME3100 and a brief section on unpacking and ESD precautions.

## Overview of Startup Procedures

The following table lists the things you will need to do before you can use this board and tells where to find the information you need to perform each step. Be sure to read this entire chapter, including all Caution and Warning notes, before you begin.

**Table 1-1. Startup Overview**

What you need to do...	Refer to...
Unpack the hardware.	<a href="#">Unpacking Guidelines on page 2</a>
Identify various components on the board.	<a href="#">MVME3100 Layout on page 3</a>
Install the MVME3100 board in a chassis.	<a href="#">Installing the MVME3100 into a Chassis on page 8</a>
Connect any other equipment you will be using	<a href="#">Connection to Peripherals on page 9</a>
Verify the hardware is installed.	<a href="#">Completing the Installation on page 10</a>

## Unpacking Guidelines

Unpack the equipment from the shipping carton. Refer to the packing list and verify that all items are present. Save the packing material for storing and reshipping of equipment.

**Note** If the shipping carton is damaged upon receipt, request that the carrier's agent be present during the unpacking and inspection of the equipment.



**Caution**

**Avoid touching areas of integrated circuitry; static discharge can damage circuits.**

Use ESD

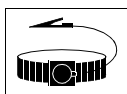

Wrist Strap

Motorola strongly recommends that you use an antistatic wrist strap and a conductive foam pad when installing or upgrading a system. Electronic components, such as disk drives, computer boards, and memory modules can be extremely sensitive to electrostatic discharge (ESD). After removing the component from its protective wrapper or from the system, place the component flat on a grounded, static-free surface (and, in the case of a board, component side up). Do not slide the component over any surface.

If an ESD station is not available, you can avoid damage resulting from ESD by wearing an antistatic wrist strap (available at electronics stores) that is attached to an active electrical ground. Note that a system chassis may not be grounded if it is unplugged.



**Caution**

**Inserting or removing modules with power applied may result in damage to module components.**



**Dangerous voltages, capable of causing death, are present in this equipment. Use extreme caution when handling, testing, and adjusting.**

## Hardware Configuration

This section discusses certain hardware and software tasks that may need to be performed prior to installing the board in a chassis.

To produce the desired configuration and ensure proper operation of the MVME3100, you may need to carry out certain hardware modifications before installing the module.

Most options on the MVME3100 are software configurable. Configuration changes are made by setting bits in control registers after the board is installed in a system.

Jumpers/switches are used to control those options that are not software configurable. These jumper settings are described further on in this section. If you are resetting the board jumpers from their default settings, it is important to verify that all settings are reset properly.

### MVME3100 Layout

[Figure 1-1 on page 4](#) illustrates the placement of the jumpers, headers, connectors, switches, and various other components on the MVME3100.

There are two switch blocks which have user-selectable settings. Refer to [Table 1-2](#), [Table 1-3](#), and [Table 1-4](#) for switch settings. There is one switch on the MVME721. Refer to [Table 1-5](#) and [Table 1-6](#) for switch settings.



The MVME3100 is factory tested and shipped with the configuration described in the following sections.

**Figure 1-1. MVME3100 Board Layout**

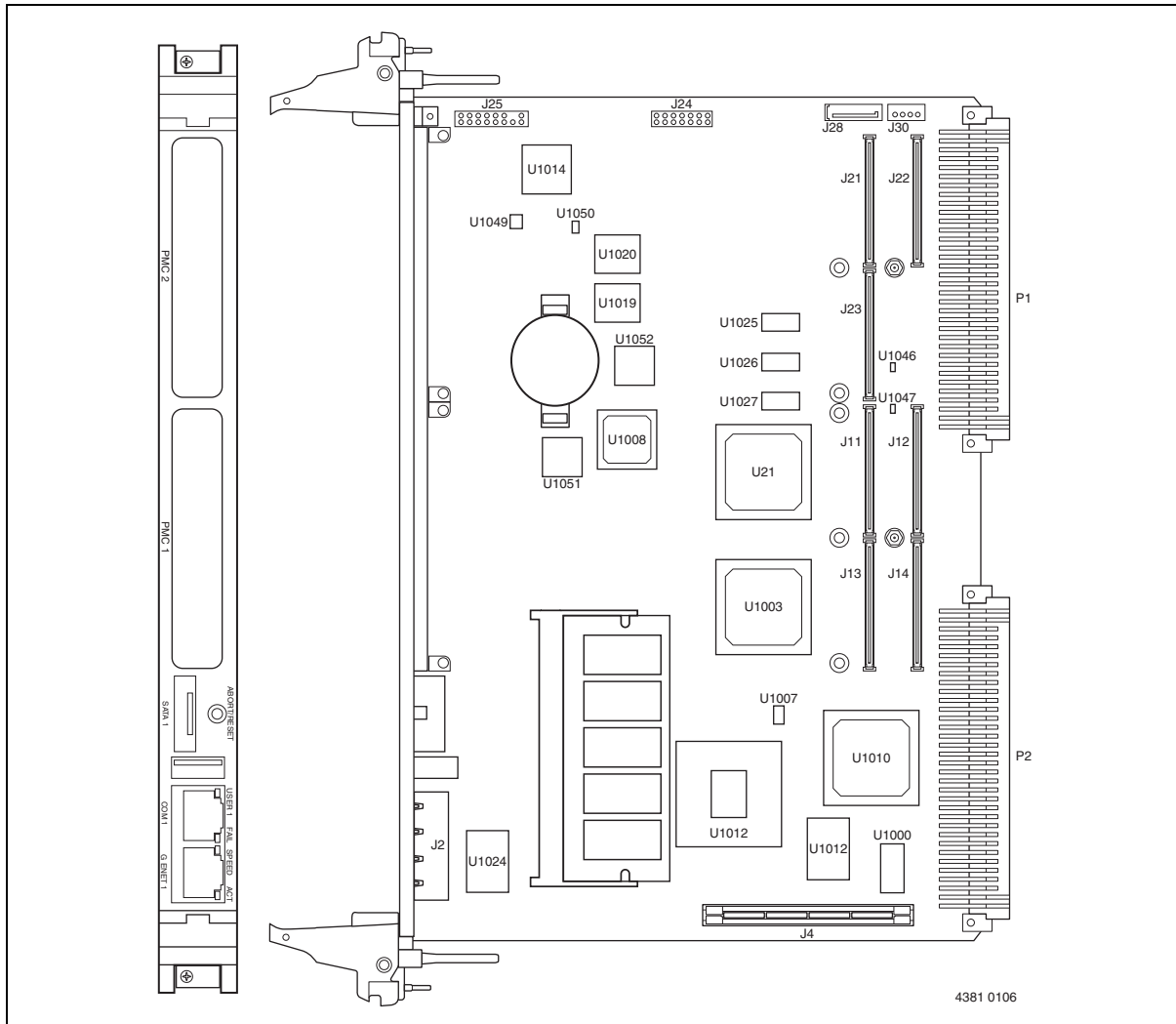

## Configuration Switch (S4)

An 8-position SMT configuration switch controls the VME SCON setting, Flash bank write-protect, and the safe start ENV settings. It also selects the Flash boot image. The default setting on all switch positions is OFF.

**Table 1-2. Configuration Switch (S4) Settings**

Switch	Pos.	Setting		Notes
		OFF (Factory Default)	ON	
SAFE_START	1	Normal ENV settings should be used.	Safe ENV settings should be used.	This switch status is readable from System Status register 1, bit 5. Software may check this bit and act accordingly.
BOOT BLOCK SELECT	2	Flash memory map is normal and boot block A is selected.	Boot block B is selected and mapped to the highest address.	
FLASH BANK WP	3	Entire Flash is not write-protected.	Flash is write-protected.	
Reserved	4			
VME SCON AUTO/MANUAL MODE	5	Auto-SCON mode.	Manual SCON mode.	Manual SCON mode works in conjunction with the VME SCON SELECT switch.
MANUAL VME SCON SELECT	6	Non-SCON mode.	Always SCON mode.	This switch is only effective when the VME SCON AUTO/MANUAL MODE switch is ON.
sATA Mode	7	Legacy Mode	sATA Mode	Sets GD31244 to legacy or sATA mode during reset
TRST SELECT	8	Normal MPC8540 TRST mode where the board HRESET will assert TRST.	Isolates the board HRESET from TRST and allows the board to reset without resetting the MPC8540 JTAG/COP interface.	This switch should remain in the OFF position unless a MPC8540 emulator is attached.

## Geographical Address Switch (S3)

The TSi148 VMEbus Status register provides the VMEbus geographical address of the MVME3100. This switch reflects the inverted states of the geographical address signals. Applications not using the 5-row backplane can use the geographical address switch to assign a geographical address.

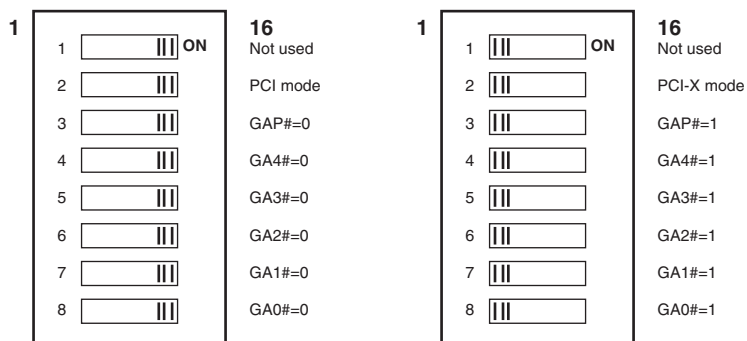

4389 0106

**Table 1-3. Geographical Address Switch Assignments**

Position	SW1	SW2 <sup>1</sup>	SW3	SW4	SW5	SW6	SW7	SW8
Function	Not Used	PCI Bus A mode	GAP	GA4	GA3	GA2	GA1	GA0
(Factory) OFF	X	PCI-X mode	1	1	1	1	1	1

**Note** <sup>1</sup>SW2 configures the operating mode of PCI Bus A during power up. In the default (OFF) position, the bus is configured for PCI-X mode. In the ON position, the bus is configured for PCI mode.

**Table 1-4. Slot Geographical Address Settings**

Slot Address	GAP GA(4:0)	SW3	SW4	SW5	SW6	SW7	SW8
1	1 11110	OFF	OFF	OFF	OFF	OFF	ON
2	1 11101	OFF	OFF	OFF	OFF	ON	OFF
3	0 11100	ON	OFF	OFF	OFF	ON	ON
4	1 11011	OFF	OFF	OFF	ON	OFF	OFF
5	0 11010	ON	OFF	OFF	ON	OFF	ON
6	0 11001	ON	OFF	OFF	ON	ON	OFF
7	1 11000	OFF	OFF	OFF	ON	ON	ON
8	1 10111	OFF	OFF	ON	OFF	OFF	OFF
9	0 10110	ON	OFF	ON	OFF	OFF	ON

**Table 1-4. Slot Geographical Address Settings (continued)**

Slot Address	GAP GA(4:0)	SW3	SW4	SW5	SW6	SW7	SW8
10	0 10101	ON	OFF	ON	OFF	ON	OFF
11	1 10100	OFF	OFF	ON	OFF	ON	ON
12	0 10011	ON	OFF	ON	ON	OFF	OFF
13	1 10010	OFF	OFF	ON	ON	OFF	ON
14	1 10001	OFF	OFF	ON	ON	ON	OFF
15	0 10000	ON	OFF	ON	ON	ON	ON
16	1 01111	OFF	ON	OFF	OFF	OFF	OFF
17	0 01110	ON	ON	OFF	OFF	OFF	ON
18	0 01101	ON	ON	OFF	OFF	ON	OFF
19	1 01100	OFF	ON	OFF	OFF	ON	ON
20	0 01011	ON	ON	OFF	ON	OFF	OFF
21	1 01010	OFF	ON	OFF	ON	OFF	ON

## PMC I/O Voltage Configuration

The onboard PMC sites may be configured to support 3.3V or 5.0V I/O PMC modules. To support 3.3V or 5.0V I/O PMC modules, both PMC I/O keying pins must be installed in the holes. If both keying pins are not in the same location or if the keying pins are not installed, the PMC sites will not function. Note that setting the PMC I/O voltage to 5.0V forces the PMC sites to operate in PCI mode instead of PCI-X mode. The default factory configuration is for 3.3V PMC I/O voltage.

## RTM EEPROM Address Switch (S1)

A 4-position SMT configuration switch is located on the RTM to set the device address of the RTM serial EEPROM device. The switch settings are defined in the following table.

**Table 1-5. RTM EEPROM Address Switch Assignments**

Position	SW1	SW2	SW3	SW4
Function	A0	A1	A2	Not Used
OFF	1	1	1	

**Table 1-6. EEPROM Address Settings**

Device Address	A(2:0)	SW1	SW2	SW3
\$A0	000	ON	ON	ON
\$A2	001	OFF	ON	ON
\$A4	010	ON	OFF	ON
\$A6	011	OFF	OFF	ON
\$A8	100	ON	ON	OFF
\$AA (Factory)	101	OFF	ON	OFF
\$AC	110	ON	OFF	OFF
\$AE	111	OFF	OFF	OFF

**Note** The RTM EEPROM address switches must be set for address \$AA in order for this device to be accessible by MotLoad.

## Hardware Installation

### Installing the MVME3100 into a Chassis

Use the following steps to install the MVME3100 into your computer chassis.

1. Attach an ESD strap to your wrist. Attach the other end of the ESD strap to an electrical ground (refer to *Unpacking Guidelines*). The ESD strap must be secured to your wrist and to ground throughout the procedure.
2. Remove any filler panel that might fill that slot.
3. Install the top and bottom edge of the MVME3100 into the guides of the chassis.



**Warning**

**Only use injector handles for board insertion to avoid damage/deformation to the front panel and/or PCB. Deformation of the front panel can cause an electrical short or other board malfunction.**

4. Ensure that the levers of the two injector/ejectors are in the outward position.
5. Slide the MVME3100 into the chassis until resistance is felt.
6. Simultaneously move the injector/ejector levers in an inward direction.
7. Verify that the MVME3100 is properly seated and secure it to the chassis using the two screws located adjacent to the injector/ejector levers.
8. Connect the appropriate cables to the MVME3100.

To remove the board from the chassis, press the red locking tabs (IEEE handles only) and reverse the procedure.

## Connection to Peripherals

When the MVME3100 is installed in a chassis, you are ready to connect peripherals and apply power to the board.

Figure 1-1 on page 4 shows the locations of the various connectors while Table 1-7 and Table 1-8 list them for you. Refer to Chapter 5, *Pin Assignments* for the pin assignments of the connectors listed below.

**Table 1-7. MVME3100 Connectors**

Connector	Function
J4	PMC expansion connector
J11, J12, J13, J14	PCI mezzanine card (PMC) slot 1 connector
J21, J22, J23	PCI mezzanine card (PMC) slot 2 connector
J24	Boundary scan header
J25	COP header
J27	USB connector
J28	Front panel sATA connector
J29	Planar sATA connector
J30	Planar sATA power connector
J41B	10/100/1000Mb/s Ethernet connector
J41A	COM port connector
P1, P2	VME backplane connectors

**Table 1-8. MVME721 Rear Transition Module Connectors**

Connector	Function
J1A, J1B, J1C, J1D	COM port connectors
J2A	10/100/1000Mb/s Ethernet connector
J2B	10/100Mb/s Ethernet connector
J10	PIM power/ground
J14	PIM I/O
P2	VME backplane connector

## Completing the Installation

Verify that hardware is installed and the power/peripheral cables connected are appropriate for your system configuration.

Replace the chassis or system cover, reconnect the system to the AC or DC power source, and turn the equipment power on.

## Introduction

This chapter gives you information about the:

- Power-up procedure
- Runtime switches and indicators

## Applying Power

After you verify that all necessary hardware preparation is complete and all connections are made correctly, you can apply power to the system.

When you are ready to apply power to the MVME3100:

- Verify that the chassis power supply voltage setting matches the voltage present in the country of use (if the power supply in your system is not auto-sensing)
- On powering up, the MVME3100 brings up the MOTLoad prompt, `MVME3100>`

## Switches and Indicators

The MVME3100 board provides a single push button switch that provides both abort and reset (ABT/RST) functions. When the switch is pressed for less than five seconds, an abort interrupt is generated to the processor. If the switch is held for more than five seconds, a board hard reset is generated. The board hard reset will reset the MPC8540, local PCI/PCI-X buses, Ethernet PHYs, serial ports, Flash devices, and PLD(s). If the MVME3100 is configured as the VME system controller, the VME bus and local TSi148 reset input are also reset.

The MVME3100 has four front-panel indicators. The following table describes these indicators:

**Table 2-1. Front-Panel LED Status Indicators**

Function	Label	Color	Description
Board Fail	FAIL	Yellow	Board has a failure. After Power On or reset, this LED is ON until extinguished by firmware or software.
User Defined	USER 1	Green	This indicator is illuminated by software assertion of its corresponding register bit.



**Table 2-1. Front-Panel LED Status Indicators (continued)**

Function	Label	Color	Description
GENET 1 Link / Speed	SPEED	Off	No link
		Yellow	10/100Base-T operation
		Green	1000Base-T operation
GENET 1 Activity	ACT	Blinking Green	Activity proportional to bandwidth utilization.
		Off	No activity

The MVME721 rear transition module also has four status indicators. The following table describes these indicators:

**Table 2-2. MVME721 LED Status Indicators**

Function	Label	Color	Description
GENET 2 Link/Speed	SPEED	Off	No link
		Yellow	10/100Base-T operation
		Green	1000Base-T operation
GENET 2 Activity	ACT	Blinking Green	Activity proportional to bandwidth utilization.
		Off	No activity
ENET 1 Link/Speed	SPEED	Off	No link
		Yellow	10/100Base-T operation
ENET 1 Activity	ACT	Blinking Green	Activity proportional to bandwidth utilization.
		Off	No activity

**Table 2-3. Additional Onboard Status Indicators**

Function	Label	Color	Description
User Defined LED 2	DS7 (silkscreen)	Green	This indicator is illuminated by software assertion of its corresponding register bit.
User Defined LED 3	DS8 (silkscreen)	Green	This indicator is illuminated by software assertion of its corresponding register bit.
Power Supply Fail	DS1 (silkscreen)	Red	This indicator is illuminated to indicate a power supply fail condition.
sATA 0 Activity	DS4 (silkscreen)	Green	sATA 0 or 1 activity in legacy mode (default). sATA 0 activity in DPA mode.

**Table 2-3. Additional Onboard Status Indicators (continued)**

Function	Label	Color	Description
sATA 1 Activity	DS5 (silkscreen)	Green	No function in legacy mode (default). sATA 1 activity in DPA mode.
MPC8540 Ready	DS3 (silkscreen)	Green	Indicates that the MPC8540 has completed the reset operation and is not in a power-down state. The MPC8540 Ready is multiplexed with the MPC8540 TRIG_OUT so the LED can be programmed to indicate one of three trigger events based on the value in the MPC8540 TOSR register.
GENET 1 Link Quality	DS2 (silkscreen)	Off Slow Blink Green Fast Blink Green Green	Extremely poor Signal to Noise ratio - cannot receive data Poor SNR - receive errors detected Fair SNR - close to data error threshold Good SNR on link
GENET 2 Link Quality	DS3	[Same as DS2]	

---

## Introduction

This chapter describes the basic features of the MOTLoad firmware product, designed by Motorola as the next generation initialization, debugger, and diagnostic tool for high-performance embedded board products using state-of-the-art system memory controllers and bridge chips, such as the MPC8540 processor.

In addition to an overview of the product, this chapter includes a list of standard MOTLoad commands, the default VME and firmware settings that are changeable by the user, remote start, and the alternate boot procedure.

## Overview

The MOTLoad firmware package serves as a board power-up and initialization package, as well as a vehicle from which user applications can be booted. A secondary function of the MOTLoad firmware is to serve in some respects as a test suite providing individual tests for certain devices.

MOTLoad is controlled through an easy-to-use, UNIX-like, command line interface. The MOTLoad software package is similar to many end-user applications designed for the embedded market, such as the real time operating systems currently available.

Refer to the *MOTLoad Firmware Package User's Manual*, listed in [Appendix B, Related Documentation](#), for more details.

## MOTLoad Implementation and Memory Requirements

The implementation of MOTLoad and its memory requirements are product specific. The MVME3100 single-board computer (SBC) is offered with a range of memory (for example, DRAM or flash). Typically, the smallest amount of on-board DRAM that a Motorola SBC has is 32MB. Each supported Motorola product line has its own unique *MOTLoad* binary image(s). Currently the largest *MOTLoad* compressed image is less than 1MB in size.

## MOTLoad Commands

MOTLoad supports two types of commands (applications): utilities and tests. Both types of commands are invoked from the MOTLoad command line in a similar fashion. Beyond that, MOTLoad utilities and MOTLoad tests are distinctly different.

## MOTLoad Utility Applications

The definition of a MOTLoad utility application is very broad. Simply stated, it is considered a MOTLoad command, if it is not a MOTLoad test. Typically, MOTLoad utility applications are applications that aid the user in some way (that is, they do something useful). From the perspective of MOTLoad, examples of utility applications are: configuration, data/status displays, data manipulation, help routines, data/status monitors, etc.

Operationally, MOTLoad utility applications differ from MOTLoad test applications in several ways:

- Only one utility application operates at any given time (that is, multiple utility applications cannot be executing concurrently)
- Utility applications may interact with the user. Most test applications do not.

## MOTLoad Tests

A MOTLoad test application determines whether or not the hardware meets a given standard. Test applications are validation tests. Validation is conformance to a specification. Most MOTLoad tests are designed to directly validate the functionality of a specific SBC subsystem or component. These tests validate the operation of such SBC modules as: dynamic memory, external cache, NVRAM, real time clock, etc.

All MOTLoad tests are designed to validate functionality with minimum user interaction. Once launched, most MOTLoad tests operate automatically without any user interaction. There are a few tests where the functionality being validated requires user interaction (that is, switch tests, interactive plug-in hardware modules, etc.). Most MOTLoad test results (error-data/status-data) are logged, not printed. All MOTLoad tests/commands have complete and separate descriptions (refer to the MOTLoad Firmware Package User's Manual for this information).

All devices that are available to MOTLoad for validation/verification testing are represented by a unique device path string. Most MOTLoad tests require the operator to specify a test device at the MOTLoad command line when invoking the test.

A listing of all device path strings can be displayed through the **devShow** command. If an SBC device does not have a device path string, it is not supported by MOTLoad and can not be directly tested. There are a few exceptions to the device path string requirement, like testing RAM, which is not considered a true device and can be directly tested without a device path string. Refer to the **devShow** command description page in the MOTLoad Firmware Package User's Manual.

Most MOTLoad tests can be organized to execute as a group of related tests (a testSuite) through the use of the **testSuite** command. The expert operator can customize their testing by defining and creating a custom testSuite(s). The list of built-in and user-defined MOTLoad testSuites, and their test contents, can be obtained by entering **testSuite -d** at the MOTLoad prompt. All testSuites that are included as part of a product specific MOTLoad firmware package are product specific. For more information, refer to the **testSuite** command description page in the MOTLoad Firmware Package User's Manual.

Test results and test status are obtained through the **testStatus**, **errorDisplay**, and **taskActive** commands. Refer to the appropriate command description page in the MOTLoad Firmware Package User's Manual for more information.

## Using MOTLoad

Interaction with MOTLoad is performed via a command line interface through a serial port on the SBC, which is connected to a terminal or terminal emulator (for example, Window's Hypercomm). The default MOTLoad serial port settings are: 9600 baud, 8 bits, no parity.

## Command Line Interface

The MOTLoad command line interface is similar to a UNIX command line shell interface. Commands are initiated by entering a valid MOTLoad command (a text string) at the MOTLoad command line prompt and pressing the carriage-return key to signify the end of input. MOTLoad then performs the specified action. An example of a MOTLoad command line prompt is shown below. The MOTLoad prompt changes according to what product it is used on (for example, MVME6100, MVME3100).

Example:

```
MVME3100>
```

If an invalid MOTLoad command is entered at the MOTLoad command line prompt, MOTLoad displays a message that the command was not found.

Example:

```
MVME3100> mytest
```

```
"mytest" not found  
MVME3100>
```

If the user enters a partial MOTLoad command string that can be resolved to a unique valid MOTLoad command and presses the carriage-return key, the command is executed as if the entire command string had been entered. This feature is a user-input shortcut that minimizes the required amount of command line input. MOTLoad is an ever changing firmware package, so user-input shortcuts may change as command additions are made.

Example:

```
MVME3100> version
```

```
Copyright: Motorola Inc.1999-2005, All Rights Reserved  
MOTLoad RTOS Version 2.0, PAL Version 1.0 RM01  
Mon Aug 29 15:24:13 MST 2005  
MVME3100>
```

Example:

```
MVME3100> ver
```

```
Copyright: Motorola Inc.1999-2005, All Rights Reserved
MOTLoad RTOS Version 2.0, PAL Version 1.0 RM01
Mon Aug 29 15:24:13 MST 2005
MVME3100>
```

If the partial command string cannot be resolved to a single unique command, MOTLoad informs the user that the command was ambiguous.

Example:

```
MVME3100> te

"te" ambiguous
MVME3100>
```

## Command Line Help

Each MOTLoad firmware package has an extensive, product-specific help facility that can be accessed through the **help** command. The user can enter **help** at the MOTLoad command line to display a complete listing of all available tests and utilities.

Example

```
MVME3100> help
```

For help with a specific test or utility the user can enter the following at the MOTLoad prompt:

**help <command\_name>**

The **help** command also supports a limited form of pattern matching. Refer to the **help** command page.

Example

```
MVME3100> help testRam

Usage: testRam [-aPh] [-bPh] [-iPd] [-nPh] [-tPd] [-v]
Description: RAM Test [Directory]
Argument/Option Description
-a Ph: Address to Start (Default = Dynamic Allocation)
-b Ph: Block Size (Default = 16KB)
-i Pd: Iterations (Default = 1)
-n Ph: Number of Bytes (Default = 1MB)
-t Ph: Time Delay Between Blocks in OS Ticks (Default = 1)
-v O : Verbose Output
MVME3100>
```

## Command Line Rules

There are a few things to remember when entering a MOTLoad command:

- Multiple commands are permitted on a single command line, provided they are separated by a single semicolon (;)
- Spaces separate the various fields on the command line (command/arguments/options)

- The argument/option identifier character is always preceded by a hyphen (-) character
- Options are identified by a single character
- Option arguments immediately follow (no spaces) the option
- All commands, command options, and device tree strings are case sensitive

Example:

```
MVME3100> flashProgram -d/dev/flash0 -n00100000
```

For more information on MOTLoad operation and function, refer to the *MOTLoad Firmware Package User's Manual*.

## MOTLoad Command List

The following table provides a list of all current MOTLoad commands. Products supported by MOTLoad may or may not employ the full command set. Typing **help** at the MOTLoad command prompt will display all commands supported by MOTLoad for a given product.

**Table 3-1. MOTLoad Commands**

Command	Description
<b>as</b>	One-Line Instruction Assembler
<b>bc bch bcw</b>	Block Compare Byte/Halfword/Word
<b>bdTempShow</b>	Display Current Board Temperature
<b>bfb bfh bfw</b>	Block Fill Byte/Halfword/Word
<b>blkCp</b>	Block Copy
<b>blkFmt</b>	Block Format
<b>blkRd</b>	Block Read
<b>blkShow</b>	Block Show Device Configuration Data
<b>blkVe</b>	Block Verify
<b>blkWr</b>	Block Write
<b>bmb bmh bmw</b>	Block Move Byte/Halfword/Word
<b>br</b>	Assign/Delete/Display User-Program Break-Points
<b>bsb bsh bsw</b>	Block Search Byte/Halfword/Word
<b>bvb bvh bwv</b>	Block Verify Byte/Halfword/Word
<b>cdDir</b>	ISO9660 File System Directory Listing
<b>cdGet</b>	ISO9660 File System File Load
<b>clear</b>	Clear the Specified Status/History Table(s)
<b>cm</b>	Turns on Concurrent Mode
<b>csb csh csw</b>	Calculates a Checksum Specified by Command-line Options
<b>devShow</b>	Display (Show) Device/Node Table
<b>diskBoot</b>	Disk Boot (Direct-Access Mass-Storage Device)

**Table 3-1. MOTLoad Commands (continued)**

Command	Description
<b>downLoad</b>	Down Load S-Record from Host
<b>ds</b>	One-Line Instruction Disassembler
<b>echo</b>	Echo a Line of Text
<b>elfLoader</b>	ELF Object File Loader
<b>errorDisplay</b>	Display the Contents of the Test Error Status Table
<b>eval</b>	Evaluate Expression
<b>execProgram</b>	Execute Program
<b>fatDir</b>	FAT File System Directory Listing
<b>fatGet</b>	FAT File System File Load
<b>fdShow</b>	Display (Show) File Descriptor
<b>flashLock</b>	Flash Memory Sector Lock
<b>flashProgram</b>	Flash Memory Program
<b>flashShow</b>	Display Flash Memory Device Configuration Data
<b>flashUnlock</b>	Flash Memory Sector Unlock
<b>gd</b>	Go Execute User-Program Direct (Ignore Break-Points)
<b>gevDelete</b>	Global Environment Variable Delete
<b>gevDump</b>	Global Environment Variable(s) Dump (NVRAM Header + Data)
<b>gevEdit</b>	Global Environment Variable Edit
<b>gevInit</b>	Global Environment Variable Area Initialize (NVRAM Header)
<b>gevList</b>	Global Environment Variable Labels (Names) Listing
<b>gevShow</b>	Global Environment Variable Show
<b>gn</b>	Go Execute User-Program to Next Instruction
<b>go</b>	Go Execute User-Program
<b>gt</b>	Go Execute User-Program to Temporary Break-Point
<b>hbd</b>	Display History Buffer
<b>hbx</b>	Execute History Buffer Entry
<b>help</b>	Display Command/Test Help Strings
<b>l2CacheShow</b>	Display state of L2 Cache and L2CR register contents
<b>l3CacheShow</b>	Display state of L3 Cache and L3CR register contents
<b>mdb mdh mdw</b>	Memory Display Bytes/Halfwords/Words
<b>memShow</b>	Display Memory Allocation
<b>mmb mmh mmw</b>	Memory Modify Bytes/Halfwords/Words
<b>netBoot</b>	Network Boot (BOOT/TFTP)
<b>netShow</b>	Display Network Interface Configuration Data
<b>netShut</b>	Disable (Shutdown) Network Interface



**Table 3-1. MOTLoad Commands (continued)**

Command	Description
<b>netStats</b>	Display Network Interface Statistics Data
<b>noCm</b>	Turns off Concurrent Mode
<b>pciDataRd</b>	Read PCI Device Configuration Header Register
<b>pciDataWr</b>	Write PCI Device Configuration Header Register
<b>pciDump</b>	Dump PCI Device Configuration Header Register
<b>pciShow</b>	Display PCI Device Configuration Header Register
<b>pciSpace</b>	Display PCI Device Address Space Allocation
<b>ping</b>	Ping Network Host
<b>portSet</b>	Port Set
<b>portShow</b>	Display Port Device Configuration Data
<b>rd</b>	User Program Register Display
<b>reset</b>	Reset System
<b>rs</b>	User Program Register Set
<b>set</b>	Set Date and Time
<b>sromRead</b>	SROM Read
<b>sromWrite</b>	SROM Write
<b>sta</b>	Symbol Table Attach
<b>stl</b>	Symbol Table Lookup
<b>stop</b>	Stop Date and Time (Power-Save Mode)
<b>taskActive</b>	Display the Contents of the Active Task Table
<b>tc</b>	Trace (Single-Step) User Program
<b>td</b>	Trace (Single-Step) User Program to Address
<b>testDisk</b>	Test Disk
<b>testEnetPtP</b>	Ethernet Point-to-Point
<b>testNvramRd</b>	NVRAM Read
<b>testNvramRdWr</b>	NVRAM Read/Write (Destructive)
<b>testRam</b>	RAM Test (Directory)
<b>testRamAddr</b>	RAM Addressing
<b>testRamAlt</b>	RAM Alternating
<b>testRamBitToggle</b>	RAM Bit Toggle
<b>testRamBounce</b>	RAM Bounce
<b>testRamCodeCopy</b>	RAM Code Copy and Execute
<b>testRamEccMonitor</b>	Monitor for ECC Errors
<b>testRamMarch</b>	RAM March
<b>testRamPatterns</b>	RAM Patterns

**Table 3-1. MOTLoad Commands (continued)**

Command	Description
<b>testRamPerm</b>	RAM Permutations
<b>testRamQuick</b>	RAM Quick
<b>testRamRandom</b>	RAM Random Data Patterns
<b>testRtcAlarm</b>	RTC Alarm
<b>testRtcReset</b>	RTC Reset
<b>testRtcRollOver</b>	RTC Rollover
<b>testRtcTick</b>	RTC Tick
<b>testSerialExtLoop</b>	Serial External Loopback
<b>testSerialIntLoop</b>	Serial Internal Loopback
<b>testStatus</b>	Display the Contents of the Test Status Table
<b>testSuite</b>	Execute Test Suite
<b>testSuiteMake</b>	Make (Create) Test Suite
<b>testThermoOp</b>	Thermometer Temp Limit Operational Test
<b>testThermoQ</b>	Thermometer Temp Limit Quick Test
<b>testThermoRange</b>	Tests That Board Thermometer is Within Range
<b>testWatchdogTimer</b>	Tests the Accuracy of the Watchdog Timer Device
<b>tftpGet</b>	TFTP Get
<b>tftpPut</b>	TFTP Put
<b>time</b>	Display Date and Time
<b>transparentMode</b>	Transparent Mode (Connect to Host)
<b>tsShow</b>	Display Task Status
<b>upLoad</b>	Up Load Binary Data from Target
<b>version</b>	Display Version String(s)
<b>vmeCfg</b>	Manages user specified VME configuration parameters
<b>vpdDisplay</b>	VPD Display
<b>vpdEdit</b>	VPD Edit
<b>waitProbe</b>	Wait for I/O Probe to Complete

## Default VME Settings

As shipped from the factory, the MVME3100 has the following VME configuration programmed via Global Environment Variables (GEVs) for the Tsi148 VME controller. The firmware allows certain VME settings to be changed in order for the user to customize the environment. The following is a description of the default VME settings that are changeable by the user. For more information, refer to the *MOTLoad User's Manual* and Tundra's *Tsi148 User Manual*, listed in [Appendix B, Related Documentation](#).

■ MVME3100> **vmeCfg -s -m**

```
Displaying the selected Default VME Setting
- interpreted as follows:
VME PCI Master Enable [Y/N] = Y
MVME3100>
```

The PCI Master is enabled.

■ MVME3100> **vmeCfg -s -r234**

```
Displaying the selected Default VME Setting
- interpreted as follows:
VMEbus Master Control Register = 00000003
MVME3100>
```

The VMEbus Master Control Register is set to the default (RESET) condition.

■ MVME3100> **vmeCfg -s -r238**

```
Displaying the selected Default VME Setting
- interpreted as follows:
VMEbus Control Register = 00000008
MVME3100>
```

The VMEbus Control Register is set to a Global Timeout of 2048  $\mu$ seconds.

■ MVME3100> **vmeCfg -s -r414**

```
Displaying the selected Default VME Setting
- interpreted as follows:
CRG Attribute Register = 00000000
CRG Base Address Upper Register = 00000000
CRG Base Address Lower Register = 00000000
MVME3100>
```

The CRG Attribute Register is set to the default (RESET) condition.

■ MVME3100> **vmeCfg -s -i0**

```
Displaying the selected Default VME Setting
- interpreted as follows:
Inbound Image 0 Attribute Register = 000227AF
Inbound Image 0 Starting Address Upper Register = 00000000
Inbound Image 0 Starting Address Lower Register = 00000000
Inbound Image 0 Ending Address Upper Register = 00000000
Inbound Image 0 Ending Address Lower Register = 1FFF0000
Inbound Image 0 Translation Offset Upper Register = 00000000
Inbound Image 0 Translation Offset Lower Register = 00000000
MVME3100>
```

Inbound window 0 (ITAT0) is not enabled; Virtual FIFO at 256 bytes, 2eSST timing at SST320, respond to 2eSST, 2eVME, MBLT, and BLT cycles, A32 address space, respond to Supervisor, User, Program, and Data cycles. Image maps from 0x00000000 to 0x1FFF0000 on the Vmbus, translates 1x1 to the PCI-X bus (thus 1x1 to local memory). To enable this window, set bit 31 of ITAT0 to 1.

**Note** For Inbound Translations, the Upper Translation Offset Register needs to be set to 0xFFFFFFFF to ensure proper translations to the PCI-X Local Bus.

■ MVME3100> **vmeCfg -s -o1**

```

Displaying the selected Default VME Setting
- interpreted as follows:
Outbound Image 1 Attribute Register = 80001462
Outbound Image 1 Starting Address Upper Register = 00000000
Outbound Image 1 Starting Address Lower Register = 91000000
Outbound Image 1 Ending Address Upper Register = 00000000
Outbound Image 1 Ending Address Lower Register = AFFF0000
Outbound Image 1 Translation Offset Upper Register = 00000000
Outbound Image 1 Translation Offset Lower Register = 70000000
Outbound Image 1 2eSST Broadcast Select Register = 00000000
MVME3100>

```

Outbound window 1 (OTAT1) is enabled, 2eSST timing at SST320, transfer mode of 2eSST, A32/D32 Supervisory access. The window accepts transfers on the PCI-X Local Bus from 0x91000000-0xAFFF0000 and translates them onto the VMEbus using an offset of 0x70000000, thus an access to 0x91000000 on the PCI-X Local Bus becomes an access to 0x01000000 on the VMEbus.

■ MVME3100> **vmeCfg -s -o2**

```

Displaying the selected Default VME Setting
- interpreted as follows:
Outbound Image 2 Attribute Register = 80001061
Outbound Image 2 Starting Address Upper Register = 00000000
Outbound Image 2 Starting Address Lower Register = B0000000
Outbound Image 2 Ending Address Upper Register = 00000000
Outbound Image 2 Ending Address Lower Register = B0FF0000
Outbound Image 2 Translation Offset Upper Register = 00000000
Outbound Image 2 Translation Offset Lower Register = 40000000
Outbound Image 2 2eSST Broadcast Select Register = 00000000
MVME3100>

```

Outbound window 2 (OTAT2) is enabled, 2eSST timing at SST320, transfer mode of SCT, A24/D32 Supervisory access. The window accepts transfers on the PCI-X Local Bus from 0xB0000000-0xB0FF0000 and translates them onto the VMEbus using an offset of 0x40000000, thus an access to 0xB0000000 on the PCI-X Local Bus becomes an access to 0xF0000000 on the VMEbus.

■ MVME3100> **vmeCfg -s -o3**

```

Displaying the selected Default VME Setting
- interpreted as follows:
Outbound Image 3 Attribute Register = 80001061
Outbound Image 3 Starting Address Upper Register = 00000000
Outbound Image 3 Starting Address Lower Register = B3FF0000

```

```

Outbound Image 3 Ending Address Upper Register = 00000000
Outbound Image 3 Ending Address Lower Register = B3FF0000
Outbound Image 3 Translation Offset Upper Register = 00000000
Outbound Image 3 Translation Offset Lower Register = 4C000000
Outbound Image 3 2eSST Broadcast Select Register = 00000000
MVME3100>

```

Outbound window 3 (OTAT3) is enabled, 2eSST timing at SST320, transfer mode of SCT, A16/D32 Supervisory access. The window accepts transfers on the PCI-X Local Bus from 0xB3FF0000-0xB3FF0000 and translates them onto the VMEbus using an offset of 0x4C000000, thus an access to 0xB3FF0000 on the PCI-X Local Bus becomes an access to 0xFFFF0000 on the VMEbus.

■ MVME3100> **vmeCfg -s -o7**

```

Displaying the selected Default VME Setting
- interpreted as follows:
Outbound Image 7 Attribute Register = 80001065
Outbound Image 7 Starting Address Upper Register = 00000000
Outbound Image 7 Starting Address Lower Register = B1000000
Outbound Image 7 Ending Address Upper Register = 00000000
Outbound Image 7 Ending Address Lower Register = B1FF0000
Outbound Image 7 Translation Offset Upper Register = 00000000
Outbound Image 7 Translation Offset Lower Register = 4F000000
Outbound Image 7 2eSST Broadcast Select Register = 00000000
MVME3100>

```

Outbound window 7 (OTAT7) is enabled, 2eSST timing at SST320, transfer mode of SCT, CR/CSR Supervisory access. The window accepts transfers on the PCI-X Local Bus from 0xB1000000-0xB1FF0000 and translates them onto the VMEbus using an offset of 0x4F000000, thus an access to 0xB1000000 on the PCI-X Local Bus becomes an access to 0x00000000 on the VMEbus.

## Firmware Settings

The following sections provide additional information pertaining to the VME firmware settings of the MVME3100. A few VME settings are controlled by hardware jumpers while the majority of the VME settings are managed by the firmware command utility **vmeCfg**.

### CR/CSR Settings

The CR/CSR base address is initialized to the appropriate setting based on the Geographical address; that is, the VME slot number. See the VME64 Specification and the VME64 Extensions for details. As a result, a 512K byte CR/CSR area can be accessed from the VMEbus using the CR/CSR AM code.

### Displaying VME Settings

To display the changeable VME setting, type the following at the firmware prompt:

■ To display Master Enable state

```
vmeCfg -s -m
```

- To display selected Inbound Window state  
**vmeCfg -s -i(0 - 7)**
- To display selected Outbound Window state  
**vmeCfg -s -o(0 - 7)**
- To display PCI Miscellaneous Register state  
**vmeCfg -s -r184**
- To display Special PCI Target Image Register state  
**vmeCfg -s -r188**
- To display Master Control Register state  
**vmeCfg -s -r400**
- To display Miscellaneous Control Register state  
**vmeCfg -s -r404**
- To display User AM Codes Register state  
**vmeCfg -s -r40C**
- To display VMEbus Register Access Image Control Register state  
**vmeCfg -s -rF70**

## Editing VME Settings

To edit the changeable VME setting, type the following at the firmware prompt:

- Edits Master Enable state  
**vmeCfg -e -m**
- Edits selected Inbound Window state  
**vmeCfg -e -i(0 - 7)**
- Edits selected Outbound Window state  
**vmeCfg -e -o(0 - 7)**
- Edits PCI Miscellaneous Register state  
**vmeCfg -e -r184**
- Edits Special PCI Target Image Register state  
**vmeCfg -e -r188**
- Edits Master Control Register state  
**vmeCfg -e -r400**
- Edits Miscellaneous Control Register state  
**vmeCfg -e -r404**
- Edits User AM Codes Register state  
**vmeCfg -e -r40C**

- Edits VMEbus Register Access Image Control Register state

```
vmeCfg -e -rF70
```

## Deleting VME Settings

To delete the changeable VME setting (restore default value), type the following at the firmware prompt:

- Deletes Master Enable state  

```
vmeCfg -d -m
```
- Deletes selected Inbound Window state  

```
vmeCfg -d -i(0 - 7)
```
- Deletes selected Outbound Window state  

```
vmeCfg -d -o(0 - 7)
```
- Deletes PCI Miscellaneous Register state  

```
vmeCfg -d -r184
```
- Deletes Special PCI Target Image Register state  

```
vmeCfg -d -r188
```
- Deletes Master Control Register state  

```
vmeCfg -d -r400
```
- Deletes Miscellaneous Control Register state  

```
vmeCfg -d -r404
```
- Deletes User AM Codes Register state  

```
vmeCfg -d -r40C
```
- Deletes VMEbus Register Access Image Control Register state  

```
vmeCfg -d -rF70
```

## Restoring Default VME Settings

To restore all of the changeable VME setting back to their default settings, type the following at the firmware prompt:

```
vmeCfg -z
```

## Remote Start

As described in the *MOTLoad Firmware Package User's Manual*, listed in [Appendix B, Related Documentation](#), remote start allows the user to obtain information about the target board, download code and/or data, modify memory on the target, and execute a downloaded program. These transactions occur across the VMEbus in the case of the MVME3100. MOTLoad uses one of four mailboxes in the Tsi148 VME controller as the inter-board communication address (IBCA) between the host and the target.

CR/CSR slave addresses configured by MOTLoad are assigned according to the installation slot in the backplane, as indicated by the *VME64 Specification*. For reference, the following values are provided:

Slot Position	CS/CSR Starting Address
1	0x0008.0000
2	0x0010.0000
3	0x0018.0000
4	0x0020.0000
5	0x0028.0000
6	0x0030.0000
7	0x0038.0000
8	0x0040.0000
9	0x0048.0000
A	0x0050.0000
B	0x0058.0000
C	0x0060.0000

For further details on CR/CSR space, please refer to the *VME64 Specification*, listed in [Appendix B, Related Documentation](#).

The MVME3100 uses a TSi148 for its PCI/X-to-VME bus bridge. The offsets of the mailboxes in the TSi148 are defined in the *TSi148 VMEbus PCI/X-to-VME User Manual*, listed in [Appendix B, Related Documentation](#), but are noted here for reference:

Mailbox 0 is at offset 7f610 in the CR/CSR space  
 Mailbox 1 is at offset 7f614 in the CR/CSR space  
 Mailbox 2 is at offset 7f618 in the CR/CSR space  
 Mailbox 3 is at offset 7f61C in the CR/CSR space

The selection of the mailbox used by remote start on an individual MVME3100 is determined by the setting of a global environment variable (GEV). The default mailbox is zero. Another GEV controls whether remote start is enabled (default) or disabled. Refer to the *Remote Start* appendix in the MOTLoad Firmware Package User's Manual for remote start GEV definitions.

The MVME3100's IBCA needs to be mapped appropriately through the master's VMEbus bridge. For example, to use remote start using mailbox 0 on an MVME3100 installed in slot 5, the master would need a mapping to support reads and writes of address 0x002ff610 in VME CR/CSR space (0x280000 + 0x7f610).



## Alternate Boot Images and Safe Start

Some later versions of MOTLoad support Alternate Boot Images and a Safe Start recovery procedure. If Safe Start is available on the MVME3100, Alternate Boot Images are supported. With Alternate Boot Image support, the bootloader code in the boot block examines the upper 8MB of the flash bank for Alternate Boot images. If an image is found, control is passed to the image.

## Firmware Startup Sequence Following Reset

The firmware startup sequence following reset of MOTLoad is to:

- Initialize cache, MMU, FPU, and other CPU internal items
- Initialize the memory controller
- Search the active flash bank, possibly interactively, for a valid POST image. If found, the POST image executes. Once completed, the POST image returns and startup continues.
- Search the active flash bank, possibly interactively, for a valid USER boot image. If found, the USER boot image executes. A return to the boot block code is not anticipated.
- If a valid USER boot image is not found, search the active flash bank, possibly interactively, for a valid Alternate MOTLoad boot image; anticipated to be an upgrade of Alternate MOTLoad firmware. If found, the image is executed. A return to the boot block code is not anticipated.
- Execute the recovery image of the firmware in the boot block if no valid USER or alternate MOTLoad image is found

During startup, interactive mode may be entered by either setting the Safe Start jumper/switch or by sending an **<ESC>** to the console serial port within five seconds of the board reset. During interactive mode, the user has the option to display locations at which valid boot images were discovered, specify which discovered image is to be executed, or specify that the recovery image in the boot block of the active Flash bank is to be executed.

## Firmware Scan for Boot Image

The scan is performed by examining each 1MB boundary for a defined set of flags that identify the image as being Power On Self Test (POST), USER, or Alternate MOTLoad. POST is a user-developed Power On Self Test that would perform a set of diagnostics and then return to the bootloader image. USER would be a boot image, such as the VxWorks bootrom, which would perform board initialization. A bootable VxWorks kernel would also be a USER image. Boot images are not restricted to being MB or less in size; however, they must begin on a 1MB boundary within the 8MB of the scanned flash bank. The Flash Bank Structure is shown below:

Address	Usage
0xFFFF0000 to 0xFFFFFFFF	Boot block. Recovery code
0xFFE00000 to 0xFFFFFFFF	Reserved. (MOTLoad update image)
0xFFD00000 to 0xFFDFFFFFF	First possible alternate image (Bank B / Bank A actual)
0xFFC00000 to 0xFFCFFFFFF	Second possible alternate image (Bank B / Bank A actual)
....	Alternate boot images
0xFF899999 to 0xFF8FFFFFF	Bottom of Flash (Flash size varies per product)

The scan is performed downwards beginning at the location of the first possible alternate image and searches first for POST, then USER, and finally Alternate MOTLoad images. In the case of multiple images of the same type, control is passed to the first image encountered in the scan.

Safe Start, whether invoked by hitting **ESC** on the console within the first five seconds following power-on reset or by setting the Safe Start jumper, interrupts the scan process. The user may then display the available boot images and select the desired image. The feature is provided to enable recovery in cases when the programmed Alternate Boot Image is no longer desired. The following output is an example of an interactive Safe Start:

```
ABCDEInteractive Boot Mode Entered
boot> ?
Interactive boot commands:
'd':show directory of alternate boot images
'c':continue with normal startup
'q':quit without executing any alternate boot image
'r [address]':execute specified (or default) alternate image
'p [address]':execute specified (or default) POST image
'?:this help screen
'h':this help screen
boot> d
Addr FFE00000 Size 00100000 Flags 00000003 Name: MOTLoad
Addr FFD00000 Size 00100000 Flags 00000003 Name: MOTLoad
boot> c
NOPQRSTUVWXYZabcdefghijklmnopqrsstuvwxyzWXXZ
Copyright Motorola Inc. 1999-2004, All Rights Reserved
MOTLoad RTOS Version 2.0, PAL Version 0.b EA02
```

...

MVME3100&gt;

## Valid Boot Images

Valid boot images whether POST, USER, or Alternate MOTLoad, are located on 1MB boundaries within flash. The image may exceed 1MB in size. An image is determined valid through the presence of two "valid image keys" and other sanity checks. A valid boot image begins with a structure as defined in the following table:

Name	Type	Size	Notes
UserDefined	unsigned integer	8	User defined
ImageKey 1	unsigned integer	1	0x414c5420
ImageKey 2	unsigned integer	1	0x424f4f54
ImageChecksum	unsigned integer	1	Image checksum
ImageSize	unsigned integer	1	Must be a multiple of 4
ImageName	unsigned character	20	User defined
ImageRamAddress	unsigned integer	1	RAM address
ImageOffset	unsigned integer	1	Offset from header start to entry
ImageFlags	unsigned integer	1	Refer to <a href="#">MOTLoad Image Flags on page 32</a>
ImageVersion	unsigned integer	1	User defined
Reserved	unsigned integer	8	Reserved for expansion

## Checksum Algorithm

The checksum algorithm is a simple unsigned word add of each word (4 byte) location in the image. The image must be a multiple of 4 bytes in length (word-aligned). The content of the checksum location in the header is not part of the checksum calculation. The calculation assumes the location to be zero. The algorithm is implemented using the following code:

```
Unsigned int checksum(
    Unsigned int *startPtr, /* starting address */
    Unsigned int endPtr /* ending address */
) {
    unsigned int checksum=0;
    while (startPtr < endPtr) {
        checksum += *startPtr;
        startPtr++;
    }
    return(checksum);
}
```

## MOTLoad Image Flags

The image flags of the header define various bit options that control how the image will be executed.

**Table 3-2. MOTLoad Image Flags**

Name	Value	Interpretation
COPY_TO_RAM	0x00000001	Copy image to RAM at <b>ImageRamAddress</b> before execution
IMAGE_MCG	0x00000002	Alternate MOTLoad image
IMAGE_POST	0x00000004	POST image
DONT_AUTO_RUN	0x00000008	Image <i>not</i> to be executed

### COPY\_TO\_RAM

If set, this flag indicates that the image is to be copied to RAM at the address specified in the header before control is passed. If not set, the image will be executed in Flash. In both instances, control will be passed at the image offset specified in the header from the base of the image.

### IMAGE\_MCG

If set, this flag defines the image as being an Alternate MOTLoad, as opposed to USER, image. This bit should not be set by developers of alternate boot images.

### IMAGE\_POST

If set, this flag defines the image as being a power-on self-test image. This bit flag is used to indicate that the image is a diagnostic and should be run prior to running either USER or MCG boot images. POST images are expected, but not required, to return to the boot block code upon completion.

### DONT\_AUTO\_RUN

If set, this flag indicates that the image is not to be selected for automatic execution. A user, through the interactive command facility, may specify the image to be executed.

---

**Note** MOTLoad currently uses an Image Flag value of 0x3, which identifies itself as an Alternate MOTLoad image that executes from RAM. MOTLoad currently does not support execution from flash.

---

## USER Images

These images are user-developer boot code; for example, a VxWorks bootrom image. Such images may expect the system software state to be as follows upon entry:

- The MMU is disabled.
- L1 instruction cache has been initialized and is enabled.

- L1 data cache has been initialized (invalidated) and is disabled.
- L2 cache is disabled.
- L3 cache is disabled.
- RAM has been initialized and is mapped starting at CPU address 0.
- If RAM ECC or parity is supported, RAM has been scrubbed of ECC or parity errors.
- The active Flash bank (boot) is mapped from the upper end of the address space.
- If specified by COPY\_TO\_RAM, the image has been copied to RAM at the address specified by **ImageRamAddress**.
- CPU register R1 (the stack pointer) has been initialized to a value near the end of RAM.
- CPU register R3 is added to the following structure:

```
typedef struct altBootData {
    unsigned int ramSize; /* board's RAM size in MB */
    void flashPtr; /* ptr to this image in flash */
    char boardType[16]; /* name string, eg MVME3100 */
    void globalData; /* 16K, zeroed, user defined */
    unsigned int reserved[12];
} altBootData_t;
```

## Alternate Boot Data Structure

The globalData field of the alternate boot data structure points to an area of RAM which was initialized to zeroes by the boot loader. This area of RAM is not cleared by the boot loader after execution of a POST image, or other alternate boot image, is executed. It is intended to provide a user a mechanism to pass POST image results to subsequent boot images.

The boot loader performs no other initialization of the board than that specified prior to the transfer of control to either a POST, USER, or Alternate MOTLoad image. Alternate boot images need to initialize the board to whatever state the image may further require for its execution.

POST images are expected, but not required, to return to the boot loader. Upon return, the boot loader proceeds with the scan for an executable alternate boot image. POST images that return control to the boot loader must ensure that upon return, the state of the board is consistent with the state that the board was in at POST entry. USER images should not return control to the boot loader.



This chapter describes the MVME3100 and the MVME721 rear transition module (RTM) on a block diagram level.

## Features

The following tables list the features of the MVME3100 and its RTM.

**Table 4-1. MVME3100 Features Summary**

Feature	Description
Processor/Host Controller/Memory Controller	<ul style="list-style-type: none"> <li>– Single 833 MHz MPC8540 PowerQUICC III™ integrated processor (e500 core)</li> <li>– Integrated 256KB L2 cache/SRAM</li> <li>– Integrated four-channel DMA controller</li> <li>– Integrated PCI/PCI-X controller</li> <li>– Two integrated 10/100/1000 Ethernet controllers</li> <li>– Integrated 10/100 Ethernet controller</li> <li>– Integrated dual UART</li> <li>– Integrated I2C controller</li> <li>– Integrated programmable interrupt controller</li> <li>– Integrated local bus controller</li> <li>– Integrated DDR SDRAM controller</li> </ul>
System Memory	<ul style="list-style-type: none"> <li>– One SODIMM socket</li> <li>– Up to DDR333, ECC</li> <li>– One or two banks of memory on a single SODIMM</li> </ul>
I <sup>2</sup> C Interface	<ul style="list-style-type: none"> <li>– One 8KB VPD serial EEPROM</li> <li>– Two 64KB user configuration serial EEPROMs</li> <li>– One real-time clock (RTC) with removable battery</li> <li>– One temperature sensor</li> <li>– Interface to SPD(s) on SODIMM and P2 for RTM VPD</li> </ul>
Flash	<ul style="list-style-type: none"> <li>– 128MB soldered Flash with two alternate 1MB boot sectors selectable via a hardware switch</li> <li>– Hardware switch or software bit write protection for entire logical bank</li> </ul>

**Table 4-1. MVME3100 Features Summary (continued)**

Feature	Description
PCI Interface	Bus A: – 66 MHz PCI or PCI-X mode (switch selectable) – One TS148 VMEbus controller – One serial ATA (sATA) controller – One MPC8540 – Two PCI6520 PCI-X-to-PCI-X bridges (primary side)
	Bus B: – 33/66/100 MHz PCI/PCI-X (PCI 2.2 and PCI-X 1.0b compliant) – Two +3.3V/5V selectable VIO, 64-bit, single-wide PMC sites or one double-wide PMC site (PrPMC ANSI/VITA 32-2003 and PCI-X Auxiliary ANSI/VITA 39-2003 compliant) – One PCI6520 PCI-X-to-PCI-X bridge (secondary side)
	Bus C (-1263 version): – 33 MHz PCI (PCI 2.2 compliant) – One USB 2.0 controller – One PCI expansion connector for interface to PMCspan – One PCI6520 PCI-X-to-PCI-X bridge (secondary side)
I/O	– One front panel RJ45 connector with integrated LEDs for front I/O: one serial channel – One front panel RJ45 connector with integrated LEDs for front I/O: one 10/100/1000 Ethernet channel – One front panel external sATA data connector for front I/O: one sATA channel – One front panel USB Type A upright receptacle for front I/O: one USB 2.0 channel (-1263 version) – PMC site 1 front I/O and rear P2 I/O – PMC site 2 front I/O
Serial ATA	– One four-channel sATA controller: one channel for front-panel I/O, one channel for planar I/O, one channel for future rear P0 I/O, and one channel is not used – One planar data connector and one planar power connector for an interface to the sATA hard disk drive
USB (-1263 version)	– One four-channel USB 2.0 controller: one channel for front panel
Ethernet	– Two 10/100/1000 MPC8540 Ethernet channels for front-panel I/O and rear P2 I/O – One 10/100 MPC8540 Ethernet channel for rear P2 I/O
Serial Interface	– One 16550-compatible, 9.6 to 115.2 KBAUD, MPC8540, asynchronous serial channel for front-panel I/O – One quad UART controller to provide four 16550-compatible, 9.6 to 115.2 KBAUD, asynchronous serial channels for rear P2 I/O
Timers	– Four 32-bit MPC8540 timers – Four 32-bit timers in a PLD
Watchdog Timer	– One MPC8540 watchdog timer



**Table 4-1. MVME3100 Features Summary (continued)**

Feature	Description
VME Interface	<ul style="list-style-type: none"> <li>– VME64 (ANSI/VITA 1-1994) compliant</li> <li>– VME64 Extensions (ANSI/VITA 1.1-1997) compliant</li> <li>– 2eSST (ANSI/VITA 1.5-2003) compliant</li> <li>– VITA 41.0, version 0.9 compliant</li> <li>– Two five-row P1 and P2 backplane connectors</li> <li>– One TSi148 VMEbus controller</li> </ul>
Form Factor	<ul style="list-style-type: none"> <li>– Standard 6U VME</li> </ul>
Miscellaneous	<ul style="list-style-type: none"> <li>– One front-panel reset/abort switch</li> <li>– Four front-panel status indicators: 10/100/1000 Ethernet link/speed and activity, board fail, and user software controlled LED</li> <li>– Six planar status indicators: one power supply status LED, two user software controlled LEDs, three sATA activity LEDs (one per channel)</li> <li>– One standard 16-pin COP header</li> <li>– Boundary scan support</li> <li>– Switches for VME geographical addressing in a three-row backplane</li> </ul>
Software Support	<ul style="list-style-type: none"> <li>– VxWorks operating system</li> <li>– Linux operating system</li> </ul>

**Table 4-2. MVME721 RTM Features Summary**

Feature	Description
I/O	<ul style="list-style-type: none"> <li>– One five-row P2 backplane connector for serial and Ethernet I/O passed from the MVME3100</li> <li>– Four RJ-45 connectors for rear-panel I/O: four asynchronous serial channels</li> <li>– Two RJ-45 connectors with integrated LEDs for rear panel I/O: one 10/100/1000 Ethernet channel and one 10/100 Ethernet channel</li> <li>– One PIM site with rear-panel I/O</li> </ul>
Miscellaneous	<ul style="list-style-type: none"> <li>– Four status indicators: 10/100/1000 and 10/100 Ethernet link/speed and activity LEDs</li> </ul>

## Block Diagrams

Figure 4-1 shows a block diagram of the overall board architecture and Figure 4-2 shows a block diagram of the MVME721 rear transition module architecture.

Figure 4-1. MVME3100 Block Diagram

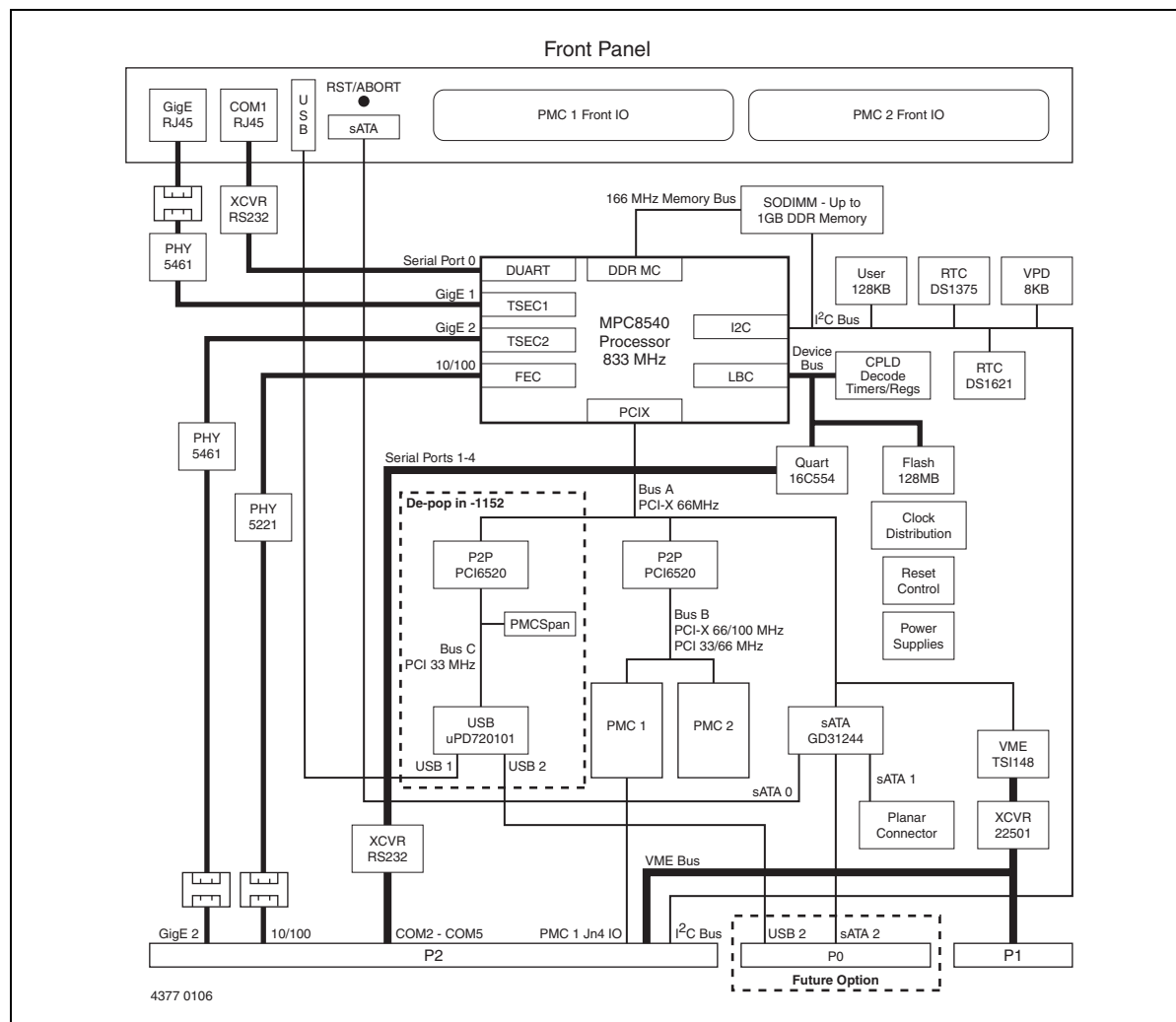
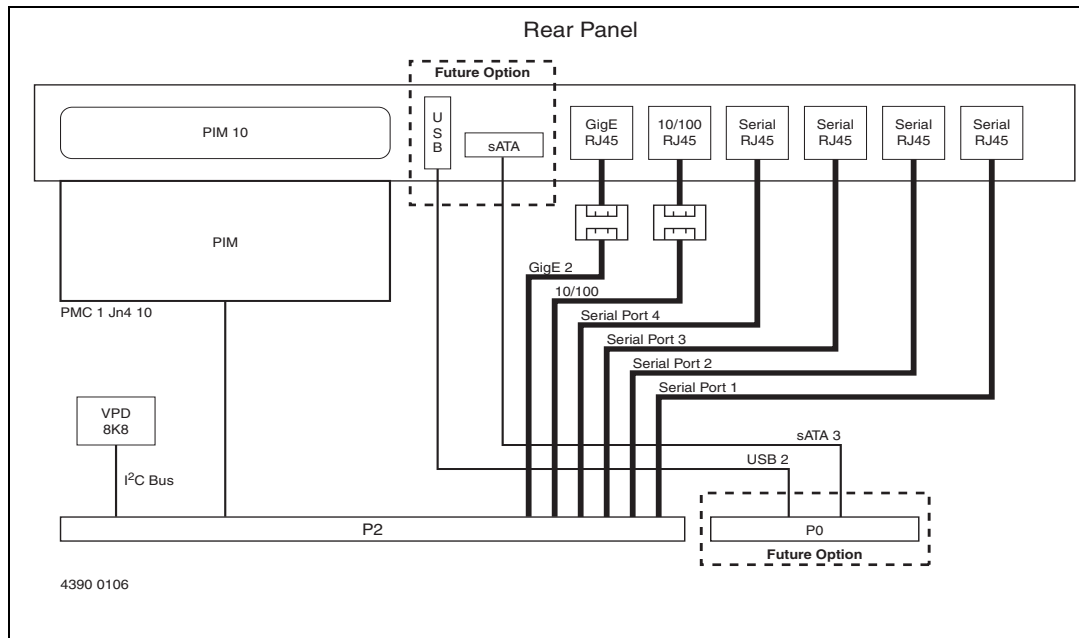

Figure 4-2. MVME721 RTM Block Diagram



## Processor

The MVME3100 supports the MPC8540 processor. The processor core frequency runs at 833 or 667 MHz. The MPC8540 has integrated 256KB L2 cache.

## System Memory

The MPC8540 provides one standard DDR SDRAM SODIMM socket. This socket supports standard single or dual bank, unbuffered, SSTL-2 DDR-I, JESD8-9B compliant, SODIMM module with ECC. The MPC8540 DDR memory interface supports up to 166 MHz (333 MHz data rate) operation.

## Local Bus Interface

The MVME3100 uses the MPC8540 local bus controller (LBC) for access to on-board Flash and I/O registers. The LBC has programmable timing modes to support devices of different access times, as well as device widths of 8, 16, and 32 bits.

The MVME3100 uses the LBC in GPCM (general purpose chip select machine) mode to interface to two physical banks of on-board Flash, an on-board quad UART (QUART), on-board 32-bit timers, and the System Control/Status registers. Refer to the MVME3100 Single-Board Computer Programmer's Reference Guide listed in [Appendix B, Related Documentation](#), for the LBC bank and chip select assignments.

## Flash Memory

The MVME3100 provides one physical bank of soldered-on Flash memory. The bank is composed of two physical Flash devices configured to operate in 16-bit mode to form a 32-bit Flash bank. The default configuration for the MVME3100-1263 is 128MB using two 512Mb devices, and for the MVME3100-1152 it is 64MB using two 256Mb devices.

Refer to the MVME3100 Single-Board Computer Programmer's Reference Guide listed in [Appendix B, Related Documentation](#), for more information.

## Control and Timers Logic

The MVME3100 control and timers logic resides on the local bus. This logic provides the following functions on the board:

- Local bus address latch
- Chip selects for Flash banks and QUART
- System Control and Status registers
- Four 32-bit tick timers
- Real-time clock (RTC) 1 MHz reference clock

Refer to the *MVME3100 Single-Board Computer Programmer's Reference Guide* listed in [Appendix B, Related Documentation](#), for more information.

## I<sup>2</sup>C Serial Interface and Devices

The MVME3100 provides the following on-board I2C serial devices connected to the MPC8540 I2C controller interface:

- 8KB serial EEPROM for VPD
- Two 64KB serial EEPROMs for user configuration data storage
- 256 byte serial EEPROM on SODIMM for SPD
- Maxim DS1375 RTC
- Maxim DS1621 temperature sensor
- 8KB serial EEPROM on RTM VPD

The Maxim DS1375 RTC implemented on the MVME3100 provides an alarm interrupt routed to the MPC8540 programmable interrupt controller (PIC). A Maxim DS32KHz temperature controlled crystal oscillator provides the RTC reference. A battery backup circuit for the RTC is provided on board.

The Maxim DS1621 digital temperature sensor provides a measure of the temperature of the board.

The I<sup>2</sup>C interface is also routed to the on-board SODIMM socket. This allows the serial presence detect (SPD) in the serial EEPROM, which is located on the memory module, to be read and used to configure the memory controller accordingly. Similarly, the I2C interface is routed to the P2 connector for access to the serial EEPROM located on the RTM. The device address for the RTM serial EEPROM is user-selectable using configuration switches on the RTM.

Refer to the *MVME3100 Single-Board Computer Programmer's Reference Guide* in [Appendix B, Related Documentation](#), for more information.

## Ethernet Interfaces

The MVME3100 provides one 10/100 and two 10/100/1000 Mb/s full duplex Ethernet interfaces using the MPC8540 Fast Ethernet Controller (FEC) and two Triple Speed Ethernet Controllers (TSEC). A Broadcom BCM5461S PHY is used for each TSEC interface, and each TSEC interface and PHY is configured to operate in GMII mode. One Gigabit Ethernet interface is routed to a front-panel RJ-45 connector with integrated LEDs for speed and activity indication. The other Gigabit Ethernet interface is routed to P2 for rear I/O.

A Broadcom BCM5221 PHY is used for the FEC interface. The Fast Ethernet interface is routed to P2 for rear I/O. Isolation transformers are provided on-board for each interface. The assigned PHY addresses for the MPC8540 MII management (MIIM) interface can be found in the *MVME3100 Single-Board Computer Programmer's Reference Guide*, listed in [Appendix B, Related Documentation](#).

Each Ethernet interface is assigned an Ethernet Station Address. The address is unique for each device. The Ethernet Station Addresses are displayed on labels attached to the PMC front-panel keep-out area.

## Asynchronous Serial Ports

The MVME3100 board contains one front-access asynchronous serial port interface using serial port 0 from the MPC8540 dual UART (DUART) device. This serial port is routed to the RJ-45 front-panel connector.

This board also contains one quad UART (QUART) device connected to the MPC8540 device controller bus to provide additional asynchronous serial ports. The QUART provides four asynchronous serial ports, SP1 – SP4, which are routed to the P2 connector. Refer to the *ST16C554D Datasheet* listed in [Appendix B, Related Documentation](#), for additional details and/or programming information.

## PCI/PCI-X Interfaces and Devices

The MVME3100 provides three separate PCI/PCI-X bus segments. Bus segment A operates in 66 MHz PCI or PCI-X mode and is connected to the MPC8540, the TSi148 VME controller, the serial ATA (sATA) controller, and two PCI-X-to-PCI-X bridges. Bus segment B is bridged between bus A and the two PMC sites and operates in 33/66 MHz PCI or 66/100 MHz PCI-X mode depending on the slowest speed PMC installed. Bus segment C is bridged between bus A, the USB controller, and the PMCspan connector. Bus C operates at 33 MHz PCI mode.

### MPC8540 PCI-X Interface

The MPC8540 PCI-X controller operates in PCI or PCI-X, host bridge mode depending on the state of the Bus A mode switch. The mode cannot be changed by software. Refer to the *MPC8540 Reference Manual* listed in [Appendix B, Related Documentation](#), for additional details and/or programming information.

### TSi148 VME Controller

The VMEbus interface for the MVME3100 is provided by the TSi148 ASIC. The TSi148 provides the required VME, VME extensions, and 2eSST functions. Transceivers are used to buffer the VME signals between the TSi148 and the VME backplane. Refer to the *TSi148 User's Manual* listed in [Appendix B, Related Documentation](#), for additional details and/or programming information.

### Serial ATA Host Controller

The sATA host controller uses the Intel GD31244 PCI-X to sATA controller. This device provides four sATA channels at 1.5Gb/s and is compliant with the *Serial ATA: High speed serialized AT Attachment Specification, Revision 1.0e*. It also supports the native command queuing feature of SATA II.

The MVME3100 uses two of the four sATA channels. Channel 0 is routed to a sATA connector mounted on the front panel for an external drive connection. Channel 1 is routed to a planar sATA connector for an "inside the chassis" drive connection. Colocated with the planar connector is a sATA power connector. At power-up, the controller is configured to operate in either legacy (Native PCI IDE) mode or Direct Port Access (DPA) mode, controlled by the sATA mode switch. The mode cannot be changed by software.

The MVME3100 provides two LEDs to indicate sATA channel activity. The function of the LEDs depends on the operating mode of the 31244 (legacy or DPA mode).

Refer to the 31244 PCI-X to Serial ATA Controller Datasheet and 31244 PCI-X to Serial ATA Controller Specification Update listed in [Appendix B, Related Documentation](#), for additional details and/or programming information

## PCI-X-to-PCI-X Bridges

The MVME3100 uses two PLX PCI6520 PCI-X-to-PCI-X bridges to isolate the primary PCI bus, bus A. These bridges isolate bus A from bus B with the PMC sites and from bus C with the USB controller and PMCspan interface. The PCI6520 is a 64-bit, 133 MHz, PCI-X r1.0b compliant device. It operates asynchronously between 33 MHz and 133 MHz on either primary or secondary port. Refer to the *PCI6520CB Data Book* listed in [Appendix B, Related Documentation](#), for additional details and/or programming information.

## PCI Mezzanine Card Slots

The MVME3100 provides two PMC sites that support standard PMCs or PrPMCs. Both PMC sites are located on PCI bus B and operate at the same speed and mode as determined by the slowest PMC module. The board routing supports a maximum of 100 MHz PCI-X operation on each site. Signaling voltage ( $V_{io}$ ) for the two PMC sites is dependent on keying pin installation options and can be configured for 5V or 3.3V. *Both sites must be configured for the same  $V_{io}$  voltage or the  $V_{io}$  voltage will be disabled.* Each PMC site has enough 3.3V and 5V power allocated to support a 25 watt (max) PMC or PrPMC from either supply.

PMC slot 1 supports:

<b>Mezzanine Type:</b>	PMC = PCI Mezzanine Card
<b>Mezzanine Size:</b>	S1B = Single width and standard depth (75mm x 150mm) with front panel
<b>PMC Connectors:</b>	J11, J12, J13, and J14 (32/64-bit PCI with front and rear I/O)
<b>Signaling Voltage:</b>	$V_{IO} = +3.3V$ (+5V tolerant) or +5V, selected by keying pin

PMC slot 2 supports:

<b>Mezzanine Type:</b>	PMC = PCI Mezzanine Card
<b>Mezzanine Size:</b>	S1B = Single width and standard depth (75mm x 150mm) with front panel
<b>PMC Connectors:</b>	J21, J22, and J23 (32/64-bit PCI with front I/O)
<b>Signalling Voltage:</b>	$V_{IO} = +3.3V$ (+5V tolerant) or +5V, selected by keying pin

**Note** You cannot use 3.3V and 5V PMCs together; the voltage keying pin on slots 1 and 2 must be identical. When in 5V mode, the bus runs at 33 MHz.

In addition, the PMC connectors are located such that a double-width PMC may be installed in place of the two single-width PMCs.

In this case, the MVME3100 supports:

<b>Mezzanine Type:</b>	PMC = PCI Mezzanine Card
<b>Mezzanine Size:</b>	Double width and standard depth (150mm x 150mm) with front panel
<b>PMC Connectors:</b>	J11, J12, J13, J14, J21, J22, and J23 (32/64-bit PCI with front and rear I/O) on J14 only
<b>Signaling Voltage:</b>	VIO = +3.3V (+5V tolerant) or +5V, selected by keying pin

**Note** On PMC site 1, the user I/O – J14 signals will only support the low-current, high-speed signals and are not to be used for any current bearing power supply usage. The maximum current rating of each pin/signal is 100 mA.

## USB

The USB 2.0 host controller provides USB ports with integrated transceivers for connectivity with any USB-compliant device or hub. USB channel 1 is routed to a single USB connector located at the front panel. DC power to the front panel USB port is supplied via a USB power switch, which provides soft-start, current limiting, over-current detection, and power enable for port 1. Refer to the *μPD720101 USB 2.0 Host Controller Datasheet* listed in [Appendix B, Related Documentation](#), for additional details.

## PMC Expansion

The MVM3E3100 provides additional PMC module capability through the use of a connector on bus C that is compatible with the PMCspan boards. Up to four additional PMC modules may be added by using existing PMCspan boards. Refer to the *PMCspan PMC Adapter Carrier Board Installation and Use* manual listed in [Appendix B, Related Documentation](#), for additional details.

## General-Purpose Timers

There are a total of eight independent, 32-bit timers. Four timers are integrated into the MPC8540 and four timers are in the PLD. The four MPC8540 timers are clocked by the RTC input, which is driven by a 1 MHz clock. The clock source for the four timers in the PLD is 25 MHz. Refer to the *MPC8540 Reference Manual* listed in [Appendix B, Related Documentation](#), for additional details and/or programming information.

## Real-time Clock Battery

There is an on-board Renata SMT battery holder on the MVME3100. This SMTU2430-1 holder allows for quick and easy replacement of a 3V button cell lithium battery (CR2430), which provides back-up power to the on-board DS1375 RTC. A battery switching circuit provides automatic switching between the 3.3V and battery voltages. The battery provides backup power to the RTC for a minimum of one year at nominal temperature.



## Reset Control Logic

The sources of reset on the MVME3100 are the following:

- Power-up
- Reset switch
- Watchdog timer
- System Control register bit
- VMEbus reset

A board-level hard reset generates a reset for the entire board including the MPC8540, local PCI/PCI-X buses, Ethernet PHYs, serial ports, Flash devices, and PLD(s). If the MVME3100 is configured as the VME system controller, the VME bus and local TSi148 reset input are also reset.

## Debug Support

The MVME3100 provides a boundary scan header for boundary scan test access and device programming. This board also provides a separate standard COP header for MPC8540 COP emulation.

## Introduction

This chapter provides pin assignments for various connectors and headers on the MMVE3100 single-board computer and the MVME721 transition module.

- *PMC Expansion Connector (J4)*
- *Ethernet Connectors (GENET1/J41B, GENET2/J2B, ENET1/J2A)*
- *PCI Mezzanine Card (PMC) Connectors (J11 – J14, J21 – J23)*
- *Serial Port Connectors (COM1/J41A, COM2–COM5/J2A–D)*
- *VMEbus P1 Connector*
- *VMEbus P2 Connector*
- *MVME721 PMC I/O Module (PIM) Connectors (J10, J14)*
- *Planar sATA Power Connector (J30)*
- *USB Connector (J27)*
- *sATA Connectors (J28 and J29)*

The following headers are described in this chapter:

- *Boundary Scan Header (J24)*
- *Processor COP Header (J25)*

## Connectors

### PMC Expansion Connector (J4)

One 114-pin Mictor connector with a center row of power and ground pins is used to provide PCI expansion capability. The pin assignments for this connector are as follows:

**Table 5-1. PMC Expansion Connector (J4)  
Pin Assignments**

Pin	Signal		Signal	Pin
1	+3.3V	GND	+3.3V	2
3	PCICLK		PMCINTA#	4
5	GND		PMCINTB#	6
7	PURST#		PMCINTC#	8
9	HRESET#		PMCINTD#	10
11	TDO		TDI	12
13	TMS		TCK	14
15	TRST#		PEP#	16
17	PCIXGNT#		PCIXREQ#	18
19	+12V		-12V	20
21	PERR#		SERR#	22
23	LOCK#		No Connect	24
25	DEVSEL#		No Connect	26
27	GND		PCI XCAP	28
29	TRDY#		IRDY#	30
31	STOP#		FRAME#	32
33	GND		M66EN	34
35	ACK64#		No Connect	36
37	REQ64#		No Connect	38

**Table 5-1. PMC Expansion Connector (J4)  
Pin Assignments (continued)**

Pin	Signal		Signal	Pin
39	PAR	+5V	PCIRST#	40
41	C/BE1#		C/BE0#	42
43	C/BE3#		C/BE2#	44
45	AD1		AD0	46
47	AD3		AD2	48
49	AD5		AD4	50
51	AD7		AD6	52
53	AD9		AD8	54
55	AD11		AD10	56
57	AD13		AD12	58
59	AD15		AD14	60
61	AD17		AD16	62
63	AD19		AD18	64
65	AD21		AD20	66
67	AD23		AD22	68
69	AD25		AD24	70
71	AD27		AD26	72
73	AD29	AD28	74	
75	AD31	AD30	76	

**Table 5-1. PMC Expansion Connector (J4)  
Pin Assignments (continued)**

Pin	Signal		Signal	Pin
77	PAR64	GND	No Connect	78
79	C/BE5#		C/BE4#	80
81	C/BE7#		C/BE6#	82
83	AD33		AD32	84
85	AD35		AD34	86
87	AD37		AD36	88
89	AD39		AD38	90
91	AD41		AD40	92
93	AD43		AD42	94
95	AD45		AD44	96
97	AD47		AD46	98
99	AD49		AD48	100
101	AD51		AD50	102
103	AD53		AD52	104
105	AD55		AD54	106
107	AD57		AD56	108
109	AD59		AD58	110
111	AD61	AD60	112	
113	AD63	AD62	114	

All PMC expansion signals are shared with the USB controller.

## Ethernet Connectors (GENET1/J41B, GENET2/J2B, ENET1/J2A)

There is one 10/100 and two 10/100/1000Mb/s full duplex Ethernet interfaces using the MPC8540 Fast Ethernet Controller (FEC) and two Triple Speed Ethernet Controllers (TSEC). One Gigabit Ethernet interface is routed to a front-panel RJ-45 connector with integrated LEDs for speed and activity indication. The other Gigabit Ethernet interface and the 10/100 interface are routed to P2 for rear I/O. The pin assignments for these connectors are as follows:

**Table 5-2. Ethernet Connectors Pin Assignment**

Pin #	Signal	1000 Mb/s	10/100 Mb/s
1	MDIO0+	_DA+	TD+
2	MDIO0-	_DA-	TD-
3	MDIO1+	_DB+	RD+
4	MDIO1-	_DC+	Not Used

**Table 5-2. Ethernet Connectors Pin Assignment (continued)**

Pin #	Signal	1000 Mb/s	10/100 Mb/s
5	MDIO2+	_DC-	Not Used
6	MDIO2-	_DB-	RD-
7	MDIO3+	_DD+	Not Used
8	MDIO3-	_DD-	Not Used

## PCI Mezzanine Card (PMC) Connectors (J11 – J14, J21 – J23)

There are seven 64-pin SMT connectors on the MVME3100 to provide 32/64-bit PCI interfaces and P2 I/O for one optional add-on PMC.

**Note** PMC slot connector J14 contains the signals that go to VME P2 I/O rows A, C, D, and Z.

The pin assignments for these connectors are as follows.

**Table 5-3. PMC Slot 1 Connector (J11)  
Pin Assignments**

Pin	Signal	Signal	Pin
1	TCK	-12V	2
3	GND	INTA#	4
5	INTB#	INTC#	6
7	PMCPRSNT1#	+5V	8
9	INTD#	PCI_RSVD	10
11	GND	+3.3Vaux	12
13	CLK	GND	14
15	GND	PMCGNT1#	16
17	PMCREQ1#	+5V	18
19	+3.3V (VIO)	AD31	20
21	AD28	AD27	22
23	AD25	GND	24
25	GND	C/BE3#	26
27	AD22	AD21	28
29	AD19	+5V	30
31	+3.3V (VIO)	AD17	32
33	FRAME#	GND	34
35	GND	IRDY#	36
37	DEVSEL#	+5V	38
39	GND	LOCK#	40

**Table 5-3. PMC Slot 1 Connector (J11)  
Pin Assignments (continued)**

Pin	Signal	Signal	Pin
41	PCI_RSVD	PCI_RSVD	42
43	PAR	GND	44
45	+3.3V (VIO)	AD15	46
47	AD12	AD11	48
49	AD09	+5V	50
51	GND	C/BE0#	52
53	AD06	AD05	54
55	AD04	GND	56
57	+3.3V (VIO)	AD03	58
59	AD02	AD01	60
61	AD00	+5V	62
63	GND	REQ64#	64

**Table 5-4. PMC Slot 1 Connector (J12)  
Pin Assignments**

Pin	Signal	Signal	Pin
1	+12V	TRST#	2
3	TMS	TDO	4
5	TDI	GND	6
7	GND	Not Used	8
9	Not Used	Not Used	10
11	Pull-up	+3.3V	12
13	RST#	Pull-down	14
15	+3.3V	Pull-down	16
17	Not Used	GND	18
19	AD30	AD29	20
21	GND	AD26	22
23	AD24	+3.3V	24
25	IDSEL1	AD23	26
27	+3.3V	AD20	28
29	AD18	GND	30
31	AD16	C/BE2#	32
33	GND	IDSEL1B	34
35	TRDY#	+3.3V	36
37	GND	STOP#	38

**Table 5-4. PMC Slot 1 Connector (J12)  
Pin Assignments (continued)**

Pin	Signal	Signal	Pin
39	PERR#	GND	40
41	+3.3V	SERR#	42
43	C/BE1#	GND	44
45	AD14	AD13	46
47	M66EN	AD10	48
49	AD08	+3.3V	50
51	AD07	REQ1B#	52
53	+3.3V	GNT1B#	54
55	Not Used	GND	56
57	Not Used	EREADY0	58
59	GND	Not Used	60
61	ACK64#	+3.3V	62
63	GND	No Connect (MONARCH#)	64

**Table 5-5. PMC Slot 1 Connector (J13)  
Pin Assignments**

Pin	Signal	Signal	Pin
1	Reserved	GND	2
3	GND	C/BE7#	4
5	C/BE6#	C/BE5#	6
7	C/BE4#	GND	8
9	+3.3V (VIO)	PAR64	10
11	AD63	AD62	12
13	AD61	GND	14
15	GND	AD60	16
17	AD59	AD58	18
19	AD57	GND	20
21	+3.3V (VIO)	AD56	22
23	AD55	AD54	24
25	AD53	GND	26
27	GND	AD52	28
29	AD51	AD50	30
31	AD49	GND	32
33	GND	AD48	34
35	AD47	AD46	36



**Table 5-5. PMC Slot 1 Connector (J13)  
Pin Assignments (continued)**

Pin	Signal	Signal	Pin
37	AD45	GND	38
39	+3.3V (VIO)	AD44	40
41	AD43	AD42	42
43	AD41	GND	44
45	GND	AD40	46
47	AD39	AD38	48
49	AD37	GND	50
51	GND	AD36	52
53	AD35	AD34	54
55	AD33	GND	56
57	+3.3V (VIO)	AD32	58
59	Reserved	Reserved	60
61	Reserved	GND	62
63	GND	Reserved	64

**Table 5-6. PMC Slot 1 Connector (J14)  
Pin Assignments**

Pin	Signal	Signal	Pin
1	PMC1_1 (P2-C1)	PMC1_2 (P2-A1)	2
3	PMC1_3 (P2-C2)	PMC1_4 (P2-A2)	4
5	PMC1_5 (P2-C3)	PMC1_6 (P2-A3)	6
7	PMC1_7 (P2-C4)	PMC1_8 (P2-A4)	8
9	PMC1_9 (P2-C5)	PMC1_10 (P2-A5)	10
11	PMC1_11 (P2-C6)	PMC1_12 (P2-A6)	12
13	PMC1_13 (P2-C7)	PMC1_14 (P2-A7)	14
15	PMC1_15 (P2-C8)	PMC1_16 (P2-A8)	16
17	PMC1_17 (P2-C9)	PMC1_18 (P2-A9)	18
19	PMC1_19 (P2-C10)	PMC1_20 (P2-A10)	20
21	PMC1_21 (P2-C11)	PMC1_22 (P2-A11)	22
23	PMC1_23 (P2-C12)	PMC1_24 (P2-A12)	24
25	PMC1_25 (P2-C13)	PMC1_26 (P2-A13)	26
27	PMC1_27 (P2-C14)	PMC1_28 (P2-A14)	28
29	PMC1_29 (P2-C15)	PMC1_30 (P2-A15)	30
31	PMC1_31 (P2-C16)	PMC1_32 (P2-A16)	32
33	PMC1_33 (P2-C17)	PMC1_34 (P2-A17)	34

**Table 5-6. PMC Slot 1 Connector (J14)  
Pin Assignments (continued)**

Pin	Signal	Signal	Pin
35	PMC1_35 (P2-C18)	PMC1_36 (P2-A18)	36
37	PMC1_37 (P2-C19)	PMC1_38 (P2-A19)	38
39	PMC1_39 (P2-C20)	PMC1_40 (P2-A20)	40
41	PMC1_41 (P2-C21)	PMC1_42 (P2-A21)	42
43	PMC1_43 (P2-C22)	PMC1_44 (P2-A22)	44
45	PMC1_45 (P2-C23)	PMC1_46 (P2-A23)	46
47	PMC1_47 (P2-C24)	PMC1_48 (P2-A24)	48
49	PMC1_49 (P2-C25)	PMC1_50 (P2-A25)	50
51	PMC1_51 (P2-C26)	PMC1_52 (P2-A26)	52
53	PMC1_53 (P2-C27)	PMC1_54 (P2-A27)	54
55	PMC1_55 (P2-C28)	PMC1_56 (P2-A28)	56
57	PMC1_57 (P2-C29)	PMC1_58 (P2-A29)	58
59	PMC1_59 (P2-C30)	PMC1_60 (P2-A30)	60
61	PMC1_61 (P2-C31)	PMC1_62 (P2-A31)	62
63	PMC1_63 (P2-C32)	PMC1_64 (P2-A32)	64

**Table 5-7. PMC Slot 2 Connector (J21)  
Pin Assignments**

Pin	Signal	Signal	Pin
1	TCK	-12V	2
3	GND	INTC#	4
5	INTD#	INTA#	6
7	PMCPRSNT1#	+5V	8
9	INTB#	PCI_RSVD	10
11	GND	+3.3Vaux	12
13	CLK	GND	14
15	GND	PMCGNT1#	16
17	PMCREQ1#	+5V	18
19	+3.3V (VIO)	AD31	20
21	AD28	AD27	22
23	AD25	GND	24
25	GND	C/BE3#	26
27	AD22	AD21	28
29	AD19	+5V	30
31	+3.3V (VIO)	AD17	32

**Table 5-7. PMC Slot 2 Connector (J21)  
Pin Assignments (continued)**

Pin	Signal	Signal	Pin
33	FRAME#	GND	34
35	GND	IRDY#	36
37	DEVSEL#	+5V	38
39	GND	LOCK#	40
41	PCI_RSVD	PCI_RSVD	42
43	PAR	GND	44
45	+3.3V (VIO)	AD15	46
47	AD12	AD11	48
49	AD09	+5V	50
51	GND	C/BE0#	52
53	AD06	AD05	54
55	AD04	GND	56
57	+3.3V (VIO)	AD03	58
59	AD02	AD01	60
61	AD00	+5V	62
63	GND	REQ64#	64

**Table 5-8. PMC Slot 2 Connector (J22)  
Pin Assignments**

Pin	Signal	Signal	Pin
1	+12V	TRST#	2
3	TMS	TDO	4
5	TDI	GND	6
7	GND	Not Used	8
9	Not Used	Not Used	10
11	Pull-up	+3.3V	12
13	RST#	Pull-down	14
15	+3.3V	Pull-down	16
17	Not Used	GND	18
19	AD30	AD29	20
21	GND	AD26	22
23	AD24	+3.3V	24
25	IDSEL1	AD23	26
27	+3.3V	AD20	28
29	AD18	GND	30

**Table 5-8. PMC Slot 2 Connector (J22)  
Pin Assignments (continued)**

Pin	Signal	Signal	Pin
31	AD16	C/BE2#	32
33	GND	IDSEL1B	34
35	TRDY#	+3.3V	36
37	GND	STOP#	38
39	PERR#	GND	40
41	+3.3V	SERR#	42
43	C/BE1#	GND	44
45	AD14	AD13	46
47	M66EN	AD10	48
49	AD08	+3.3V	50
51	AD07	REQ1B#	52
53	+3.3V	GNT1B#	54
55	Not Used	GND	56
57	Not Used	EREADY1	58
59	GND	Not Used	60
61	ACK64#	+3.3V	62
63	GND	No Connect (MONARCH#)	64

**Table 5-9. PMC Slot 2 Connector (J23)  
Pin Assignments**

Pin	Signal	Signal	Pin
1	Reserved	GND	2
3	GND	C/BE7#	4
5	C/BE6#	C/BE5#	6
7	C/BE4#	GND	8
9	+3.3V (VIO)	PAR64	10
11	AD63	AD62	12
13	AD61	GND	14
15	GND	AD60	16
17	AD59	AD58	18
19	AD57	GND	20
21	+3.3V (VIO)	AD56	22
23	AD55	AD54	24
25	AD53	GND	26
27	GND	AD52	28

**Table 5-9. PMC Slot 2 Connector (J23)  
Pin Assignments (continued)**

Pin	Signal	Signal	Pin
29	AD51	AD50	30
31	AD49	GND	32
33	GND	AD48	34
35	AD47	AD46	36
37	AD45	GND	38
39	+3.3V (VIO)	AD44	40
41	AD43	AD42	42
43	AD41	GND	44
45	GND	AD40	46
47	AD39	AD38	48
49	AD37	GND	50
51	GND	AD36	52
53	AD35	AD34	54
55	AD33	GND	56
57	+3.3V (VIO)	AD32	58
59	Reserved	Reserved	60
61	Reserved	GND	62
63	GND	Reserved	64

**Serial Port Connectors (COM1/J41A, COM2–COM5/J2A-D)**

There is one front access asynchronous serial port interface (SP0) that is routed to the RJ-45 front-panel connector. There are four asynchronous serial port interfaces, SP1 – SP4, which are routed to the P2 connector. The pin assignments for these connectors are as follows:

**Table 5-10. COM Port Connector Pin Assignments**

Pin	Signal
1	No connect
2	RTS
3	GND
4	TX
5	RX
6	GND
7	CTS
8	No connect

## VMEbus P1 Connector

The VME P1 connector is a 160-pin DIN. The P1 connector provides power and VME signals for 24-bit address and 16-bit data. The pin assignments for the P1 connector is as follows:

**Table 5-11. VMEbus P1 Connector Pin Assignments**

	ROW Z	ROW A	ROW B	ROW C	ROW D	
1	Reserved	D00	BBSY*	D08	+5V	1
2	GND	D01	BCLR*	D09	GND	2
3	Reserved	D02	ACFAIL*	D10	Reserved	3
4	GND	D03	BG0IN*	D11	Reserved	4
5	Reserved	D04	BG0OUT*	D12	Reserved	5
6	GND	D05	BG1IN*	D13	Reserved	6
7	Reserved	D06	BG1OUT*	D14	Reserved	7
8	GND	D07	BG2IN*	D15	Reserved	8
9	Reserved	GND	BG2OUT*	GND	GAP_L	9
10	GND	SYSCLK	BG3IN*	SYSFAIL*	GA0_L	10
11	Reserved	GND	BG3OUT*	BERR*	GA1_L	11
12	GND	DS1*	BR0*	SYSRESET*	Reserved	12
13	Reserved	DS0*	BR1*	LWORD*	GA2_L	13
14	GND	WRITE*	BR2*	AM5	Reserved	14
15	Reserved	GND	BR3*	A23	GA3_L	15
16	GND	DTACK*	AM0	A22	Reserved	16
17	Reserved	GND	AM1	A21	GA4_L	17
18	GND	AS*	AM2	A20	Reserved	18
19	Reserved	GND	AM3	A19	Reserved	19
20	GND	IACK*	GND	A18	Reserved	20
21	Reserved	IACKIN*	SERA	A17	Reserved	21
22	GND	IACKOUT*	SERB	A16	Reserved	22
23	Reserved	AM4	GND	A15	Reserved	23
24	GND	A07	IRQ7*	A14	Reserved	24
25	Reserved	A06	IRQ6*	A13	Reserved	25
26	GND	A05	IRQ5*	A12	Reserved	26
27	Reserved	A04	IRQ4*	A11	Reserved	27
28	GND	A03	IRQ3*	A10	Reserved	28
29	Reserved	A02	IRQ2*	A09	Reserved	29
30	GND	A01	IRQ1*	A08	Reserved	30
31	Reserved	-12V	+5VSTDBY	+12V	GND	31
32	GND	+5V	+5V	+5V	+5V	32

## VMEbus P2 Connector

The VME P2 connector is a 160-pin DIN. Row B of the P2 connector provides power to the MVME3100 and to the upper eight VMEbus address lines and additional 16 VMEbus data lines. The pin assignments for the P2 connector are the same for both the MVME3100 and MVME721, and are as follows:

**Table 5-12. VME P2 Connector Pinouts**

Pin	P2-Z	P2-A	P2-B	P2-C	P2-D
1	SP1RX	PMC1_IO2	+5V	PMC1_IO1	E1-1+
2	GND	PMC1_IO4	GND	PMC1_IO3	E1-1-
3	SP1TX	PMC1_IO6	VRETRY_L	PMC1_IO5	GND
4	GND	PMC1_IO8	VA24	PMC1_IO7	E1-2+
5	SP1CTS	PMC1_IO10	VA25	PMC1_IO9	E1-2-
6	GND	PMC1_IO12	VA26	PMC1_IO11	GND
7	SP1RTS	PMC1_IO14	VA27	PMC1_IO13	NC
8	GND	PMC1_IO16	VA28	PMC1_IO15	NC
9	SP2RX	PMC1_IO18	VA29	PMC1_IO17	GND
10	GND	PMC1_IO20	VA30	PMC1_IO19	NC
11	SP2TX	PMC1_IO22	VA31	PMC1_IO21	NC
12	GND	PMC1_IO24	GND	PMC1_IO23	GND
13	SP2CTS	PMC1_IO26	+5V	PMC1_IO25	I2C_SDA
14	GND	PMC1_IO28	VD16	PMC1_IO27	I2C_SCL
15	SP2RTS	PMC1_IO30	VD17	PMC1_IO29	E1_LINK
16	GND	PMC1_IO32	VD18	PMC1_IO31	E1_ACT
17	SP3RX	PMC1_IO34	VD19	PMC1_IO33	E2_LINK
18	GND	PMC1_IO36	VD20	PMC1_IO35	E2_ACT
19	SP3TX	PMC1_IO38	VD21	PMC1_IO37	GND
20	GND	PMC1_IO40	VD22	PMC1_IO39	E2-4-
21	SP3CTS	PMC1_IO42	VD23	PMC1_IO41	E2-4+
22	GND	PMC1_IO44	GND	PMC1_IO43	GND
23	SP3RTS	PMC1_IO46	VD24	PMC1_IO45	E2-3-
24	GND	PMC1_IO48	VD25	PMC1_IO47	E2-3+
25	SP4RX	PMC1_IO50	VD26	PMC1_IO49	GND
26	GND	PMC1_IO52	VD27	PMC1_IO51	E2-2-
27	SP4TX	PMC1_IO54	VD28	PMC1_IO53	E2-2+
28	GND	PMC1_IO56	VD29	PMC1_IO55	GND

**Table 5-12. VME P2 Connector Pinouts (continued)**

Pin	P2-Z	P2-A	P2-B	P2-C	P2-D
29	SP4CTS	PMC1_IO58	VD30	PMC1_IO57	E2-1-
30	GND	PMC1_IO60	VD31	PMC1_IO59	E2-1+
31	SP4RTS	PMC1_IO62	GND	PMC1_IO61	GND
32	GND	PMC1_IO64	+5V	PMC1_IO63	+5V

## MVME721 PMC I/O Module (PIM) Connectors (J10, J14)

PMC Host I/O connector J10 routes only power and ground from VME P2. There are no Host I/O signals on this connector. The MVME3100 routes PMC I/O from J14 of PMC Slot 1 to VME P2 rows A and C. The MVME721 routes these signals (pin-for-pin) from VME P2 to PMC I/O Module connector J14. See [Table 5-13](#) and [Table 5-6](#) for the pin assignments.

**Table 5-13. MVME721 Host I/O Connector (J10) Pin Assignments**

1	No Connect	No Connect	2
3	No Connect	No Connect	4
5	+5V	No Connect	6
7	No Connect	No Connect	8
9	No Connect	+3.3V	10
11	No Connect	No Connect	12
13	GND	No Connect	14
15	No Connect	No Connect	16
17	No Connect	GND	18
19	No Connect	No Connect	20
21	+5V	No Connect	22
23	No Connect	No Connect	24
25	No Connect	+3.3V	26
27	No Connect	No Connect	28
29	GND	No Connect	30
31	No Connect	No Connect	32
33	No Connect	GND	34
35	No Connect	No Connect	36
37	+5V	No Connect	38
39	No Connect	No Connect	40
41	No Connect	+3.3V	42
43	No Connect	No Connect	44
45	GND	No Connect	46
47	No Connect	No Connect	48



**Table 5-13. MVME721 Host I/O Connector (J10) Pin Assignments**

49	No Connect	GND	50
51	No Connect	No Connect	52
53	+5V	No Connect	54
55	No Connect	No Connect	56
57	No Connect	+3.3V	58
59	No Connect	No Connect	60
61	No Connect	No Connect	62
63	No Connect	No Connect	64

### Planar sATA Power Connector (J30)

There is one 2mm pitch header installed as a planar header on the MVME3100 board to provide power to a serial ATA (sATA) drive mounted on the board or somewhere within the chassis. The pin assignments for this header are as follows:

**Table 5-14. Planar sATA Power Connector (J30) Pin Assignments**

Pin	Signal
1	+5V
2	+5V
3	GND
4	GND

### USB Connector (J27)

There is one USB Type A connector located on the MVME3100 front panel. The pin assignments are as follows:

**Table 5-15. USB Connector (J27) Pin Assignments**

Pin	Signal
1	USB_VBUS (+5.0V)
2	USB_DATA-
3	USB_DATA+
4	GND

## sATA Connectors (J28 and J29)

The MVME3100 has two sATA connectors. J28 is an internal type sATA connector located on the planar and is intended to connect to a drive located on the board or somewhere inside the chassis. J29 is an external type sATA connected located on the front panel and is intended to connect to an external sATA drive. The pin assignment for these connectors is as follows:

**Table 5-16. sATA Connectors (J28 and J29) Pin Assignments**

Pin	Signal
1	GND
2	SATA_TX+
3	SATA_TX-
4	GND
5	SATA_RX-
6	SATA_RX+
7	GND

## Headers

### Boundary Scan Header (J24)

The 14-pin boundary scan header provides an interface for programming the on-board PLDs and for boundary scan testing/debug purposes. The pin assignments for this header are as follows:

**Table 5-17. Boundary Scan Header (J24) Pin Assignments**

Pin	Signal	Signal	Pin
1	TRST_L	GND	2
3	TDO	GND	4
5	TDI	GND	6
7	TMS	GND	8
9	TCK	GND	10
11	NC	GND (BSCANEN_L)	12
13	BSCAN_AW_L	GND	14

**Note** Pin 12 must be grounded in the cable in order to enable boundary scan.

## Processor COP Header (J25)

There is one standard 16-pin header that provides access to the COP function. The pin assignments for this header are as follows:

**Table 5-18. Processor COP Header (J25) Pin Assignments**

Pin	Signal	Signal	Pin
1	CPU_TDO	No Connect	2
3	CPU_TDI	CPU_TRST_L	4
5	Pullup	CPU_VIO (+3.3V)	6
7	CPU_TCK	CPU_CKSTPI_L	8
9	CPU_TMS	No Connect	10
11	CPU_SRST_L	GND (optional pull-down)	12
13	CPU_HRST_L	KEY (no pin)	14
15	CPU_CKSTPO_L	GND	16

**Note** Pin 6 +3.3V has a resettable fuse and can supply up to 0.5A to power I/O buffers in the COP controller.



## Power Requirements

In its standard configuration, the MVME3100 requires +5V for operation. On-board converters supply the processor core voltage, +3.3V, +1.8V, and +2.5V. For any installed PMC card that requires +12V or -12V, these voltages must be supplied by the chassis.

## Supply Current Requirements

Table A-1 provides an estimate of the typical and maximum current required from each of the input supply voltages.

**Table A-1. Power Requirements**

Model	Power
MVME3100 No PMCs or peripherals attached	Typical: 4.5A (22.5W) @ +5V.0 Maximum: 5.6A (28W) @ +5.0V

**Note** In a 3-row chassis, PMC current should be limited to 32 watts (total of both PMC slots). In a 5-row chassis, the PMC sites can support a total of 50 watts.

## Environmental Specifications

Table A-2 lists the environmental specifications, along with the board dimensions.

**Table A-2. MVME3100 Specifications**

Characteristics	Specifications
Operating Temperature	0° to +55° C or (inlet air temperature with forced air cooling)
Storage Temperature	-40° to +85° C
Relative Humidity	Operating: 5% to 90% non-condensing Non-operating: 5% to 90% non-condensing

**Table A-2. MVME3100 Specifications (continued)**

Characteristics	Specifications
Vibration	Operating: 6 Gs RMS, 5-200 Hz sine Non-operating: 6 Gs RMS, 20-2000 Hz random
Physical Dimensions	6U, 4HP wide (233.4 mm x 160 mm x 19.8 mm) (9.2 in. x 6.3 in. x 0.8 in)
Weight	468 g/16.5 oz. (IEEE handles)
MTBF	122,480 hours (calculated based on MIL-HDBK-217F Notice 1)



### Motorola Computer Group Documents

The Motorola publications listed below are referenced in this manual. You can obtain electronic copies of Motorola Computer Group publications by:

- Contacting your local Motorola sales office
- Visiting Motorola Computer Group's World Wide Web literature site, <http://www.motorola.com/computer/literature>

**Table B-1. Motorola Computer Group Documents**

Document Title	Motorola Publication Number
<i>MVME3100 Single-Board Computer Programmer's Reference Guide</i>	V3100A/PG
<i>MOTLoad Firmware Package User's Manual</i>	MOTLODA/UM
<i>PMCSpan PMC Adapter Carrier Board Installation and Use</i>	PMCSpanA/IH

To obtain the most up-to-date product information in PDF or HTML format, visit <http://www.motorola.com/computer/literature>.

## Manufacturers' Documents

For additional information, refer to the following table for manufacturers' data sheets or user's manuals. As an additional help, a source for the listed document is provided. Please note that, while these sources have been verified, the information is subject to change without notice.

**Table B-2. Manufacturers' Documents**

Document Title and Source	Publication Number
MPC8540 Integrated Processor Hardware Specifications Freescale Semiconductor Technical Call Center Telephone: +1 800 521 6274 Web Site: <a href="http://www.freescale.com">www.freescale.com</a>	MPC8540EC
MPC8540 PowerQUICC III™ Integrated Host Processor Reference Manual Freescale Semiconductor Technical Call Center Telephone: +1 800 521 6274 Web Site: <a href="http://www.freescale.com">www.freescale.com</a>	MPC8540RM
Tsi148 PCI/X to VME Bus Bridge User Manual Tundra Semiconductor Corporation 603 March Road Ottawa, Ontario, Canada K2K 2M5 Web Site: <a href="http://www.tundra.com">www.tundra.com</a>	80A3020_MA001_02
BCM5421S 10/100/1000BASE-T Gigabit Transceiver Broadcom Corporation Web Site: <a href="http://www.broadcom.com">www.broadcom.com</a>	BCM5421
BCM5221S 10/100BASE-Tx Single-Channel Signi-PHY Transceiver Broadcom Corporation Web Site: <a href="http://www.broadcom.com">www.broadcom.com</a>	BCM5221
Intel 31244 PCI-X to Serial ATA Controller Datasheet and Specification Update Intel Corporation Web Site: <a href="http://www.intel.com/design/storage/serialata/docs/gd31244.htm">www.intel.com/design/storage/serialata/docs/gd31244.htm</a>	27359505.pdf 27379405.pdf
S29GLxxxN MirrorBit™ Flash Family S29GL512N, S29GL256N, S29GL128N AMD, Inc. Web Site: <a href="http://www.amd.com/us-en/FlashMemory">www.amd.com/us-en/FlashMemory</a>	27631 Revision A Amendment 3 May 13, 2004
μPD720101 USB 2.0 Host Controller Datasheet NEC Electronics Web Site: <a href="http://www.necel.com/usb/en/document/index.html">www.necel.com/usb/en/document/index.html</a>	S16265EJ3V0DS00 April 2003
PCI6520CB Data Book PLX Technology, Inc. 870 Maude Avenue Sunnyvale, CA 94085 Web Site: <a href="http://www.plxtech.com">www.plxtech.com</a>	

**Table B-2. Manufacturers' Documents (continued)**

Document Title and Source	Publication Number
EXAR ST16C554/554D, ST68C554 Quad UART with 16-Byte FIFOs EXAR Corporation 48720 Kato Road Fremont, CA 94538 Web Site: <a href="http://www.exar.com">www.exar.com</a>	ST16C554/554D Rev. 3.1.0
2-Wire Serial EEPROM Atmel Corporation San Jose, CA Web Site: <a href="http://www.atmel.com/atmel/support">www.atmel.com/atmel/support</a>	AT24C512
Maxim DS1621 Digital Thermometer and Thermostat Maxim Integrated Products Web Site: <a href="http://www.maxim-ic.com">www.maxim-ic.com</a>	DS1621
Maxim DS1375 Serial Real-Time Clock Maxim Integrated Products Web Site: <a href="http://www.maxim-ic.com">www.maxim-ic.com</a>	Rev: 121203
TSOP Type I Shielded Metal Cover SMT Yamaichi Electronics USA Web Site: <a href="http://www.yeu.com">www.yeu.com</a>	



## Related Specifications

For additional information, refer to the following table for related specifications. For your convenience, a source for the listed document is also provided. It is important to note that in many cases, the information is preliminary and the revision levels of the documents are subject to change without notice.

**Table B-3. Related Specifications**

Document Title and Source	Publication Number
<b>VITA <a href="http://www.vita.com">http://www.vita.com</a></b>	
VME64 Specification	ANSI/VITA 1-1994
VME64 Extensions	ANSI/VITA 1.1-1997
2eSST Source Synchronous Transfer	VITA 2.0-2003
<b>PCI Special Interest Group (PCI SIG) <a href="http://www.pcisig.com">www.pcisig.com</a></b>	
Peripheral Component Interconnect (PCI) Local Bus Specification, Revision 2.0, 2.1, 2.2	PCI Local Bus Specification
PCI-X Addendum to the PCI Local Bus Specification	Rev 1.0b
<b>IEEE <a href="http://standards.ieee.org/catalog">http://standards.ieee.org/catalog</a></b>	
IEEE - Common Mezzanine Card Specification (CMC) Institute of Electrical and Electronics Engineers, Inc.	P1386 Draft 2.0
IEEE - PCI Mezzanine Card Specification (PMC) Institute of Electrical and Electronics Engineers, Inc.	P1386.1 Draft 2.0
<b>USB <a href="http://www.usb.org/developers/docs">http://www.usb.org/developers/docs</a></b>	
Universal Serial Bus Specification	Revision 2.0 April 27, 2000