

Cat. No. 43-1118  
**OWNER'S MANUAL**

Please read before using this equipment.

---

**ET-1118**

---

**900 MHz Digital Spread Spectrum Cordless  
Telephone with Caller ID and Call Waiting ID**



**RadioShack®**

## FEATURES

---

Your RadioShack ET-1118 900 MHz Digital Spread Spectrum Cordless Telephone uses the most advanced cordless telephone technology to give you superior audio quality and extended range.

The ET-1118's Caller ID unit records each caller's telephone number (and name, if available in your area) and the date and time of the call, as provided by your local phone company to Caller ID service subscribers. And, if you subscribe to Call Waiting with Caller ID, the ET-1118 shows you the incoming caller information, even when you are already on the phone.

Your ET-1118 has these features:

**900 MHz Operation** — provides longer range and less interference than many other cordless phones.

**Spread Spectrum Technology** — spreads the signal across several frequencies, providing additional security for your phone conversations.

**Caller ID Memory** — stores up to 50 Caller ID records.

**Headset Jack** — lets you connect an optional headset (available from your local RadioShack store) for hands-free convenience.

**Speakerphone** — lets you make or answer calls without using the handset.

**Dual Keypads** — a full set of keys on both the handset and base let you use either keypad to operate the phone.

**3-Line Liquid Crystal Display** — lets you view an entire Caller ID record on one screen.

**Two-Way Intercom/Paging System** — lets you send a signal from the base to the handset, or from the handset to the base, to page someone or locate the handset when it is away from the base. If someone answers, you can use the ET-1118 as an intercom.

**20-Number Memory Dialing** — lets you store up to 20 numbers (10 each in the handset and base) in memory for easy dialing.

**Volume Control** — lets you adjust the volume you hear through the handset.

**Adjustable Ringers** — you can set different volumes for the handset and base ringers.

**Ample Talk and Standby Time** — the supplied battery (when fully charged) provides about 4 hours of talk time or 7 days of standby time.

**20 Channels** — automatically selects a clear channel when you make or answer a call.

© 1999 Tandy Corporation.  
All Rights Reserved.

RadioShack is a registered trademark used by Tandy Corporation.

---

**Security Access-Protection Code** — automatically prevents other cordless phone users from using your phone line while the handset is off the base.

**Redial** — lets you quickly redial the last number dialed.

**Flash** — sends an electronic switch-hook signal for use with special phone services, such as Call Waiting.

**Tone/Pulse Dialing** — lets you use either type of service, and you can easily switch from pulse to tone dialing for long-distance, bank-by-phone, or other special services.

**Auto Talk** — lets you set the handset so you can answer a call by simply lifting the handset from the base or by pressing any key when the handset is away from the base.

**Hearing-Aid Compatibility** — lets you use your phone with hearing aids that have a T (telephone) switch.

This telephone is UL listed and has been tested and found to comply with all applicable FCC standards.

We recommend you record your phone's serial number here. The number is on the bottom of the base.

Serial Number \_\_\_\_\_



## IMPORTANT CALLER ID INFORMATION

To use the phone's Caller ID and Caller ID with Call Waiting features, you must be in an area where those services are available and you must subscribe to those services through your local phone company.

Where Caller ID is offered, one or more options are generally available:

- caller's number only
- caller's name only
- caller's name and number

**WARNING:** To reduce the risk of fire or shock hazard, do not expose this product to rain or moisture.

	<b>CAUTION</b> RISK OF ELECTRIC SHOCK. DO NOT OPEN.	
<b>CAUTION:</b> TO REDUCE THE RISK OF ELECTRIC SHOCK, DO NOT REMOVE COVER OR BACK. NO USER-SERVICEABLE PARTS INSIDE. REFER SERVICING TO QUALIFIED PERSONNEL.		



This symbol is intended to alert you to the presence of uninsulated dangerous voltage within the product's enclosure that might be of sufficient magnitude to constitute a risk of electric shock. Do not open the product's case.



This symbol is intended to inform you that important operating and maintenance instructions are included in the literature accompanying this product.

---

---

**Important:**

- Cordless phones such as this one require AC power to operate. When the AC power is off, you cannot dial out or receive incoming calls using your ET-1118. To be safe, you should also have a phone that does not need AC power to operate (not a cordless phone) so you can still make and receive calls if there is an AC power failure.
- When AC power is lost, the ET-1118 loses the security access-protection code connection between the base and the handset. When power is restored, put the handset on the base briefly to restore this connection so you can use the handset.

**READ THIS BEFORE  
INSTALLATION**

Each device that you connect to the phone line draws power from the phone line. We refer to this power draw as the device's ringer equivalence number, or REN. The REN is on the bottom of the base.

If you are using more than one phone or other device on the line, add up all the RENs. If the total is more than five, your phones might not ring. In rural areas, a total REN of three might impair ringer operation. If ringer operation is impaired, remove a device from the line.

**FCC STATEMENT**

This telephone complies with Part 68 of *FCC Rules*. You must, upon request, provide the FCC registration number and the REN to your phone company. These numbers are on the bottom of the base.

**Note:** You must not connect your phone to any of the following:

- coin-operated systems
- party-line systems
- most electronic key phone systems

This phone complies with the limits for a Class B digital device as specified in Part 15 of *FCC Rules*. These limits provide reasonable protection against radio and TV interference in a residential area. However, your equipment might cause TV or radio interference even when it is operating properly. To eliminate interference, you can try one or more of the following corrective measures.

- Reorient or relocate the receiving antenna.
- Increase the distance between the equipment and the radio or TV.
- Use outlets on different electrical circuits for the equipment and the radio or TV.

Consult your local RadioShack store if the problem still exists.

# CONTENTS

---

<b>Installation</b> .....	<b>7</b>
Mounting the Phone .....	7
On a Desk Top .....	7
On a Wall Plate or Wall .....	8
Connecting and Charging the Battery Pack .....	10
Setting the Dialing Mode .....	11
Setting the Ringers' Volume .....	11
Using Auto Talk .....	12
Turning Caller ID/Call Waiting On/Off .....	12
Storing Your Area Code .....	13
<b>Telephone Operation</b> .....	<b>14</b>
Making and Receiving Calls with the Handset .....	14
Adjusting the Handset Volume .....	14
Making and Receiving Calls with the Speakerphone .....	14
Switching Between the Handset and Speaker .....	14
Using Both the Handset and Speakerphone .....	15
Using Hold .....	15
Using Mute .....	15
Using Redial .....	15
Using Flash .....	16
Using Tone Services on a Pulse Line .....	16
Using Page/Intercom .....	16
Transferring a Call between the Handset and Base .....	17
Memory Dialing .....	17
Storing a Number in the Handset's Memory .....	18
Editing or Deleting a Number in the Handset's Memory .....	19
Storing a Number in the Base's Memory .....	19
Entering a Pause .....	20
Reviewing Memory Numbers (Handset Only) .....	20
Dialing a Memory Number .....	20
Chain-Dialing Service Numbers .....	20
Testing Stored Emergency Numbers .....	21
Using a Headset .....	21
<b>Caller ID Operation</b> .....	<b>22</b>
Reviewing Caller ID Records .....	22
Caller ID Messages .....	23
Dialing Numbers from a Caller ID Record .....	23
Storing a Caller ID Record to the Handset's Memory .....	23
Deleting Caller ID Records .....	24

---

<b>Troubleshooting</b> .....	<b>25</b>
<b>Care and Maintenance</b> .....	<b>27</b>
Replacing the Battery Pack .....	28
The FCC Wants You to Know .....	29
Lightning .....	29

# INSTALLATION

---

## MOUNTING THE PHONE

You can place the ET-1118's base on a desk or table, mount it on a standard wall plate, or mount it directly on a wall. Choose a location that is:

- near an AC outlet
- near a modular telephone line jack
- out of the way of normal activities
- away from electrical machinery, electrical appliances, metal walls or filing cabinets, wireless intercoms, alarms, and room monitors
- away from other cordless phones

The base's location affects the phone's range. If you have a choice of several locations, try each to see which provides the best performance.

### Cautions:



You must use a Class 2 power source that supplies 9 volts AC and delivers at least 500 mA. Its center tip must be set to positive and its plug must fit the ET-1118's **DC IN 9V** jack. The supplied adapter meets these specifications. Using an adapter that does not meet these specifications could damage the ET-1118 or the adapter.

- Always connect the AC adapter to the ET-1118 before you connect it to AC power. When you finish, disconnect the adapter from AC power before you disconnect it from the ET-1118.

### Notes:

- Your telephone connects directly to a modular telephone line jack. If your phone line jack is not a modular jack, you can update the wiring yourself, using jacks and adapters available at your local RadioShack store. Or, you can let the phone company update the wiring for you.
- The USOC number of the jack to be installed is RJ11C (RJ11W for a wall plate).

## On a Desk Top

1. Plug one end of the supplied long modular cord into the **TEL LINE** jack on the back of the base.

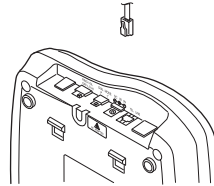

2. Plug the modular cord's other end into a modular telephone line jack.
3. Insert the supplied AC adapter's barrel plug into the **DC IN 9V** jack on the back of the base.

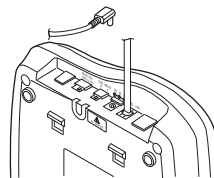

- 
4. Route the adapter's cord through the strain relief slot on the bottom of the base.

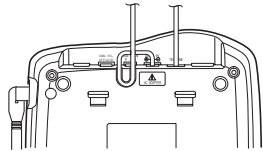

2. Plug one end of the supplied short modular cord into the **TEL LINE** jack on the back of the base.

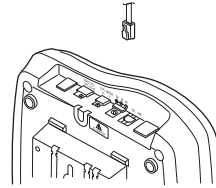

5. Plug the adapter into a standard AC outlet.
6. Lift the base's antenna to a vertical position.

3. Insert the supplied AC adapter's barrel plug into the **DC IN 9V** jack.

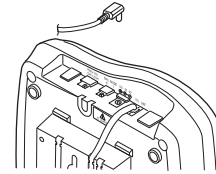

### On a Wall Plate or Wall

1. Insert the two tabs at the top of the narrow end of the supplied bracket into the base's upper tab slots as shown, then press down on the bracket's latches and insert them into the lower slots.

4. Route the adapter and modular cords through the grooves on the bracket.

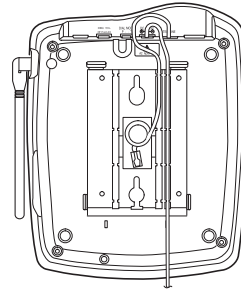
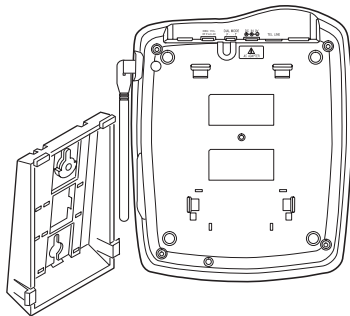



5. Plug the modular cord's other end into the wall plate jack, then align the bracket's keyhole slots with the wall plate studs and slide the base downward to secure it.

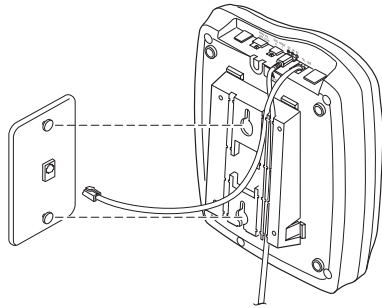

6. Plug the adapter into a standard AC outlet.
7. Press and lift out the handset holder, flip it over as shown, then snap it back into place so it holds the handset.

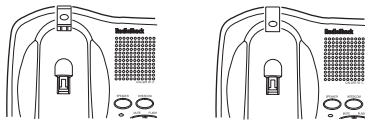

8. Lift the base's antenna to a vertical position.

**Note:** To mount the phone directly on a wall, you need two screws (not supplied) with heads that fit into the keyhole slots on the bottom of the base.

Follow Steps 1, 3, 4, and 6–8 under “On a Wall Plate or Wall,” then follow these

additional instructions for placement on a wall.

1. Drill two holes  $3\frac{15}{16}$  inches (100 mm) apart. Then thread a screw into each hole, letting the heads extend about  $\frac{3}{32}$  inch (3 mm) from the wall.

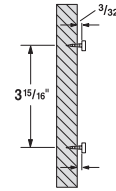

2. Plug one end of the supplied long modular cord into the **TEL LINE** jack at the back of the base.

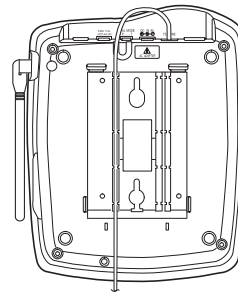

3. Align the bracket's keyhole slots with the mounting screws and slide the base downward to secure it.

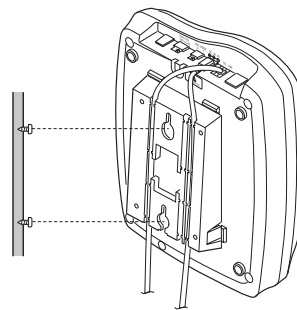

---

## CONNECTING AND CHARGING THE BATTERY PACK

The ET-1118 comes with a rechargeable nickel-cadmium battery pack in the handset but not connected. Before using your phone, you must connect the battery pack and then charge it for about 24 hours.

1. Press down and slide off the battery pack compartment cover as shown.

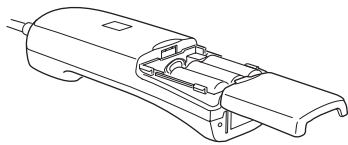

2. Lift the battery pack out of the compartment.
3. Plug the battery pack's connector into the socket in the compartment (the connector fits only one way), then replace the battery pack.

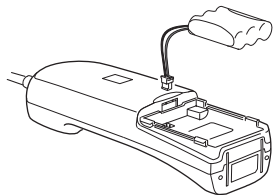

4. Replace the cover.

To charge the battery pack, place the handset on the base either faceup or facedown. The CHARGE indicator on the base lights and **Total:00** appears on the handset display.

Recharge the battery pack when **Low Battery** flashes on the display.

**Important:** Be sure the battery pack is properly connected before you try to charge it. The **CHARGE** indicator lights when the handset is on the base, even if the battery pack is not connected.

### Notes:

- When you first use the phone after charging or recharging the battery pack, the phone might not work and you might hear an error tone when you press **TALK**. If this happens, return the handset to the base for about 5 seconds. This resets the security access-protection code.
- If the base loses power for 60 minutes while the handset is away from it or the handset's battery pack is completely discharged, the security access-protection code might be lost. To reset the code, return the handset to the base for about 5 seconds.
- Using a pencil eraser, clean the charging contacts on the handset and the base about once a month.

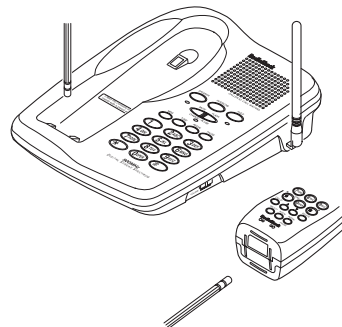

- If the battery pack becomes weak during a call, the handset beeps every 3 seconds and **Low Battery** flashes. If this happens, you cannot make another call on the phone until you recharge the battery pack.
- About once a month, fully discharge the battery pack by keeping the handset off the base until **Low Battery** flashes. Otherwise, the battery pack loses its ability to fully recharge.
- If the display is blank and the phone does not work, recharge the battery pack. (The battery power might be too low to light the display.)
- If you are not going to use your phone for an extended period of time, disconnect the battery pack. This increases the battery pack's usable life.
- The supplied battery pack should last for about a year. When it loses its ability to fully recharge, order a replacement battery pack from your local RadioShack store (see "Replacing the Battery Pack" on Page 28).

## SETTING THE DIALING MODE

Set **DIAL MODE** on the back of the base for the type of service you have. If you are not sure which type you have, once

the battery pack is fully charged, do this test.

1. Be sure **DIAL MODE** is set to **T** (tone).

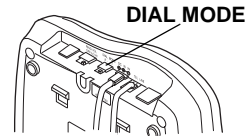

2. Lift the handset, press **TALK**, and listen for a dial tone.

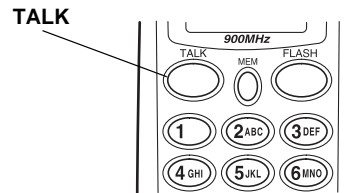

3. Press any number except **0**.

**Note:** If your phone system requires that you dial an access code (**9**, for example) before you dial an outside number, do not press the access code number either.

If the dial tone stops, you have touch-tone service. Leave **DIAL MODE** set to **T**.

If the dial tone continues, you have pulse service. Set **DIAL MODE** to **P** (pulse).

## Setting the Ringers' Volume

The ET-1118 lets you set different volumes for the handset and base ringers.

At any time except during a call, press ▼ or ▲ to set the handset's ringer volume. The phone rings at the selected volume and the display shows **Ringer Low** or **Ringer High**.

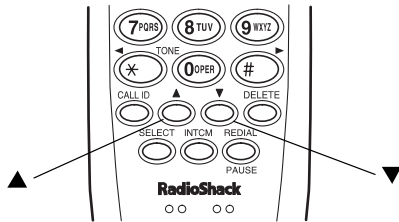

To set the base's ringer volume, set **RING VOL** on the back of the base to **OFF**, **LO**, or **HI**. When you set **RING VOL** to **OFF**, the base (and the handset if it is on the base) does not ring but the other phone connected to the same line rings. If the handset is away from the base, the handset also rings.

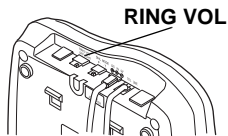

**Note:** When you set the auto talk function to off, the handset rings when you lift the handset from the base. See "Using Auto Talk."

## USING AUTO TALK

Your phone is preset so you must press **TALK** when you lift the handset from the base to answer a call. With auto talk turned on, you can answer a call by just lifting the handset from the base or by

pressing any key when the handset is away from the base.

Follow these steps to turn auto talk on or off.

1. Lift the handset then hold down **CALL ID**. A menu appears with **Auto Talk** selected.

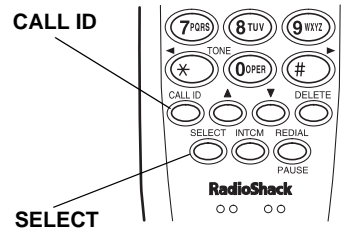

2. Press **SELECT** to change the auto talk setting. **On** or **Off** appears indicating the selected setting.
3. To clear the display, press **CALL ID** or return the handset to the base.

## TURNING CALLER ID/ CALL WAITING ON/OFF

If you have Call Waiting with Caller ID service, you can set the ET-1118 to show Caller ID information for an incoming call even while you are already on the phone.

Follow these steps to turn the Caller ID/ Call Waiting feature on or off.

1. Lift the handset then hold down **CALL ID**.
2. Press **2** or ▼ to select **CIDCW** (Caller ID/Call Waiting).

3. Press **SELECT** to change the Caller ID/Call Waiting setting. **On** or **Off** appears indicating the selected setting.
4. Press **CALL ID** or return the handset to the base to store the new setting.

## STORING YOUR AREA CODE

To quickly dial a number from a Caller ID record (see "Dialing Numbers from a Caller ID Record" on Page 23) or to correctly store a number from a record into a memory dialing location (see "Storing a Caller ID Record to the Handset's Memory" on Page 23), you must store your local area code in the ET-1118's memory. Then, when you dial from a Caller ID record, the ET-1118 skips the area code if it matches the one you stored.

Follow these steps to store your area code.

1. Lift the handset then hold down **CALL ID**.
2. Press **3** (or **▼** twice) to select **Area Code**.
3. Press **SELECT**, then enter your 3-digit area code. If you make a mistake, repeatedly press **▶** or **◀** to move the cursor over the incorrect digit, then enter the correct number.

**Note:** If an area code is already stored, it appears on the display. To delete the area code, press **DELETE**

three times. Then enter your area code.

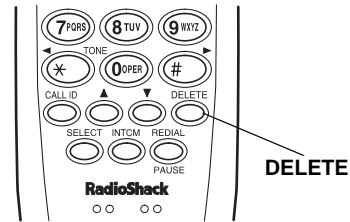

4. Press **SELECT** to store the area code.
5. To clear the display when you finish, press **CALL ID** or return the handset to the base.

## TELEPHONE OPERATION

---

### MAKING AND RECEIVING CALLS WITH THE HANDSET

To make a call, lift the handset, then press **TALK**. The IN USE indicator on the base lights. Dial the number. You see the number as you dial, then (about 5 seconds later) the call's elapsed time.

**Note:** You can also dial the number before you press **TALK**. If you make a mistake, repeatedly press **DELETE** until the incorrect digit is deleted, then enter the correct number. To delete the entire number, hold down **DELETE** for over one second.

To answer a call, lift the handset from the base and press **TALK**. If auto talk is on, just lift the handset from the base, or, if the handset is away from the base, press any key to answer a call.

To end a call, place the handset on the base or press **TALK**.

### ADJUSTING THE HANDSET VOLUME

To adjust the volume of the sound you hear through the handset, during a call, press **▼** or **▲**. The display shows **Volume Low**, **Volume Medium**, **Volume High**, or **Volume Maximum**. When you press **▲** when the volume is maximum or **▼** when the volume is low, the error tone sounds.

### MAKING AND RECEIVING CALLS WITH THE SPEAKERPHONE

To make or answer a call using the speakerphone, press **SPEAKER**. The **SPEAKER** indicator lights. When you hear a dial tone, dial the number.

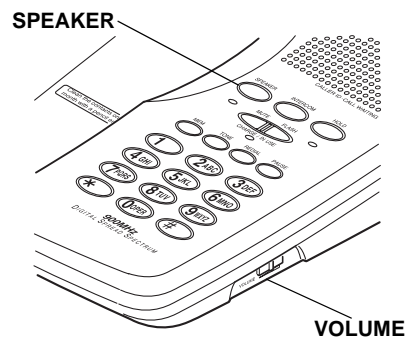

To set the speakerphone's volume, slide **VOLUME** on the right side of the base.

To end a speakerphone call, press **SPEAKER** again.

### SWITCHING BETWEEN THE HANDSET AND SPEAKER

To switch to the speakerphone while you are using the handset, press **SPEAKER** on the base. When you hear the conversation or dial tone on the speakerphone, press **TALK** on the handset.

---

To switch to the handset while you are using the speakerphone, simply lift the handset off the base. If the handset is away from the base, press **TALK**, then press **SPEAKER**.

## USING BOTH THE HANDSET AND SPEAKERPHONE

If someone else is using the speakerphone, press **TALK** on the handset to join the conversation.

If someone else is using the handset, press **SPEAKER** on the base to join the conversation.

During the call, one person can hang up and let the call continue at the other keypad. Or, both people can hang up at the same time to end the call.

**Note:** If you hear a high-pitched noise from the base's speaker, the handset and the base are too close together.

## USING HOLD

Press **HOLD** to put a speakerphone call on hold. The HOLD indicator lights.

While a call is on hold, you can make an intercom call (see "Using Page/Intercom" on Page 16) between the handset and the base without disconnecting the call.

To release a call from hold, lift the handset and press **TALK**, press **SPEAKER** or **HOLD** on the base, or pick up any extension phone on the same line.

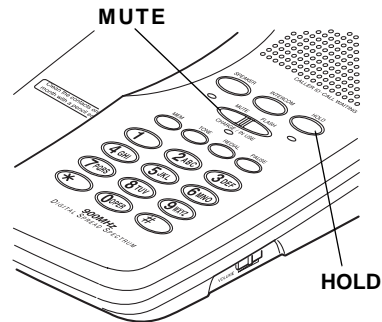

## USING MUTE

While talking on the speakerphone, you can temporarily turn off the ET-1118's microphone by pressing **MUTE** so the other party cannot hear you. The **SPEAKER** indicator flashes.

Press **MUTE** or **SPEAKER** to resume your conversation.

## USING REDIAL

You can quickly dial the last number dialed. Press **SPEAKER** or lift the handset and press **TALK**, then press **REDIAL**.

### Notes:

- You can also press **REDIAL** on the handset first, then press **TALK**.

- The redial memory for each keypad is separate. You cannot redial a number you dialed on the handset's keypad using **REDIAL** on the base's keypad, and vice versa.
- The redial memory holds up to 32 digits, so you can redial long-distance as well as local numbers.
- The redial memory also holds pause entries. See "Entering a Pause" on Page 20.

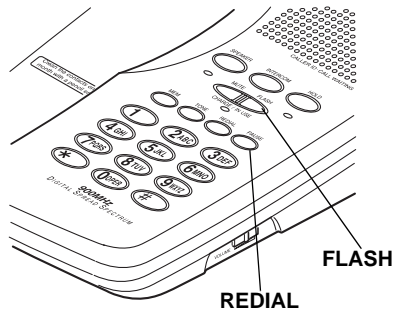

## USING FLASH

**FLASH** performs the electronic equivalent of a switchhook operation for special services, such as Call Waiting.

For example, if you have Call Waiting, press **FLASH** to answer an incoming call without disconnecting the current call. Press **FLASH** again to return to the first call.

**Note:** If you do not have any special phone services, pressing **FLASH** might disconnect the current call.

## USING TONE SERVICES ON A PULSE LINE

Some special services, such as bank-by-phone, require tone signals. If you have pulse service, you can still use these special tone services by following these steps.

1. Be sure **DIAL MODE** is set to **P**.
2. Dial the service's main number.
3. When the service answers, press **TONE (\*)** on the handset (**TONE** on the base). Any additional numbers you dial are sent as tone signals.
4. When you hang up, the phone automatically resets to pulse dialing.

## USING PAGE/INTERCOM

You can use the ET-1118 as a two-way pager and intercom between the base and the handset. This is useful if the handset is away from the base and you want to locate it, or if you want to have a conversation between someone with the handset and someone at the base.

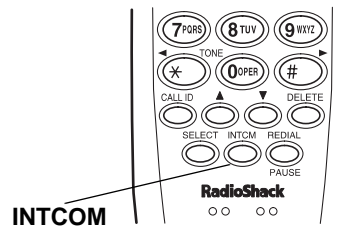



---

To page the base from the handset, press **INTCM**. **Paging Base** appears, and the base and handset ring. Press **SPEAKER** or **INTERCOM** on the base to answer the page. **Intercom** appears on the handset's display.

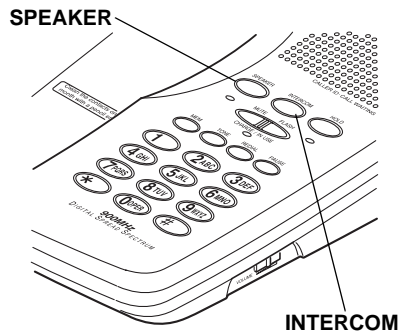

To page the handset from the base, press **INTERCOM**. The handset and base ring, and **Paging** appears on the handset's display. Press **TALK** or **INTCM** on the handset to answer the page. **Intercom** appears.

To end an intercom call, press **TALK** on the handset, press **SPEAKER** on the base, or hang up the handset.

If a call comes in during an intercom conversation, either the person at the base or the person at the handset can answer the call. Press **TALK** on the handset or **SPEAKER** on the base once to end the intercom call, then press **TALK** or **SPEAKER** again to answer the incoming call.

**Note:** The intercom does not operate if the party being paged is already on a call.

## Transferring a Call between the Handset and Base

You can use the ET-1118's intercom feature to transfer a call between the handset and the base.

To transfer a call from the handset to the base, press **INTCM**. The call is put on hold, and **Paging Base** and **Hold** appear. When the person at the base answers, press **TALK**. The call is released from hold and transferred to the base. To return to handset use, press **TALK** again.

To transfer a call from the base to the handset, press **INTERCOM**. The call is put on hold, and **Paging** and **Hold** appear on the handset's display. When the person with the handset answers, press **SPEAKER**. The call is released from hold and transferred to the handset. To return to base use, press **SPEAKER** again.

## MEMORY DIALING

You can store up to 20 numbers in memory (10 each in the handset's and base's memory), then dial a stored number by pressing a memory location number. You can also store a name with each number in the handset's memory.

Use the supplied memory directory stickers to record your stored numbers. Peel the backing from each sticker and attach them to the phone as shown.

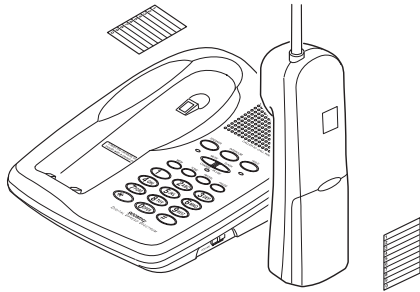

## Storing a Number in the Handset's Memory

Each number stored in the handset's memory can be up to 20 digits, and each name can be up to 14 characters.

**Note:** An error tone sounds and the phone exits the storing process if you wait more than 20 seconds between each keypress.

1. Lift the handset.
2. Hold down **MEM** until **Memory Store** and a list of memory location numbers (and names, if any) appear.

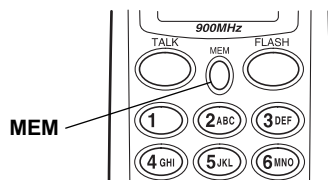

3. Choose a memory location (1–0) by pressing a number or by repeatedly pressing ▼ or ▲.
4. To store a name, press **SELECT**. **Store Name** appears.

If you do not want to enter a name, skip to Step 6. **<Memory n>** appears as the name (**n** is the memory location number you selected).

To enter a name, use ▼ or ▲ to select the characters and ► or ◀ to move the cursor.

Repeatedly press ▼ to see the characters in alphabetical order. (The display shows uppercase letters first, then lowercase letters, numbers, and special characters.)

### Notes:

- Press ▲ to see the characters in reverse order.
- You can hold down ▼ or ▲ to scroll rapidly through the characters.

If you make a mistake, move the cursor over the error, then enter the correct character, or press **DELETE** to delete a character. To delete all the characters, hold down **DELETE** for at least 1 second.

5. Press **SELECT**. **Store Number** appears.
6. Enter the phone number and any tone or pause entries (see “Using Tone Services on a Pulse Line” on Page 16 and “Entering a Pause” on Page 20).

- 
7. Press **SELECT**. The phone beeps and **Memory n Stored** appears. After 2 seconds, **Memory Store** appears, and you can repeat Steps 3–6 to store more numbers.

To replace a stored number, simply store a new one in its place.

### Editing or Deleting a Number in the Handset's Memory

1. Lift the handset.
2. Hold down **MEM** until **Memory Store** and a list of memory location numbers appear on the display.
3. Choose a memory location (0–9) by pressing a number or by repeatedly pressing **▼** or **▲**.
4. Press **SELECT**. The options listed below appear. Press **▼** or **▲** to choose an option, follow the instructions listed, then press **SELECT**.

**Edit Memory n** — Edit the record as described in Steps 5 through 7 of “Storing a Number in the Handset's Memory” on Page 16.

**Delete Memory n** — The display prompts you to confirm the deletion. Move the cursor to **Yes**, then press **SELECT** or **DELETE**. The phone beeps, and **Memory n Deleted** appears.

**Go Back** — Returns you to the list of memory numbers.

5. When you finish editing or deleting memory numbers, press **MEM** or

return the handset to the base to exit the **Memory Store** display.

### Storing a Number in the Base's Memory

**Note:** An error tone sounds and the phone exits the storing process if you wait more than 20 seconds between each keypress.

1. Press **MEM**. The IN USE indicator blinks.
2. Enter the number (up to 16 digits) and any tone or pause entries (see “Using Tone Services on a Pulse Line” on Page 16 and “Entering a Pause” on Page 20).

#### Notes:

- An error tone sounds and the phone exits the storing process if you enter more than 16 digits.
  - Each tone or pause entry uses one digit of memory.
3. Press **MEM** again, then enter the memory location number (0–9) where you want to store the phone number. A tone sounds indicating that the number is stored.

To replace a number in the base's memory, simply store a new number in its place. To erase a memory number, press **MEM** twice, then press the memory location number (0–9) you want to erase. A tone sounds indicating that the memory location has been erased.

---

## Entering a Pause

In some telephone systems, you must dial an access code (9, for example) and wait for a second dial tone before you can dial an outside number. You can store the access code with the phone number. However, you should also store a pause after the access code to allow the outside line time to connect.

To enter a 2-second pause, press **PAUSE** (**REDIAL/PAUSE** on the handset). **P** appears on the display if you are storing a number into the handset's memory. You can add more pause entries for a longer pause.

## Reviewing Memory Numbers (Handset Only)

To review your memory numbers, press **MEM**. The list of the first three memory locations appears with the name stored with each number (or **<Memory n>** if you did not store a name). Press **▼** or **▲** to scroll through the list if necessary.

To see the stored phone numbers, press **►**. An arrow to the right of the number indicates it is longer than 14 digits. Press **►** again to see the rest of the number. Repeatedly press **◀** to return to the name display.

To exit the memory number list, press **MEM**.

To see a stored name and phone number at the same time, press **SELECT** when the cursor is next to the desired

memory location number. To exit this display, hold down **DELETE** until the display clears.

## Dialing a Memory Number

To dial a number stored in the handset's memory, lift the handset and press **MEM**. The list of memory location numbers appears. Choose a memory location (0–9) by pressing a number or by repeatedly pressing **▼** or **▲**, then press **TALK**.

To dial a number stored in the base's memory, press **SPEAKER**. When you hear a dial tone, press **MEM**, then press the memory location number for the number you want to dial.

**Note:** If you select an empty memory location, the base beeps 5 times.

## Chain-Dialing Service Numbers

For quick recall of numbers for special services (such as bank by phone), store each group of numbers in its own memory location.

Dial the service's main number first. Then, at the appropriate place in the call, press **MEM** and the number for the location where the additional information is stored.

---

---

## Testing Stored Emergency Numbers

If you store an emergency service's number (police department, fire department, ambulance) and you choose to test the stored number, make the test call during the late evening or early morning hours to avoid peak demand periods. Also, remain on the line to explain the reason for your call.

speakerphone or the keys on the handset.

You can use a handset holder (available from your local RadioShack store) to hang the handset on your belt for greater convenience.

When you finish using the headset, disconnect it from the handset and close the rubber cover to protect the jack.

## USING A HEADSET

You can talk with hands-free convenience using an optional headset that has a  $\frac{3}{32}$ -inch (2.5-mm) plug. Contact your local RadioShack store for a suitable headset.

To connect the headset, open the rubber cover marked  $\Omega$  on the side of the handset, then insert the headset's plug into the jack.

### Notes:

- Connecting a headset disconnects the handset's earpiece and microphone.
- **VOL** ▼ or ▲ on the handset also controls the connected headset's volume.
- If you place the handset on the base to recharge it while the headset is connected, be sure the handset seats properly.

With a headset connected, you can make or answer calls as usual using the

## CALLER ID OPERATION

If you subscribe to Caller ID service from your phone company, the phone company sends information about the call, as well as the time and date, between the first and second rings of every call you receive.

The ET-1118 displays this information when it receives a call, and it stores up to 50 Caller ID records for later review. It also shows if caller information is unavailable or if the name and number were blocked by the caller (see "Caller ID Messages" on Page 23).

If you subscribe to Call Waiting with Caller ID, you will hear a tone through the handset when a call comes in, then the Caller ID record appears. If you want to answer the incoming call, press **FLASH**. To resume the previous phone conversation, press **FLASH** again.

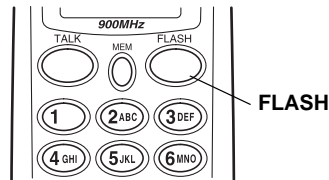

If the phone's Caller ID memory becomes full, any new call replaces the oldest call's record.

## REVIEWING CALLER ID RECORDS

To review the Caller ID records, lift the handset and press **CALL ID**. The number of new Caller ID records, if any, and the total number of records appears.

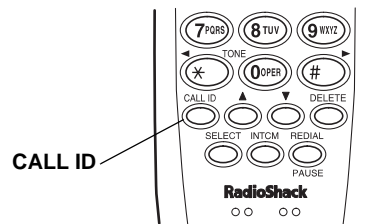

**Note:** If the handset is faceup on the base, it always shows the number of Caller ID records, so you can see if you have new records to review.

Repeatedly press ▼ to scroll through the Caller ID records from the newest to the oldest, or ▲ to scroll back through the records. To scroll quickly through the records, hold down ▼ or ▲.

When you scroll past the oldest record, **End** appears. When you scroll past the newest record, the record totals appear.

The top line of each record shows the date, time and the number of calls from that number. The second line shows the caller's name, and the third line shows the caller's phone number.

## Caller ID Messages

Display	Description
<b>New:XX</b> <b>Total:XX</b>	Shows the number of new Caller ID records (records you have not reviewed) and the total number of records.
<b>Private Name</b> <b>Private Number</b>	The caller has blocked the Caller ID information from being sent.
<b>Unknown Name</b> <b>Unknown Number</b>	The caller is not within a Caller ID service area.
<b>Incomplete Data</b>	Appears if there was an error during the transmission of Caller ID information. Minor electrical disturbances can affect Caller ID information. Occasional errors are normal. If the phone frequently displays Incomplete Data, contact your local telephone company or RadioShack store for assistance.
<b>End</b>	Appears when you scroll past the last Caller ID record.

## DIALING NUMBERS FROM A CALLER ID RECORD

To dial a local number stored in a Caller ID record, recall the record, then press **TALK**. If it is a long distance call, press **1** (**1** appears before the displayed number) before pressing **TALK**.

**Note:** If a Caller ID record does not contain a phone number (if it was blocked by the caller) you cannot dial from that record.

## STORING A CALLER ID RECORD TO THE HANDSET'S MEMORY

Follow these steps to store the name and number from a Caller ID record into a handset memory location.

**Note:** To store a record from a Caller ID record into the base memory, recall the record, follow steps in "Storing a Number in the Base's Memory" on Page 19.

1. Recall the record you want to store, then press **MEM**. **Select Location** appears.
2. Choose a memory location by pressing its number (**0-9**) or scrolling the list using **▼** or **▲**, then press **SELECT**.

If the selected location is empty, the phone beeps to confirm that it stored the number, then the Caller ID record appears.

---

If a record exists in the selected location, **Replace Memory?** appears, prompting you to confirm the replacement. Move the cursor to **Yes** or **No**, then press **SELECT**.

## **DELETING CALLER ID RECORDS**

You can delete Caller ID records individually or all at once.

To delete a single record, recall it, then press **DELETE**. **Delete Message?** appears, prompting you to confirm the deletion. Move the cursor to **Yes** or **No**, then press **SELECT** or **DELETE**.

To delete all the records at once, press **DELETE** while the total number of records is on the display. **Delete All?** appears, prompting you to confirm the deletion. Move the cursor to **Yes** or **No**, then press **SELECT** or **DELETE**.



## TROUBLESHOOTING

---

We do not expect you to have any problems with your phone, but if you do, the following suggestions might help.

Problem	Suggestion
The phone does not work or works poorly.	Be sure the base's phone line cord and AC adapter are correctly and securely connected.
	Be sure the battery pack in the handset is connected and charged.
	Return the handset to the base for a few seconds to reset the security access-protection code.
The display flashes slowly when the handset is faceup on the base.	Be sure the battery pack in the handset is properly connected.
The handset stops working or works poorly during a call.	Move the handset closer to the base.
	Lift the base's antenna to a fully vertical position.
	Be sure the handset's battery pack is charged. (If the battery pack power is too low, it does not have enough power to light <b>Low Battery</b> on the display.)
Low volume or unusual sounds.	Someone has picked up another phone on the same line. Hang up the other phone.
Severe noise interference.	Keep the handset away from computers, remote control toys, wireless microphones, alarm systems, intercoms, room monitors, fluorescent lights, and electrical appliances.
	Move to another location or turn off the source of interference.
	Hang up and redial the number.
The phone cannot be operated at a useful distance from the base because the signal becomes weak or noisy (handset's range has decreased).	Lift the base's antenna to a fully vertical position.
	Be sure neither the handset's nor base's antenna is touching a metal surface.
	Recharge the battery pack.

Problem	Suggestion
The handset battery pack does not charge.	Check the charging contacts on the handset and base. If they are dirty, clean them with a pencil eraser.
	Be sure the battery pack is properly connected.
	Be sure the handset is properly seated on the base.
	Replace the battery pack (see "Replacing the Battery Pack" on Page 28).
The handset does not ring or receive a page.	Lift the base's antenna to a fully vertical position.
	Move the handset closer to the base.
	Move the base away from other electrical devices.
	Recharge the battery pack.
You have an incoming call, but do not receive any Caller ID information.	Let the phone ring twice before you answer so the system has time to record the Caller ID information.
	Check that the system is correctly and securely connected.
	Call your phone company to verify that your Caller ID service is active.

If you still have problems, disconnect the ET-1118. If other phones on the same line work properly, the fault is in this phone or its installation. If you cannot find the problem, take your ET-1118 to your local RadioShack store for assistance.

## CARE AND MAINTENANCE

---

Your RadioShack ET-1118 900 MHz Digital Spread Spectrum Cordless Telephone is an example of superior design and craftsmanship. The following suggestions will help you care for your ET-1118 so you can enjoy it for years.



Keep the ET-1118 dry. If it gets wet, wipe it dry immediately. Liquids might contain minerals that can corrode the electronic circuits.



Use and store the ET-1118 only in normal temperature environments. Temperature extremes can shorten the life of electronic devices, damage batteries, and distort or melt plastic parts.



Keep the ET-1118 away from dust and dirt, which can cause premature wear of parts.



Handle the ET-1118 gently and carefully. Dropping it can damage circuit boards and cases and can cause the ET-1118 to work improperly.



Use only fresh batteries of the required size and recommended type. Batteries can leak chemicals that damage your ET-1118's electronic parts.



Wipe the ET-1118 with a damp cloth occasionally to keep it looking new. Do not use harsh chemicals, cleaning solvents, or strong detergents to clean the ET-1118.

Modifying or tampering with the ET-1118's internal components can cause a malfunction and might invalidate its warranty and void your FCC authorization to operate it. If your ET-1118 is not performing as it should, take it to your local RadioShack store for assistance. If the trouble is affecting the telephone lines, the phone company can ask you to disconnect your ET-1118 until you have resolved the problem.

---

---

## REPLACING THE BATTERY PACK

If you follow the instructions in “Connecting and Charging the Battery Pack” on Page 10, the battery pack should last about one year. If the battery pack does not hold a charge for more than 2 hours after an overnight charge, replace it with a new 3.6-volt, 600 mAh battery pack with a connector that fits the socket in the battery compartment. You can order a replacement battery pack through your local RadioShack store.

Install the new battery pack as described below, then charge it for about 24 hours.

**Note:** To avoid losing redial memory and the security code, begin charging the new battery pack within 2 minutes.

1. Press down and slide off the battery pack compartment cover.
2. Lift the battery pack out of the compartment, then gently pull on the battery connector to disconnect it.
3. Insert the new battery pack’s connector into the socket in the compartment, place the battery pack into the compartment.
4. Replace the cover.

### Cautions:

- You must use a replacement battery pack of the same size and type.
- Do not dispose of the battery pack in a fire because it might explode.

- Do not open or mutilate the battery pack.
- Be careful not to short the battery pack by touching the connector’s pins with conducting materials, such as rings, bracelets, and keys. The battery pack or conductor might overheat and burn.

If you have trouble replacing the battery pack, take the phone to your local RadioShack store for assistance.

**Important:** This telephone can use nickel cadmium rechargeable batteries. At the end of a nickel cadmium battery’s useful life, it must be recycled or disposed of properly. Contact your local, county, or state hazardous waste management authorities for information on recycling or disposal programs in your area or call 1-800-843-7422. Some options that might be available are: municipal curbside collection, drop-off boxes at retailers such as your local RadioShack store, recycling collection centers, and mail-back programs.



---

---

## **THE FCC WANTS YOU TO KNOW**

In the unlikely event that your phone causes problems on the phone line, the phone company can temporarily discontinue your service. If this happens, the phone company attempts to notify you in advance. If advance notice is not practical, the phone company notifies you as soon as possible and advises you of your right to file a complaint with the FCC.

Also, the phone company can make changes to its lines, equipment, operations, or procedures that could affect the operation of this telephone. The telephone company notifies you of these changes in advance, so you can take the necessary steps to prevent interruption of your telephone service.

Your phone might cause TV or radio interference even when it is operating properly. To determine whether your phone is causing the interference, turn off your phone. If the interference goes away, your phone is causing it. Try to eliminate the interference by:

- moving your phone away from the receiver
- connecting your phone to an AC outlet that is on a different electrical circuit from the receiver
- contacting your local RadioShack store for help

If you cannot eliminate the interference, the FCC requires that you stop using your phone.

Some cordless telephones operate on frequencies that might cause interference to nearby TVs and VCRs. To minimize or prevent such interference, the base of the cordless telephone should not be placed near or on top of a TV or VCR.

## **LIGHTNING**

Your telephone has built-in lightning protection to reduce the risk of damage from surges in telephone line and power line current. This lightning protection meets or exceeds FCC requirements. However, lightning striking the telephone or power lines can damage your telephone.

Lightning damage is not common. Nevertheless, if you live in an area that has severe electrical storms, we suggest that you unplug your phone during storms to reduce the possibility of damage.

## **NOTES**

---

---



### Limited One-Year Warranty

This product is warranted by RadioShack against manufacturing defects in material and workmanship under normal use for one (1) year from the date of purchase from RadioShack company-owned stores and authorized RadioShack franchisees and dealers. EXCEPT AS PROVIDED HEREIN, RadioShack MAKES NO EXPRESS WARRANTIES AND ANY IMPLIED WARRANTIES, INCLUDING THOSE OF MERCHANTABILITY AND FITNESS FOR A PARTICULAR PURPOSE, ARE LIMITED IN DURATION TO THE DURATION OF THE WRITTEN LIMITED WARRANTIES CONTAINED HEREIN. EXCEPT AS PROVIDED HEREIN, RadioShack SHALL HAVE NO LIABILITY OR RESPONSIBILITY TO CUSTOMER OR ANY OTHER PERSON OR ENTITY WITH RESPECT TO ANY LIABILITY, LOSS OR DAMAGE CAUSED DIRECTLY OR INDIRECTLY BY USE OR PERFORMANCE OF THE PRODUCT OR ARISING OUT OF ANY BREACH OF THIS WARRANTY, INCLUDING, BUT NOT LIMITED TO, ANY DAMAGES RESULTING FROM INCONVENIENCE, LOSS OF TIME, DATA, PROPERTY, REVENUE, OR PROFIT OR ANY INDIRECT, SPECIAL, INCIDENTAL, OR CONSEQUENTIAL DAMAGES, EVEN IF RadioShack HAS BEEN ADVISED OF THE POSSIBILITY OF SUCH DAMAGES.

Some states do not allow the limitations on how long an implied warranty lasts or the exclusion of incidental or consequential damages, so the above limitations or exclusions may not apply to you.

In the event of a product defect during the warranty period, take the product and the RadioShack sales receipt as proof of purchase date to any RadioShack store. RadioShack will, at its option, unless otherwise provided by law: (a) correct the defect by product repair without charge for parts and labor; (b) replace the product with one of the same or similar design; or (c) refund the purchase price. All replaced parts and products, and products on which a refund is made, become the property of RadioShack. New or reconditioned parts and products may be used in the performance of warranty service. Repaired or replaced parts and products are warranted for the remainder of the original warranty period. You will be charged for repair or replacement of the product made after the expiration of the warranty period.

This warranty does not cover: (a) damage or failure caused by or attributable to acts of God, abuse, accident, misuse, improper or abnormal usage, failure to follow instructions, improper installation or maintenance, alteration, lightning or other incidence of excess voltage or current; (b) any repairs other than those provided by a RadioShack Authorized Service Facility; (c) consumables such as fuses or batteries; (d) cosmetic damage; (e) transportation, shipping or insurance costs; or (f) costs of product removal, installation, set-up service adjustment or reinstallation.

This warranty gives you specific legal rights, and you may also have other rights which vary from state to state.

RadioShack Customer Relations, 200 Taylor Street, 6th Floor, Fort Worth, TX 76102

*We Service What We Sell*

04/99

**RadioShack**  
**A Division of Tandy Corporation**  
**Fort Worth, Texas 76102**

07A99

UCZZ01641BX  
Printed in the Philippines