

**KHS1822 / CH1822**

---

**SPLIT SYSTEM AIR CONDITIONER**

Indoor Unit

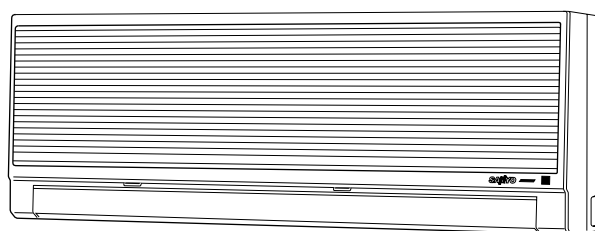

**KHS1822**



Outdoor Unit

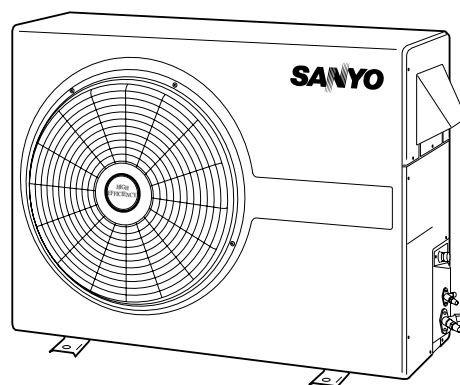

**CH1822**



# **SERVICE MANUAL**

**KHS1822 / CH1822**

**(Basic Information)**

## IMPORTANT! Please Read Before Starting

This air conditioning system meets strict safety and operating standards. As the installer or service person, it is an important part of your job to install or service the system so it operates safely and efficiently.

### For safe installation and trouble-free operation, you must:

- Carefully read this instruction booklet before beginning
- Follow each installation or repair step exactly as shown
- Observe all local, state, and national electrical codes
- Pay close attention to all warning and caution notices given in this manual



#### WARNING:

This symbol refers to a hazard or unsafe practice which can result in severe personal injury or death.



#### CAUTION:

This symbol refers to a hazard or unsafe practice which can result in personal injury or product or property damage.

### If Necessary, Get Help

These instructions are all you need for most installation sites and maintenance conditions. If you require help for a special problem, contact our sales/service outlet or your certified dealer for additional instructions.

### In Case of Improper Installation

The manufacturer shall in no way be responsible for improper installation or maintenance service, including failure to follow the instructions in this document.

---

## SPECIAL PRECAUTIONS

---

### When Wiring

**ELECTRICAL SHOCK CAN CAUSE SEVERE PERSONAL INJURY OR DEATH. ONLY A QUALIFIED, EXPERIENCED ELECTRICIAN SHOULD ATTEMPT TO WIRE THIS SYSTEM.**

- Do not supply power to the unit until all wiring and tubing are completed or reconnected and checked.
- Highly dangerous electrical voltages are used in this system. Carefully refer to the wiring diagram and these instructions when wiring. Improper connections and inadequate grounding can cause **accidental injury or death**.
- **Ground the unit** following local electrical codes.
- Connect all wiring tightly. Loose wiring may cause overheating at connection points and a possible fire hazard.

### When Transporting

Be careful when picking up and moving the indoor and outdoor units. Get a partner to help, and bend your knees when lifting to reduce strain on your back. Sharp edges or thin aluminum fins on the air conditioner can cut your fingers.

### When Installing...

#### ...In a Ceiling or Wall

Make sure the ceiling/wall is strong enough to hold the unit's weight. It may be necessary to construct a strong wood or metal frame to provide added support.

#### ...In a Room

Properly insulate any tubing run inside a room to prevent "sweating" that can cause dripping and water damage to walls and floors.

#### ...In Moist or Uneven Locations

Use a raised concrete pad or concrete blocks to provide a solid, level foundation for the outdoor unit. This prevents water damage and abnormal vibration.

#### ...In an Area with High Winds

Securely anchor the outdoor unit down with bolts and a metal frame. Provide a suitable air baffle.

#### ...In a Snowy Area (for Heat Pump-type Systems)

Install the outdoor unit on a raised platform that is higher than drifting snow. Provide snow vents.

### When Connecting Refrigerant Tubing

- Keep all tubing runs as short as possible.
- Use the flare method for connecting tubing.
- Apply refrigerant lubricant to the matching surfaces of the flare and union tubes before connecting them, then tighten the nut with a torque wrench for a leak-free connection.
- Check carefully for leaks before starting the test run.

#### NOTE:

Depending on the system type, liquid and gas lines may be either narrow or wide. Therefore, to avoid confusion the refrigerant tubing for your particular model is specified as either "narrow" or "wide" rather than as "liquid" or "gas."

### When Servicing

- Turn the power OFF at the main power box (mains) before opening the unit to check or repair electrical parts and wiring.
- Keep your fingers and clothing away from any moving parts.
- Clean up the site after you finish, remembering to check that no metal scraps or bits of wiring have been left inside the unit being serviced.

# Table of Contents

	Page
<b>1. OPERATING RANGE</b> .....	1
<b>2. SPECIFICATIONS</b> .....	2
Unit Specifications .....	2
<b>3. DIMENSIONAL DATA</b> .....	3
<b>4. COOLING CAPACITY</b> .....	4
<b>5. HEATING CAPACITY</b> .....	6
<b>6. REFRIGERANT FLOW DIAGRAM</b> .....	8
<b>7. ELECTRICAL DATA</b> .....	9
● Electrical Characteristics .....	9
● Electric Wiring Diagram.....	10

# 1. OPERATING RANGE

KHS1822 / CH1822

	<b>Temperature</b>	<b>Indoor Air Intake Temp.</b>	<b>Outdoor Air Intake Temp.</b>
Cooling	Maximum	95°F DB / 71°F WB	115°F DB
	Minimum	67°F DB / 57°F WB	67°F DB
Heating	Maximum	80°F DB / 67°F WB	75°F DB / 65°F WB
	Minimum	— DB / — WB	17°F DB / 15°F WB

## 2. SPECIFICATIONS

### Unit Specifications

Model No.		Indoor unit		KHS1822	
		Outdoor unit		CH1822	
Performance	Capacity	BTU/h	Cooling		Heating
		kW	16,500 / 16,000		18,000 / 17,600
	Air circulation (High)	cu. ft./min.	440 / 420		
	Moisture removal (High)	Pints/h	5.3 / 5.2		
Electrical Rating	Phase, Frequency	Hz	Single, 60		
	Voltage rating	V	230 / 208		230 / 208
	Available voltage range	V	187 to 253		187 to 253
	Running amperes	A	8.0 / 8.6		8.0 / 8.6
	Power input	W	1,810 / 1,760		1,810 / 1,760
	Power factor	%	98 / 98		98 / 98
	Starting amperes	A	52		
	S.E.E.R. (H.S.P.F.)	BTU/Wh	10.0 / 10.0		(6.8 / 6.8)
Heat element	kW	—		1.80 / 1.47	
Features	Controls	Microprocessor			
	Control unit	Wireless remote control unit			
	Temperature control	IC thermostat			
	Timer	ON/OFF 24-hours & Program			
	Fan speeds	Indoor / Outdoor	3 and Auto / 1		
	Air deflector	Horizontal / Vertical	Manual / Automatic		
	Air filter	Washable, easy access			
	Compressor	Rotary			
	Refrigerant amount charged at shipment	lbs. (kg)	R22: 4.25 (1.93)		
	Refrigerant control	Capillary tube			
	Refrigerant tubing connections	Flare type			
	Operation sound	In-Hi / Me / Lo	dB-A	47 / 44 / 40	
		Out-Hi	dB-A	55	
	Max. allowable tubing length at shipment	ft. (m)	33 (10)		
	Limit of tubing length	ft. (m)	65 (20)		
	Limit of elevation difference between the 2 units	ft. (m)	Outdoor unit is higher than indoor unit: 23 (7) Outdoor unit is lower than indoor unit: 23 (7)		
Refrigerant tube o.d.	Narrow tube	in. (mm)	1/4 (6.35)		
	Wide tube	in. (mm)	5/8 (15.88)		
Refrigerant tube kit	Optional				
Accessories	Hanging wall bracket				
Dimensions & Weight			Indoor unit	Outdoor unit	
	Height	in. (mm)	14-3/16 (360)		24-13/16 (630)
	Width	in. (mm)	38-31/32 (990)		32-11/16 (830)
	Depth	in. (mm)	7-25/32 (198)		12-13/32 (315)
	Net weight	lbs. (kg)	30 (13.5)		134 (61)
	Shipping volume	cu. ft. (cu. m)	4.8 (0.136)		10.4 (0.294)
Shipping weight (Approx.)	lbs. (kg)	37.4 (17)		143 (65)	

DATA SUBJECT TO CHANGE WITHOUT NOTICE.

**Remarks:** Rating conditions are:

- Cooling: Outside air temperature 95°F DB/75°F WB  
Indoor unit entering air temperature 80°F DB/67°F WB
- Heating: Outside air temperature 47°F DB/43°F WB  
Indoor unit entering air temperature 70°F WB

### 3. DIMENSIONAL DATA

#### Indoor Unit: KHS1822

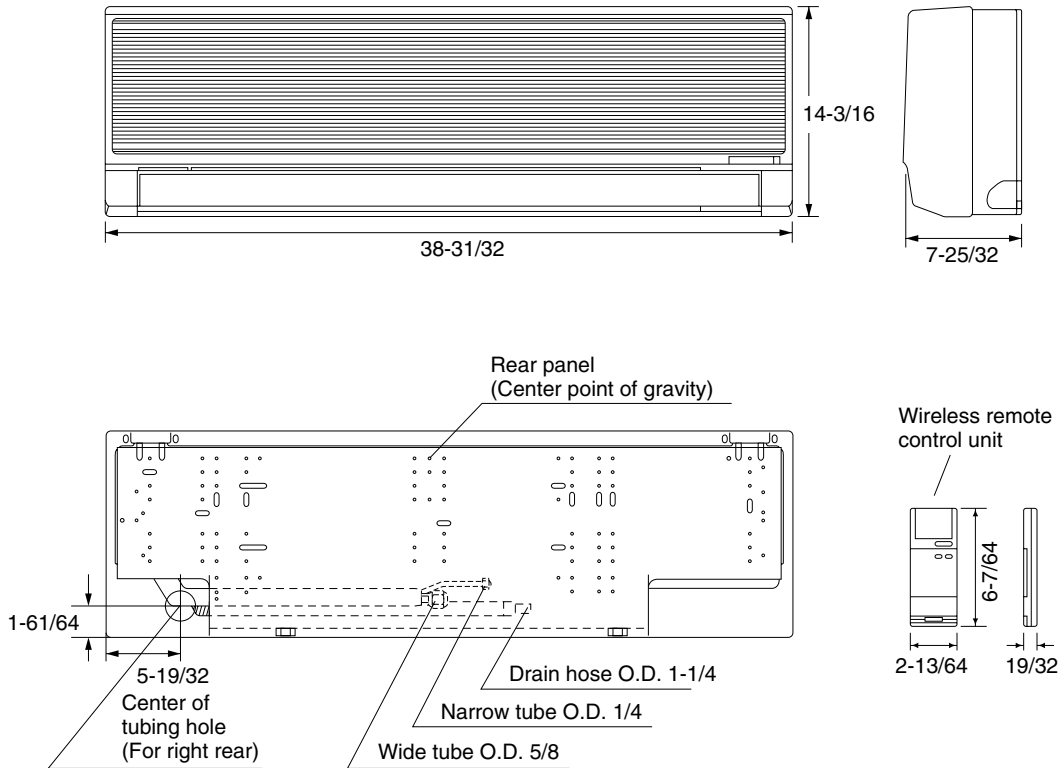

#### Outdoor Unit: CH1822

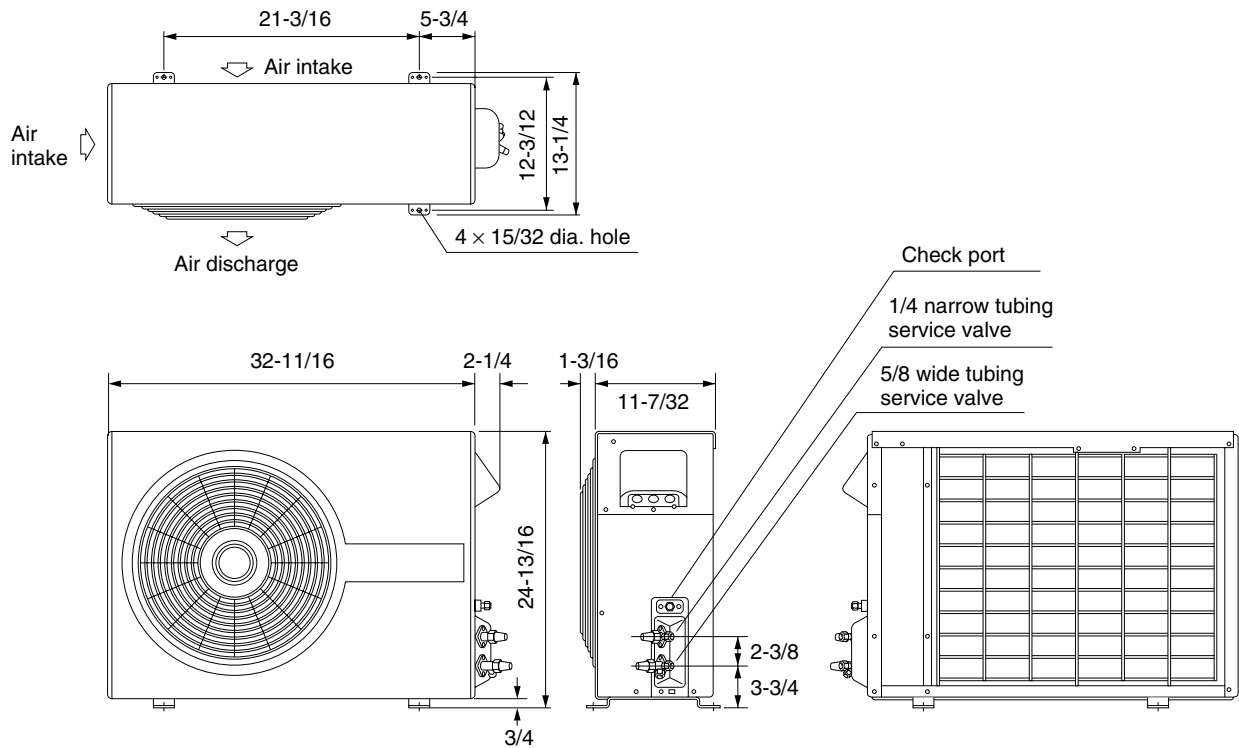



## 4. COOLING CAPACITY

230V

KHS1822 / CH1822

Rating Capacity: 16,500 BTU/H			Air Flow Rate: 440 CFM				
Evaporator		Condenser					
Ent. Temp. °F/(°C)		Ambient Temp. °F/(°C)					
WB	DB		75 (23.9)	85 (29.4)	95 (35.0)	105 (40.6)	115 (46.1)
59 (15.0)		TC	16,340	15,590	14,850	14,010	12,870
		kW	1.31	1.43	1.56	1.69	1.86
	72 (22.2)	SHC	11,540	11,140	10,750	10,320	9,760
	76 (24.4)	SHC	12,910	12,510	12,130	11,700	11,130
	80 (26.7)	SHC	14,340	13,950	13,560	13,130	12,560
	84 (28.9)	SHC	15,720	15,320	14,850	14,010	12,870
63 (17.2)		TC	16,900	16,370	15,720	14,870	13,700
		kW	1.32	1.45	1.58	1.72	1.90
	72 (22.2)	SHC	9,780	9,520	9,210	8,810	8,270
	76 (24.4)	SHC	11,150	10,890	10,580	10,180	9,640
	80 (26.7)	SHC	12,590	12,330	12,020	11,610	11,070
	84 (28.9)	SHC	13,960	13,700	13,390	12,990	12,440
67 (19.4)		TC	17,360	17,080	*16,500	15,590	14,520
		kW	1.34	1.46	1.60	1.74	1.94
	72 (22.2)	SHC	7,960	7,840	7,580	7,190	6,730
	76 (24.4)	SHC	9,330	9,210	8,950	8,560	8,100
	80 (26.7)	SHC	10,770	10,640	10,390	9,990	9,540
	84 (28.9)	SHC	12,140	12,010	11,760	11,370	10,910
71 (21.7)		TC	17,900	17,610	17,160	16,380	15,430
		kW	1.35	1.48	1.62	1.79	1.98
	72 (22.2)	SHC	6,090	5,970	5,790	5,490	5,120
	76 (24.4)	SHC	7,460	7,340	7,170	6,860	6,490
	80 (26.7)	SHC	8,900	8,780	8,600	8,300	7,930
	84 (28.9)	SHC	10,270	10,150	9,970	9,670	9,300
75 (23.9)		TC	18,250	18,050	17,660	17,030	16,340
		kW	1.38	1.50	1.65	1.83	2.02
	76 (24.4)	SHC	5,600	5,530	5,380	5,160	4,920
	80 (26.7)	SHC	7,030	6,960	6,820	6,590	6,350
	84 (28.9)	SHC	8,400	8,330	8,190	7,970	7,720
	88 (31.1)	SHC	9,780	9,700	9,560	9,340	9,100

TC: Total Cooling Capacity (BTU/H)  
 SHC: Sensible Heat Capacity (BTU/H)  
 kW: Compressor Input (kW)

**Remarks:** Rating conditions (\* mark) are: Outdoor ambient temperature 95°F DB  
 Indoor unit entering air temperature 80°F DB/67°F WB

Rating Capacity: 16,000 BTU/H			Air Flow Rate: 420 CFM				
Evaporator		Condenser					
Ent. Temp. °F/(°C)		Ambient Temp. °F/(°C)					
WB	DB		75 (23.9)	85 (29.4)	95 (35.0)	105 (40.6)	115 (46.1)
59 (15.0)		TC	15,840	15,120	14,400	13,580	12,480
		kW	1.28	1.40	1.52	1.65	1.81
	72 (22.2)	SHC	11,180	10,800	10,420	10,000	9,450
	76 (24.4)	SHC	12,500	12,120	11,740	11,320	10,770
	80 (26.7)	SHC	13,880	13,500	13,120	12,700	12,150
	84 (28.9)	SHC	15,200	14,820	14,400	13,580	12,480
	88 (31.1)	SHC	15,840	15,120	14,400	13,580	12,480
63 (17.2)		TC	16,380	15,870	15,250	14,420	13,280
		kW	1.29	1.42	1.54	1.68	1.85
	72 (22.2)	SHC	9,490	9,240	8,930	8,540	8,010
	76 (24.4)	SHC	10,810	10,560	10,250	9,860	9,330
	80 (26.7)	SHC	12,190	11,940	11,640	11,240	10,720
	84 (28.9)	SHC	13,510	13,260	12,960	12,560	12,040
	88 (31.1)	SHC	14,830	14,580	14,280	13,880	13,280
67 (19.4)		TC	16,830	16,560	*16,000	15,120	14,080
		kW	1.30	1.43	1.56	1.70	1.89
	72 (22.2)	SHC	7,730	7,610	7,360	6,980	6,540
	76 (24.4)	SHC	9,050	8,930	8,680	8,300	7,860
	80 (26.7)	SHC	10,430	10,310	10,060	9,680	9,240
	84 (28.9)	SHC	11,750	11,630	11,380	11,000	10,560
	88 (31.1)	SHC	13,080	12,950	12,710	12,320	11,880
71 (21.7)		TC	17,360	17,070	16,640	15,890	14,960
		kW	1.32	1.44	1.58	1.75	1.93
	72 (22.2)	SHC	5,930	5,810	5,640	5,340	4,980
	76 (24.4)	SHC	7,250	7,130	6,960	6,660	6,300
	80 (26.7)	SHC	8,630	8,520	8,340	8,050	7,690
	84 (28.9)	SHC	9,950	9,840	9,660	9,370	9,010
	88 (31.1)	SHC	11,270	11,160	10,980	10,690	10,330
75 (23.9)		TC	17,700	17,500	17,120	16,510	15,840
		kW	1.34	1.47	1.61	1.79	1.97
	76 (24.4)	SHC	5,450	5,380	5,240	5,020	4,790
	80 (26.7)	SHC	6,830	6,760	6,620	6,410	6,170
	84 (28.9)	SHC	8,150	8,080	7,940	7,730	7,490
	88 (31.1)	SHC	9,470	9,400	9,260	9,050	8,810

TC: Total Cooling Capacity (BTU/H)  
 SHC: Sensible Heat Capacity (BTU/H)  
 kW: Compressor Input (kW)

**Remarks:** Rating conditions (\* mark) are: Outside ambient temperature 95°F DB  
 Indoor unit entering air temperature 80°F DB/67°F WB

# 5. HEATING CAPACITY

1 Phase 60Hz 230V

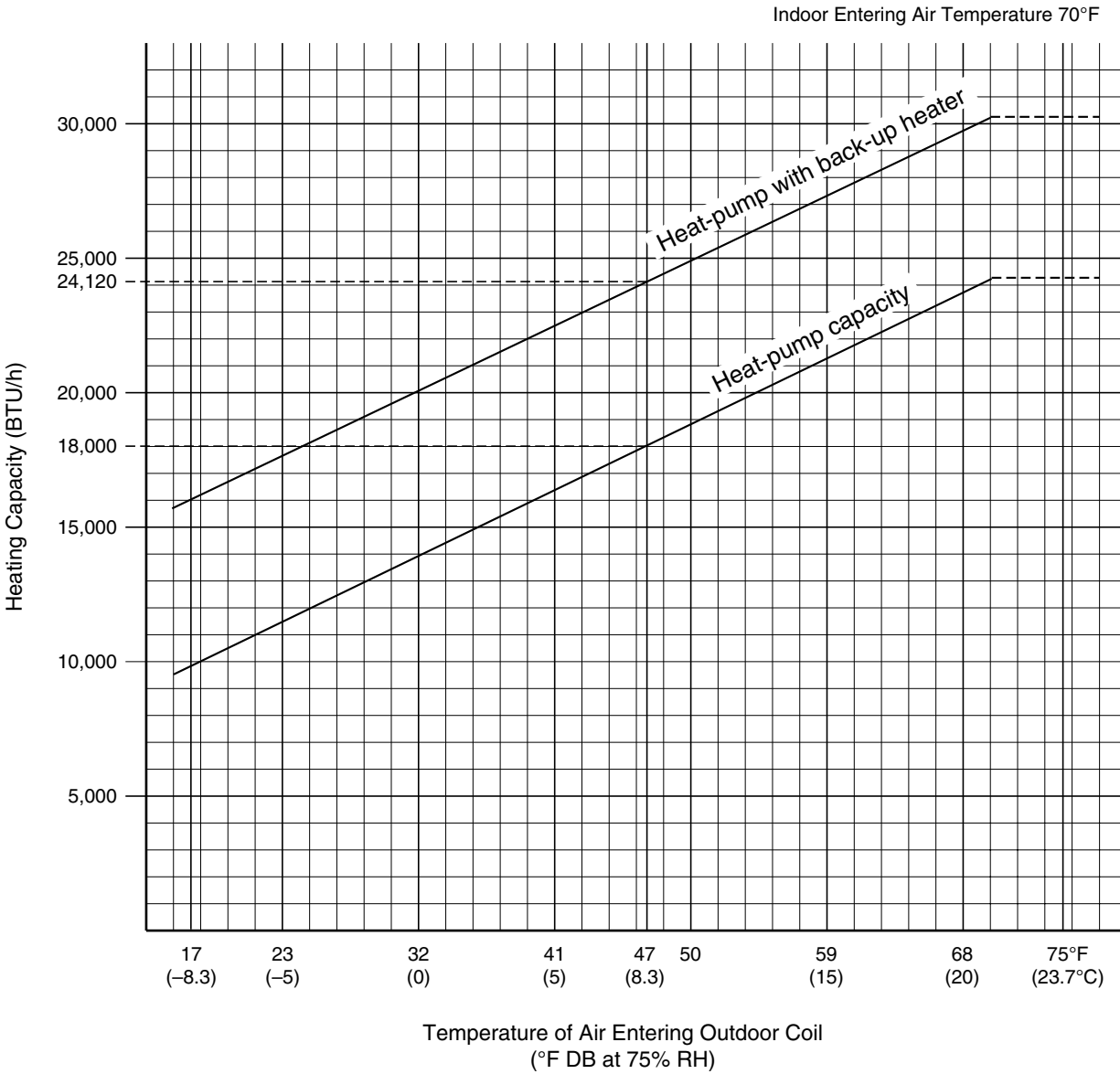

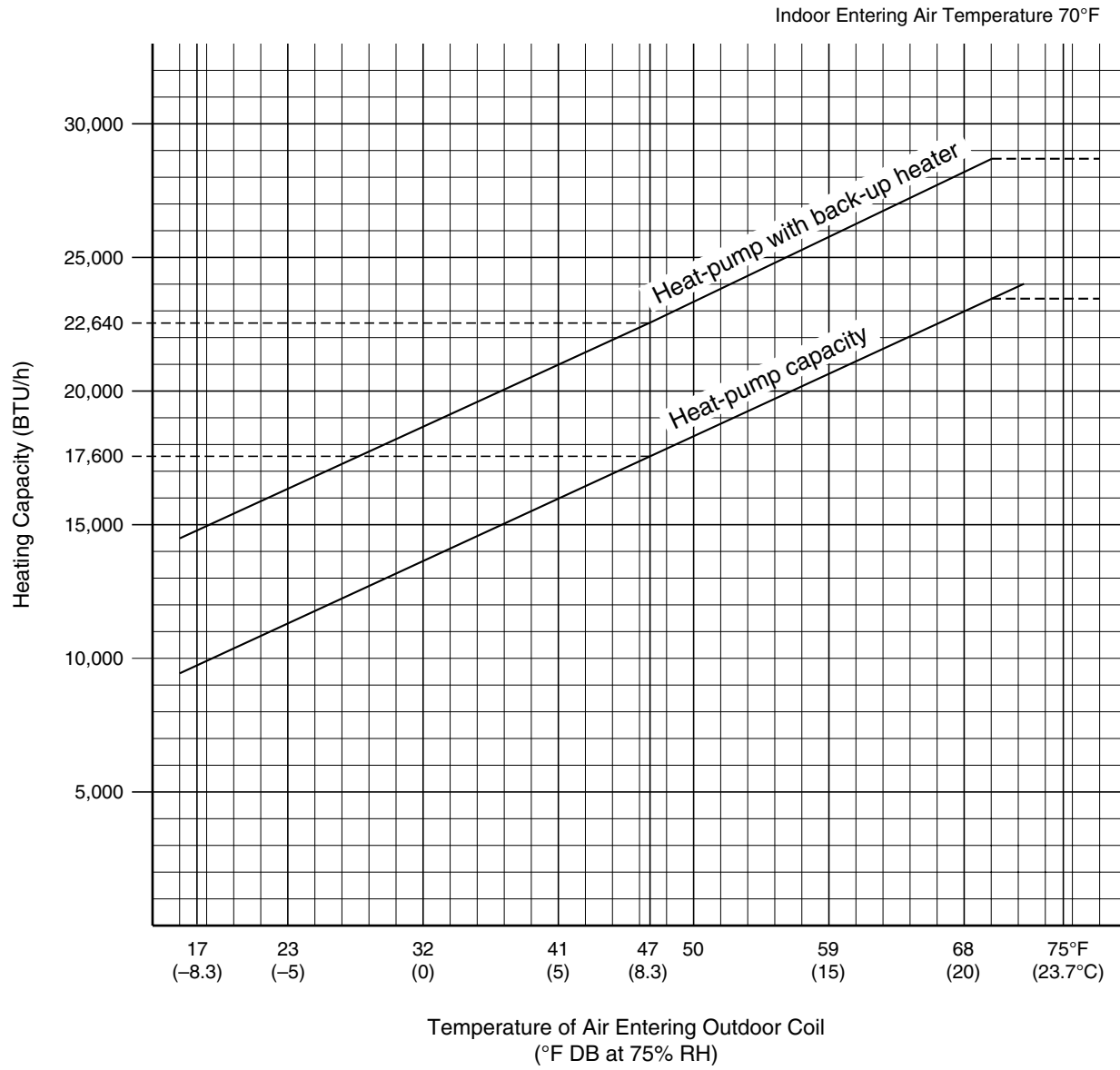

# 6. REFRIGERANT FLOW DIAGRAM

## Cooling Cycle

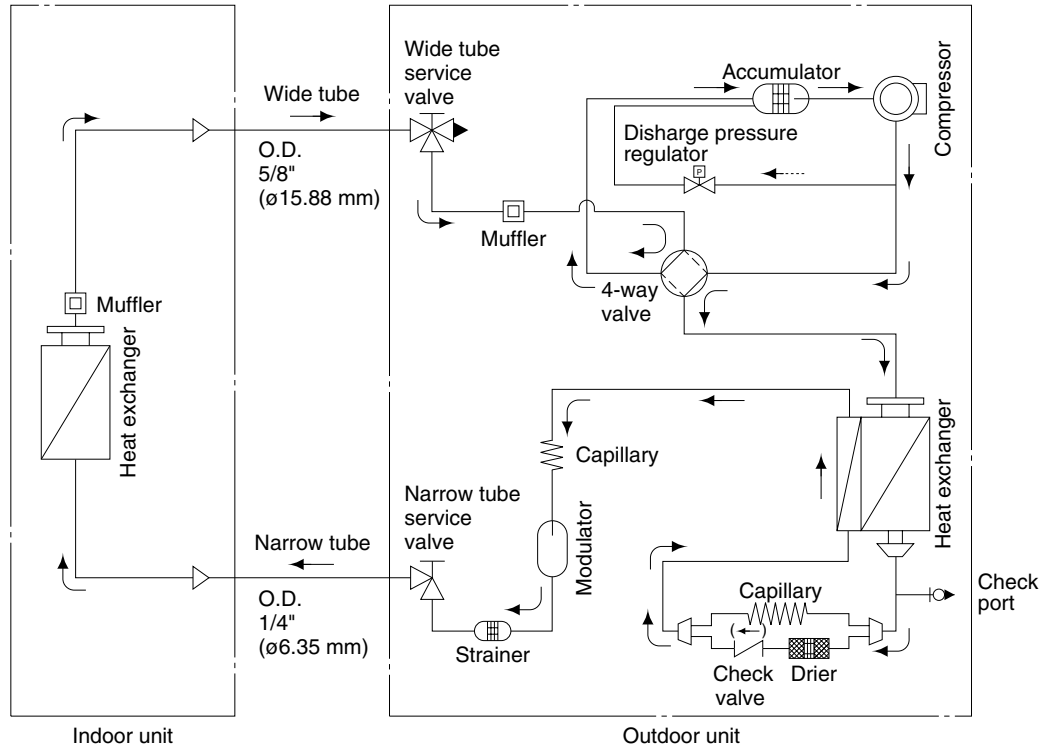

## Heating Cycle

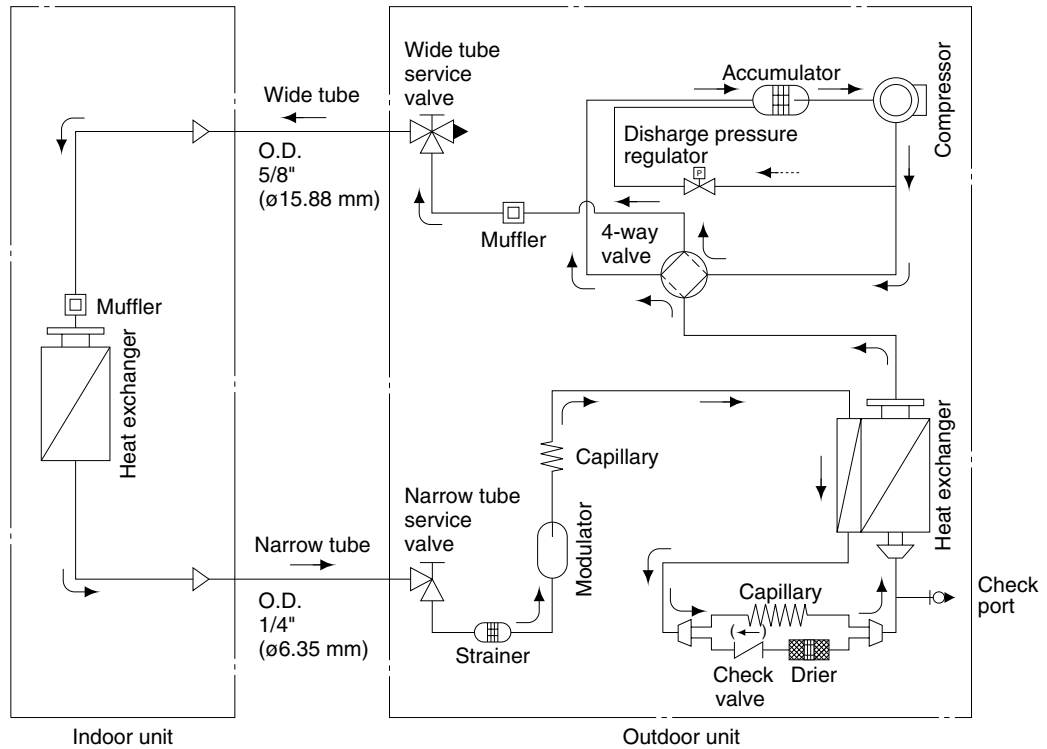

## 7. ELECTRICAL DATA

### ● Electrical Characteristics

KHS1822 / CH1822

Performance at 230/208V – 1Ø – 60Hz			Indoor Unit		Outdoor Unit		Complete Unit	
			Fan Motor	Max. Heat	Fan Motor	Compressor	Heat-pump	Max. Heat
Cooling	Rating Conditions	A	0.40 / 0.40	—	0.47 / 0.47	7.13 / 7.73	8.0 / 8.6	—
		W	90 / 81	—	105 / 95	1,595 / 1,564	1,790 / 1,740	—
Heating	Rating Conditions	A	0.40 / 0.40	7.8 / 7.1	0.47 / 0.47	7.13 / 7.73	8.0 / 8.6	15.8 / 15.7
		W	90 / 81	1,800 / 1,470	105 / 95	1,595 / 1,574	1,790 / 1,750	3,590 / 3,220
Locked-Rotor Amperes		A	0.45 / 0.40	—	0.71 / 0.64	52	—	—

**Remarks:** Rating conditions are:

Cooling: Outside air temperature 95°F DB/75°F WB

Indoor unit entering air temperature 80°F DB/67°F WB

Heating: Outside air temperature 47°F DB/43°F WB

Indoor unit entering air temperature 70°F WB

● Electric Wiring Diagram

Indoor Unit: KHS1822

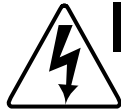

**WARNING:**

*To avoid electrical shock hazard, be sure to disconnect power before checking, servicing and/or cleaning any electrical parts.*

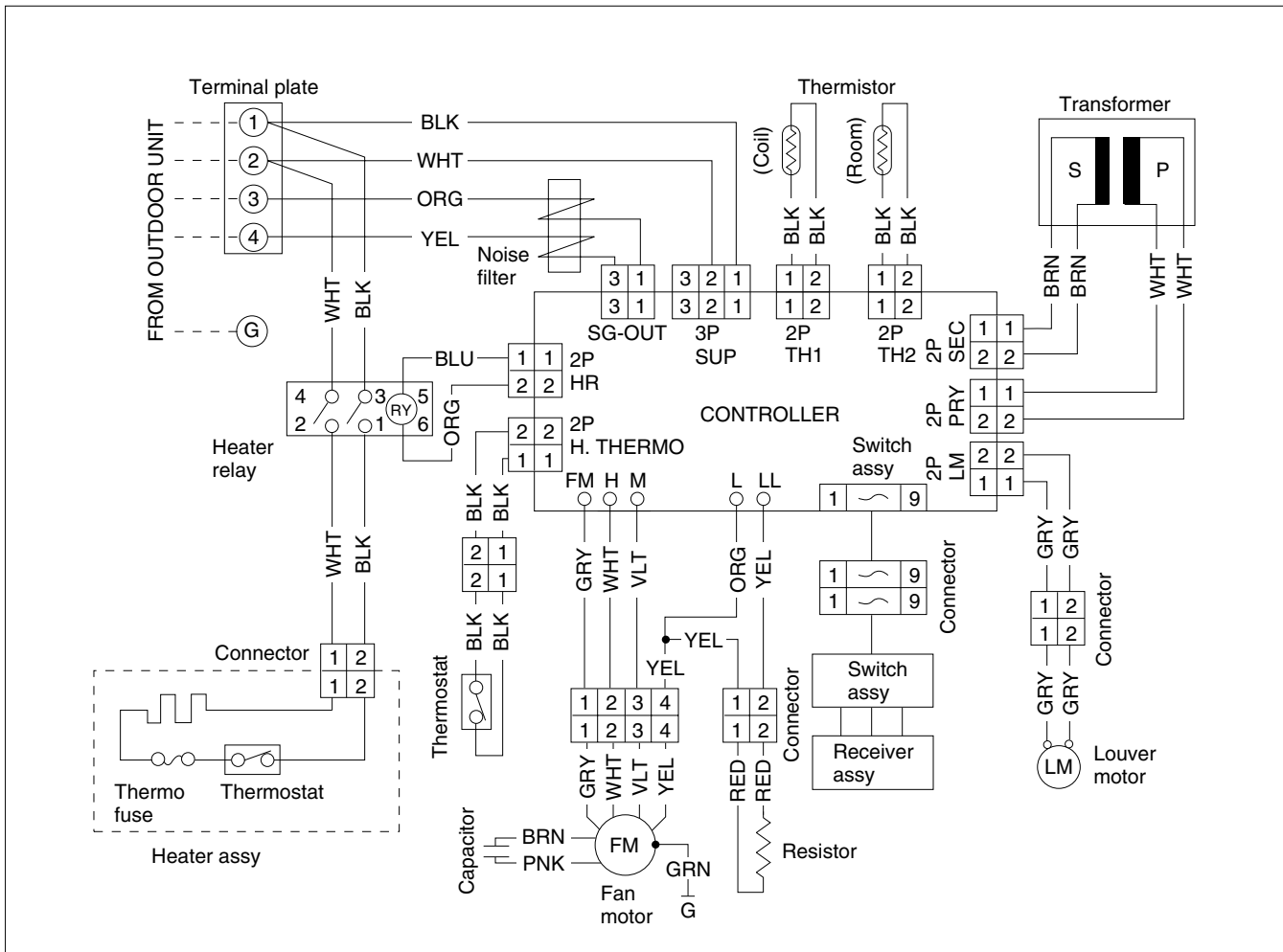



**WARNING:**

*To avoid electrical shock hazard, be sure to disconnect power before checking, servicing and/or cleaning any electrical parts.*

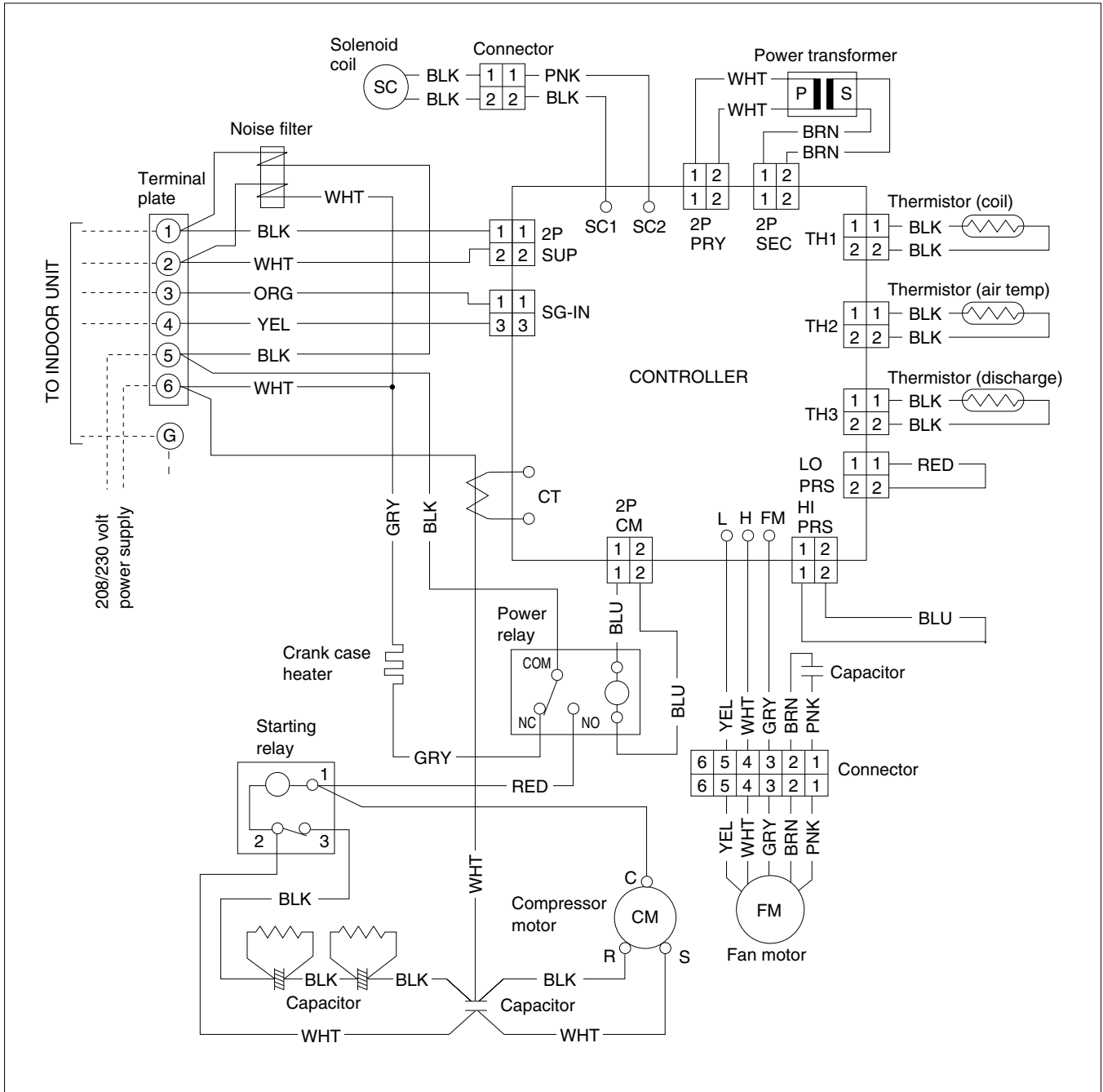



For parts or service contact



**SFS Corporation: 1200 West Artesia Blvd., Compton, California 90220**

**In Canada SANYO Canada Inc.: Toronto, Ont. M4H 1M6**

H408/12M

Printed in U.S.A.

WM-700796