



SONANCE MERLOT®  
MR/SSMR-SERIES  
IN-CEILING SPEAKERS

---

INSTRUCTION MANUAL



## Introduction

Thank you for purchasing Sonance Merlot® MR and SSMR-series in-ceiling speakers. When properly installed your new speakers will give you years of entertainment pleasure. This manual will teach you all about your new speakers' many innovative features and will show you how to get the very best performance from them. Please read it thoroughly.

Since all of the Merlot MR/SSMR-series speakers have identical installation requirements, the directions in this manual apply to each model in the series. This manual covers the Merlot 422MR, Merlot 421MR and 421SSMR.

### SAFETY WARNING:

These speakers have FastMount® tabs that prevent the speaker from falling out of the mounting hole during the installation process.

**THE EDGES OF THE FASTMOUNT TABS ARE VERY SHARP.  
USE CAUTION WHEN HANDLING THE SPEAKER.**

See *Installation* (page 9) for complete information about the FastMount tabs.

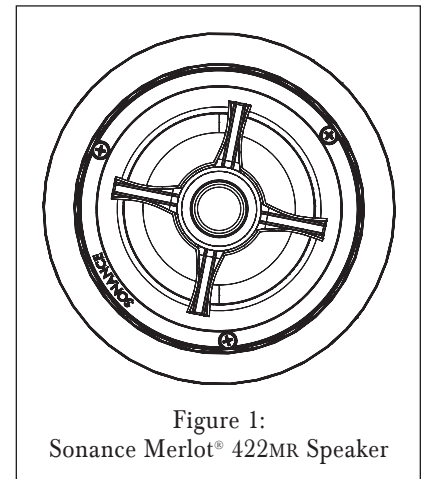

Figure 1:  
Sonance Merlot® 422MR Speaker

## Design and Features

- Small footprint lets you install Merlot speakers in places that present installation challenges while delivering sonic performance that will satisfy demanding listeners.
- Ideal for use in multi-channel home theater systems and stereo music systems.
- 421SSMR features Single Stereo Technology® — reproducing left & right stereo channels from a single speaker — ideal for use in areas where space is limited.
- Advanced woofer cone materials create strong, low-distortion bass.
- The FastMount® tabs and RotoLock® mounting system make installation quick and easy.

## Box Contents

Your Sonance MR Merlot speaker box should contain the following items:

- |                        |   |
|------------------------|---|
| (2) Merlot MR speakers | (2) Plastic paint plugs (installed on fronts of speakers) |
| (2) Paintable grilles  | (1) Mounting cutout template (in packaging)               |

Your Sonance MR Merlot speaker box should contain the following items:

- |                         |  |
|-------------------------|--|
| (1) Merlot SSMR speaker | (1) Plastic paint plug (installed on front of speaker) |
| (1) Paintable grille    | (1) Mounting cutout template (in packaging)            |

## Speaker Placement

When selecting mounting locations for your speakers you should consider such things as your primary listening location, the primary use for the speakers (distributed audio, 2-channel stereo or home theater) and aesthetic values. Your local authorized Sonance dealer is an expert in audio/video system planning and installation. We strongly recommend that you work with your dealer to ensure that your system is properly planned, assembled and installed.

### Distributed Audio Speaker Placement (Mono signal)

Sonance Merlot 421SSMR Single Stereo Technology® speakers are ideal for use in hallways, bathrooms, closets, or in any location where listeners will be moving around and a pair of stereo speakers would be impractical. Because a single SSMR speaker reproduces both stereo channels from a single location, it will deliver outstanding performance from an extremely wide variety of mounting locations.

All Sonance Merlot MR and SSMR-series speaker models have very smooth and predictable off-axis response, so they provide excellent coverage in distributed audio systems from a wide variety of installation locations. The chart in *Figure 1* shows how far apart the speakers can be placed at different ceiling heights while still providing good coverage (as shown in *Figure 2*). The distances are based on ear heights of 62" for standing listeners and 40" for seated listeners.

SPEAKER SPACING (IN FEET) FOR A DISTRIBUTED AUDIO SYSTEM		
	STANDING LISTENER	SEATED LISTENER
8-FOOT CEILING	5.7 Feet Apart	9.5 Feet Apart
10-FOOT CEILING	9.7 Feet Apart	13.5 Feet Apart
12-FOOT CEILING	13.7 Feet Apart	17.5 Feet Apart
14-FOOT CEILING	17.7 Feet Apart	21.5 Feet Apart

Figure 1: Distributed Audio Speaker Spacing

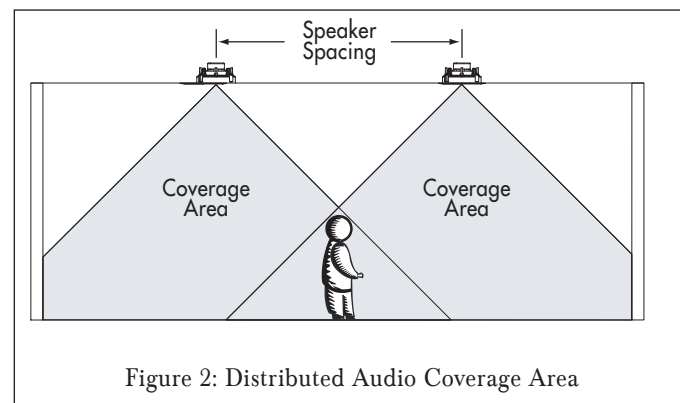

### Stereo Speaker Placement

- Place the left and right speakers anywhere from 6 feet to 10 feet apart, with the main listening position as close to midway between the speakers as possible.
- The speakers should be 38 – 42 inches from the floor and at least 18 inches away from the side walls.
- The main listening position should be between 4 and 10 feet away from the speakers.
- For the 422MR, pivoting the tweeter of each speaker directly towards the main listening position will help maximize the stereo soundstage.

Use the left and right speaker placement in *Figure 3* (on page 5) as a guide.

## Home Theater Speaker Placement

### Left, Center & Right Channels

Place the left & right speakers from 1 foot to 2 feet in front of the video screen, anywhere from 6 feet to 10 feet apart, with the center channel speaker as close to midway between the left and right speakers as possible.

- The left and right speakers should be at least 2 feet away from the side walls.
- The main listening position should be between 4 and 10 feet away from the speakers.
- For the 422MR, pivoting the tweeters towards the listening position will help maximize clarity.

Use *Figure 3* as a guide.

### Left & Right Surround Channels (5.1-Channel System)

Locate the left and right surround channel speakers on the ceiling between 2 and 6 feet behind the listening position. The speakers should be between 6 and 10 feet apart. Since the surround speakers are usually called-upon to reproduce diffuse effects like the sound of wind or rain you can mount them close to walls without adversely affecting sound quality.

Use *Figure 3* as a guide.

### Left & Right Surround and Surround Back Channels (7.1-Channel System)

**Left & Right Surround Speakers:** Place the left and right surround speakers directly to the sides of the listening position, between 6 and 10 feet apart. The speakers can be placed close to the side walls.

**Surround Back Speakers:** Place the surround back speakers between 2 and 6 feet behind the listening position. The surround back speakers should be closer together than the left and right surround speakers — between 3 and 6 feet apart.

- Like the left and right surround speakers, the surround back speakers can be located close to walls without adversely affecting sound quality.

Use *Figure 4* as a guide.

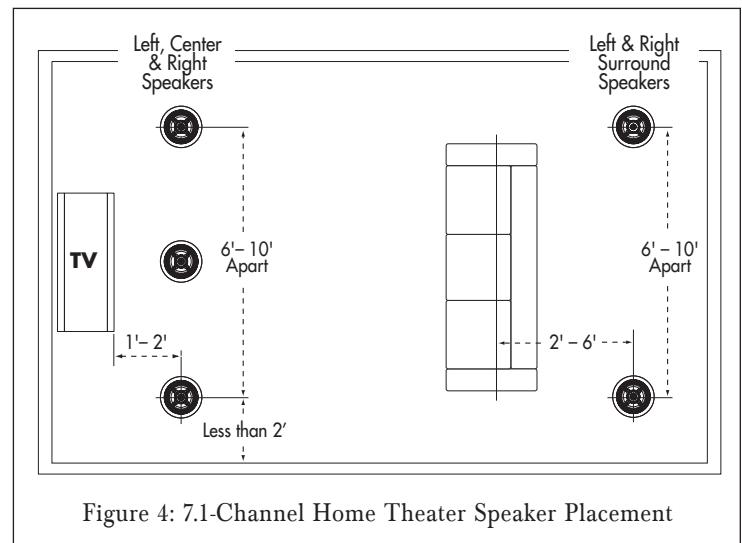
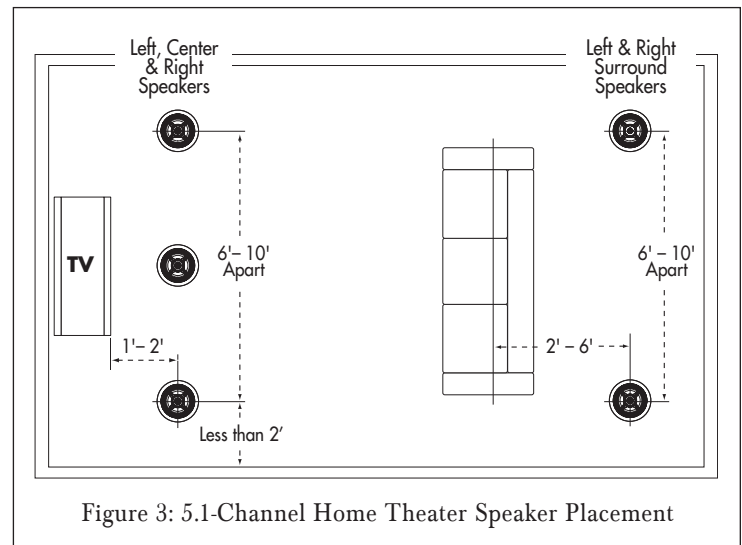

## Selecting the Proper Speaker Wire

For the best sound we recommend that you use premium Sonance MediaLinQ® speaker cable, which also complies with UL fire rating codes. You may also experiment with audiophile brands of speaker cable and interconnects, but be sure to check local codes governing wire that may be installed within walls or ceilings. Different brands of wire can have different sonic characteristics, and some may be more compatible with the sonic “signature” of your various audio system components.

For the best sound you should never use thin-gauge speaker wire – it will constrict the sound and diminish bass response. Extra resistance in the speaker wire can make a speaker sound less dynamic and reduce definition of the bass frequencies. In extreme cases, it can even attenuate high frequencies. Also, amplifier power is wasted in thin wire with extra resistance, reducing your system’s maximum output level. To prevent degrading sound quality, the total wire resistance should be less than 10% of the speaker’s impedance. This means that for an 8-ohm speaker, the total resistance of the wire should be less than 0.8 ohms. Refer to *Figure 5* when selecting the proper wire gauge for your system.

WIRE RESISTANCE IN OHMS VS. LENGTH OF CABLE RUN						
Distance in Feet	50'	100'	150'	200'	250'	300'
<b>20 gauge</b>	1.04	2.07	3.11	4.14	5.18	6.22
<b>18 gauge</b>	.65	1.30	1.96	2.61	3.26	3.91
<b>16 gauge</b>	.41	.82	1.22	1.63	2.04	2.45
<b>14 gauge</b>	.26	.52	.77	1.03	1.29	1.55
<b>12 gauge</b>	.16	.32	.49	.65	.81	.97
<b>10 gauge</b>	.10	.20	.31	.41	.51	.61

Figure 5: Speaker Wire Resistance Table

## Preparing the Installation Location

### Building a Back Box into the Wall Stud Bay

Sonance Merlot MR-series speakers are designed to provide exceptionally musical performance in a wide variety of enclosure volumes. You can get the very best performance from your speakers by partitioning a section of the stud bay to form a sealed back box with a specific internal volume. Building such an enclosure will create a dramatic improvement in your speakers’ bass performance and power handling. The ideal back box volume for the Merlot 422M, 421M and 421SSMR is 0.25 ft<sup>3</sup>.

### Optional Merlot M-Series Speaker Enclosures

For installations where it isn’t possible to partition the stud bay into a back box, installing optional Merlot MR Acoustic Enclosures (part #92445) will noticeably improve your speakers’ bass performance and power handling and will significantly reduce sound transmission into adjacent rooms and spaces. These enclosures are made from ½”-thick MDF and are designed to be installed in new construction only.

To reduce sound transmission into adjacent rooms in installations where it isn’t possible to install a Merlot M Acoustic Enclosure (such as when you’re retrofitting the speakers into an existing wall), you can fit the speakers with optional Merlot MR-Series Retrofit Enclosures (part #92443). This enclosure is designed specifically to be used with Merlot MR and SSMR-series speakers, and will noticeably reduce sound “spillover” from the rears of the speakers into adjacent rooms and spaces.

### Insulating the Ceiling Cavity

You can also reduce sound transmission to adjacent rooms and improve speaker performance by inserting a sheet of unfaced fiberglass insulation over the back of the speaker. To reduce mechanical noise produced by unsupported drywall, install fiberglass insulation in the ceiling bays adjacent to the speaker location.

#### Sonafill®

Sonafill (part #91928) is a retrofittable acoustical treatment system consisting of two pillows and four tiles that virtually eliminates noises produced by resonating drywall. The tiles have pressure-sensitive adhesive and are installed on the back of the drywall on either side of the speaker between the ceiling joists; the pillows are then stuffed in place behind the tiles. The system dramatically improves midbass sound quality and reduces sound transmission into adjacent rooms.

#### Optional Accessories

**Merlot MR FlexBracket (part #91973):** Plastic template to reserve a mounting hole for Merlot MR-series speakers in new construction. Designed for use with the RotoLock® mounting system.

**Merlot MR Acoustic Enclosure (part #92445):** ½" MDF enclosure that provides ideal acoustic performance and maximum reduction of sound transmission into adjacent spaces. Designed for use only in new construction.

**Merlot MR Retrofit Enclosure (part #92443):** Molded enclosure that reduces sound transmission into adjacent rooms and spaces. Can be used in both new construction and retrofit installations.

**Sonafill® In-Ceiling System (part #91928):** Retrofittable acoustical treatment consisting of two pillows and four tiles that virtually eliminates noises produced by resonating drywall. Dramatically improves midbass sound quality and reduces sound transmission into adjacent rooms.

## Installing the Speakers

### Before Installation: New Construction

For installations in new construction, Sonance recommends using a Merlot MR FlexBracket (part #91973) to reserve a location for the speaker. The FlexBracket has perforated wings that can be positioned anywhere around the bracket, and is nailed or screwed to the ceiling joists. This serves as a guide for the drywaller so that the speaker hole will be in the desired location once the drywall is installed.

### Before Installation: Retrofit

1. Determine the location for the speaker (see *Speaker Placement* on page 4).
2. Perform an obstruction survey to be certain that there are no joists, conduit, pipes, heating ducts, or air returns in the ceiling cavity that will interfere with the speaker.
3. The cutout for all Merlot MR and SSMR speakers is 5<sup>7</sup>/<sub>8</sub>" (149mm) in diameter. There also must be at least 3<sup>1</sup>/<sub>2</sub>" (89mm) depth within the ceiling cavity for the speaker.
4. Position the included cutout template where the speaker is to be located and pencil an outline on the ceiling.
  - If you are unsure about obstructions, drill a small hole in the center of the outline and insert a coat hanger wire into the hole to feel-around for possible obstructions.
5. Cut the mounting hole using a keyhole or drywall saw, and run the speaker wires from the mounting hole to the amplifier location.
  - Consult local building codes before running speaker wires through ceilings.

## Installation

Sonance Merlot MR and SSMR speakers feature exclusive FastMount® tabs and an integral RotoLock® mounting system for quick mounting directly into walls.

**CAUTION: THE EDGES OF THE FASTMOUNT TABS ARE VERY SHARP. USE CAUTION WHEN HANDLING THE SPEAKER.**

1. Remove the paint plug from the speaker.
2. Run speaker wire from each speaker to the amplifier location.
3. Strip ¼" – ½" of insulation from each speaker lead. Twist the strands or tin the exposed wire with solder to ensure that there are no stray strands. (Stray strands that touch each other can cause a short-circuit that can damage your amplifier.)
4. The speaker's connector posts are spring-loaded. Push the top of each connector post down to open the connector and insert the exposed wires into the holes in the posts. The 421 SSMR has two sets of connectors, one for the left amplifier channel and one for the right.
  - The speaker's positive post is labeled with a red dot; the negative post is labeled with a black dot. Double-check that you connected amplifier "+" to speaker "+" and amplifier "-" to speaker "-".
5. Make sure all the RotoLock clamps are in the full clockwise position so that they are tucked within the mounting hole's border. Insert the speaker into the hole in the wall (*Figure 6*). The RotoLock system can accommodate a maximum wall material thickness of 1¼".

- The FastMount tabs will prevent the speaker from falling out of the mounting hole, allowing the installer to let go of the speaker to pick-up tools or other items (see *Figure 7*).

*Note: The FastMount tabs are designed for one-time use only. If the speaker is removed from the mounting hole the FastMount tabs will disconnect and remain inside the ceiling.*

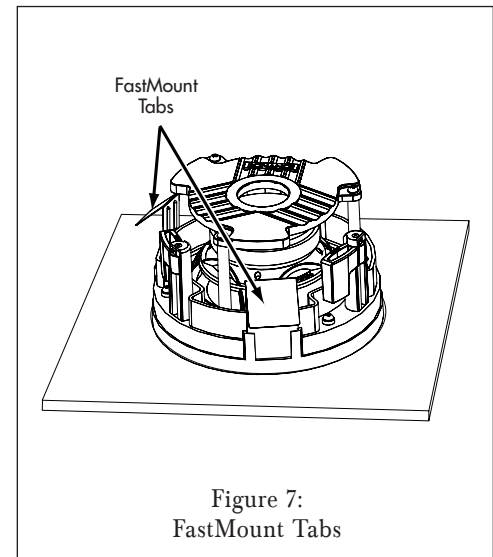
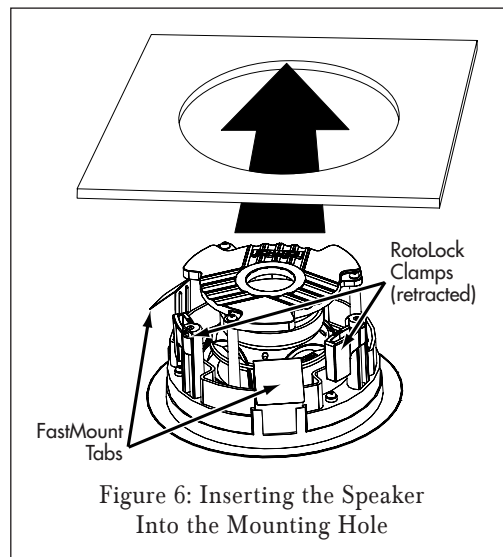



6. Tighten the four screws on the front of the speaker baffle. The RotoLock clamps will automatically rotate into position and begin clamping the speaker (see *Figure 8*).

- When you notice resistance on the screws the speaker has been clamped successfully.

**Important: Always use low-torque settings; NEVER over-tighten.**

*Note: The speaker flange is designed to flex and conform to any small imperfections in the wall surface. Do not tighten the screws so much so that the flange bows-out.*

7. Attach the grille after the speaker has been installed. Insert about half of the grille into the groove at the edge of the speaker. Gently fit the remaining half of the grille by working around the speaker, fitting the grille into the groove as you go.

*Note: You can adjust the torque applied to the RotoLock screws to achieve a proper grille fit.*

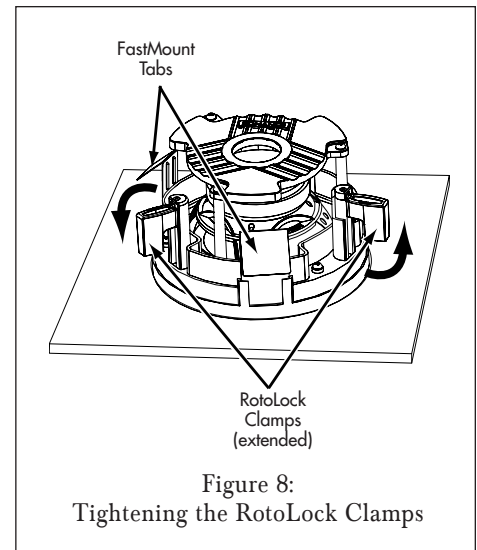

## Painting The Speakers and Grilles

You can paint the speakers and grilles before installing them, which will eliminate the “paint scar” that can be left on the wall if the speaker ever needs to be removed for service. You can also paint the speakers after installation, but before the grilles are attached. All Sonance Merlot speakers come from the factory fitted with a plastic ‘paint plug’ that protects the speaker drivers while the mounting flange is being painted.

Sonance always suggests painting the grille separately from the speaker. Before painting, carefully remove the under-grille cloth. It is held in place with a light tacking glue that makes it easy to remove.

Spray the grilles with thinned paint (5 parts thinner to 1 part paint), being careful not to plug the holes. Too heavy a coat of paint on the grille will adversely affect the sound of the speaker.

Once the grilles and flange are painted and dry, replace the under-grille cloth, remove the paint plug from the mounting flange and install the grille.

## Speaker Adjustments

### Pivoting Tweeter

The Merlot 422MR speaker has a pivoting tweeter that allows you to direct sound towards or away from the listening area, depending on how the speakers are being used:

- If you're using the speakers in stereo or as the front left/center/right speakers in a home theater, pivot the tweeter directly towards the listening area. This will help the sound from the speakers blend into a solid sound-stage even if the speakers are widely separated.
- If you're using the speakers as surround channel speakers in a home theater, you can create a more diffuse, spacious surround effect by pivoting the tweeters towards a wall or window, away from the listeners.

#### To Pivot the Tweeter:

Apply light pressure to the plastic ring around the outside edge of the tweeter dome, as shown in *Figure 9*. Take care not to touch or apply pressure to the tweeter dome itself.

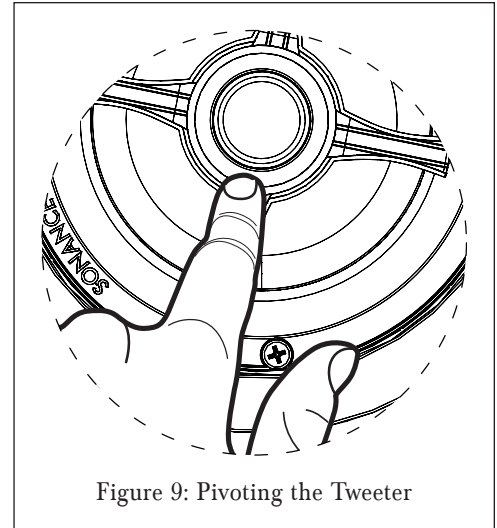

Figure 9: Pivoting the Tweeter

## Specifications

### 422MR

Tweeter:	¾" (19mm) silk dome, pivoting
Woofers:	4½" (114mm) Black polypropylene cone with a rubber surround
Frequency Response:	60Hz – 20kHz ±3dB
Impedance:	8 ohms nominal; 6 ohms minimum
Power Handling:	5 watts minimum; 60 watts maximum
Sensitivity:	90dB (2.83V/1 meter)
Grille Material:	Perforated aluminum
Dimensions (Dia x D):	6 <sup>7</sup> / <sub>8</sub> " x 3½" (175mm x 89mm)
Cutout Diameter:	5 <sup>7</sup> / <sub>8</sub> " (149mm)
Shipping Weight:	6 lbs (2.8kg) per pair

### 421MR

Tweeter:	¾" (19mm) silk dome
Woofers:	4½" (114mm) Black polypropylene cone with a rubber surround
Frequency Response:	70Hz – 20kHz ±3dB
Impedance:	8 ohms nominal; 6 ohms minimum
Power Handling:	5 watts minimum; 50 watts maximum
Sensitivity:	89dB (2.83V/1 meter)
Grille Material:	Perforated aluminum
Dimensions (Dia x D):	6 <sup>7</sup> / <sub>8</sub> " x 3½" (175mm x 89mm)
Cutout Diameter:	5 <sup>7</sup> / <sub>8</sub> " (149mm)
Shipping Weight:	6 lbs (2.8kg) per pair

### 421SSMR

Tweeter:	Two ¾" (19mm) silk domes
Woofers:	4½" (114mm) Black polypropylene cone with a rubber surround, dual voice coil
Frequency Response:	70Hz – 20kHz ±3dB
Impedance:	8 ohms nominal; 6 ohms minimum
Power Handling:	5 watts minimum; 50 watts maximum
Sensitivity:	89dB (2.83V/1 meter)
Grille Material:	Perforated aluminum
Dimensions (Dia x D):	6 <sup>7</sup> / <sub>8</sub> " x 3½" (175mm x 89mm)
Cutout Diameter:	5 <sup>7</sup> / <sub>8</sub> " (149mm)
Shipping Weight:	6 lbs (2.8kg) per pair

## Technical Assistance and Service

If you have any questions about the operation or installation of this product, please call our Technical Assistance Department on any business day at (800) 582-0772 or (949) 492-7777; from 7 a.m. to 5 p.m., PST.

If your speakers should need repair or service, contact your Sonance Authorized Dealer for help, or use the following procedure:

1. Prior to calling, note the product's model number, serial number, purchase date, and the name and address of the dealer where you purchased the product.
2. Contact our Technical Assistance Department at the above number(s) and describe the problem the unit is experiencing. If applicable, they will issue a Return Authorization Number.

**IMPORTANT: YOU MUST HAVE PRIOR AUTHORIZATION TO RETURN YOUR SPEAKER TO SONANCE!**

3. If you're directed to return the unit to Sonance for repair, pack the unit in its original shipping carton. If needed, you can obtain replacement packaging from us for a small charge. Note: it is best if you place the box into an additional outer "overcarton" before shipment to minimize a chance of theft in shipment. Please include a copy of the original bill of sale inside the package.
4. Contact a package delivery company such as United Parcel Service or Federal Express to arrange prepaid (not collect) shipping. Do not use the U.S. Postal Service.

**IMPORTANT: Freight collect shipments will be refused.**

**5. Write the Return Authorization Number on the outside of the shipping carton.**

6. Ship the packaged unit to:

*Quality Assurance Department  
Sonance  
212 Avenida Fabricante  
San Clemente, CA 92672-7531*

## Limited Lifetime Warranty Coverage (U.S. Only)

*Sonance warrants to the original retail purchaser only that this Sonance product will be free from defects in materials and workmanship, provided the product was purchased from a Sonance Authorized Dealer.*

Defective products must be shipped, together with proof of purchase, prepaid insured to the Authorized Sonance Dealer from whom they were purchased, or to the Sonance factory at the address listed in this instruction manual. Freight collect shipments will be refused. It is preferable to ship this product in the original shipping container to lessen the chance of transit damage. In any case, the risk or loss or damage in transit is to be borne by the purchaser. If upon examination at the factory or Authorized Sonance Dealer it is determined that the unit was defective in materials or workmanship at any time during this warranty period, Sonance or the Authorized Sonance Dealer will, at its option, repair or replace this product at no additional charge, except as set forth below. If this model is no longer available and can not be repaired effectively, Sonance, at its sole option, may replace the unit with a current model of equal or greater value. In some cases where a new model is substituted, a modification to the mounting surface may be required. If mounting surface modification is required, Sonance assumes no responsibility or liability for such modification. All replaced parts and product become the property of Sonance. Products replaced or repaired under this warranty will be returned to the original retail purchaser, within a reasonable time, freight prepaid.

This Warranty does not include service or parts to repair damage caused by accident, disaster, misuse, abuse, negligence, inadequate packing or shipping procedures, commercial use, voltage inputs in excess of the rated maximum of the unit, or service, repair or modification of the product which has not been authorized or approved by Sonance. This Warranty also excludes normal cosmetic deterioration caused by environmental conditions. This Warranty will be void if the Serial Number on the product has been removed, tampered-with or defaced. This Warranty is in lieu of all other expressed warranties. If the product is defective in materials or workmanship as warranted above, the purchaser's sole remedy shall be repair or replacement as provided above. In no event will Sonance be liable for any incidental or consequential damages arising out of the use or inability to use the product, even if Sonance or an Authorized Sonance Dealer has been advised of the possibility of such damages, or for any claim by any other party.

Some states do not allow the exclusion or limitation of consequential damages, so the above limitation and exclusion may not apply. All implied warranties on the product are limited to the duration of this expressed Warranty. Some states do not allow limitation on the length of an implied warranty. If the original retail purchaser resides in such a state, this limitation does not apply.

## EXCLUSIONS AND LIMITATIONS

The warranty set forth above is in lieu of all other warranties, express or implied, of merchantability, fitness for a particular purpose, or otherwise. The warranty is limited to Sonance products registered herein and specifically excludes any damage to loudspeakers and other allied or associated equipment which may result for any reason from use with this product. Sonance shall, in no event, be liable for incidental or consequential damages arising from any breach of this warranty or otherwise. This warranty gives you specific legal rights, and you may have other rights which vary from state to state.

System Notes:





**SONANCE<sup>®</sup>**

©2006 Sonance. All rights reserved. Sonance, Sonance Merlot, RotoLock, Sonafill, MedialinQ and FastMount are registered trademarks of Dana Innovations.

Due to continuous product improvement, all features and specifications are subject to change without notice.

For the latest Sonance product specification information visit our website: [www.sonance.com](http://www.sonance.com)

SONANCE • 212 Avenida Fabricante • San Clemente, CA 92672-7531 USA

(800) 582-7777 or (949) 492-7777 • FAX: (949) 361-5151 • Technical Support: (800) 582-0772

**[www.sonance.com](http://www.sonance.com)**