

# **SNAPPER**

## **LEAF BLOWER OWNER'S MANUAL**

**SLB552PN & SLB862IC**

### **NOTICE**

**FAMILIARIZE YOURSELF WITH THE CAUTION INSTRUCTIONS BELOW BEFORE PROCEEDING TO READ THE INSTRUCTION MANUAL. IMPROPER OPERATION CAN CAUSE SERIOUS INJURY.**

## **CAUTION**

**DO NOT REMOVE IMPELLER COVER WHILE MACHINE IS RUNNING. SEVERE INJURY WILL RESULT.**

**PART NO. 091-0059**

## **CAUTION**

- (1) READ OPERATING INSTRUCTIONS THOROUGHLY BEFORE USING.**
- (2) DANGER: Rotating parts. Keep hands, feet, and clothing out of openings at all times and especially while machine is running.**
- (3) NEVER operate with the impeller housing cover removed.**
- (4) NEVER direct the discharge air stream towards any persons, children, or animals.**
- (5) Stop engine and disconnect spark plug wire before attempting to clean the intake screen or discharge chute.**
- (6) Do not use this machine for any purpose other than that for which intended.**

**PART NO. 091-0058**

**SNAPPER \* 1189 Old Schuylkill Road \* P.O. Box 111 \* Parker Ford, PA 19457-0111  
PHONE: (215) 495-7181 \*\*\* FAX: (215) 495-5951**

# LEAF BLOWER OWNER'S MANUAL

## Assembly Instructions

Your leaf blower has been carefully packed at the factory. Before proceeding with assembly, make sure all parts have been received and are in good condition. If there are shortages or damage, report it immediately to the company from whom you obtained the machine.

*(Note: In the following instructions, the item number refers to the number encircled for that part on the drawing, page 3.)*

1. Locate the two large rubber handle washers (item 6) and slide them onto the upper handle, one on each side.
2. Insert the upper handle into the lower square tube handle. Note that there are three holes in each side of the upper handle. These are height adjustment holes. Position the upper handle at a comfortable height for you (usually waist high). Move the upper handle up or down slightly to align the hole in the upper handle and lower handle. Locate the upper lifting handle (item 4) and with the hardware provided, bolt through the upper lifting handle, lower and upper handle. Tighten securely.
3. Attach the throttle control to the upper handle as per the drawing.
4. Place the front wheel (item 41) into the front wheel bracket (item 38). Insert the shoulder bolt (item 39) through the front wheel bracket and wheel and hold in place with the 3/8-16 Grip Co lock nut (item 42).

NOTE: The front wheel bracket (item 38) provides two different discharge height adjustments by turning the bracket over. The total discharge height adjustment is 1-1/4".

5. Service the engine as recommended by the manufacturer. Fill the fuel tank with lead-free or low-lead gasoline.
6. Familiarize yourself with the operating instructions before attempting to use your blower

## Operating Instructions

1. For maximum air speed, run the engine with throttle wide open in the "FAST" position.
2. To change air flow from side to front, simply pull diverter handle back to direct air flow to the side and push handle forward to direct air flow to the front.
3. Never direct the discharge air stream toward any observers, children, pets or fragile objects. Small stones, twigs, or grit can be thrown with sufficient force to cause injury or damage.
4. When running machine, **DO NOT PUT HANDS OR FEET INTO INLET OR OUTLET** because the rotating impeller can cause injury.
5. Never start engine or use blower without impeller cover mounted in place. Do not put any objects like sticks or fingers in holes of impeller cover.
6. Stop the engine and disconnect the spark plug wire before attempting to clean obstructions or blockage from the intake or discharge passages.
7. Stop the engine and allow it to cool for at least two minutes before refilling the gas tank or before lifting leaf blower.

## Maintenance Instructions

1. Follow engine owner's manual for engine maintenance and repair.
2. When not in use, your leaf blower should be stored out of reach of children. Be sure there are no gasoline fumes in the storage area. For long periods of storage (over winter), gasoline should be drained from the gas tank or add a gas stabilizer (i.e. Stabil). Always allow the engine to cool before storing.

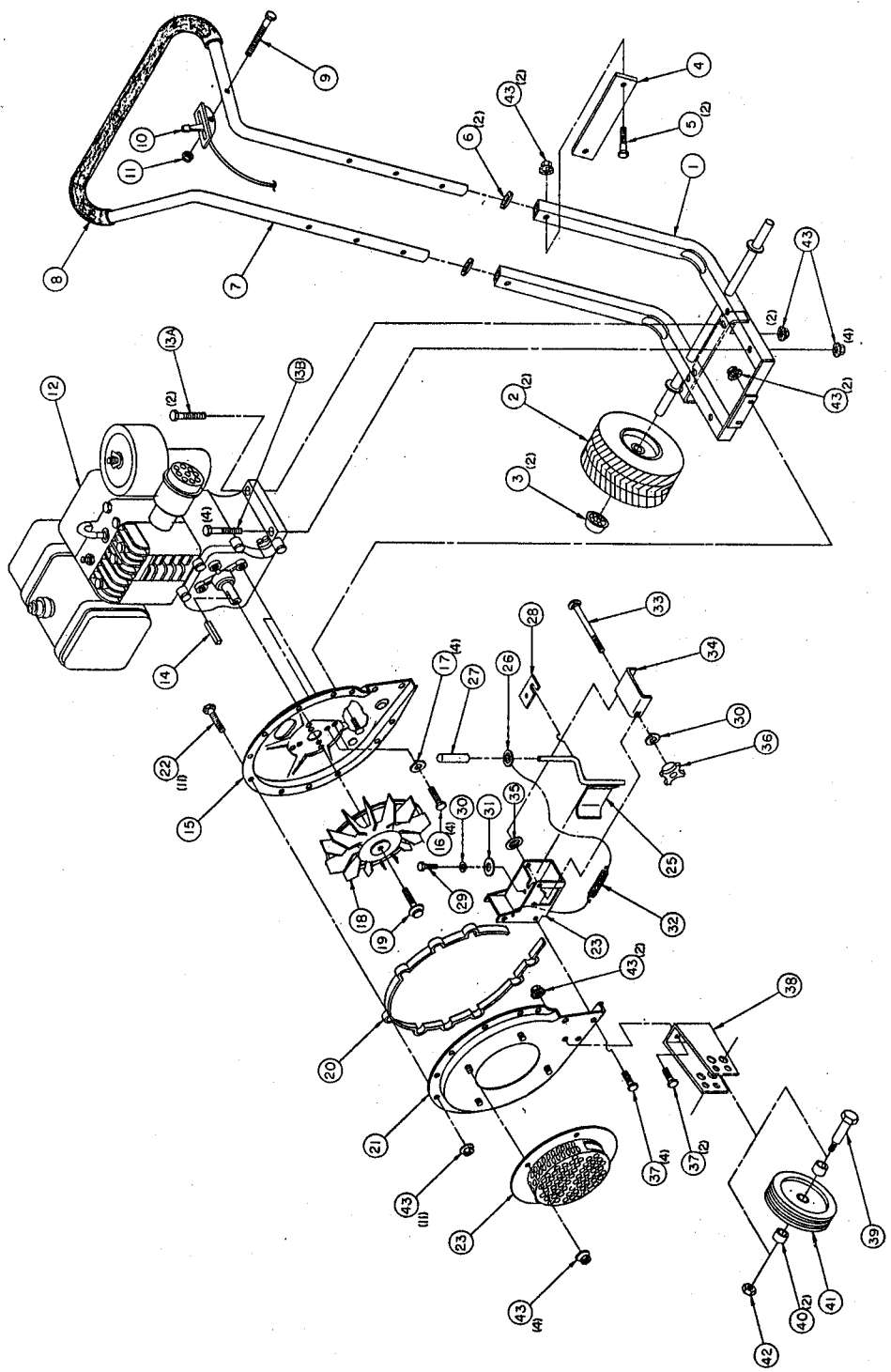
Part No.	LB552/LB552PN	None	JTS
Part No.	LB662/LB662C	None	JTS
Part No.	LEAF BLOWER ASSEMBLY		
Part No.	5-19-92	705-0000	

## LEAF BLOWER PARTS LIST

<u>Item No.</u>	<u>PART NO. SLB552PN</u>	<u>PART NO. SLB862IC</u>	<u>Quantity</u>	<u>Description</u>
1	705-0088	705-0092	1	Lower Handle Bar Assembly
2	703-0108	703-0108	2	Wheel 4.10 x 3.50 x 4
3	090-0457	090-0457	2	Push Nut Cap
4	705-0028-2	705-0028-2	1	Upper Lifting Handle
5	090-0091	090-0091	2	5/16-18 x 1-3/4" HHCS Pltd
6	705-0044	705-0044	2	Washer Handle Bar
7	705-0034	705-0034	1	Upper Handlebar Assembly
8	705-0002	705-0002	1	Grip, Handlebar
9	090-0057	090-0057	1	1/4-20 x 1-1/2" HHCS Pltd
10	703-0422	703-0422	1	Throttle Control
11	090-0031	090-0031	1	1/4-20 Flex Locknut Pltd
12	703-0415		1	5 HP Engine
		030-0172	1	8HP IC Engine
13A	090-0090		2	5/16-18 x 1-1/2" HHCS Pltd
13B		090-0419	4	5/16-18 x 2-3/4" HHCS Pltd
14	703-0424	703-0424	1	1/4" x 1/4" x 2" Lg. Shaft Key
15	705-0095-RD	705-0095-RD	1	Engine Housing
16	090-0408	090-0408	4	5/16-24 x 3/4" HHCS Pltd
17	090-0392	090-0392	4	5/16" Split Lockwasher Pltd
18	705-0084	705-0084	1	Impeller
19	090-0021	090-0021	1	3/8-24 x 1-1/4" HHCS Pltd
20		705-0097-RD	1	Housing Spacer
21	705-0093-RD	705-0093-RD	1	Front Housing
22	090-0067		11	5/16-18 x 5/8" HHCS Pltd
		090-0090	11	5/16-18 x 1-1/2" HHCS Pltd
23	703-0021-A	703-0021-A	1	Impeller Cover
24	705-0100-RD	705-0104-RD	1	Chute Weld Assembly
25	705-0108	705-0110	1	Diverter Weld Assembly
26	090-0225	090-0225	1	3/8" Internal Lockwasher Pltd.
27	701-0185	701-0185	1	Vinyl Grip, Diverter Handle
28	705-0113	705-0113	1	Diverter Clip
29	090-0052	090-0052	1	1/4-20 x 1/2" HHCS Pltd
30	090-0378	090-0378	2	1/4" Split Lockwasher Pltd
31	090-0232	090-0232	1	1/4" Flat Washer Pltd
32	701-0059	701-0059	1	Spring, Diverter
33	090-0480		1	1/4-20 x 5" Lg. Carriage Bolt
		090-0481	1	1/4-20 x 6" Lg. Carriage Bolt
34	705-0098-RD	705-0099-RD	1	Deflector
35	090-0223	090-0223	1	1/4" Internal Lockwasher Pltd
36	705-0049	705-0049	1	Adjustment Knob
37	090-0067	090-0067	6	5/16-18 x 5/8" HHCS Pltd
38	705-0014	705-0014	1	Front Wheel Bracket
39	705-0056-2	705-0056-1	1	Hex Head Shoulder Bolt
40	705-0043		2	Spacer, Wheel
41	703-0025	701-0052	1	Front Wheel
42	090-0042	090-0042	1	3/8-16 Gripco Locknut
43	090-0418	090-0418	25	5/16-18 Whiz Locknut Pltd
44	090-0228	090-0228	1	3/8" Med. Split Lockwasher

When ordering parts always specify the part number, not the item number.