

**STAMINA**<sup>®</sup>  
**UX2** AIR BIKE

AIR RESISTANCE  
**Upright Bike**

**Owner's Manual**

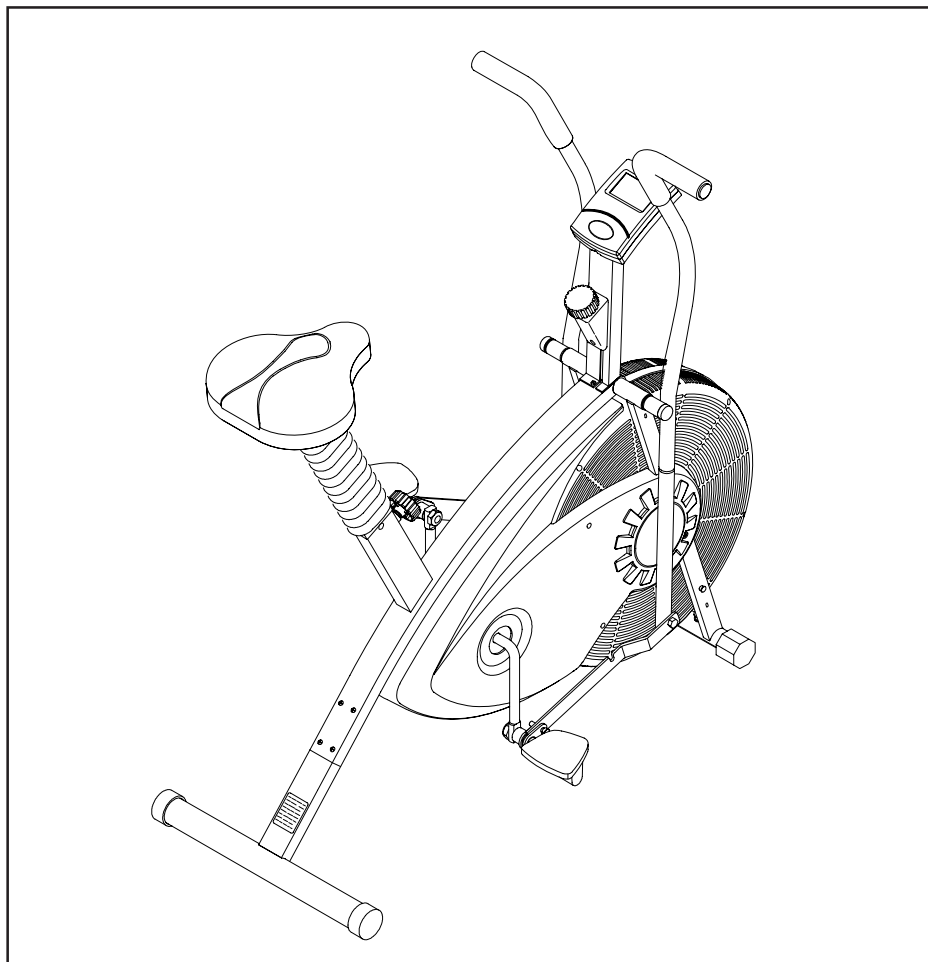

**⚠ WARNING ⚠**

Exercise can present a health risk. Consult a physician before beginning any exercise program with this equipment. If you feel faint or dizzy, immediately discontinue use of this equipment. Serious bodily injury can occur if this equipment is not assembled and used correctly. Serious bodily injury can also occur if all instructions are not followed. Keep others and pets away from equipment when in use. Always make sure all bolts and nuts are tightened prior to each use. Follow all safety instructions in this manual.

When calling for parts or service, please specify the following number.

**15-0960**

**STAMINA PRODUCTS**  
MADE IN CHINA

Product May Vary Slightly  
From Pictured.

**CAUTION:**  
Weight on this product should not exceed 250 lbs.

**This Product is Produced Exclusively by**



2040 N. Alliance, Springfield, MO 65803  
Customer Service Number  
1 (800) 375-7520  
[www.staminaproducts.com](http://www.staminaproducts.com)

## TABLE OF CONTENTS

	Page		Page
Safety Precautions	2	Adjustment Instructions	15
Before You Begin	4	Conditioning Guidelines	17
Hardware Illustrations	5	Warm-up and Cool-Down	18
Assembly Instructions	6	Warranty	19
Set Up Instructions	10	Product Parts Drawing	20
Operational Instructions	11	Parts List	21
Storage	14	Fax/Mail Ordering Form	23
Maintenance	14		

### SAFETY PRECAUTIONS

**WARNING:** To reduce the risk of serious injury, read the following Safety Precautions before using the **UX2 AIR BIKE**.

1. Read all warnings posted on the **UX2 AIR BIKE**.
2. Read this owner's/user's manual and follow it carefully before using the **UX2 AIR BIKE**.
3. We recommend that two people be available for assembly of this product.
4. To avoid a pinch point, make sure that the spacer is properly assembled between the CRANK and LINKAGE CONNECTOR on both sides of the **UX2 AIR BIKE**. See assembly STEP 11.
5. Keep children away from the **UX2 AIR BIKE**. Do not allow children to use or play on the **UX2 AIR BIKE**. Keep children and pets away from the **UX2 AIR BIKE** when it is in use.
6. It is recommended that you place this exercise equipment on an equipment mat.
7. Set up and operate the **UX2 AIR BIKE** on a solid level surface. Do not position the **UX2 AIR BIKE** on loose rugs or uneven surfaces.
8. Adjust the LEVELING CAPS on the FRONT STABILIZER so that the **UX2 AIR BIKE** sets on the floor without rocking.
9. Inspect the **UX2 AIR BIKE** for worn or loose components prior to use.
10. Always check to see that the SEAT POST is securely fastened before using the **UX2 AIR BIKE**.
11. Tighten/replace any loose or worn components prior to using the **UX2 AIR BIKE**.
12. Consult a physician prior to commencing an exercise program. If, at any time during exercise, you feel faint, dizzy, or experience pain, stop and consult your physician.
13. Follow your physician's recommendations in developing your own personal fitness program.
14. Always choose the workout which best fits your physical strength and flexibility level. Know your limits and train within them. Always use common sense when exercising.
15. Do not wear loose or dangling clothing while using the **UX2 AIR BIKE**.
16. Never exercise in bare feet or socks; always wear correct footwear, such as running, walking, or crosstraining shoes. Be sure that they fit well, provide foot support and feature non-skid rubber soles.
17. Care should be taken in mounting or dismounting the **UX2 AIR BIKE**.
18. The **UX2 AIR BIKE** should not be used by persons weighing over 250 pounds.
19. Do not ride the **UX2 AIR BIKE** standing up.
20. Do not place your head, hands, or legs between the HANDLEBARS.
21. Each user should adjust the seat per instructions on page 12.
22. The **UX2 AIR BIKE** should be used by only one person at a time.
23. The **UX2 AIR BIKE** is for consumer use only. It is not for use in public or semipublic facilities.

**WARNING:** Before starting any exercise or conditioning program you should consult with your personal physician to see if you require a complete physical exam. This is especially important if you are over the age of 35, have never exercised before, are pregnant, or suffer from any illness. **READ AND FOLLOW THE SAFETY PRECAUTIONS. FAILURE TO FOLLOW THESE INSTRUCTIONS CAN RESULT IN SERIOUS BODILY INJURY.**

# CALL US FIRST



**Customer Service Number**

**1(800) 375-7520**

---

**THANK YOU FOR PURCHASING THE  
STAMINA® UX2 AIR BIKE**

To help you get started, we have pre-assembled most of your UX2 AIR BIKE at the factory with the exception of those few parts left unassembled for shipping purposes. Simply follow the few assembly instructions set forth in this manual. With regular workouts you will be getting your body into shape and on your way to achieving a happier and healthier lifestyle.

Should you have any questions,  
please call our Customer Service Department toll-free number,  
**1 (800) 375-7520**

**Monday - Thursday, 7:30 A.M. - 5:00 P.M. Central Time.**  
**Friday, 8:00 A.M. - 3:00 P.M., Central Time.**



**TELEPHONE**  
CUSTOMER SERVICE  
Tel: 1 (800) 375-7520



**FAX**  
CUSTOMER SERVICE  
Fax: (417) 889-8064



**ONLINE**  
CUSTOMER SERVICE  
[parts@staminaproducts.com](mailto:parts@staminaproducts.com)  
[cust-srvc@staminaproducts.com](mailto:cust-srvc@staminaproducts.com)  
[www.staminaproducts.com](http://www.staminaproducts.com)



**MAIL**  
STAMINA PRODUCTS, INC.  
ATTN: Customer Service  
P.O. Box 1071  
Springfield, MO. 65801-1071

## BEFORE YOU BEGIN

Thank you for choosing the **UX2 AIR BIKE**. We take great pride in producing this quality product and hope it will provide many hours of quality exercise to make you feel better, look better and enjoy life to its fullest.

Yes, it's a proven fact that a regular exercise program can improve your physical and mental health. Too often, our busy lifestyles limit our time and opportunity to exercise. The **UX2 AIR BIKE** provides a convenient and simple method to begin your assault on getting your body in shape and achieving a happier and healthier lifestyle.

Before reading further, please review the drawing below and familiarize yourself with the parts that are labeled.

Read this manual carefully before using the **UX2 AIR BIKE**.



Although Stamina constructs its products with the finest materials and uses the highest standards of manufacturing and quality control, there can sometimes be missing parts or incorrectly sized parts. If you have any questions or problems with the parts included with your **UX2 AIR BIKE**, please do not return the product. Contact us **FIRST!**

If a part is missing or defective, please call us toll free at 1-800-375-7520 (in the U.S.). Our Customer Service Staff is available to assist you from 7:30 A.M. to 5:00 P.M. (Central Time) Monday through Thursday and 8:00 A.M. to 3:00 P.M. (Central Time) on Friday.

If you would like to contact us on-line, go to our website at [www.staminaproducts.com](http://www.staminaproducts.com) and access the Customer Service section.

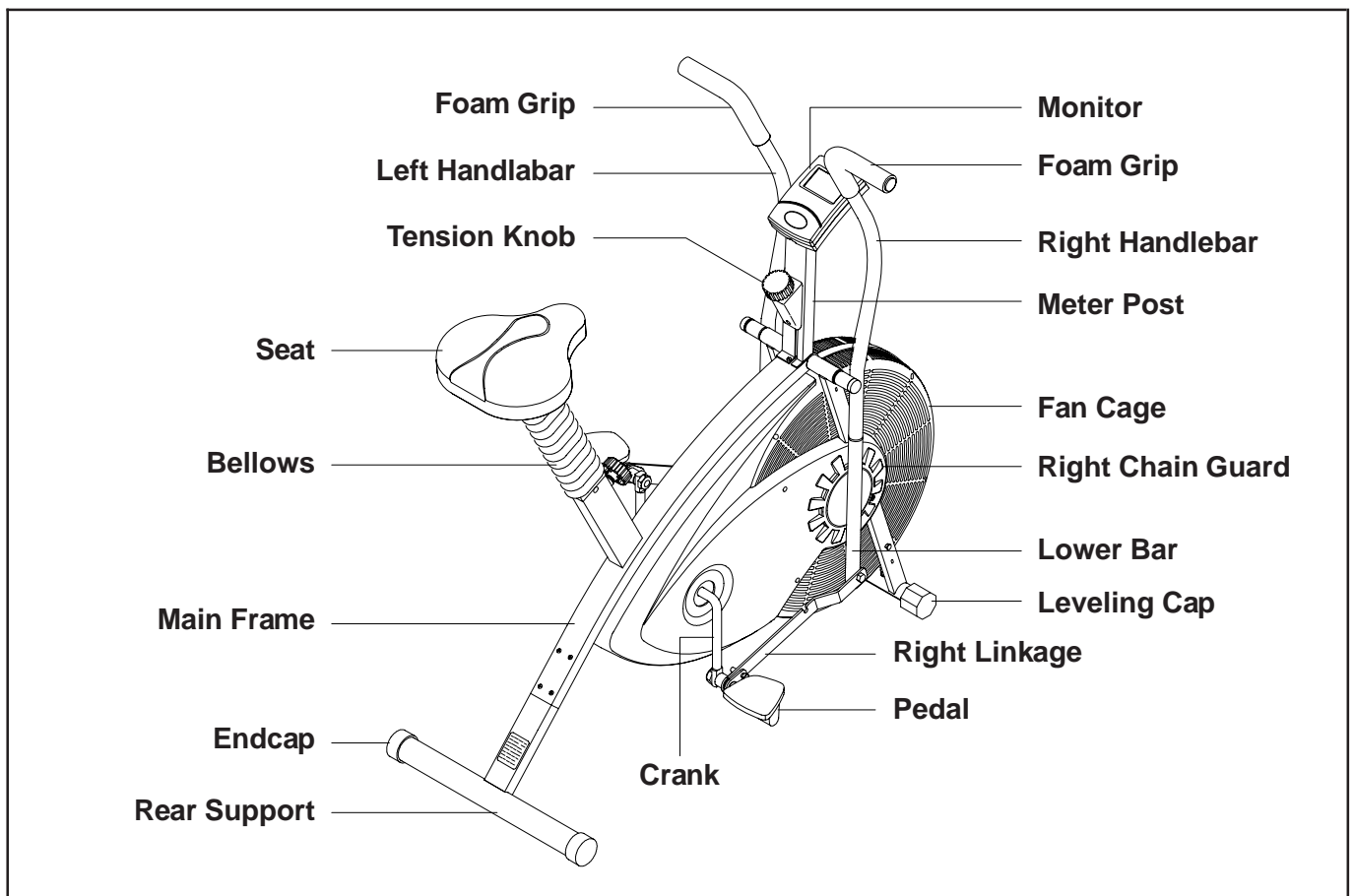
Be sure to have the name and model number of the product available when you contact us.

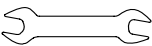

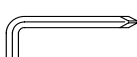
- THE FOLLOWING TOOLS ARE INCLUDED FOR ASSEMBLY :**
-  Wrench
  -  Multi-opening Wrench
  -  Allen Wrench (6mm)

# HARDWARE IDENTIFICATION CHART



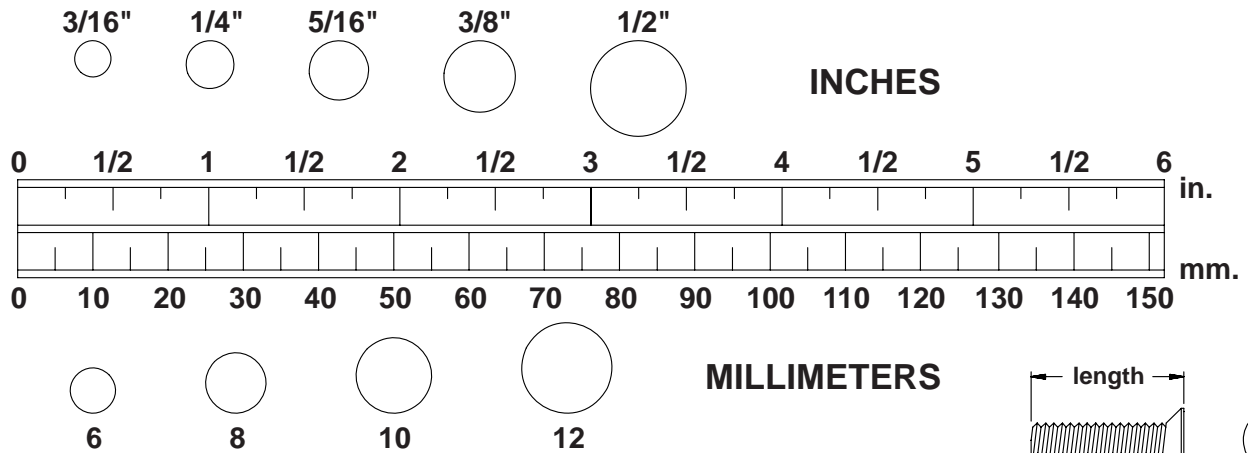

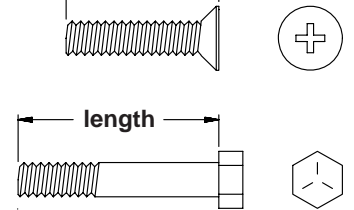

This chart is provided to help identify the hardware used in the assembly process. Place the washers, the end of the bolts, or screws on the circles to check for the correct diameter. Use the small scale to check the length of the bolts and screws.

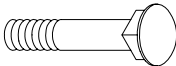
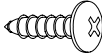
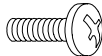
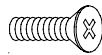
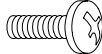

**NOTICE:** The length of all bolts and screws except those with flat heads is measured from below the head to the end of the bolt or screw. Flat head bolts and screws are measured from the top of the head to the end of the bolt or screw.

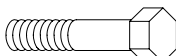

After unpacking the unit, open the hardware bag and make sure that you have all the following items. Some hardware may be already attached to the part.

	Part No. and Description	Qty
	51 Carriage Bolt (M8 x 1.25 x 38mm)	2
	53 Screw, Round Head (M5 x 15mm)	1
	57 Screw, Round Head (M5 x 0.8 x 12mm)	4
	58 Screw, Flat Head (M5 x 0.8 x 15mm)	1
	59 Bolt, Round Head (M6 x 1 x 12mm)	4
	35 Thin Nut (1/2"-20)	2
	61 Bolt, Hex Head (M8 x 1.25 x 45mm)	2
	62 Nylock Nut (M8 x 1.25)	7
	64 Acorn Nut (M8 x 1.25)	2
	70 Arc Washer (M6)	4
	71 Arc Washer (M8)	4
	38 Bushing Washer (ø16.3 x ø25 x 0.5t)	2
	39 Large Washer (M8)	2
	67 Washer (M8 x ø16mm x 1.5mm)	3
	68 Washer (M8 x ø22mm x 1.5mm)	2

---

## ASSEMBLY INSTRUCTIONS

Place all parts from the box in a cleared area and position them on the floor in front of you. Remove all packing materials from your area and place them back into the box. Do not dispose of the packing materials until assembly is completed. Read each step carefully before beginning. If you are missing a part please call our toll-free number for assistance **1 (800) 375-7520** or e-mail us at:

**parts@staminaproducts.com**

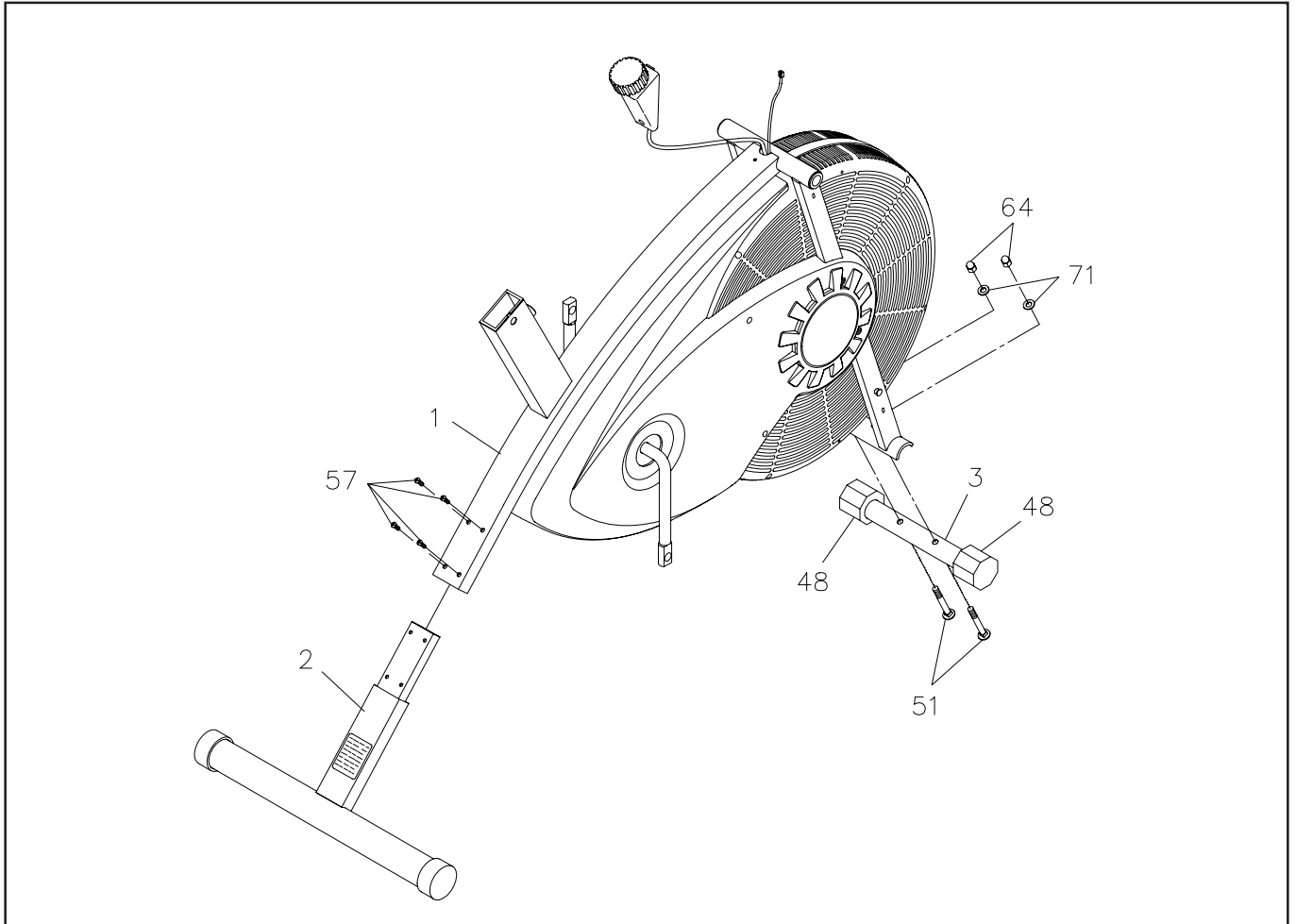

### STEP 1

Insert **REAR SUPPORT(2)** into the **MAIN FRAME(1)** and fasten with **ROUND HEAD SCREWS (M5x0.8x12mm)(57)**.

### STEP 2

Attach **FRONT STABILIZER(3)** onto the **MAIN FRAME(1)** with **CARRIAGE BOLTS(M8x1.25x38mm)(51)**, **ARC WASHERS(M8)(71)**, and **ACORN NUTS(M8x1.25)(64)**.

### STEP 3

Turn the **LEVELING CAPS(48)** on the **FRONT STABILIZER(3)** as needed until bike is steady and not rocking.

## ASSEMBLY INSTRUCTIONS

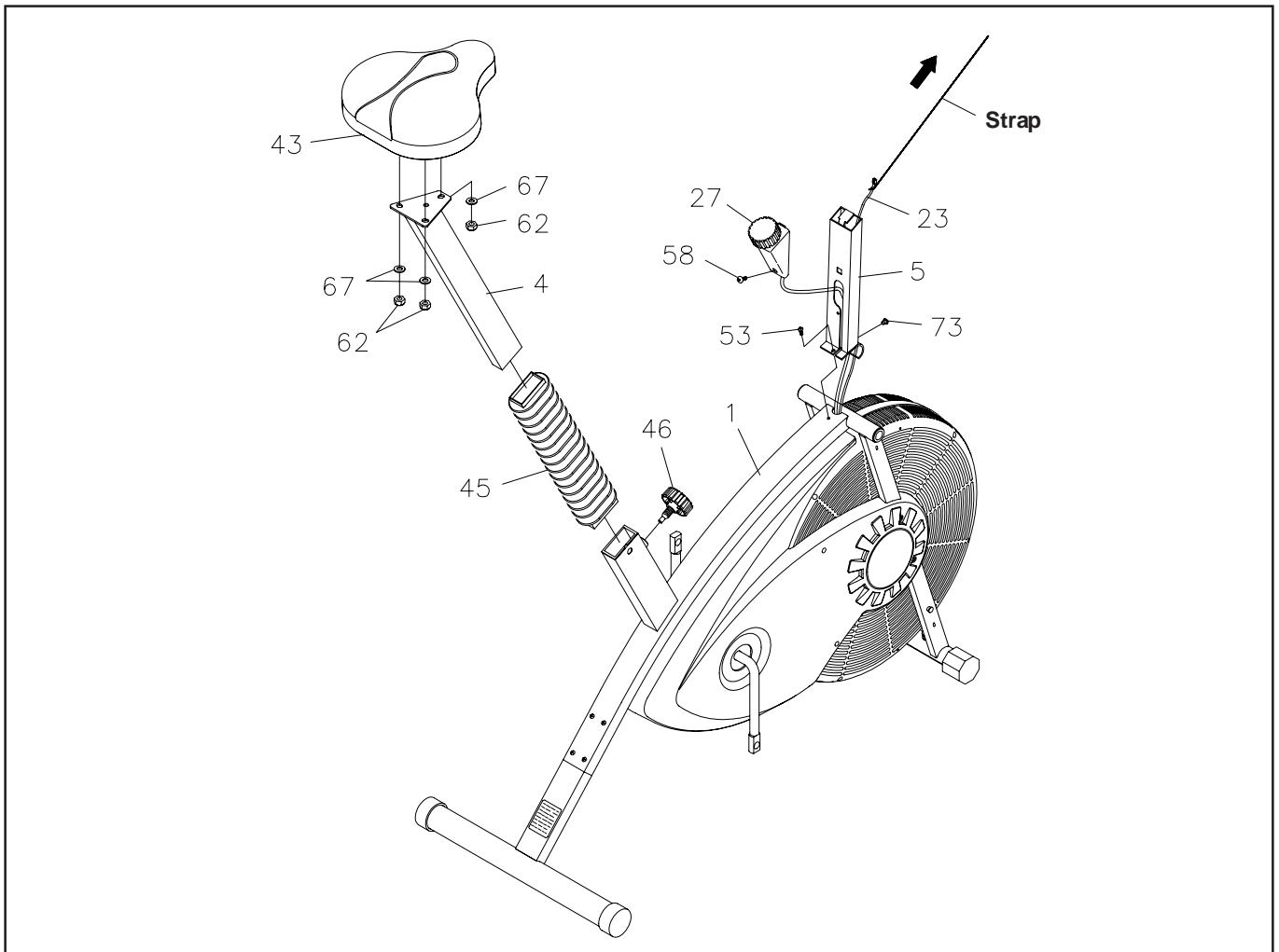

### STEP 4

Attach the **SEAT(43)** to the **SEAT POST(4)** with **NYLOCK NUTS(M8x1.25)(62)** and **WASHERS(M8)(67)**. Slide **BELLOWS(45)** over the **SEAT POST(4)**. Insert the **SEAT POST(4)** into the **MAIN FRAME(1)** and lock in position with **LOCKING KNOB(46)**.

### STEP 5

Slide the Cable of the **TENSION KNOB(27)** into the slot on the **MONITOR POST(5)**. Hook the top end of the **TENSION KNOB(27)** into the square hole on the **MONITOR POST(5)** and secure with **FLAT HEAD SCREW (M5x0.8x15mm)(58)**.

### STEP 6

**NOTE:** There is a strap attached inside of the **MONITOR POST(5)**. This strap is to assist in pulling the **SPEED PICKUP WIRE(23)** through the **MONITOR POST(5)**.

Tie the strap to the plug end of the **SPEED PICKUP WIRE(23)**. Pull the strap from the top of the **MONITOR POST(5)** to pull the **SPEED PICKUP WIRE(23)** through the **MONITOR POST(5)** as shown in the above illustration. The **SPEED PICKUP WIRE(23)** must extend out the top of the **MONITOR POST(5)**.

Attach the **MONITOR POST(5)** onto the **MAIN FRAME(1)** by hooking the front end of the Bracket on the bottom of the **MONITOR POST(5)** onto the round tube on the **MAIN FRAME(1)**, then secure with the **ROUND HEAD SCREW(M5x0.8x6mm)(73)** at front of the Bracket. Secure the back end of the Bracket of the **MONITOR POST(5)** with the **ROUND HEAD SCREW(M5x15mm)(53)**. Remove the strap from the **SPEED PICKUP WIRE(23)**.



## ASSEMBLY INSTRUCTIONS

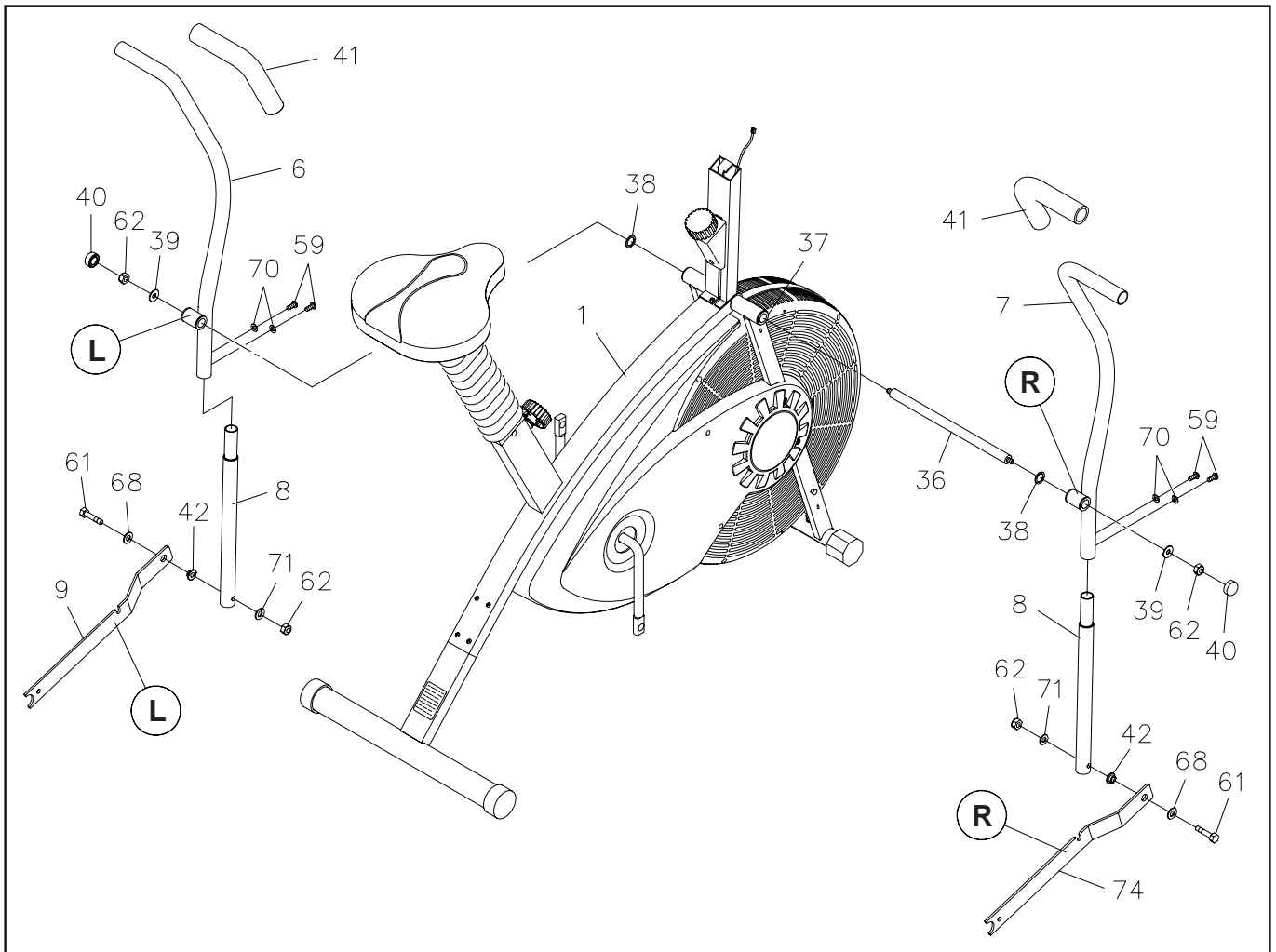

### STEP 7

There is a "R" decal on the **RIGHT HANDLEBAR(7)** and **RIGHT LINKAGE(74)**. Refer to above illustration. Press a **LINKAGE BUSHING(42)** into the **RIGHT LINKAGE(74)**. Attach the **RIGHT LINKAGE(74)** onto the bottom end of **LOWER BAR(8)** with **HEX HEAD BOLT(M8x1,25x45mm)(61)**, **WASHER(M8xø22mmx1.5mm)(68)**, **ARC WASHER(M8)(71)**, and **NYLOCK NUT(M8x1.25)(62)**.

### STEP 8

Attach the right **LOWER BAR ASSEMBLY(8)** to the **RIGHT HANDLEBAR(7)** with **ROUND HEAD BOLTS(M6x1x12mm)(59)** and **ARC WASHERS(M6)(70)**. Repeat **STEP 7** and **STEP 8** to assemble the **LEFT HANDLEBAR(6)**.

### STEP 9

Slide the **AXLE(36)** through **BUSHINGS(37)** into the **MAIN FRAME(1)**. Slide the two **BUSHING WASHERS(38)** onto both sides of the **AXLE(36)**. Slide the **LEFT** and **RIGHT HANDLEBARS(6, 7)**, with the **GRIPS** facing outside, onto **AXLE(36)** and fasten with **LARGE WASHERS(M8)(39)** and **NYLOCK NUTS(M8x1.25)(62)**. Place a **NUT CAP(40)** onto the **NYLOCK NUT(M8x1.25)(62)** on both sides.

### STEP 10

Slide the two **FOAM GRIPS(41)** onto the **LEFT** and **RIGHT HANDLEBARS(6, 7)**.

**NOTE:** Lubricate the **LEFT** and **RIGHT HANDLEBARS(6, 7)** with a small amount of liquid soap for easier installation of the **FOAM GRIPS(41)**.



## ASSEMBLY INSTRUCTIONS

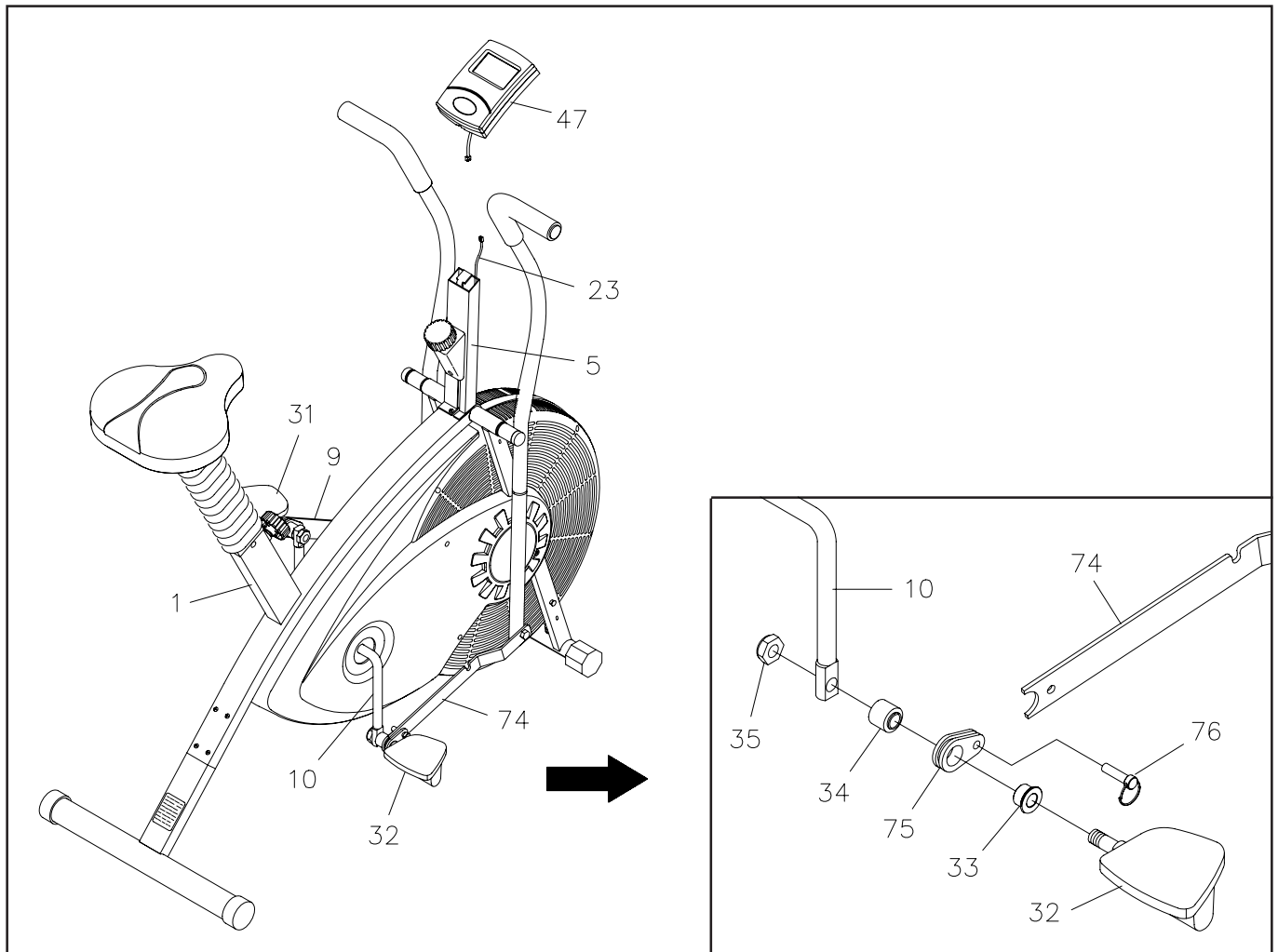

**IMPORTANT** STUDY THE ABOVE ILLUSTRATION AND READ ALL OF STEP 11 "a" through "g" BEFORE ATTACHING PEDALS AND CONNECTING LINKAGES.

### STEP 11

**NOTE:** The **RIGHT PEDAL(32)** has **R** marked on the bottom side of the pedal. The **LEFT PEDAL(31)** has **L** marked on the bottom side of the pedal. Both **PEDALS(31, 32)** have **RIGHTHAND THREADS**. Tighten both **PEDALS(31, 32)** by turning clockwise.

- Push **PEDAL BUSHINGS(33)**, with **SHOULDER** facing outside, into **LINKAGE CONNECTORS(75)**.
- Insert **PEDAL SHAFTS** of **PEDALS(31, 32)** through **SHOULDER** side of **PEDAL BUSHINGS(33)**.
- Slide **SPACERS(34)** onto **PEDAL SHAFTS**.  
**WARNING: SPACERS(34)** must be between **PEDAL BUSHINGS(33)** and **CRANK(10)** so that there will be enough clearance between **LINKAGES(9, 74)** and **CRANK(10)**.
- Thread **PEDAL SHAFTS** of **PEDALS(31, 32)** into **CRANK(10)** and tighten.
- Hold **PEDAL SHAFTS** with wrench and thread **THIN NUTS(1/2"-20)(35)** onto **PEDAL SHAFTS**.
- Tighten **PEDAL SHAFTS** and **THIN NUTS(1/2"-20)(35)** until **THIN NUTS(1/2"-20)(35)** are tight against **CRANK(10)**.
- Connect the **LINKAGES(9, 74)** to the **LINKAGE CONNECTORS(75)** with the **LOCKING PINS(76)**.

### STEP 12

Install two "AA" batteries into the **MONITOR(47)**, two batteries included. Plug the **SPEED PICKUP WIRE(23)** into the **MONITOR(47)**. Slide the **MONITOR(47)** onto the **BRACKET** on the **MAIN FRAME(1)**. See page 11 for detailed battery installation instructions.

---

## SET UP INSTRUCTIONS

Place the **UX2 AIR BIKE** in the area where it will be used. It is recommended that the **UX2 AIR BIKE** be placed on an equipment mat. The **UX2 AIR BIKE** is approximately 42 1/2" long x 22 1/4" wide x 45 1/4" tall. (These dimensions may vary up to one inch.) An area 4 feet wide x 6 feet long is required for safe operation of the **UX2 AIR BIKE**. Make sure that adequate space is available for access to and passage around the **UX2 AIR BIKE**.

**LEVELING:** Use the **LEVELING CAPS(48)** on the **FRONT STABILIZER(3)** to level the **UX2 AIR BIKE** so there is no movement or rocking during your workout. Remove and reposition the **LEVELING CAPS(48)** so the flat side of both caps are in contact with the floor.

**MOVING:** To move the **UX2 AIR BIKE**, it is recommended that two people move the bike together.

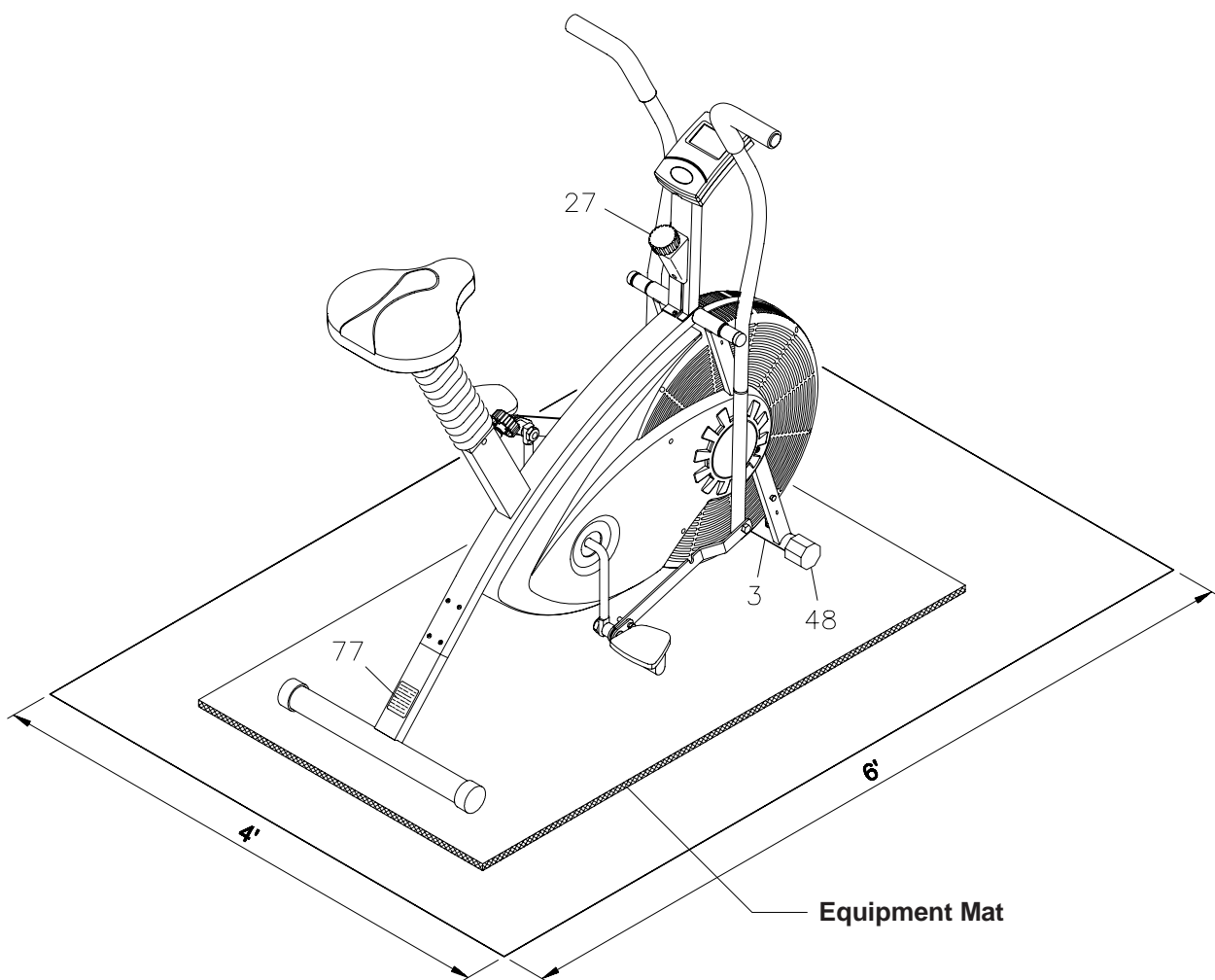

### FUNCTION INSPECTION:

Visually inspect the **UX2 AIR BIKE** to verify that assembly is as shown in the above illustration. Check the function of the **UX2 AIR BIKE**. Turn the crank slowly through one complete revolution to verify that the drive chain functions properly. Adjust the **TENSION KNOB(27)** and verify that it functions properly.

**CAUTION:** Locate and read the **WARNING LABEL(77)** on the **UX2 AIR BIKE**. Make sure that all users read the **WARNING LABEL(77)**.

---

## OPERATIONAL INSTRUCTIONS

### USING THE MONITOR

**POWER ON :** Pedal movement or push the **MODE** button.

**POWER OFF :** Automatic shut off after four minutes of inactivity.

#### MODE BUTTON:

Press to select display functions, include **SCAN, TIME, SPEED, DISTANCE,** and **CALORIES.**

Press and hold for three seconds to reset all functions to zero.

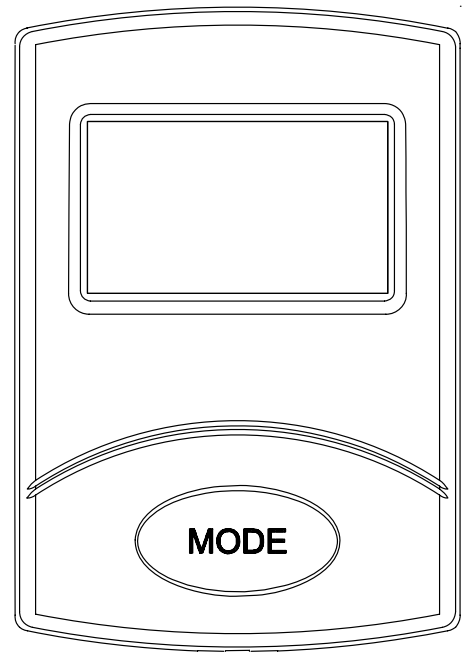

#### FUNCTIONS:

**SCAN:** Automatically scans each function of **TIME, SPEED, DISTANCE,** and **CALORIES** in sequence with change every four seconds. Press and release the **MODE** button until "**SCAN**" appears on the display.

**TIME:** Displays the time from one second up to 99:59 minutes.

**SPEED:** Displays the current speed from zero to 999.9 miles per hour.

**DISTANCE:** Displays the distance from zero to 99.99 miles.

**CALORIES:** Displays the calorie consumption from zero to 999.9 Kcal.  
The calorie readout is an estimate for an average user. It should be used only as a comparison between workouts on this unit.

**NOTE:** The monitor will shut off automatically after four minutes of inactivity. All function values will be kept. Push the **MODE** button and hold it down for three seconds to reset all functions to zero.

#### HOW TO INSTALL AND REPLACE BATTERIES:

1. Open the Battery Door on the back of the monitor.
2. The monitor operates with two AA batteries, two batteries included. Refer to the illustration to install or replace the batteries.

#### NOTE:

1. Do not mix a new battery with an old battery.
2. Use the same type of battery. Do not mix an alkaline battery with another type of battery.
3. Rechargeable batteries are not recommended.

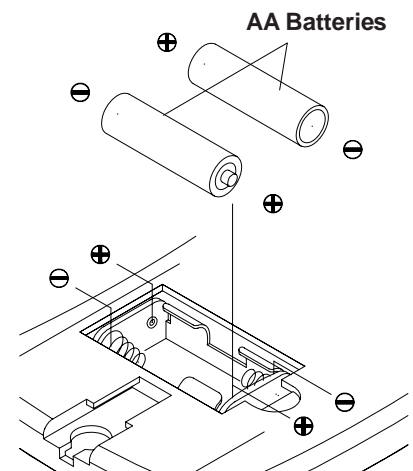

---

## OPERATIONAL INSTRUCTIONS

### SEAT HEIGHT ADJUSTMENT

Proper seat height is important for efficient exercise. To determine proper seat height, sit on the bike and center the ball of your foot on the pedal in the down position. Your leg should be slightly bent and relaxed as shown.

If your leg is too straight or your foot cannot touch the pedal, you will need to lower the seat. If your leg is bent too much you will need to raise the seat. Remove the **LOCKING KNOB(46)**. Lower or raise the **SEAT(43)** to the desired height and secure with the **LOCKING KNOB(46)**.

**CAUTION:** The **LOCKING KNOB(46)** must be inserted into one of the holes in the **SEAT POST(4)**.

**NOTE:** The **LOCKING KNOB(46)** should be screwed in tight to make the **SEAT POST(4)** fit securely in the **MAIN FRAME(1)**.

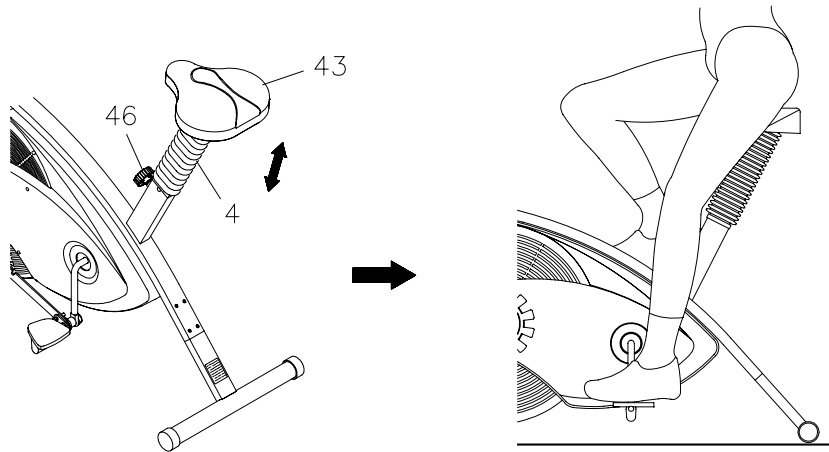

### LOAD ADJUSTMENT

To increase the load, turn the **TENSION KNOB(27)** clockwise. To decrease the load, turn the **TENSION KNOB(27)** counterclockwise.

**NOTE:** The load will increase as you pedal faster.

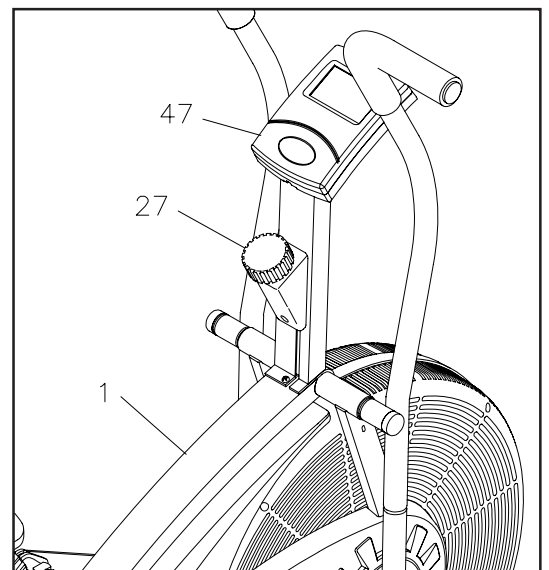

---

## OPERATIONAL INSTRUCTIONS

### Exercise Workout

The secret to aerobic training is achieving a selected heart rate and maintaining it. The **UX2 AIR BIKE**, with its air resistance system allows the user to easily attain the desired pulse rate.

Since no two people or life styles are alike, the **UX2 AIR BIKE** has been designed to allow the user to isolate portions of the body that may need greater emphasis in training.

These exercises provide cardiovascular conditioning, muscle toning and joint flexing with the ability to exercise both the upper and lower body simultaneously or independently. Increase the workout intensity by increasing the speed of the leg and/or arm movements.

**Full Body Workout:** Sitting comfortably erect, use the handlebars to either push or pull while simultaneously pedaling. Alternate the effort to your arms or legs to intensify or reduce the work of the upper or lower body. The handlebars may be gripped from underneath (palm up) to change the muscle groups used in the arms.

**Lower Body Workout:** Switch to the Stationary Handlebar position shown below. As an alternative, you may simply release the handlebars and place your hands on your hips or thighs as you pedal. This concentrates the exercise on the lower body.

**Upper Body Workout:** Stand with feet on the Rear Stabilizer, lean over the seat and activate the fan using the handlebars. This exercise is most effective when the muscles of the torso are used in a twisting motion.

### Advantages:

1. For the Upper Body:

**Handlebar Push:** Provides cardiovascular conditioning, triceps, upper back, and shoulder muscle training.

**Handlebar Pull:** Provides cardiovascular conditioning, biceps, shoulder, and chest muscle training.

2. For the Lower Body:

**Pedaling:** Provides cardiovascular conditioning, thigh and calf muscle toning, and hip, knee, and ankle flexion.

### Stationary Handlebar

The Dual Action Handlebars can be switched into the stationary position. Please follow the following process:

1. Remove the **LOCKING PIN(76)** from the **LINKAGE CONNECTOR(75)**.
2. Swing the **RIGHT LINKAGE(74)** forward to the front of the BIKE and hook the **RIGHT LINKAGE(74)** onto the **HOOK LUG** on the frame.
3. Store the **LOCKING PIN(76)** in the **LINKAGE CONNECTOR (75)**.
4. Do the same for other side.

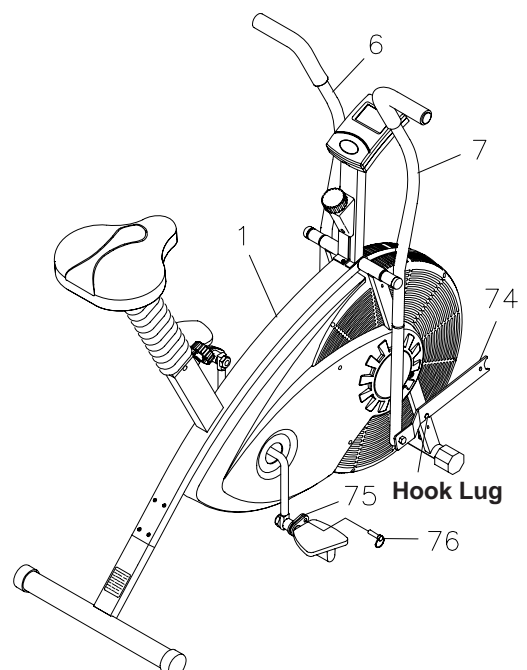

## STORAGE

1. To store the **UX2 AIR BIKE** simply keep it in a clean dry place.
2. The **UX2 AIR BIKE** is 42 1/2" long x 22 1/4" wide x 45 1/4" tall.
3. The **UX2 AIR BIKE** must be lifted for movement. Two people may be required.
4. To avoid damage to the electronics, remove the batteries before storing the **UX2 AIR BIKE** for one year or more.

## MAINTENANCE

The safety and integrity designed into the **UX2 AIR BIKE** can only be maintained when the **UX2 AIR BIKE** is regularly examined for damage and wear. Special attention should be given to the following:

1. Verify that the Thin Nuts(35) are properly tightened to prevent the pedals from coming loose.
2. Verify that the Warning Label is in place and easy to read. Call Stamina Products immediately (1-800-375-7520) for a replacement Warning Label if the Warning Label is missing or damaged.
3. It is the sole responsibility of the user/owner to ensure that regular maintenance is performed.
4. Worn or damaged components shall be replaced immediately or the **UX2 AIR BIKE** removed from service until repair is made. Only Stamina Products supplied components shall be used to maintain/repair the **UX2 AIR BIKE**.
5. Keep your **UX2 AIR BIKE** clean by wiping with an absorbent cloth after use.

## TROUBLE SHOOTING GUIDE

**IT IS NOT NECESSARY TO RETURN ENTIRE BIKE FOR A MONITOR REPAIR.  
THE MONITOR IS REMOVABLE FROM BIKE FOR REPAIR OR REPLACEMENT.**

PROBLEM	CAUSE	CORRECTION
1. No display on monitor.	1. Batteries weak or dead.	1. Replace batteries. (Use two AA.)
2. No speed or distance displays on monitor.	1. Pickup wire not connected to monitor.	1. Securely plug pickup wire into back of monitor.
	2. Speed pickup not working properly.	2. Replace speed pickup.
	3. Monitor not working properly.	3. Replace monitor.
3. Chain makes popping noise.	1. Chain is too loose.	1. Adjust chain - See page 15 chain adjustment.
4. Bike makes sudden loud noise.	1. Chain is too loose and hits fan.	1. Adjust chain
5. Bike rocks as you pedal.	1. Bike is not level.	1. Adjust leveling caps on front stabilizer until bike is level.
6. Resistance too high.	1. Fan needs adjustment.	1. Adjust fan per instructions on page 15 and 16.

# ADJUSTMENT INSTRUCTIONS

## Chain Adjustment

Chain Adjustment required if the Chain is too loose.

1. Loosen the **NUTS(3/8"-26)(66)** on both sides of the fan.
2. Adjust the **NUT(M6x1)(65)** on the chain side of bike to remove all slack from the chain.
3. Adjust the **NUT(M6x1)(65)** on the side opposite the chain so that the center of the **NUT(3/8"-26)(66)** is the same distance from **TAB** on both sides of bike.
4. Tighten the **NUTS(3/8"-26)(66)** on both sides of the fan.

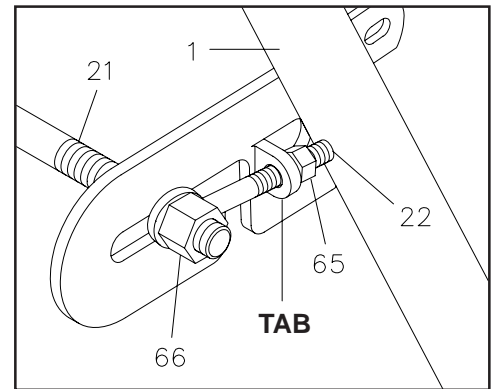

## Fan Adjustment

Fan Adjustment is required if the fan locks up or the resistance of the fan increases after use. To adjust the fan, use the following procedures:

**STEP 1:** Remove both **PEDALS(31, 32)**.

**STEP 2:** Remove the **SCREWS(52, 54, and 55)** holding the **CHAIN GUARDS(29, 30)** and **FAN CAGES(28)** to the **BIKE**. Remove the **CHAIN GUARDS(29, 30)**.

**NOTE:** The **CRANK(10)** should be pointing down.

**STEP 3:** Remove the **NUTS(3/8"-26)(66)**, **EYE BOLTS(22)**, and **NUT(M6x1)(65)** from the **FAN AXLE(21)**.

**STEP 4:** Slide the **FAN(18)** toward the rear and slide the **CHAIN(17)** off of the big sprocket on the **CRANK(10)**. Then slide the **CHAIN(17)** off of the small sprocket on the **FAN(18)**.

**STEP 5:** Unhook the **TENSION STRAP(25)** from the **FRAME(1)**. Remove the **FAN(18)** and **FAN CAGES(28)** from the bike.

**HINT:** It is best to lift the front of the frame and remove the fan and fan cages thru the bottom of the bike.

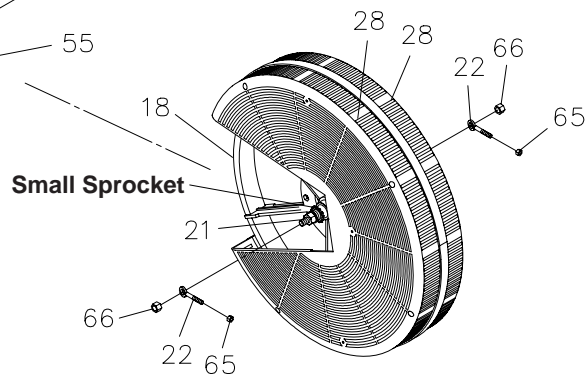
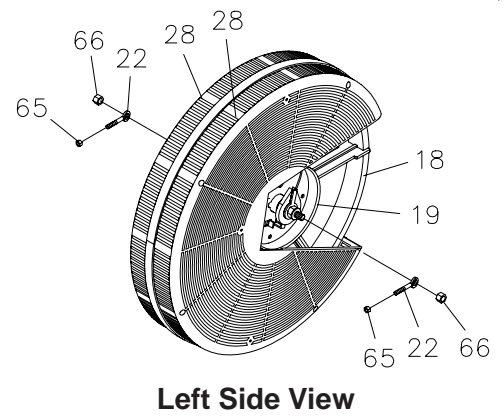
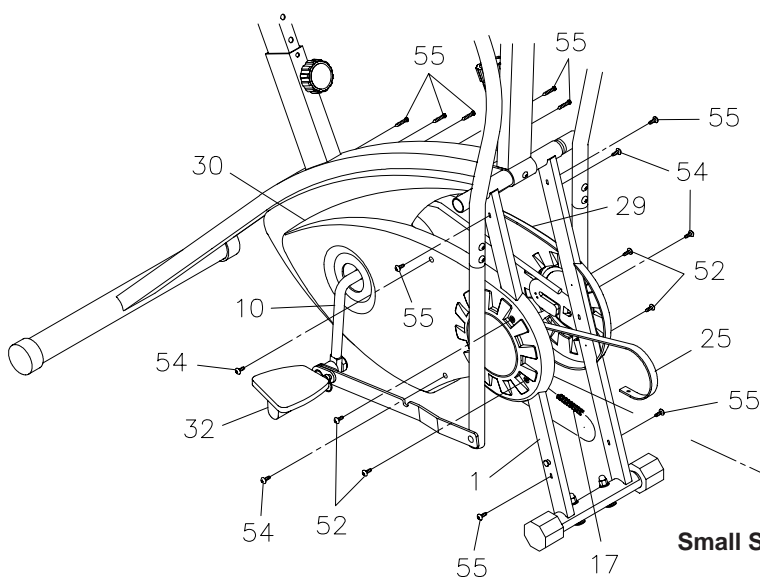



## ADJUSTMENT INSTRUCTIONS

- STEP 6:** Hold the **FAN(18)** so that the **FRONT SPROCKET** is on your left side as shown.
- STEP 7:** Loosen **NUTS "A"** and **"B"** until at least **1/2"** of **FAN AXLE** is showing between **NUT "A"** and the **FAN BUSHING**.
- STEP 8:** Tighten **NUT "C"** completely until it bottoms out on the last **FAN AXLE** thread.
- STEP 9:** Tighten **NUT "A"** completely against **FAN BUSHING**, then back off 1/4 turn or until the **FAN AXLE** has a very small amount of play side to side.
- STEP 10:** Hold **NUT "A"** and tighten **NUT "B"** completely against the **SPEED PICKUP** and **NUT "A"**.  
**NOTE:** The **FAN** should be able to spin freely on the **FAN AXLE** after completion of this step.

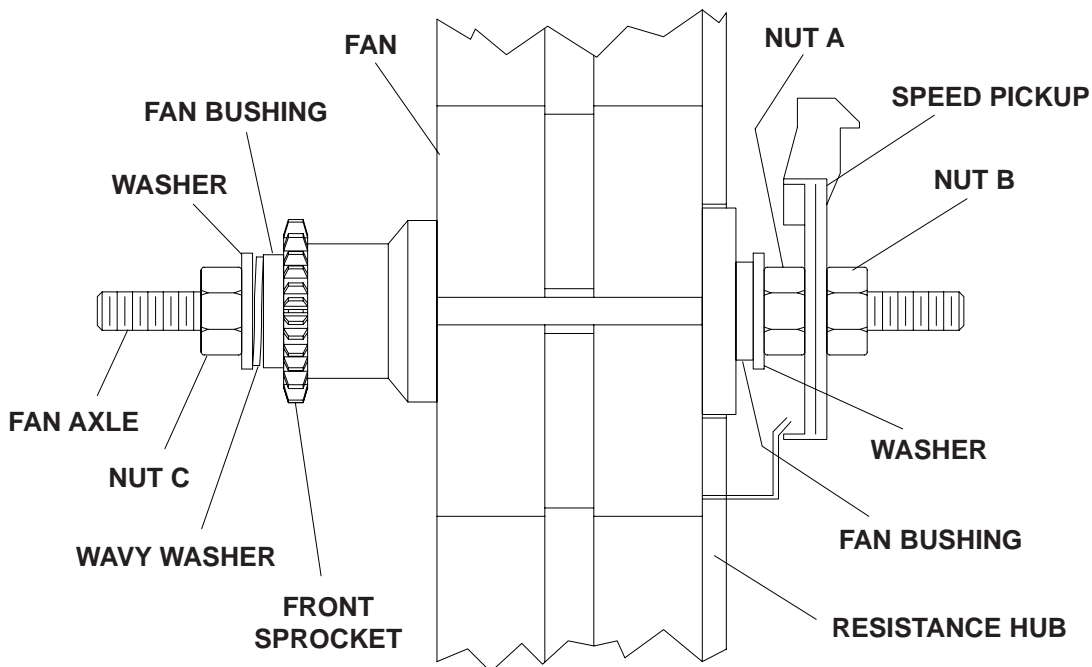

- STEP 11:** Reverse **STEPS 1** through **4** to reinstall the **FAN(18)**, **FAN CAGES(28)**, **CHAIN(17)**, and **CHAIN GUARDS (29, 30)**.  
**NOTE: DO NOT** tighten **NUTS(3/8"-26)(66)** and **NUTS (M6x1)(65)** until **STEP 11**.

**STEP 12:** The **CHAIN** must be adjusted as follows:

- Make sure the **CHAIN(17)** is on both the **FRONT** and **REAR SPROCKETS**.
- Tighten **NUT(M6x1)(65)** on **EYE BOLTS(22)** until all slack is removed from **CHAIN(17)** and **CENTER** of **NUTS(3/8")(66)** are the same distance from **TAB** on both sides of **BIKE**.
- Tighten **NUTS(3/8")(66)**.

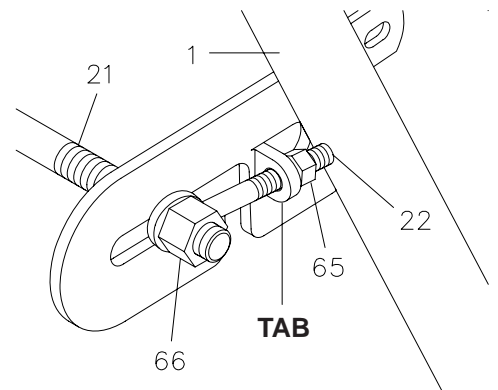

---

## CONDITIONING GUIDELINES

How you begin your exercise program depends on your physical condition. If you have been inactive for several years or are severely overweight, start slowly and increase your workout time gradually. Increase your workout intensity gradually, too, by monitoring your heart rate while you exercise.

Remember to follow these essentials:

- Have your doctor review your training and diet programs.
- Begin your training program slowly with realistic goals that have been set by you and your physician.
- Warm up before you exercise and cool down after you work out.
- Take your pulse periodically during your workout and strive to stay within a range of 60% (lower intensity) to 90% (higher intensity) of your maximum heart rate zone. Start at the lower intensity and build up to higher intensity as you become more aerobically fit.
- If you feel dizzy or lightheaded you should slow down or stop exercising.

Initially you may only be able to exercise within your target zone for a few minutes; however, your aerobic capacity will improve over the next six to eight weeks. It is important to pace yourself while you exercise so you don't tire too quickly.

To determine if you are working out at the correct intensity, use a heart rate monitor or use the table below. For effective aerobic exercise, your heart rate should be maintained at a level between 60% and 90% of your maximum heart rate. If just starting an exercise program, work out at the low end of your target heart rate zone. As your aerobic capacity improves, gradually increase the intensity of your workout by increasing your heart rate.

Measure your heart rate periodically during your workout by stopping the exercise but continuing to move your legs or walk around. Place two or three fingers on your wrist and take a six second heartbeat count. Multiply the results by ten to find your heart rate. For example, if your six second heartbeat count is 14, your heart rate is 140 beats per minute. A six second count is used because your heart rate will drop rapidly when you stop exercising. Adjust the intensity of your exercise until your heart rate is at the proper level.

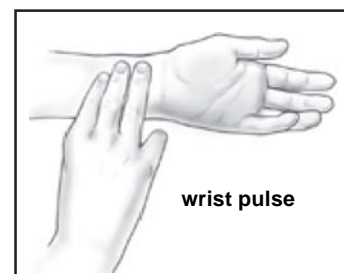

Target Heart Rate Zone Estimated by Age\*

Age	Target Heart Rate Zone (55%-90% of Maximum Heart Rate)	Average Maximum Heart Rate 100%
20 years	110-180 beats per minute	200 beats per minute
25 years	107-175 beats per minute	195 beats per minute
30 years	105-171 beats per minute	190 beats per minute
35 years	102-166 beats per minute	185 beats per minute
40 years	99-162 beats per minute	180 beats per minute
45 years	97-157 beats per minute	175 beats per minute
50 years	94-153 beats per minute	170 beats per minute
55 years	91-148 beats per minute	165 beats per minute
60 years	88-144 beats per minute	160 beats per minute
65 years	85-139 beats per minute	155 beats per minute
70 years	83-135 beats per minute	150 beats per minute

\* For cardiorespiratory training benefits, the American College of Sports Medicine recommends working out within a heart rate range of 55% to 90% of maximum heart rate. To predict the maximum heart rate, the following formula was used:  $220 - \text{Age} = \text{predicted maximum heart rate}$

---

## WARM-UP and COOL-DOWN

**Warm-up** The purpose of warming up is to prepare your body for exercise and to minimize injuries. Warm up for two to five minutes before strength-training or aerobic exercising. Perform activities that raise your heart rate and warm the working muscles. Activities may include brisk walking, jogging, jumping jacks, jump rope, and running in place

**Stretching** Stretching while your muscles are warm after a proper warm-up and again after your strength or aerobic training session is very important. Muscles stretch more easily at these times because of their elevated temperature, which greatly reduces the risk of injury. Stretches should be held for 15 to 30 seconds. Do not bounce.

### Suggested Stretching Exercises

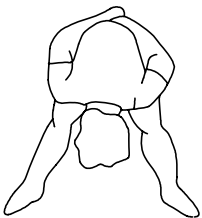

#### Lower Body Stretch

Place feet shoulder-width apart and lean forward. Keep this position for 30 seconds using the body as a natural weight to stretch the backs of the legs. **DO NOT BOUNCE!** When the pull on the back of the legs lessen, try a lower position gradually.



#### Floor Stretch

While sitting on the floor, open the legs as wide as possible. Stretch the upper body toward the knee on the right leg by using your arms to pull your chest to your thighs. Hold this stretch 10 to 30 seconds. **DO NOT BOUNCE!** Do this stretch 10 times. Repeat the stretch with the left leg.

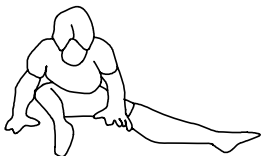

#### Bent Torso Pulls

While sitting on the floor, have legs apart one leg straight and one knee bent. Pull the chest down to touch the thigh on the leg that is bent and twist at the waist. Hold this position at least 10 seconds. Repeat 10 times on each side.

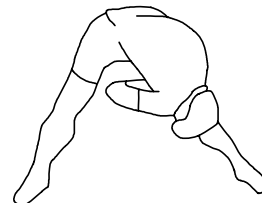
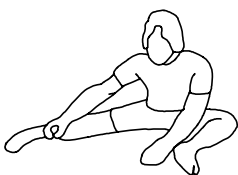

#### Bent Over Leg Stretch

Stand with feet shoulder-width apart and lean forward as illustrated. Using the arms, **gently** pull the upper body towards the right leg. Let the head hang down. **DO NOT BOUNCE!** Hold the position a minimum of 10 seconds. Repeat pulling the upper body to the left leg. Do this stretch several times slowly.

**Remember always to check with your physician before starting any exercise program.**

**Cool-Down** The purpose of cooling down is to return the body to its normal, or near normal, resting state at the end of each exercise session. A proper cool-down slowly lowers your heart rate and allows blood to return to the heart. Your cool-down should include the stretches listed above and should be completed after each strength-training session.

**WARRANTY**

Stamina Products, Inc. warrants that this product will be free from defects in materials and workmanship under normal use, service and proper operation for a period of 90 days on the parts and one year on the frame from the date of the original purchase from an authorized retailer. **THIS WARRANTY SHALL NOT APPLY TO ANY PRODUCT WHICH HAS BEEN SUBJECT TO COMMERCIAL USE, ABUSE, MISUSE, ALTERATION OF ANY TYPE OR CAUSE OR TO ANY DEFECT OR DAMAGE CAUSED BY REPAIR, REPLACEMENT, SUBSTITUTION OR USE WITH PARTS OTHER THAN PARTS PROVIDED BY STAMINA PRODUCTS, INC.** Commercial use includes use of the product in athletic clubs, health clubs, spas, gymnasiums, exercise facilities, and other public or semipublic facilities whether or not the product's use is in furtherance of a profit making enterprise, and all other use which is not for personal, family, or household purposes.

To implement this limited warranty, send a written notice stating your name, date, and place of purchase and a brief description of the defect along with your receipt to **Stamina Products, Inc. P.O. Box 1071, Springfield Missouri, USA, 65801-1071** or call us at **1 (800) 375-7520**. If the defect is covered under this limited warranty, you will be requested to return the product or part to us for free repair or replacement at our option. **NO ACTION FOR BREACH OF THIS LIMITED WARRANTY MAY BE COMMENCED MORE THAN ONE (1) YEAR AFTER THE DATE THE ALLEGED BREACH WAS OR SHOULD HAVE BEEN DISCOVERED. NO ACTION FOR BREACH OF ANY IMPLIED WARRANTY MAY BE COMMENCED MORE THAN ONE (1) YEAR AFTER DELIVERY OF THE PRODUCT TO THE PURCHASER.** This limited warranty is not transferable. **IF ANY PART OF THE PRODUCT IS NOT IN COMPLIANCE WITH THIS LIMITED WARRANTY OR ANY IMPLIED WARRANTY, THE REMEDY OF REPAIR OR REPLACEMENT IS THE EXCLUSIVE REMEDY AVAILABLE TO YOU.** In the event that the purchaser makes any claim under this limited warranty or any implied warranty, the Warrantor reserves the right to require the product to be returned for inspection, at the purchaser's expense, to the Warrantor's premises in Springfield, Missouri. Return of the enclosed warranty registration card is not required for warranty coverage, but is merely a way of establishing the date and place of purchase.

Stamina Products, Inc. **SHALL NOT BE LIABLE FOR THE LOSS OF USE OF ANY PRODUCT, LOSS OF TIME, INCONVENIENCE, COMMERCIAL LOSS OR ANY OTHER INDIRECT, CONSEQUENTIAL, SPECIAL OR INCIDENTAL DAMAGES DUE TO BREACH OF THE ABOVE WARRANTY OR ANY IMPLIED WARRANTY.**

This limited warranty is the only written or express warranty given by Stamina Products, Inc. This warranty gives you specific legal rights, and you may also have other legal rights which vary from state to state. **ANY OTHER RIGHT WHICH YOU MAY HAVE, INCLUDING ANY IMPLIED WARRANTY OR MERCHANTABILITY OR FITNESS FOR A PARTICULAR PURPOSE, IS LIMITED IN DURATION TO THE DURATION OF THIS WARRANTY.**

The laws in some jurisdictions restrict the rights of manufacturers and distributors of consumer goods to disclaim or limit implied warranties and consequential and incidental damages with respect thereto. If any such law is found to be applicable, the foregoing disclaimers and limitations of and on implied warranties and consequential and incidental damages with respect thereto shall be disregarded and shall be deemed not to have been made to the extent necessary to comply with such legal restriction.

# PRODUCT PARTS DRAWING

FRONT

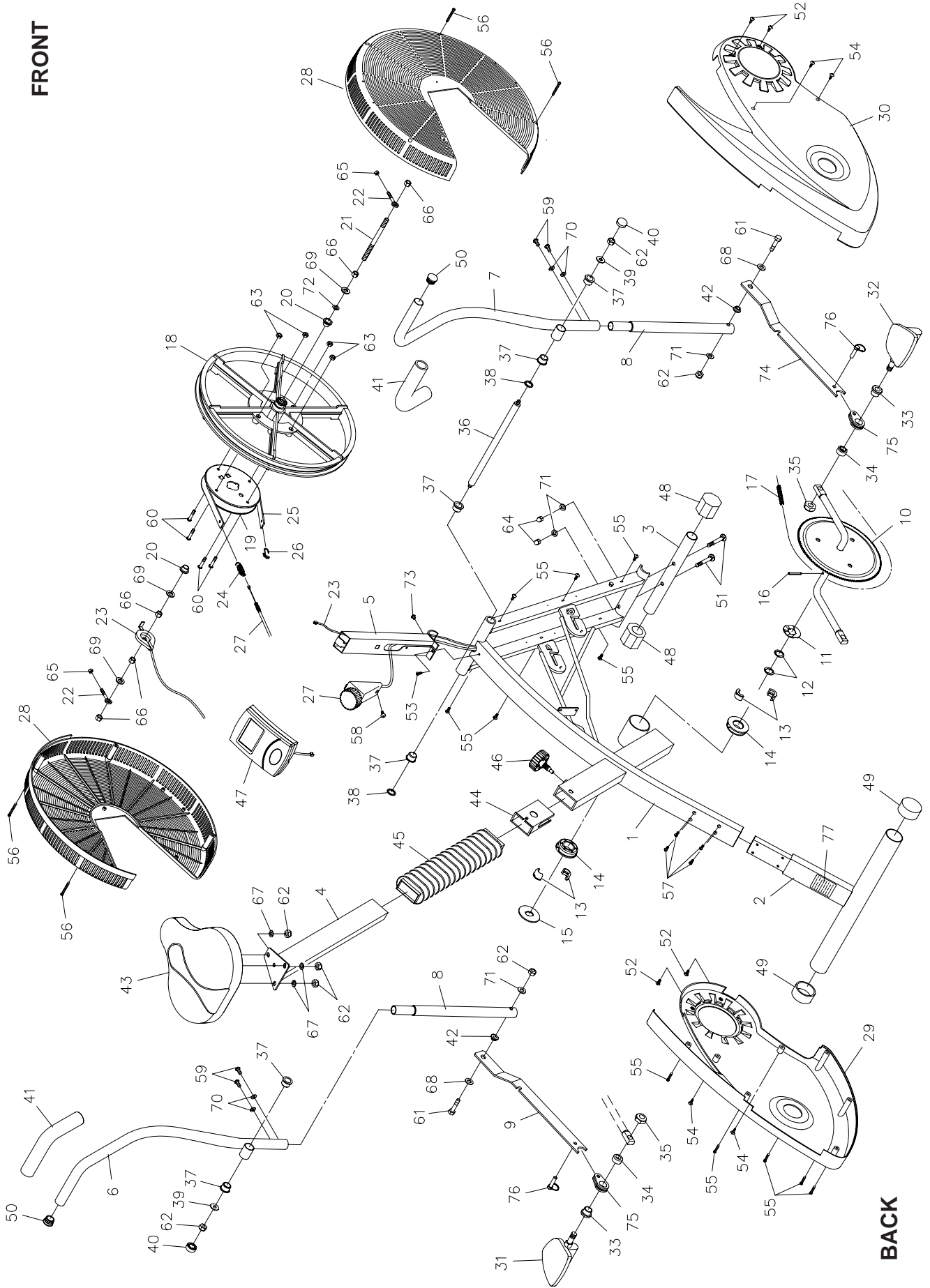

BACK

## PARTS LIST

DIAGRAM#	PART NAME	QTY
1	Main Frame	1
2	Rear Support	1
3	Front Stabilizer	1
4	Seat Post	1
5	Meter Post	1
6	Left Handlebar	1
7	Right Handlebar	1
8	Lower Bar	2
9	Left Linkage	1
10	Crank and Sprocket	1
11	Wavy Washer	1
12	Small Keyed Washer	2
13	Split Bearing	4
14	Crank Bearing Retainer	2
15	Large Keyed Washer	1
16	Roll Pin	1
17	Chain (1/4" pitch)	1
18	Fan	1
19	Resistance Hub	1
20	Fan Bushing	2
21	Fan Axle	1
22	Eye Bolt (M6 x 1 x 55mm)	2
23	Speed Pickup	1
24	Tension Spring	1
25	Tension Strap	1
26	Hook	1
27	Tension Knob	1
28	Fan Cage	2
29	Left Chain Guard	1
30	Right Chain Guard	1
31	Left Pedal /w Long Shaft	1
32	Right Pedal /w Long Shaft	1
33	Pedal Bushing	2
34	Spacer	2
35	Thin Nut (1/2"-20)	2
36	Axle	1
37	Bushing	6
38	Bushing Washer (ø16.3 x ø25mm x 0.5mm)	2
39	Large Washer (M8)	2
40	Nut Cap	2
41	Foam Grip	2
42	Linkage Bushing	2
43	Seat	1
44	Sleeve	1
45	Bellows	1
46	Locking Knob	1
47	Monitor	1

## PARTS LIST

DIAGRAM#	PART NAME	QTY
48	Leveling Cap (28.6mm)	2
49	Endcap (45mm)	2
50	Round Plug (25mm)	2
51	Carriage Bolt (M8 x 1.25 x 38mm)	2
52	Screw, Round Head (M4 x 15mm)	4
53	Screw, Round Head (M5 x 15mm)	1
54	Screw, Round Head (M5 x 15mm)	4
55	Screw, Round Head (M5 x 25mm)	11
56	Screw, Round Head (M5 x 75mm)	4
57	Screw, Round Head (M5 x 0.8 x 12mm)	4
58	Screw, Flat Head (M5 x 0.8 x 15mm)	1
59	Bolt, Round Head (M6 x 1 x 12mm)	4
60	Bolt, Round Head (M6 x 1 x 25mm)	4
61	Bolt, Hex Head (M8 x 1.25 x 45mm)	2
62	Nylock Nut (M8 x 1.25)	7
63	Nylock Nut (M6 x 1)	4
64	Acorn Nut (M8 x 1.25)	2
65	Nut (M6 x 1)	2
66	Nut (3/8" - 26)	5
67	Washer (M8 x ø16mm x 1.5mm)	3
68	Washer (M8 x ø22mm x 1.5mm)	2
69	Washer (3/8")	3
70	Arc Washer (M6)	4
71	Arc Washer (M8)	4
72	Wavy Washer (M10)	1
73	Screw, Round Head (M5 x 0.8 x 6mm)	1
74	Right Linkage	1
75	Linkage Connector	2
76	Locking Pin	2
77	Warning Label	1
78	Wrench	1
79	Multi-opening Wrench	1
80	Allen Wrench	1
81	Manual	1



