

IP-4MTS6B **(IP-4GMS6F)** **Series**

(Embedded Board)

INSTALLATION GUIDE

Installation Guide Revision A1
600700246BA10

COPYRIGHT®

All rights reserved. The information contained in this guide has been validated and reviewed for accuracy. No patent liability is assumed with respect to the use of the information contained herein. While every precaution has been taken in the preparation of this guide, the Manufacturer assumes no responsibility for errors or omissions.

No part of this publication may be reproduced, stored in a retrieval system, or transmitted in any form or by any means, electronic, mechanical, photocopying, recording, or otherwise, without the prior written permission of Manufacturer.

TRADEMARK™

Intel®, Pentium® and Celeron® are registered trademarks of Intel® Corporation.

Microsoft® and Windows® are registered trademarks of Microsoft Corporation.

All products and company names are trademarks or registered trademarks of their respective holders.

These specifications are subject to change without notice.

CONTENTS

SECTION 1	INTRODUCTION	1
1.1	Unpacking IP-4MTS6B / 4GMS6F Series	1
1.2	Description	3
1.3	Features	3
1.3.1	Graphic & Ethernet	3
1.3.2	Ultra ATA/66/100	4
1.3.3	Hardware Monitoring	4
1.3.4	I/O Shield Connector	4
1.3.5	Power-On/Off	5
1.3.6	IP-4MTS6B / IP-4GMS6F Series Overview	5
1.3.7	System Block Diagram	6
1.4	Specifications	7
1.5	Mechanical Dimensions	8
SECTION 2	INSTALLATIONS	9
2.1	System Installation	9
2.1.1	CPU Installation	9
2.1.2	Heat Sink Installation	10
2.1.3	Memory Module Installation	11
2.1.4	Setting Jumpers	13
2.2	Board Layout	14
2.3	Jumper Setting	15
2.4	Connector's Description	16

CONTENTS

SECTION 3	AWARD BIOS SETUP	33
3.1	BIOS Instructions	33
3.2	Main Menu	34
3.3	Standard CMOS Features	36
3.4	IDE Adapters	38
3.5	Advanced BIOS Features	40
3.6	Advanced Chipset Features	44
3.7	Integrated Peripherals	47
3.8	Power Management Setup	52
3.9	PnP/PCI Configurations	55
3.10	PC Health Status	57
3.11	Frequency/Voltage Control	58
3.12	Load Fail-Safe Default	59
3.13	Load Optimized Defaults	59
3.14	Supervisor/User Password Setting	60
3.15	Exit Selecting	61

SECTION 1

INTRODUCTION

1.1 Unpacking IP-4MTS6B / 4GMS6F Series

1. Take out the IP-4MTS6B / 4GMS6F series unit from the carton box, check if the unit is properly secure in the plastic bag.
2. Check the contents of the carton box:

◆ Industrial board (IP-4MTS6B)

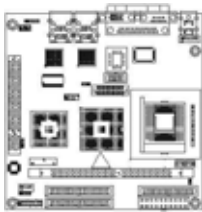

◆ Industrial board (IP-4GMS6F)

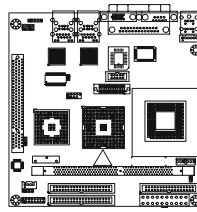

◆ ATA-66/100 HDD ribbon cable



◆ Floppy ribbon cable



◆ Installation guide



◆ Audio line-out cable



Introduction

- ◆ External K/B & M/S cable (6-pins to 6-pins)



- ◆ Driver CD



- ◆ Heat sink with fan (for IP-4MTS6B series)

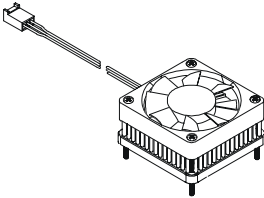

- ◆ Heat sink without fan (for IP-4GMS6F series)

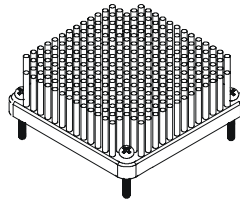

- ◆ I/O Shield



1.2 Description

The IP-4MTS6B series combines the high performance and exceptional value of Intel® 855GME chipset with a full-featured, new generation, industrial board. The Intel® advanced 855GME chipset support socket 479-pins Intel® Pentium® M / Celeron® M processor of 1.3GHz and up to 2.0GHz (Dothan™ Core), that memory base on the FSB 400 MHz operation supports DDR SDRAM interface. In the meantime, the 855GME chipset integrated the LVDS & VGA function. The IP-4MTS6B system memory size can be up to 1GB DDR memory, onboard two Intel® 82541GI Gigabit Ethernet controllers (support 10/100/1000 Base-TX Ethernet), Audio Line-Out and with 2 COM ports, besides the IP-4MTS6B with four USB2.0 ports on rear panel and two internal USB2.0 ports. They are for mini box PC, Panel PC and high-end applications. ***(IP-4GMS6F and IP-4MTS6B are the difference between on CPU onboard and core logic.)***

The 82801DB I/O Controller Hub (ICH4) employs the Intel® Accelerated Hub Architecture to make a direct connection from the graphics and memory, the IDE controllers (ATA/33 or ATA/66 or ATA/100), six USB ports that are supported USB 1.1/2.0 standard meets the performance, stability and reliability requirements.

The Mini ITX Board - IP-4MTS6B is suitable and valuable for all the industry applications, which also well support with the Windows® 98 / 2000 / XP / NT and Linux® operation system.

1.3 Features

1.3.1 Graphic & Ethernet

The IP-4MTS6B is base on the Intel® 855GME chipset, offers users the integrated LVDS, Graphic, dual Gigabit Ethernet, Audio function. The features of system are as below:

- ◆ Enhanced integrated LVDS & graphics:
 - 400 MHz FSB support
 - 24Bits single channel LVDS, resolution up to 1600 x 1200 UXGA
 - Onboard LVDS interface & CRT VGA connectors
- ◆ Build-in dual Gigabit Ethernet:
 - Onboard two Intel® Gigabit Ethernet controllers
 - Support 10/100/1000 Base-TX Ethernet

- ◆ **Memory:**
 - DDR SDRAM 200/266/333
 - 1 x 184-pins DIMM socket, with support ECC
 - 1.0GB Max.
- ◆ **IO Connectivity - ICH4:**
 - 6 Hi-Speed USB2.0 ports
 - AC97 Audio Codec

1.3.2 Ultra ATA/66/100

The ICH4 provides two channel Ultra ATA/66/100 Bus Master IDE controller, that support Ultra ATA/66/100 protocols, perfect for such demanding applications as real-time video, multimedia, and high performance operating system. A new IDE cable is required for Ultra ATA/66/100. This cable is an 80-conductor cable; however the connectors are, of course, backwards compatible with ATA/33.

1.3.3 Hardware Monitoring

Hardware monitoring allows you to monitor various aspects of your systems operations and status. The features include CPU temperature, voltage and RPM of fan.

1.3.4 I/O Shield Connector

The board is equipped with an I/O panel. Please use the appropriate I/O shield (figure 1).

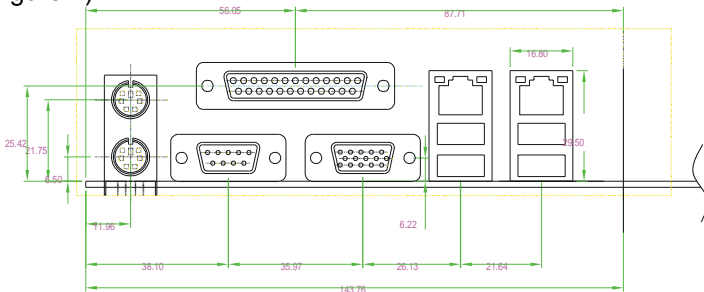

Figure 1: I/O back panel layout

1.3.5 Power-On/Off (Remote)

The board has a single 20-pins connector for ATX power supplies. For ATX power supplies that support the Remote On/Off feature, this should be connected to the systems front panel for system Power On/Off button. The systems power On/Off button should be a momentary button that is normally open.

The board has been designed with "Soft Off" functions. You can turn off the system from one of two sources: The first is the front panel Power On/Off the button, and the other is the "Soft Off" function (coming from the M/B onboard circuit controller) that can be controlled by the operating system such as Windows® 2000 / XP / NT or Linux®.

1.3.6 IP-4MTS6B / IP-4GMS6F Series Overview

Function / Model	IP-4MTS6B	IP-4GMS6F
◆ Processor	Socket Type	Onboard 600MHz (Without L2 Cache)
◆ Chipset	Intel® 855GME	Intel® 852GM
◆ LVDS function	⊙	⊙
◆ VGA function	⊙	⊙
◆ Gigabit Ethernet function	2	2
◆ Audio Line-out interface	1	1
◆ 40-pins EIDE interface	2	2
◆ Floppy interface	1	1
◆ Parallel port	1	1
◆ PCI slot	1	1
◆ Serial ports	2	2
◆ USB 2.0 ports (two for optional USB cable)	6	6
◆ Fan connector	2	2
◆ External KB/MS connector	1	1
◆ LAN Extend to front panel LED pin-header	2	2

1.3.7 System Block Diagram

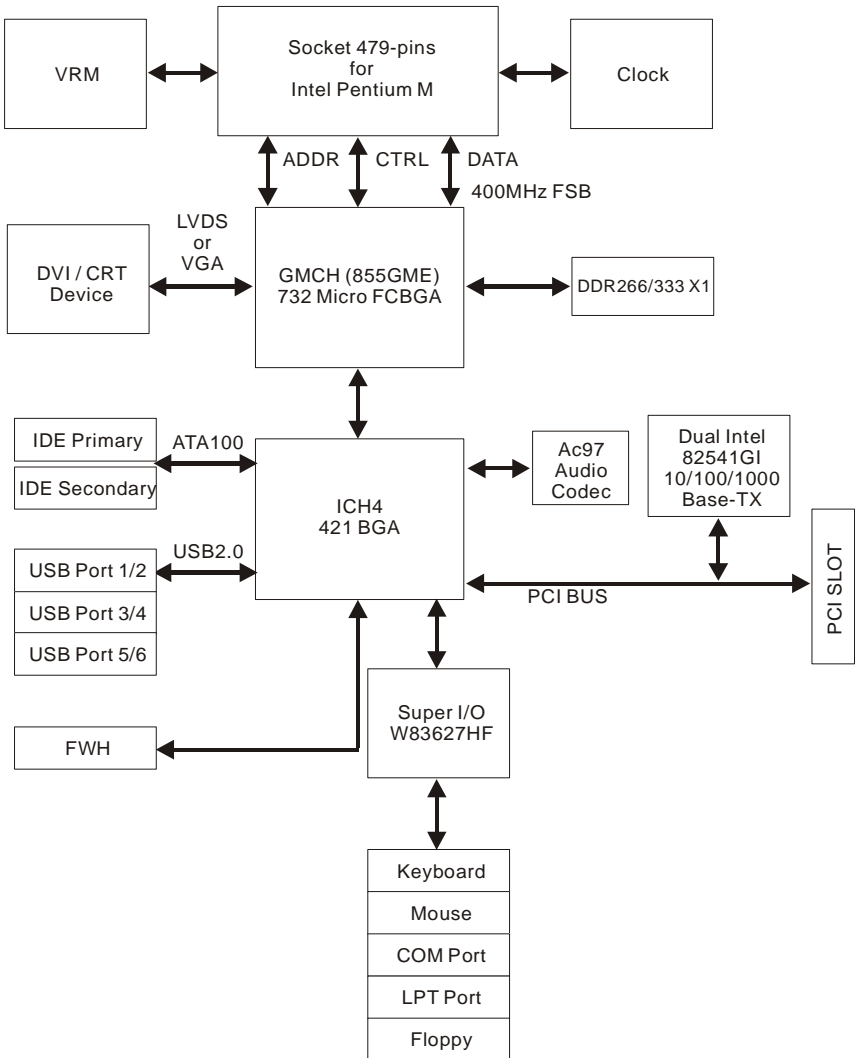

Figure 2: System Block Diagram

IP-4GMS6F onboard Celeron® M 600MHz without L2 cache processor. Core logic used the Intel® 852GM chipsets.

1.4 Specifications

◆ Processor: (IP-4MTS6B)

- Support socket 479 Intel® Pentium® M with 1MB L2 cache processor, Speed at 1.1GHz ~ 1.7GHz (Banias™ core)
- Support socket 479 Intel® Pentium® M with 2MB L2 cache processor, Speed at 1.5GHz ~ 2.0GHz (Dothan™ core)
- System bus frequency at 400 MHz FSB
- *IP-4GMS6F onboard Intel® Celeron® M 600MHz (without L2 cache)*

◆ Chipset: (IP-4MTS6B)

- Intel® 855GME + ICH4 AGPset
- *IP-4GMS6F used the Intel® 852GM + ICH4 AGPset*

◆ DRAM Module:

- 1 x 184-pins DIMM socket, Support DDR SDRAM up to 1GB (Max.)
- For DDR 200/266/333 memory

◆ LVDS & VGA Function:

- Intel® 855GME chipset integrated LVDS & graphic controller
- Support 24 bits single channel LVDS panel,
- Resolution up to 1600 x 1200 UXGA
- Onboard one 15-pins VGA connector

◆ Dual Gigabit Ethernet Function:

- Dual Intel® 82541 Ethernet controllers
- For 10/100/1000 Base-TX Ethernet
- Onboard two RJ-45 Ethernet connectors

◆ External Connector:

- 1 x 6-pins extend to front of chassis for external KB / MS connector

◆ Expansion Slot:

- 1 x PCI slot

◆ Onboard I/O:

- On-Chip I/O integrated with keyboard, mouse, parallel and serial, fast IR and power-on controller

◆ Onboard PCI / IDE:

- Intel® 82801DB (ICH4) controller
- PCI Rev2.2 compliant
- PCI bus IDE port with PIO /Ultra DMA-100 x 2 (up to 4 devices)

- ◆ **Rear I/O Connectors:**
 - PS/2 mouse and PS/2 style keyboard
 - D-Sub 25-pins printer port connector
 - D-Sub 9-pins COM1 serial port connector for RS-232
 - D-Sub 15-pins VGA connector
 - RJ-45 Ethernet (LAN1) and 2 x USB2.0 (USB 0/1) connectors
 - RJ-45 Ethernet (LAN2) and 2 x USB2.0 (USB 2/3) connectors

- ◆ **Internal I/O Connectors (pin-header):**
 - 2 x USB2.0 connectors (for optional USB cable with bracket)
 - Audio Line-out pin-header

- ◆ **Power Connector:**
 - 20-pins ATX power connector

- ◆ **BIOS:**
 - Award Plug & Play BIOS

- ◆ **Form Factor:**
 - 6.69" x 6.69" (170 x 170mm), Mini ITX size

- ◆ **Weight:**
 - 0.77lb (350g) --- IP-4MTS6B series

1.5 Mechanical Dimensions

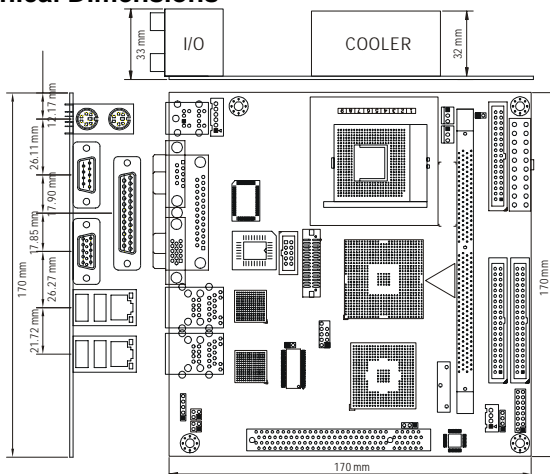

SECTION 2

INSTALLATIONS

2.1 System Installation

2.1.1 CPU Installation (IP-4MTS6B series)

Carefully follow the steps below in order to install the CPU:

1. Check and confirm that you are going to install correctly CPU type and pin numbers (figure 3).
2. Take the screwdriver and releasing screw-nut of the socket 479.
3. Rotate mark of screw-nut to face the “OPEN”.
4. Align the pins of the CPU against the pinholes of the socket 479. Be sure to pay attention to the orientation of the CPU.

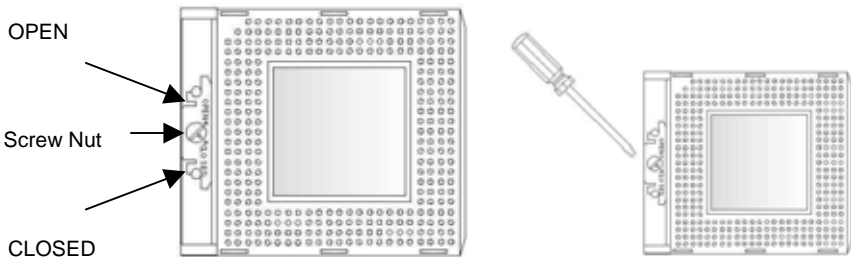

Figure 3: CPU Socket

5. Push down the CPU into the socket 479.
6. Rotate mark of screw-nut to face the “CLOSED”.
7. Place the CPU cooling fan atop the CPU surface.
8. Push down the opposite side of the ZIF clip and hook it.
9. Connect the cooling fan cable to the socket. Be careful not to place the cable on the CPU cooling fan.

Removing a CPU:

1. Before removing the CPU, turn off the IP-4MTS6B series power; then wait for about 20 minutes until the heat radiation plate of the cooling fan and the CPU cools down.
2. Rotate mark of screw-nut to face the “OPEN”.
3. To remove the CPU.

Note: The CPU and the heat radiation plate are hot. They may cause burns.

To remove the CPU, reverse the installation steps.

2.1.2 Heat Sink Installation

Make sure that good contact is made between the processors and the heat sinks & fan. Insufficient contact, incorrect types of heat sinks, fans, or thermal compound used or improper amount of thermal compound applied on the CPU die can cause the processors to overheat, which may crash the system.

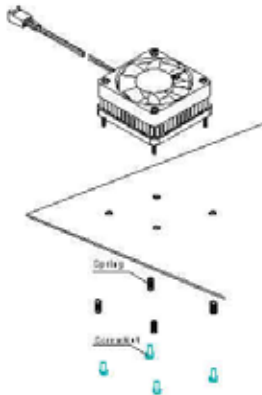

Figure 4: Heat Sink Installation

2.1.3 Memory Module Installation

Figure 5 display the notch marks and what they should look like on your DIMM memory module.

DIMMs have 184-pins and two notches, that will match with the onboard DIMM socket. DIMM modules are installed by placing the chip firmly into the socket at a 90-degree angle and pressing straight down (figure 6) until it fits tightly into the DIMM socket.

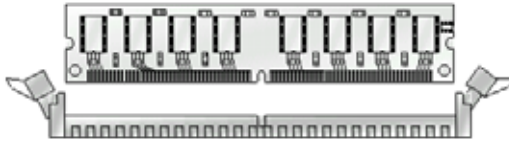

Figure 5: DIMM Memory and 184-pins Socket

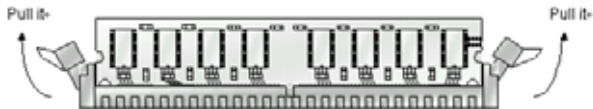

Figure 6: Memory Installation

Installations

Carefully follow the steps below in order to install the DIMMs:

1. To avoid generating static electricity and damaging the DIMM, ground yourself by touching a grounded metal surface or using a ground scrap before you touch the DIMM.
2. Do not touch the connector of the DIMM. Dirt residue may cause a malfunction.
3. Hold the DIMM with its notch to the front side of the IP-4MTS6B series and insert it completely into the socket. A DIMM should be inserted into the inner socket first. Guiding the hole at each end of the DIMM over the retaining post at each end of the DIMM socket.
4. If you install two DIMMs, install the second DIMM using the same procedure as above.
5. If DIMM does not go in smoothly, do not force it. Pull it all the way out and try again.
6. Make sure the DIMM is properly installed and locked by the tabs on both sides of the socket.

Removing a DIMM:

To remove the DIMM, use your fingers or a small screwdriver to carefully push away the plastic tabs that secure the DIMM at each end. Lift it out of the socket.

Make sure you store the DIMM in an anti-static bag and must be populated the same size and manufactory of memory modules.

2.1.4 Setting Jumpers

There are jumpers on the Embedded Board of the IP-4MTS6B series. You can set the jumpers to make the necessary operations.

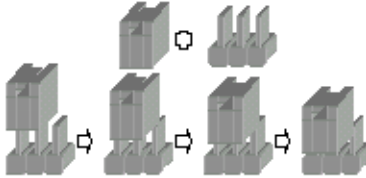
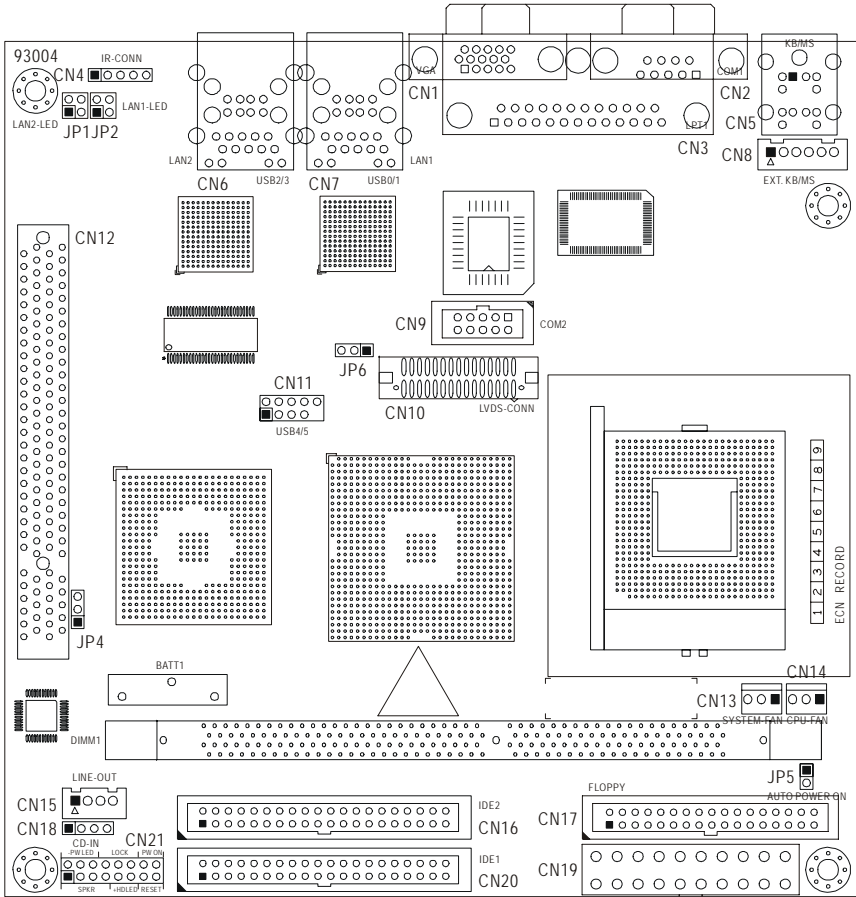

Figure 7: Jumper Connector

For any three-pins jumpers (Figure 7), the jumper setting is 1-2 when the jumper connects pins 1 and 2. The setting is 2-3 when pins 2 and 3 are connected and so on. You see one of the lines surrounding a jumper, which indicates pin NO.1.

To move a jumper from one position to another, use needle-nose pliers or tweezers to pull the pin cap off the pins and move it to the desired position.

2.2 Board Layout IP-4MTS6B Jumper & Connector Location



**IP-4GMS6F onboard Celeron[®] M 600MHz without L2 cache processor.
So the board layout has not the socket of CPU.**

2.3 Jumper Setting

Table for Jumper Location Description:

Use the information in the following table to change the jumpers.

Jumpers	Functions
JP4	Clear CMOS setting select
JP5	Auto power on setting select
JP6	LCD power setting select

In order to set up the correct configuration, here is the description about how to set the jumpers to enable/disable or change functions. All jumpers' location please refer to jumper location diagram.

◆ **Clear CMOS setting select: JP4**

Function	JP4
Normal (Default)	1-2
Clear CMOS	2-3

● **Location:**

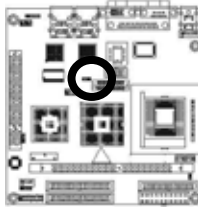

◆ **Auto power on setting select: JP5**

Function	JP4
Auto power on	On
Normal (Default)	Off

● **Location:**

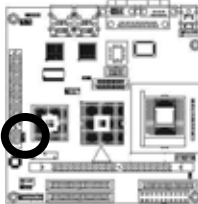

◆ LCD power setting select: JP6

Function	JP4
3.3V (Default)	1-2
5V	2-3

• Location:

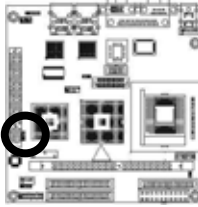

2.4 Connector's Description

IP-4MTS6B Connector Location

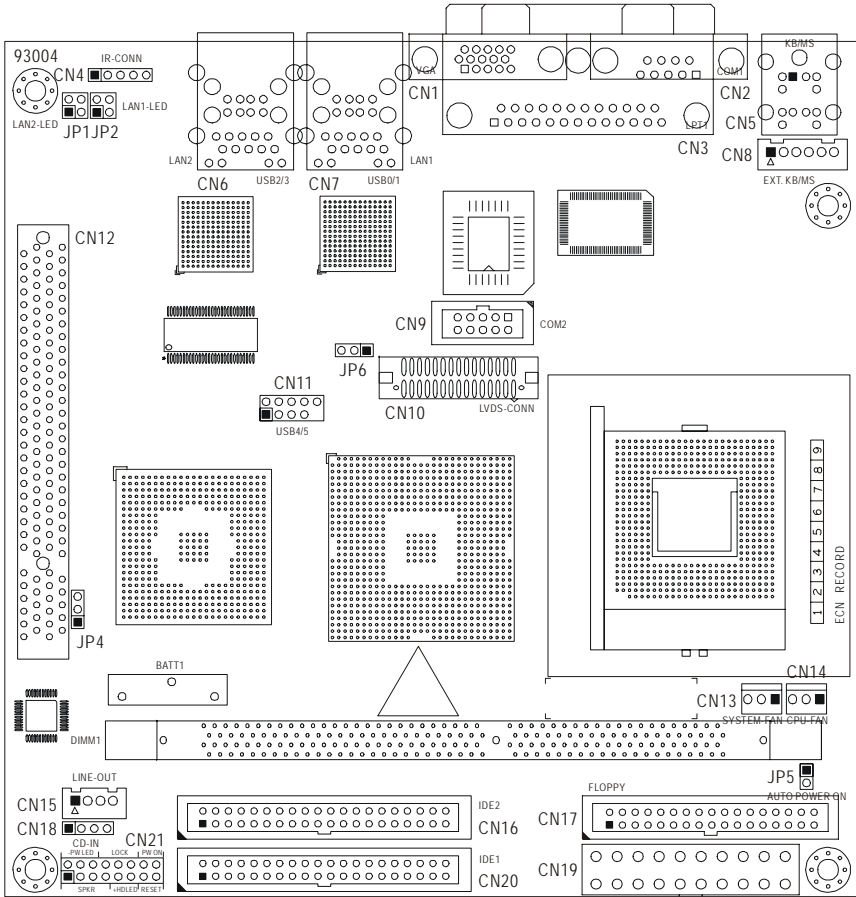

**IP-4GMS6F onboard Celeron[®] M 600MHz without L2 cache processor.
So the board layout has not the socket of CPU.**

Table for Connector's Location Description:

Use the information in the following table to change the connector.

Connectors	Functions
CN1	CRT VGA port connector
CN2	COM1 RS-232 serial port connector
CN3	Parallel port connector
CN4	IrDA connector
CN5	PS/2 keyboard & mouse connectors
CN6	USB 2/3 & Gigabit Ethernet RJ-45 (LAN2) connectors
CN7	USB 0/1 & Gigabit Ethernet RJ-45 (LAN1) connectors
CN8	External keyboard & mouse connector
CN9	COM2 RS-232 serial port connector (pin-header)
CN10	18/24Bits LVDS panel interface
CN11	USB 4/5 connector (pin-header)
CN13	System fan power connector
CN14	CPU fan power connector
CN15	Audio Line_out pin-header
CN16	Secondary IDE connector
CN17	Floppy disk connector
CN18	CD_IN pin-header
CN19	20-pins ATX power connector
CN20	Primary IDE connector
CN21	System panel indicate connector
JP1	LAN2 LED pin-header
JP2	LAN1 LED pin-header

◆ **CRT VGA port connector (D-SUB 15-pins female): CN1**

Pin #	Assignment	Pin #	Assignment
1	Red	2	Green
3	Blue	4	NC
5	Ground	6	Ground
7	Ground	8	Ground
9	VCC	10	Ground
11	NC	12	DDData
13	Hsync	14	VSync
15	DDClk		

• **Figure:**

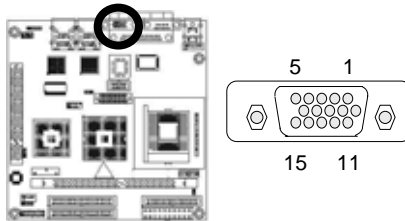

◆ **COM1 RS-232 serial port connector (D-Sub 9-pins male): CN2**

Pin #	Assignment	Pin #	Assignment
1	DCD (Data Carrier Detect)	6	DSR (Data Set Ready)
2	RXD (Receive Data)	7	RTS (Request to Send)
3	TXD (Transmit Data)	8	CTS (Clear to Send)
4	DTR (Data Terminal Ready)	9	RI (Ring Indicator)
5	Ground		

• **Figure:**

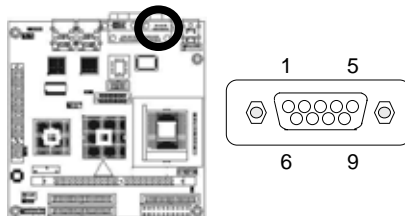

◆ **Parallel port connector (D-Sub 25-pins female): CN3**

Pin #	Assignment	Pin #	Assignment
1	Line Printer Strobe	14	Auto Feed
2	PD 0, Parallel Data 0	15	Error
3	PD 1, Parallel Data 1	16	Initialize
4	PD 2, Parallel Data 2	17	Select
5	PD 3, Parallel Data 3	18	Ground
6	PD 4, Parallel Data 4	19	Ground
7	PD 5, Parallel Data 5	20	Ground
8	PD 6, Parallel Data 6	21	Ground
9	PD 7, Parallel Data 7	22	Ground
10	ACK, Acknowledge	23	Ground
11	Busy	24	Ground
12	Paper Empty	25	Ground
13	Select		

• **Figure:**

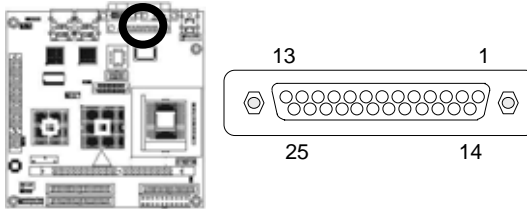

◆ **IrDA connector (5-pins pin-header): CN4**

Pin #	Assignment
1	+5V
2	FIRTX
3	IRRX
4	Ground
5	IRTX

• **Figure:**

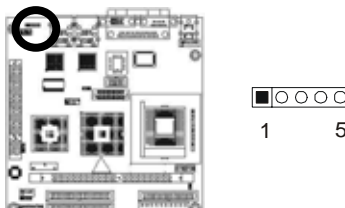

◆ **PS/2 keyboard connector (6-pins purple mini Din): CN5**

Pin #	Assignment	Pin #	Assignment
1	Keyboard data	2	NC
3	Ground	4	+5V
5	Keyboard clock	6	NC

• **Figure:**

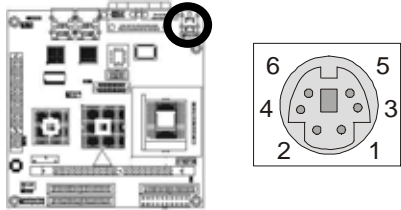

◆ **PS/2 mouse connector (6-pins green mini Din): CN5**

Pin #	Assignment	Pin #	Assignment
1	Mouse data	2	NC
3	Ground	4	+5V
5	Mouse clock	6	NC

• **Figure:**

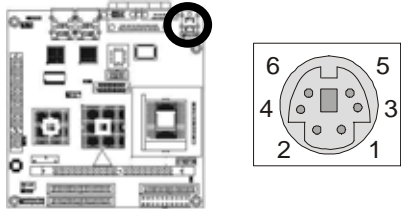

◆ Gigabit Ethernet RJ-45 (LAN2) connector (RJ-45 phone-jack): CN6

Pin #	Assignment	Pin #	Assignment
1	Transmit output (+)	5	NC
2	Transmit output (-)	6	Receive input (-)
3	Receive input (+)	7	NC
4	NC	8	NC

• Figure:

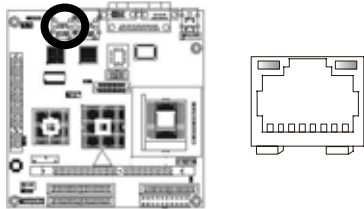

◆ USB 2/3 connectors (4-pins female): CN6

Pin #	Assignment	Pin #	Assignment
1a	VCC	1b	VCC
2a	USB2 -	2b	USB3 -
3a	USB2 +	3b	USB3 +
4a	Signal ground	4b	Signal ground

• Figure:

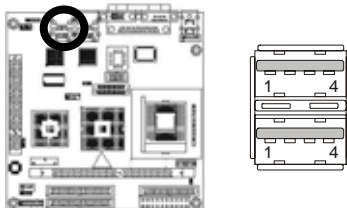

◆ Gigabit Ethernet RJ-45 (LAN1) connector (RJ-45 phone-jack): CN7

Pin #	Assignment	Pin #	Assignment
1	Transmit output (+)	5	NC
2	Transmit output (-)	6	Receive input (-)
3	Receive input (+)	7	NC
4	NC	8	NC

• Figure:

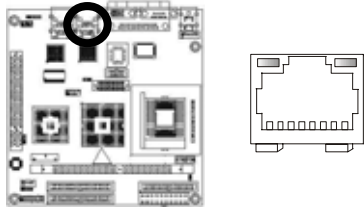

◆ USB 0/1 connectors (4-pins female): CN7

Pin #	Assignment	Pin #	Assignment
1a	VCC	1b	VCC
2a	USB0 -	2b	USB1 -
3a	USB0 +	3b	USB1 +
4a	Signal ground	4b	Signal ground

• Figure:

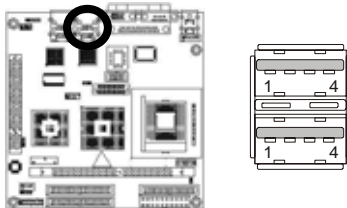

◆ External keyboard & mouse connector (6-pins pin-header): CN8

Pin #	Assignment	Pin #	Assignment
1	MS Clock	2	MS Data
3	KB Clock	4	KB Data
5	Ground	6	VCC

• Figure:

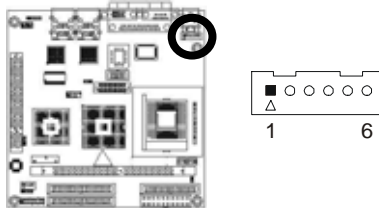

◆ COM2 RS-232 serial port connector (10-pins pin-header): CN9

Pin #	Assignment	Pin #	Assignment
1	DCD	2	DSR
2	RXD	4	RTS
3	TXD	6	CTS
4	DTR	8	RI
5	Ground	10	5V

• Figure:

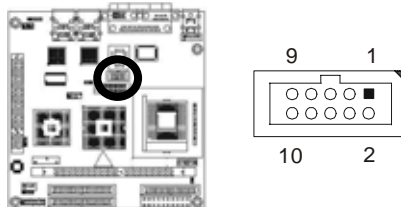

◆ 18/24Bits LVDS panel interface (40-pins male): CN10

Pin #	Assignment	Pin #	Assignment
1	NC	2	NC
3	Ground	4	Ground
5	YAM0	6	YAM1
7	YAP0	8	YAP1
9	Ground	10	Ground
11	YAM2	12	CLKAM
13	YAP2	14	CLKAP
15	Ground	16	Ground
17	YAM3	18	YBM0
19	YAP3	20	YBP0
21	Ground	22	Ground
23	YBM1	24	YBM2
25	YBP1	26	YBP2
27	Ground	28	Ground
29	CLKBM	30	YBM3
31	CLKBP	32	YBP3
33	NC	34	+12V
35	NC	36	+12V
37	NC	38	VCC_LCD
39	LCD_BKL	40	VCC_LCD

• Figure:

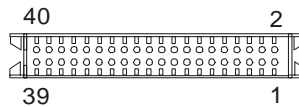
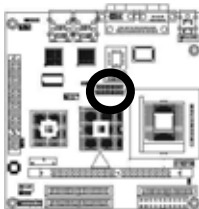

◆ USB 4/5 connector (9-pins pin-header): CN11

Pin #	Assignment	Pin #	Assignment
1	VCC	2	VCC
3	USB4 -	4	USB5 -
5	USB4 +	6	USB5 +
7	Ground	8	Ground
9	---	10	NC

• Figure:

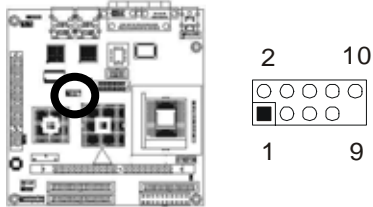

◆ System fan power connector: CN13

Pin #	Assignment
1	Ground
2	VCC
3	Fan Status Signal

• Figure:

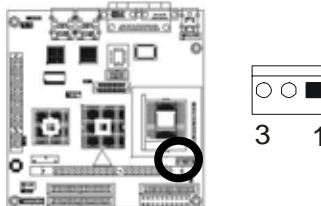

◆ CPU fan power connector: CN14

Pin #	Assignment
1	Ground
2	VCC
3	Fan Status Signal

• Figure:

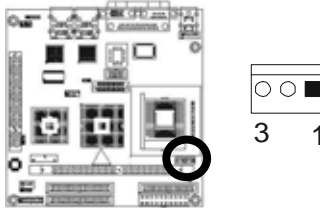

◆ Audio Line_out pin-header: CN15

Pin #	Assignment
1	LOUT_L
2	Ground
3	Ground
4	LOUT_R

• Figure:

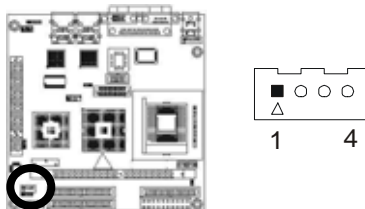

◆ **Secondary IDE connector (40-pins 2.54mm pitch pin-header with housing): CN16**

Pin #	Assignment	Pin #	Assignment
1	Reset IDE	2	Ground
3	Host Data 7	4	Host Data 8
5	Host Data 6	6	Host Data 9
7	Host Data 5	8	Host Data 10
9	Host Data 4	10	Host Data 11
11	Host Data 3	12	Host Data 12
13	Host Data 2	14	Host Data 13
15	Host Data 1	16	Host Data 14
17	Host Data 0	18	Host Data 15
19	Ground	20	---
21	DRQ 1	22	Ground
23	Host IOW	24	Ground
25	Host IOR	26	Ground
27	IOCHRDY	28	Host ALE
29	DACK 1	30	Ground
31	IRQ 15	32	NC
33	Address 1	34	Ground
35	Address 0	36	Address 2
37	Chip Select 0	38	Chip Select 1
39	Activity	40	Ground

● **Figure:**

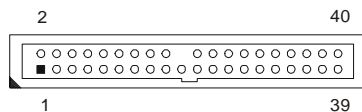
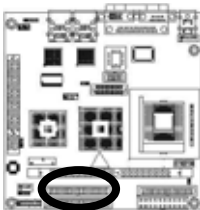

◆ Floppy disk connector (34-pins 2.54mm pitch pin-header with housing): CN17

Pin #	Assignment	Pin #	Assignment
1	Ground	2	Drive Density Selection
3	Ground	4	NC
5	Ground	6	Drive Density Selection
7	Ground	8	Index
9	Ground	10	Motor Enable 0
11	Ground	12	Drive Select 1
13	Ground	14	Drive Select 0
15	Ground	16	Motor Enable 1
17	Ground	18	Direction
19	Ground	20	Step
21	Ground	22	Write Data
23	Ground	24	Write Gate
25	Ground	26	Track 00
27	Ground	28	Write Protect
29	NC	30	Read Data
31	Ground	32	Head Select
33	NC	34	Diskette Change

• Figure:

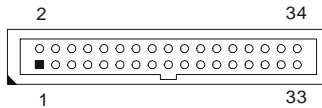
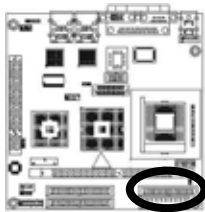

◆ CD_IN pin-header: CN18

Pin #	Assignment
1	CD_IN_Left
2	CD_GND
3	CD_GND
4	CD_IN_Right

• Figure:

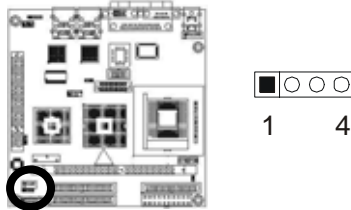

◆ 20-pins ATX power connector: CN19

Pin #	Assignment	Pin #	Assignment
1	+3.3V	11	+3.3V
2	+3.3V	12	-12V
3	Ground	13	Ground
4	+5V	14	PS-ON
5	Ground	15	Ground
6	+5V	16	Ground
7	Ground	17	Ground
8	NC	18	-5V
9	5VSB	19	+5V
10	+12V	20	+5V

• Figure:

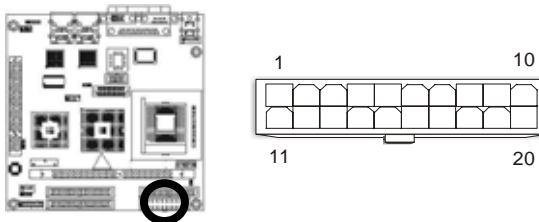

◆ **Primary IDE connector (40-pins 2.54mm pitch pin-header with housing): CN20**

Pin #	Assignment	Pin #	Assignment
1	Reset IDE	2	Ground
3	Host Data 7	4	Host Data 8
5	Host Data 6	6	Host Data 9
7	Host Data 5	8	Host Data 10
9	Host Data 4	10	Host Data 11
11	Host Data 3	12	Host Data 12
13	Host Data 2	14	Host Data 13
15	Host Data 1	16	Host Data 14
17	Host Data 0	18	Host Data 15
19	Ground	20	---
21	DRQ 0	22	Ground
23	Host IOW	24	Ground
25	Host IOR	26	Ground
27	IOCHRDY	28	Host ALE
29	DACK 0	30	Ground
31	IRQ 14	32	No Connect
33	Address 1	34	Ground
35	Address 0	36	Address 2
37	Chip Select 0	38	Chip Select 1
39	Activity	40	Ground

● **Figure:**

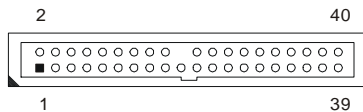
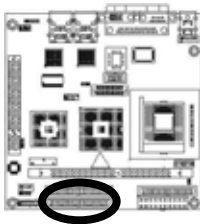

◆ System panel indicate connector: CN21

Pin #	Assignment	Pin #	Assignment
SPEAKER		PWR LED	
1	+5V	2	5V
3	NC	4	NC
5	BZ	6	Ground
7	SPKR	KEYLOCK	
HDD LED		8	KBLOCK
9	5V	10	Ground
11	HDLED-	12	NC
RESET		PWR ON	
13	RESET+	14	5VSB
15	Ground	16	PWRBT-

• Figure:

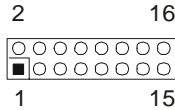
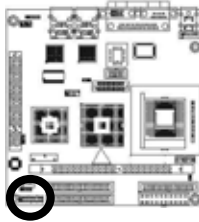

◆ LAN2 LED pin-header: JP1

Pin #	Assignment	Pin #	Assignment
1	LINK_LED	2	VCC_3V
3	ACT_LED	4	VCC_3V

• Figure:

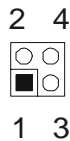
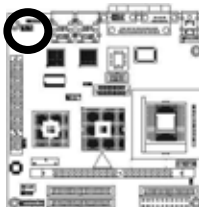

◆ LAN1 LED pin-header: JP2

Pin #	Assignment	Pin #	Assignment
1	LINK_LED	2	VCC_3V
3	ACT_LED	4	VCC_3V

• Figure:

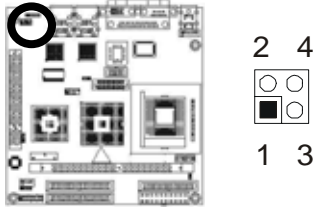

The graphic consists of three overlapping rectangular boxes, each containing the text 'SECTION 3'. The boxes are stacked and slightly offset to the right, creating a layered effect.

SECTION 3

AWARD BIOS SETUP

3.1 BIOS Instructions

Award's ROM BIOS provides a built-in Setup program, which allows user to modify the basic system configuration and hardware parameters. The modified data will be stored in a battery-backed CMOS, so that data will be retained even when the power is turned off. In general, the information saved in the CMOS RAM will stay unchanged unless there is a configuration change in the system, such as hard drive replacement or a device is added.

It is possible for the CMOS battery to fail, this will cause data loss in the CMOS only. If this does happen you will need to reconfigure your BIOS settings.

3.2 Main Menu

Once you enter the AwardBIOS™ CMOS Setup Utility, the Main Menu will appear on the screen. The Main Menu allows you to select from several setup functions and two exit choices. Use the arrow keys to select among the items and press <Enter> to accept and enter the sub-menu.

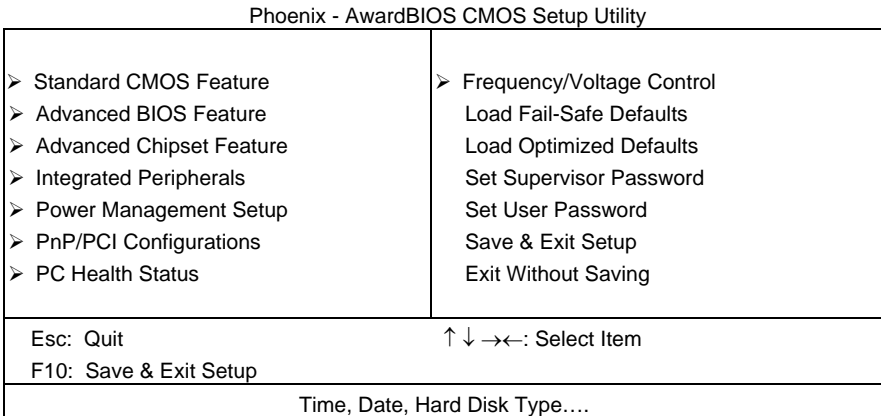

Note: that a brief description of each highlighted selection appears at the bottom of the screen.

Setup Items:

The main menu includes the following main setup categories. Recall that some systems may not include all entries.

Standard CMOS Features:

Use this menu for basic system configuration. See 3.3 for the details.

Advanced BIOS Features:

Use this menu to set the Advanced Features available on your system. See 3.5 for the details.

Advanced Chipset Features:

Use this menu to change the values in the chipset registers and optimize your system's performance. See 3.6 for the details.

Integrated Peripherals:

Use this menu to specify your settings for integrated peripherals. See 3.7 for the details.

Power Management Setup:

Use this menu to specify your settings for power management. See 3.8 for the details.

PnP / PCI Configuration:

This entry appears if your system supports PnP / PCI. See 3.9 for the details.

PC Health Status:

Use this menu to show your system temperature, speed and voltage status. See 3.10 for the details.

Frequency / Voltage Control:

Use this menu to specify your settings for frequency/voltage control. See 3.11 for the details.

Load Fail-Safe Defaults:

Use this menu to load the BIOS default values for the minimal/stable performance for your system to operate. See 3.12 for the details.

Load Optimized Defaults:

Use this menu to load the BIOS default values that are factory settings for optimal performance system operations. While Award has designed the custom BIOS to maximize performance, the factory has the right to change these defaults to meet their needs. See 3.13 for the details.

Supervisor / User Password:

Use this menu to set User and Supervisor Passwords. See 3.14 for the details.

Save & Exit Setup:

Save CMOS value changes to CMOS and exit setup. See 3.15 for the details.

Exit Without Save:

Abandon all CMOS value changes and exit setup. See 3.15 for the details.

3.3 Standard CMOS Features

The items in Standard CMOS Setup Menu are divided into 10 categories. Each category includes no, one or more than one setup items. Use the arrow keys to highlight the item and then use the <PgUp> or <PgDn> keys to select the value you want in each item.

Phoenix - AwardBIOS CMOS Setup Utility
Standard CMOS Features

Date (mm:dd:yy):	Mon, Aug 4 2003	Item Help
Time (hh:mm:ss):	16:19:20	
➤ IDE Primary Master	13579 MB	Menu Level ➤
➤ IDE Primary Slave	None	
➤ IDE Secondary Master	None	Change the day, month, year and century
➤ IDE Secondary Slave	None	
Drive A	1.44M, 3.5 in.	
Drive B	None	
Video	EGA/VGA	
Halt On	All, But Keyboard	
Based Memory	640K	
Extended Memory	515072K	
Total Memory	516096K	
↑↓→←Move Enter: Select +/-/PU/PD: Value F10: Save ESC: Exit F1: General Help F5: Previous Values F6: Fail-safe defaults F7: Optimized Defaults		

Date: Options Month/DD/YYYY

Set the system date. Note that the 'Day' automatically changes when you set the date.

Time: Options HH : MM : SS

Set the system time.

IDE Primary Master: Options are in its sub menu (described in 3.4)

Press <Enter> to enter the sub menu of detailed options.

IDE Primary Slave: Options are in its sub menu (described in 3.4)

Press <Enter> to enter the sub menu of detailed options.

IDE Secondary Master: Options are in its sub menu (described in 3.4)
Press <Enter> to enter the sub menu of detailed options.

IDE Secondary Master: Options are in its sub menu (described in 3.4)
Press <Enter> to enter the sub menu of detailed options.

Drive A/ Drive B: Options None 360K, 5.25 in/1.2M, 5.25 in/720K, 3.5 in/
1.44M, 3.5 in/2.88M, 3.5 in
Select the type of floppy disk drive installed in your system.

Video: Options EGA/VGA/CGA 40/CGA 80/MONO
Select the default video device.

Halt On: Options All Errors/No Errors/All, but Keyboard/All, but Diskette/All,
but Disk/Key
Select the situation in which you want the BIOS to stop the POST process
and notify you.

Base Memory: Option N/A
Displays the amount of conventional memory detected during boot up.

Extended Memory: Option N/A
Displays the amount of extended memory detected during boot up

Total Memory: Option N/A
Displays the total memory available in the system

3.4 IDE Adapters

The IDE adapters control the hard disk drive. Use a separate sub menu to configure each hard disk drive.

Phoenix - AwardBIOS CMOS Setup Utility

IDE Primary Master

IDE HDD Auto-Detection	Press Enter	Item Help
IDE Primary Master Access Mode	Auto Auto	Menu Level >>
Capacity	13579 MB	To auto-detect the HDD's size, head... on this channel
Cylinder	26310	
Head	16	
Precomp	0	
Landing Zone	26309	
Sector	63	
↑↓→← Move Enter: Select +/-PU/PD: Value F10: Save ESC: Exit F1: General Help F5: Previous Values F6: Fail-safe defaults F7: Optimized Defaults		

IDE HDD Auto-Detection: Options Press Enter

Press Enter to auto-detect the HDD on this channel. If detection is successful, it fills the remaining fields on this menu.

IDE Primary Master: Options None, Auto and Manual

Selecting "Manual" lets you set the remaining fields on this screen. Selects the type of fixed disk. "User Type" will let you select the number of cylinders, heads, etc. Note: PRECOMP=65535 means NONE!

Access Mode: Options CHS, LBA, Large and Auto

Choose the access mode for this hard disk

Capacity: Options Auto Display your disk drive size

Disk drive capacity (Approximated). Note that this size is usually slightly greater than the size of a formatted disk given by a disk-checking program.

The following options are selectable only if the 'IDE Primary Master' item is set to 'Manual'

Cylinder: Options Min = 0, Max = 65535

Set the number of cylinders for this hard disk.

Head: Options Min = 0, Max = 255

Set the number of read/write heads

Precomp: Options Min = 0, Max = 65535

**** **Warning:** Setting a value of 65535 means no hard disk

Landing zone: Options Min = 0, Max = 65535

Sector: Options Min = 0, Max = 255

Number of sectors per track

3.5 Advanced BIOS Features

This section allows you to configure your system for basic operation. You have the opportunity to select the system’s default speed, boot-up sequence, keyboard operation, shadowing and security.

Phoenix - AwardBIOS CMOS Setup Utility
Advanced BIOS Features

> CPU Feature Virus Warning CPU L1 & L2 Cache Quick Power On Self Test First Boot Device Second Boot Device Third Boot Device Boot Other Device Swap Floppy Drive Boot Up Floppy Seek Boot Up NumLock Status Gate A20 Option Typematic Rate Setting X Typematic Rate (Chars/Sec) X Typematic Delay (Msec) Security Option APIC Mode MPS Version Control For OS OS Select For DRAM > 64MB Report No FDD For WIN95	Press Enter Disabled Enabled Enabled CDROM HDD-0 LS-120 Enabled Disabled Enabled On Fast Disabled 6 250 Setup Enabled 1.4 Non-OS2 No	Item Help <hr/> Menu Level >
↑↓→←Move Enter: Select +/-/PU/PD: Value F10: Save ESC: Exit F1: General Help F5: Previous Values F6: Fail-safe defaults F7: Optimized Defaults		

CPU Feature:

Phoenix - AwardBIOS CMOS Setup Utility
CPU Feature

Thermal Management	Thermal Monitor 1	Item Help <hr/> Menu Level >>
↑↓→←Move Enter: Select +/-/PU/PD: Value F10: Save ESC: Exit F1: General Help F5: Previous Values F6: Fail-safe defaults F7: Optimized Defaults		

Thermal Management:

It allows you to select the thermal Monitor.

The Choice: Thermal monitor1, thermal Monitor2.

Virus Warning:

Allow you to choose the virus-warning feature for IDE Hard Disk boot sector protection. If this function is enabled and someone attempts to write data into this area, BIOS will show a warning message on screen and alarm beep.

Enabled---Activates automatically when the system boots up causing a warning message to appear when anything attempts to access the boot sector or hard disk partition table.

Disabled---No warning message will appear when anything attempts to access the boot sector or hard disk partition table.

CPU L1& L2 Cache:

This controls the status of the processor's internal Level One and Level Two cache. However, it depends on CPU chipset design.

Enabled---Enable cache

Disabled---Disable cache

Quick Power On Self Test:

This category speeds up Power On Self Test (POST) after you power up the computer. If it is set to Enable, BIOS will shorten or skip some check items during POST.

Enabled---Enable quick POST

Disabled--- Normal POST

First / Second / Third Boot Device:

The BIOS attempts to load the operating system from the devices in the sequence selected in these items.

The Choice: Floppy, LS/ZIP, HDD, SCSI, CDROM, LAN and Disabled.

Boot Other Device:

When enabled, the system searches all other possible locations for an operating system if it fails to find one in the devices specified under the first, second, and third boot devices.

The Choice: Enabled, Disabled.

Swap Floppy Drive:

If the system has two floppy drives, you can swap the logical drive name assignments.

The choice: Enabled, Disabled.

Boot Up Floppy Seek:

Seeks disk drives during boot up. Disabling speeds boot up.

The choice: Enabled, Disabled.

Boot Up NumLock Status:

Select power on state for NumLock.

The choice: On, Off.

Gate A20 Option:

Select if chipset or keyboard controller should control GateA20.

Normal---A pin in the keyboard controller controls GateA20.

Fast---Lets chipset control GateA20.

Typematic Rate Setting:

Keystrokes repeat at a rate determined by the keyboard controller. When enabled, the typematic rate and typematic delay can be selected.

The choice: Enabled, Disabled.

Typematic Rate (Chars/Sec):

Sets the number of times a second to repeat a keystroke when you hold the key down.

The choice: 6, 8, 10, 12, 15, 20, 24 and 30.

Typematic Delay (Msec):

Sets the delay time after the key is held down before it begins to repeat the keystroke.

The choice: 250, 500, 750 and 1000.

Security Option:

Select whether the password is required every time the system boots or only when you enter setup.

System---The system will not boot and access to Setup will be denied if the correct password is not entered at the prompt.

Setup---The system will boot, but access to Setup will be denied if the correct password is not entered at the prompt.

Note: To disable security, select PASSWORD SETTING at Main Menu and then you will be asked to enter password. Do not type anything and just press <Enter>, it will disable security. Once the security is disabled, the system will boot and you can enter Setup freely.

APIC Mode:

This item allows you to enable APIC (Advanced Programmable Interrupt Controller) functionality. APIC is an Intel chip that provides symmetric multiprocessing (SMP) for its Pentium systems.

The Choice: Enabled, Disabled.

MPS Version Control For OS:

This item allows you to select the version of the Intel multiprocessor specification supported by the operating system running on this computer.

The Choice: 1.1, 1.4.

OS Select For DRAM > 64MB:

Select the operating system that is running with greater than 64MB of RAM on the system.

The choice: Non-OS2, OS2.

Report No FDD For WIN95:

Whether report no FDD for Win 95 or not.

The choice: Yes, No.

3.6 Advanced Chipset Features

This section allows you to configure the system based on the specific features of the installed chipset. This chipset manages bus speeds and access to system memory resources, such as DRAM and the external cache. It also coordinates communications between the conventional ISA bus and the PCI bus. It must be stated that these items should never need to be altered. The default settings have been chosen because they provide the best operating conditions for your system. The only time you might consider making any changes would be if you discovered that data was being lost while using your system.

Phoenix - AwardBIOS CMOS Setup Utility
Advanced Chipset Features

		Item Help
DRAM Timing Selectable	By SPD	
X CAS Latency Time	2.5	
X Active To Precharge Delay	7	
X DRAM RAS# To CAS# Delay	3	Menu Level ➤
X DRAM RAS# Precharge	3	
DRAM Data Integrity Mode	Non-ECC	
MGM Core Frequency	Auto Max 266MHz	
System BIOS Cacheable	Enabled	
Video BIOS Cacheable	Disabled	
Memory Hole At 15M-16M	Disabled	
Delayed Transaction	Enabled	
Delay Prior To Thermal	16Min.	
AGP Aperture Size (MB)	64	
** On-Chip VGA Setting **		
On-Chip VGA	Enabled	
On-Chip Frame Buffer Size	32MB	
Boot Display	CRT	
Panel Scaling	Auto	
↑↓←→Move Enter: Select +/-/PU/PD: Value F10: Save ESC: Exit F1: General Help F5: Previous Values F6: Fail-safe defaults F7: Optimized Defaults		

DRAM Timing Selectable:

Select the operating system that is selecting DRAM timing, so select SPD for setting SDRAM timing by SPD.

The choice: Manual, By SPD.

CAS Latency Time:

When synchronous DRAM is installed, the number of clock cycles of CAS latency depends on the DRAM timing.

The choice: 2, 2.5.

Active To Precharge Delay:

Select the operating system that is active to precharge delay.

The choice: 5, 6, 7.

DRAM RAS# To CAS# Delay:

This field let's you insert a timing delay between the CAS and RAS strobe signals, used when DRAM is written to, read from, or refreshed. Fast gives faster performance; and Slow gives more stable performance. This field applies only when synchronous DRAM is installed in the system.

The choice: 2, 3.

DRAM RAS# Precharge:

If an insufficient number of cycles are allowed for the RAS to accumulate its charge before DRAM refresh, the refresh may be incomplete and the DRAM may fail to retain data. Fast gives faster performance; and Slow gives more stable performance. This field applies only when synchronous DRAM is installed in the system.

The choice: 2, 3.

DRAM Data Integrity Mode:

This item shows you the Dram have ECC function or not.

The choice: Non-ECC, ECC.

MGM Core Frequency:

This item allows you to determine the MGM core frequency.

The choice: Auto Max 266MHz, 400/266/133/200MHz,
400/200/100/200MHz, 400/200/100/133MHz,
400/266/133/267MHz, 400/333/166/250MHz,
Auto Max 400/333.

System BIOS Cacheable:

Selecting "Enabled" allows caching of the system BIOS ROM at F0000h-FFFFFh, resulting in better system performance. However, if any program writes to this memory area, a system error may result.

The choice: Enabled, Disabled.

Video BIOS Cacheable:

Select "Enabled" allows caching of the video BIOS, resulting in better system performance. However, if any program writes to this memory area, a system error may result.

The choice: Enabled, Disabled.

Memory Hole At 15M-16M:

You can reserve this area of system memory for ISA adapter ROM. When this area is reserved, it cannot be cached. The user information of peripherals that need to use this area of system memory usually discusses their memory requirements.

The choice: Enabled, Disabled.

Delayed Transaction:

The chipset has an embedded 32-bit posted write buffer to support delay transactions cycles. Select "Enabled" to support compliance with PCI specification version 2.2.

The choice: Enabled, Disabled.

Delay Prior To Thermal:

Select this item allows the delay prior to thermal time.

The choice: 4Min, 8Min, 16Min and 32Min.

AGP Aperture Size (MB):

This field determines the effective size of the Graphic Aperture used for a particular GMCH configuration. It can be updated by the GMCH-specific BIOS configuration sequence before the PCI standard bus enumeration sequence takes place. If it is not updated then a default value will select an aperture of maximum size.

The choice: 4, 8, 16, 32, 64, 128 and 256.

****On-Chip VGA Setting****

On-Chip VGA:

This item allows you to control the on-chip VGA.

The choice: Enabled, Disabled.

On-Chip Frame Buffer Size:

This item allows you to control the on-chip frame buffer size.

The choice: 1M, 4M, 8M, 16M and 32M.

Boot Display:

This item allows you to select the boot display device.

The choice: CRT, LFP and CRT+LFP.

Panel Scaling:

This item allows you to select the panel scale.

The choice: Auto, On, Off.

3.7 Integrated Peripherals

Phoenix - AwardBIOS CMOS Setup Utility

Integrated Peripherals

<ul style="list-style-type: none"> ➤ OnChip IDE Device Press Enter ➤ Onboard Device Press Enter ➤ SuperI/O Device Press Enter Onboard Lan Boot ROM Disabled 	<table border="1"> <tr> <td style="text-align: center;">Item Help</td> </tr> <tr> <td style="border-top: 1px solid black;">Menu Level ➤</td> </tr> </table>	Item Help	Menu Level ➤
Item Help			
Menu Level ➤			
↑↓←→Move Enter: Select +/-/PU/PD: Value F10: Save ESC: Exit F1: General Help F5: Previous Values F6: Fail-safe defaults F7: Optimized Defaults			

OnChip IDE Device:

OnChip IDE Device

<ul style="list-style-type: none"> On-Chip Primary PCI IDE Enabled IDE Primary Master PIO Auto IDE Primary Slave PIO Auto IDE Primary Master UDMA Auto IDE Primary Slave UDMA Auto On-Chip Secondary PCI IDE Enabled IDE Secondary Master PIO Auto IDE Secondary Slave PIO Auto IDE Secondary Master UDMA Auto IDE Secondary Slave UDMA Auto IDE HDD Block Mode Enabled 	<table border="1"> <tr> <td style="text-align: center;">Item Help</td> </tr> <tr> <td style="border-top: 1px solid black;">Menu Level ➤</td> </tr> </table>	Item Help	Menu Level ➤
Item Help			
Menu Level ➤			
↑↓←→Move Enter: Select +/-/PU/PD: Value F10: Save ESC: Exit F1: General Help F5: Previous Values F6: Fail-safe defaults F7: Optimized Defaults			

OnChip Primary/Secondary PCI IDE:

The integrated peripheral controller contains an IDE interface with support for two IDE channels. Select "Enabled" to activate each channel separately.

The choice: Enabled, Disabled.

IDE Primary/Secondary Master/Slave PIO:

The four IDE PIO (Programmed Input/Output) fields let you set a PIO mode (0-4) for each of the four IDE devices that the onboard IDE interface supports. Modes 0 through 4 provide successively increased performance. In Auto mode, the system automatically determines the best mode for each device.

The choice: Auto, Mode 0, Mode 1, Mode 2, Mode 3 and Mode 4.

IDE Primary/Secondary Master/Slave UDMA:

Ultra DMA/33 implementation is possible only if your IDE hard drive supports it and the operating environment includes a DMA driver (Windows 95 OSR2 or a third-party IDE bus master driver). If your hard drive and your system software both support Ultra DMA/33, select "Auto" to enable BIOS support.

The choice: Auto, Disabled.

IDE HDD Block Mode:

Block mode is also called block transfer, multiple commands, or multiple sector read/write. If your IDE hard drive supports block mode (most new drives do), select Enabled for automatic detection of the optimal number of block read/writes per sector the drive can support.

The choice: Enabled, Disabled

Onboard Device:

Onboard Device		Item Help
USB Controller	Enabled	<hr/> Menu Level >
USB 2.0 Controller	Enabled	
USB Keyboard Support	Disabled	
USB Mouse Support	Disabled	
AC97 Audio	Auto	
Onboard LAN1 Device	Enabled	
Onboard LAN2 Device	Disabled	
Init Display First	Onboard/AGP.	
↑↓←→Move Enter: Select +/-PU/PD: Value F10: Save ESC: Exit F1: General Help F5: Previous Values F6: Fail-safe defaults F7: Optimized Defaults		

USB / USB 2.0 Controller:

Select "Enabled" if your system contains a Universal Serial Bus (USB) / USB 2.0 controller and you have USB peripherals.

The choice: Enabled, Disabled.

USB Keyboard Support:

Select "Enabled" if your system contains a Universal Serial Bus (USB) controller and you have a USB keyboard.

The choice: Enabled, Disabled.

USB Mouse Support:

Select "Enabled" if your system contains a Universal Serial Bus (USB) controller and you have a USB mouse.

The choice: Enabled, Disabled.

AC97 Audio:

This item allows you to decide to auto or disable the chipset family to support AC97 Audio.

The choice: Auto, Disabled.

Onboard LAN1/2 Device:

Select "Enabled" if your system has a LAN1/2 device installed on the system board and you wish to use it.

The choice: Enabled, Disabled.

Init Display First:

This item allows you to decide to active whether PCI slot or onchip VGA first.

The choice: PCI Slot, Onboard/AGP.

SuperI/O Device:

SuperI/O Device

SuperI/O Device		Item Help
POWER ON Function	BUTTON ONLY	
X KB POWER ON Password	Enter	
X Hot Key Power ON	Ctrl-F1	
Onboard FDC Controller	Enabled	Menu Level >
Onboard Serial Port 1	3F8/IRQ4	
Onboard Serial Port 2	2F8/IRQ3	
UART Mode Select	Normal	
X RxD, TxD Active	Hi, Lo	
X IR Transmission Delay	Enabled	
X UR2 Duplex Mode	Half	
X Use IR Pins	IR-Rx2Tx2	
Onboard Parallel Port	378/IRQ7	
Parallel Port Mode	SPP	
X EPP Mode Select	EPP1.7	
X ECP Mode Use DMA	3	
PWRON After PWR-Fail	Off	
↑↓←→Move Enter: Select +/-PU/PD: Value F10: Save ESC: Exit F1: General Help F5: Previous Values F6: Fail-safe defaults F7: Optimized Defaults		

Power On Function: Options Password, Hot KET, Any KEY, BUTTON and Keyboard 98.

You can use this item to select operating Power On the system.

KB Power ON Password: Option Enter

You can set password to limit operating KB Power On system.

Hot Key Power ON: Options Ctrl+F1 ~ Ctrl+F12

You can use this item to select operating Hot Key to Power On system.

Onboard FDC Controller:

Select "Enabled" if your system has a floppy disk controller (FDC) installed on the system board and you wish to use it. If you install and-in FDC or the system has no floppy drive, select Disabled in this field.

The choice: Enabled, Disabled.

Onboard Serial Port 1 / Port 2:

Select an address and corresponding interrupt for the first and second serial ports.

The choice: 3F8/IRQ4, 2E8/IRQ3, 3E8/IRQ4, 2F8/IRQ3, Disabled and Auto.

UART Mode Select:

This item allows you to select an operating mode for the second serial port.

The choice: IrDA, ASKIR and Normal.

RxD, TxD Active:

This item allows you to select the correct setting of receive and transmit signals from your IR port.

The Choice: "Hi, Hi", "Lo, Lo", "Lo, Hi" and "Hi, Lo".

IR Transmission Delay:

This item allows you to enable/disable IR transmission delay.

The choice: Enabled, Disabled.

UR2 Duplex Mode:

This item allows you to select the IR half / full duplex function.

The choice: Half, Full.

Use IR Pins:

This item allows you to select IR transmission routes, one is RxD2, TxD2 (COM Port) and the other is IR-Rx2Tx2.

The choice: IR-Rx2Tx2, RxD2 and TxD2.

Onboard Parallel Port:

This item allows you to determine access onboard parallel port controller with which I/O address.

The choice: 3BC/IRQ7, 378/IRQ7, 278/IRQ5 and Disabled.

Parallel Port Mode:

Select an operating mode for the onboard parallel (printer) port. Select Normal, Compatible, or SPP unless you are certain your hardware and software both support one of the other available modes.

The choice: SPP, EPP, ECP and ECP+EPP, Normal.

EPP Mode Select:

This item allows you to determine the IR transfer mode of onboard I/O chip.

The choice: EPP1.7, EPP1.9.

ECP Mode Use DMA:

This item allows you to select a DMA channel for the parallel port for use during ECP mode.

The choice: 3, 1.

PWRON After PWR-Fail: Options Off, Former-Sts.

This item allows you to select if you want to power on the system after power failure.

3.8 Power Management Setup

The Power Management Setup allows you to configure you system to most effectively save energy while operating in a manner consistent with your own style of computer use.

Phoenix - AwardBIOS CMOS Setup Utility
Power Management Setup

<p>Video Off Method DPMS</p> <p>Video Off In Suspend Yes</p> <p>Suspend Type Stop Grant</p> <p>Suspend Mode Disabled</p> <p>HDD Power Down Disabled</p> <p>Soft-off by PWR-BTTN Instant-Off</p> <p>CPU THER-Throttling 50.0%</p> <p>Wake-Up by PCI card Disabled</p> <p>Resume by Alarm Disabled</p> <p>X Date (of Month) Alarm 0</p> <p>X Time (hh : mm : ss) Alarm 0 : 0 : 0</p> <p>** Reload Global Timer Events **</p> <p>Primary IDE 0</p> <p>Primary IDE 1 Disabled</p> <p>Secondary IDE 0 Disabled</p> <p>Secondary IDE 1 Disabled</p> <p>FDD, COM, LPT Port Disabled</p> <p>PCI PIRQ [A-D]# Disabled</p>	<p>Item Help</p> <hr/> <p>Menu Level ➤</p>
<p>↑↓←→Move Enter: Select +/-/PU/PD: Value F10: Save ESC: Exit F1: General Help</p> <p>F5: Previous Values F6: Fail-safe defaults F7: Optimized Defaults</p>	

Video Off Method:

This determines the manner in which the monitor is blanked.

V/H SYNC+Blank:

This selection will cause the system to turn off the vertical and horizontal synchronization ports and write blanks to the video buffer.

Blank Screen:

This option only writes blanks to the video buffer.

DPMS:

Initial display power management signaling.

Video Off In Suspend:

This determines the manner in which the monitor is blanked.

The choice: Yes, No.

Suspend Type:

This determines the CPU status during power saving mode.

The choice: PwrOn Suspend, Stop Grant.

Suspend Mode:

When "Enabled" and after the set time of system inactivity. All devices except the CPU will be shut off.

The choice: Disabled, 1, 2, 4, 8, 12, 20, 30, 40 Min and 1Hour.

HDD Power Down:

When "Enabled" and after the set time of system inactivity, the hard disk drive will be powered down while all other devices remain active.

The choice: Disabled, 1~15Min.

Soft-Off by PWR-BTTN:

Pressing the power button for more than 4 seconds forces the system to enter the Soft-Off state when the system has "hung."

The choice: Delay 4 Sec, Instant-Off.

CPU THER-Throttling:

Select the CPU THRM-Throttling rate.

The choice: 12.5%, 25.0%, 37.5%, 50.0%, 62.5%, 75.0% and 87.5%.

Wake-Up by PCI Card: Options Enabled, Disabled.

An input signal from PME on the PCI card awakens the system from a soft off state.

Resume by Alarm: Options Enabled, Disabled.

When "Enabled", you can set the date and time at which the RTC (real-time clock) alarm awakens the system from Suspend mode.

PM Events:

PM events are I/O events whose occurrence can prevent the system from entering a power saving mode or can awaken the system from such a mode. In effect, the system remains alert for anything, which occurs to a device, which is configured as Enabled, even when the system is in a power down mode.

Primary IDE 0

Primary IDE 1

Secondary IDE 0

Secondary IDE 1

FDD, COM, LPT Port

PCI PIRQ [A-D] #

3.9 PnP/PCI Configurations

This section describes configuring the PCI bus system. PCI, or **Personal Computer Interconnect**, is a system, which allows I/O devices to operate at speeds nearing the speed the CPU itself uses when communicating with its own special components. This section covers some very technical items and it is strongly recommended that only experienced users should make any changes to the default settings.

Phoenix - AwardBIOS CMOS Setup Utility
PnP/PCI Configurations

Reset Configuration Data	Disabled	Item Help
Resources Controlled By X IRQ Resources	Auto (ESCD) Press Enter	Menu Level >
PCI/VGA Palette Snoop	Disabled	Default is Disabled. Select Enabled to reset Extended System Configuration Data (ESCD) when you exit Setup if you have installed a new add-on and the system reconfiguration has caused such a serious conflict that the OS cannot boot
↑↓←→Move Enter: Select +/-/PU/PD: Value F10: Save ESC: Exit F1: General Help F5: Previous Values F6: Fail-safe defaults F7: Optimized Defaults		

Reset Configuration Data:

Normally, you leave this field Disabled. Select Enabled to reset Extended System Configuration Data (ESCD) when you exit Setup if you have installed a new add-on and the system reconfiguration has caused such a serious conflict that the operating system cannot boot.

The choice: Enabled, Disabled.

Resource controlled by:

The Award Plug and Play BIOS has the capacity to automatically configure all of the boot and Plug and Play compatible devices. However, this capability means absolutely nothing unless you are using a Plug and Play operating system such as Windows®95. If you set this field to "Manual" choose specific resources by going into each of the sub menu that follows this field (a sub menu is preceded by a "➤").

The choice: Auto (ESCD), Manual.

IRQ Resources:

Phoenix - AwardBIOS CMOS Setup Utility

IRQ Resources

IRQ3 assigned to	PCI Device	Item Help <hr/> Menu Level ➤	
IRQ4 assigned to	PCI Device		
IRQ5 assigned to	PCI Device		
IRQ7 assigned to	PCI Device		
IRQ8 assigned to	PCI Device		
IRQ9 assigned to	PCI Device		
IRQ10 assigned to	PCI Device		
IRQ11 assigned to	PCI Device		
IRQ12 assigned to	PCI Device		
IRQ14 assigned to	PCI Device		
IRQ15 assigned to	PCI Device		
↑↓→←Move Enter: Select +/-/PU/PD: Value F10: Save ESC: Exit F1: General Help F5: Previous Values F6: Fail-safe defaults F7: Optimized Defaults			

IRQs:

When resources are controlled manually, assign each system interrupt a type, depending on the type of device using the interrupt.

PCI/VGA Palette Snoop:

This item is designed to overcome problems that can be caused by some nonstandard VGA cards. This board includes a built-in VGA system that does not require palette snooping so you must leave this item disabled.

The choice: Enabled, Disabled.

3.10 PC Health Status

Phoenix - AwardBIOS CMOS Setup Utility

PC Health Status

CPU Warning Temperature	Disabled	Item Help
SYS Temperature	34°C/93°F	
CPU Temperature	40°C/104°F	
CPU Fan Speed	5010RPM	Menu Level >
SYS Fan Speed	5213RPM	
VCC_2V5	2.48V	
VCORE	1.29V	
3.3V	3.28V	
+ 5 V	4.97V	
+12 V	12.03V	
-12V	-11.54V	
-5V	-5.20V	
VBAT (V)	3.02V	
5VSB (V)	4.92V	
Shutdown Temperature	Disabled	
↑↓←→Move Enter: Select +/-PU/PD: Value F10: Save ESC: Exit F1: General Help F5: Previous Values F6: Fail-safe defaults F7: Optimized Defaults		

CPU Warning Temperature:

This item will prevent CPU from overheating.

The choice: 50°C / 122°F~70°C / 158°F, Disabled.

SYS / CPU Temperature:

Show you the current system & CPU temperature.

CPU / SYS FAN Speed:

Show you the current CPU & system fan speed.

VCORE / VBAT (V):

Show you the voltage level of the CPU (Vcore) / Battery.

+3.3V / +5V / +12V / -12V / -5V:

Show you the voltage of +3.3V/+5V/+12V/-12V/-5V.

Shutdown Temperature:

This item allows you to set up the CPU shutdown Temperature. This item is only effective under Windows® 98 ACPI mode.

The choice: Disabled, 60°C / 140°F, 65°C / 149°F, 70°C / 158°F and 75°C / 167°F.

3.11 Frequency/Voltage Control

Phoenix - AwardBIOS CMOS Setup Utility
Frequency/Voltage Control

Auto Detect PCI CLK Spread Spectrum	Enabled Disabled Item Help <hr/> Menu Level >
↑↓←→Move Enter: Select +/-/PU/PD: Value F10: Save ESC: Exit F1: General Help F5: Previous Values F6: Fail-safe defaults F7: Optimized Defaults	

Auto Detect PCI CLK:

When “Enabled”, this item will auto detect if the PCI slot have devices and will send clock signal to PCI devices. When disabled, it will send the clock signal to PCI slot.

The choice: Enabled, Disabled.

Spread Spectrum:

When you enabled spread spectrum, it can significantly reduce the EMI (ElectroMagnetic Interference) generated by the system.

The choice: Disabled, Enabled.

3.12 Load Fail-Safe Defaults

When you press <Enter> on this item you get a confirmation dialog box with a message similar to:

Load Fail-Safe Defaults (Y/N)? **N**

Pressing 'Y' loads the BIOS default values for the most stable, minimal-performance system operations.

3.13 Load Optimized Defaults

When you press <Enter> on this item you get a confirmation dialog box with a message similar to:

Load Optimized Defaults (Y/N)? **N**

Pressing 'Y' loads the default values that are factory settings for optimal performance system operations.

3.14 Supervisor/User Password Setting

You can set either supervisor or user password, or both of them. The differences between are:

Set Supervisor Password: can enter and change the options of the setup menus.

Set User Password: just can only enter but do not have the right to change the options of the setup menus. When you select this function, the following message will appear at the center of the screen to assist you in creating a password.

ENTER PASSWORD:

Type the password, up to eight characters in length, and press <Enter>. The password typed now will clear any previously entered password from CMOS memory. You will be asked to confirm the password. Type the password again and press <Enter>. You may also press <Esc> to abort the selection and not enter a password.

To disable a password, just press <Enter> when you are prompted to enter the password. A message will confirm the password will be disabled. Once the password is disabled, the system will boot and you can enter Setup freely.

PASSWORD DISABLED.

When a password has been enabled, you will be prompted to enter it every time you try to enter Setup. This prevents an unauthorized person from changing any part of your system configuration.

Additionally, when a password is enabled, you can also require the BIOS to request a password every time your system is rebooted. This would prevent unauthorized use of your computer.

You determine when the password is required within the BIOS Features Setup Menu and its Security option (see Section 3). If the Security option is set to "System", the password will be required both at boot and at entry to Setup. If set to "Setup", prompting only occurs when trying to enter Setup.

3.15 Exit Selecting

Save & Exit Setup

Pressing <Enter> on this item asks for confirmation:

Save to CMOS and EXIT (Y/N)? Y

Pressing “Y” stores the selections made in the menus in CMOS – a special section of memory that stays on after you turn your system off. The next time you boot your computer, the BIOS configures your system according to the Setup selections stored in CMOS. After saving the values the system is restarted again.

Exit Without Saving

Pressing <Enter> on this item asks for confirmation:

Quit without saving (Y/N)? Y

This allows you to exit Setup without storing in CMOS any change. The previous selections remain in effect. This exits the Setup utility and restarts your computer.