

use & care guide

Electrical Requirements Page 3
Installation Instructions Page 4
How to Use Page 10

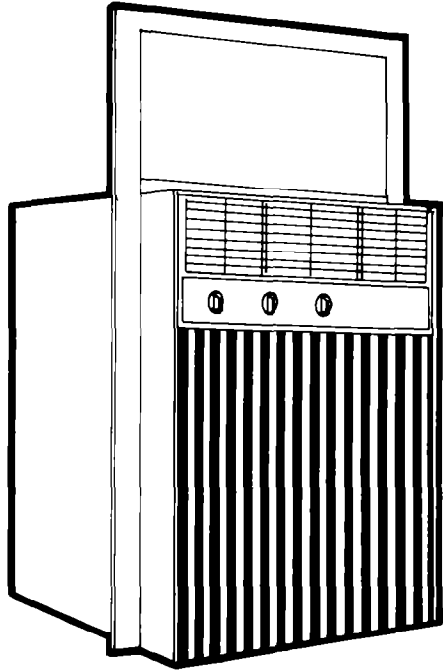

AIR CONDITIONER

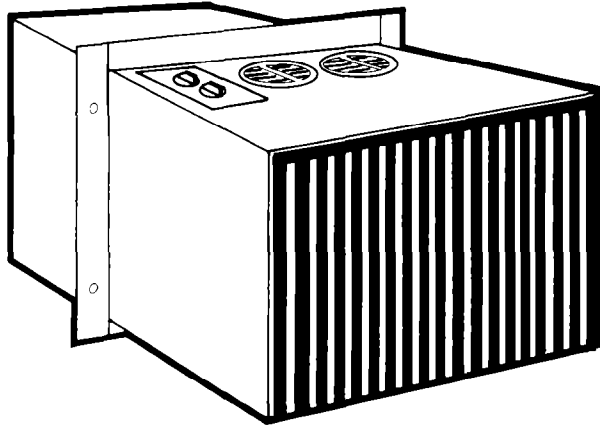

Ovens, Compactors, Room Air Conditioners, Dehumidifiers, Automatic Washers, Clothes Dryers, Freezers, Refrigerator-Freezers, Ice Makers, Dishwa

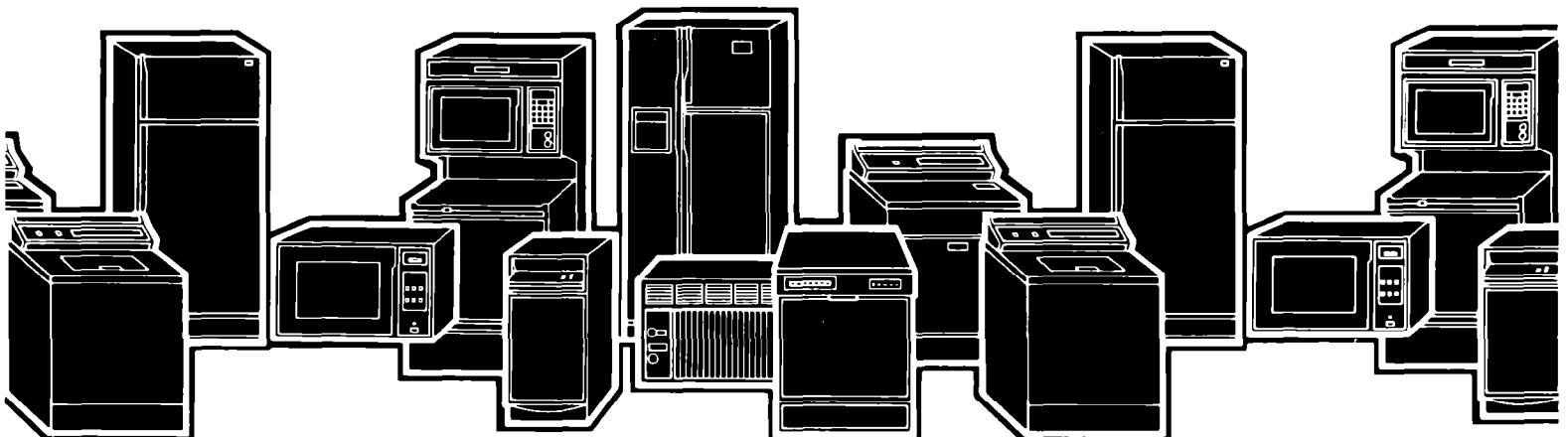

IMPORTANT...

Please read this use and care guide before installing or using your air conditioner. It tells you how to install and operate it, and gives important electrical information. Save it for future use in case you may have a question or move the air conditioner.

Copy your Model and Serial Numbers here...

When you need service or call with a question, have this information ready:

1. Complete Model and Serial Numbers (Model and Serial Numbers are on a plate attached to the front of the unit. You can see it after removing the plastic front panel.)
2. Purchase date from sales slip. Copy this information in these spaces. Keep this book, your warranty and sales slip together in a handy place. (To remove front panel, see page 11.)

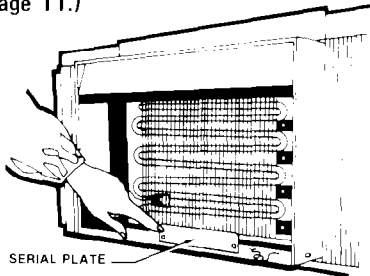

Model Number _____

Serial Number _____

Purchase Date _____

Service Company and Telephone Number _____



CAUTION:
Handle the air conditioner with care. Watch out for the sharp metal fins on the front and rear coils.

BEFORE YOU USE YOUR AIR CONDITIONER

It is your responsibility to make sure that your air conditioner:

- Has been properly installed.
- Is the right size for the area you want to cool.
- Is properly connected to electricity.
- Is properly electrically grounded.
- Is properly used only for the job it was intended to do.
- Is not used by children or anyone not able to operate it properly.
- Is properly maintained.
- Also, remove energy label and buy guide. Use damp cloth to take off any glue residue. Do not use a sharp instrument or any harsh or abrasive cleaners.

Energy Saving Tips

- Improve home insulation (seal doors, windows, and close fireplace flue).
- Close blinds or drapes on sunny side of house; add window awnings.
- Keep air filter clean. Don't block air flow with drapes or furniture.
- Ventilate attic (high temperature levels add to normal cooling load).
- Try not to use heat producing appliances during the hottest part of the day. Turn lights, radios, televisions, and other appliances off when not needed.
- Keep heat registers and cool air returns closed or blocked off so cooled air won't escape.
- Use a vent fan in areas where cooking, laundry, or bathing is done to pull out extra heat and moisture near its source.

Contents

	page		page
Before You Use Your Air Conditioner	2	Cleaning and Caring for Your	
Energy Tips	2	Air Conditioner	11
Electrical Requirements	3	Cooling Load Guide	14
Installation Instructions	4	Self-Service Checklist	15
How to Start and		Service Information	15
Use Your Air Conditioner	10		

© 1985 Whirlpool Corporation

Electrical Requirements For Your Air Conditioner

ELECTRICAL REQUIREMENTS ARE DIFFERENT FOR THE TWO MODELS SHOWN ON THE COVER, DEPENDING ON THE AMPERE RATING OF YOUR UNIT. THE NUMBER OF AMPERES IS PRINTED ON THE SERIAL PLATE, ATTACHED TO THE FRONT OF THE UNIT, BEHIND THE FRONT PANEL (SEE PAGE 2).

OBSERVE ALL LOCAL GOVERNING CODES AND ORDINANCES

Do not, under any circumstances, remove the power supply cord ground prong.

RECEPTACLE WIRING

RECEPTACLE WIRING should be at least as large as 14 gauge. Use copper wire only. It is the personal responsibility and obligation of the customer to provide proper and adequate receptacle wiring installed by a qualified electrician. OBSERVE NATIONAL ELECTRICAL CODE AND ALL LOCAL GOVERNING CODES AND ORDINANCES.

Electrical Requirements

A 115 volt (103.5 min., 126.5 max.) 60 hertz AC only, 15 ampere fused electrical supply is required (time delay fuse or time delay circuit breaker required). *It is recommended that a separate circuit, serving only this appliance, be provided for models with serial plate amperes up through 7.5. A separate circuit is required for models with serial plate amperes of 7.6 through 12.0. Do not use an extension cord.*

Electrical Connection

Electrical Ground is Required on this Appliance

RECOMMENDED GROUNDING METHOD

For your personal safety, this appliance must be grounded. This appliance is equipped with a power supply cord having a 3-prong grounding plug. To minimize possible shock hazard, the cord must be plugged into a mating 3-prong

grounding type wall receptacle, grounded in accordance with the National Electrical Code and local codes and ordinances. If a mating wall receptacle is not available, it is the personal responsibility and obligation of the customer to have a properly grounded 3-prong wall receptacle installed by a qualified electrician. See Figure 1.

Figure 1

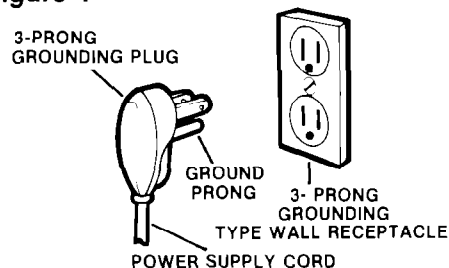

ALTERNATE GROUNDING METHOD

If changing and properly grounding the wall receptacle is impossible and where local codes permit (consult your electrical inspector), a temporary adapter may be plugged into the existing 2-prong wall receptacle to mate with the 3-prong power supply cord. See Figure 2. **THIS, HOWEVER, IS NOT RECOMMENDED.**

If this is done, you must connect the grounded eyelet on the adapter to the wall receptacle cover plate screw and from this same screw, you must connect a separate copper ground wire (#14 minimum) to a grounded cold water pipe.* See Figure 2. Do not ground to a gas supply pipe. Do not connect to electrical supply until appliance is permanently grounded.

Figure 2

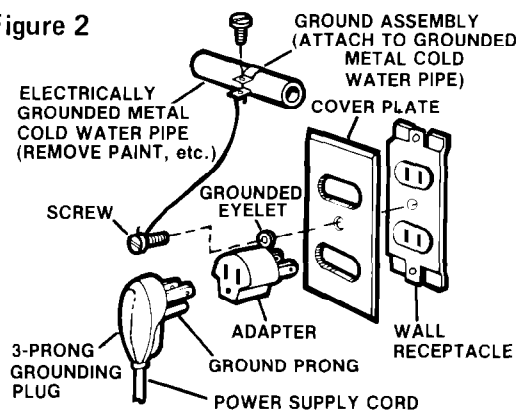

*Cold water pipe must have metal continuity to electrical ground and not be interrupted by plastic, rubber or other electrically insulating connectors (including water meter or pump) without adding a jumper wire at these connections.

INSTALLATION INSTRUCTIONS

for Your Air Conditioner

Unpack the mounting parts that came with your air conditioner to determine which window installation instruction you should follow.

If you have these parts, follow: **INSTRUCTION 1** (below).

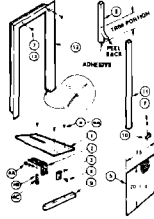

If you have these parts, follow: **INSTRUCTION 2** (on page 8).

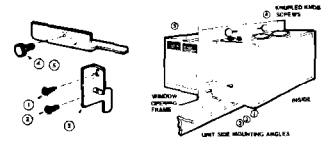

1 Installation Instructions

- To help avoid any installation problems and to help assure trouble-free performance of your new air conditioner, read these installation instructions, as well as the operating instructions and electrical requirements before installing your unit.
- Because this air conditioner weighs from approximately 90 to 105 pounds, it is recommended that you have somebody help you install your new unit and that you both use proper lifting techniques to avoid personal injury.
- Inspect the condition of the window where the air conditioner will be installed. Be sure it will support the weight of the unit.

CAUTION:

- Be sure air conditioner does not fall out of window during installation.
- Handle the air conditioner with care. Watch out for the sharp metal fins on the front and rear coils.
- Do not use the collected water for drinking purposes. It is not sanitary.



THIS APPLIANCE MUST BE INSTALLED ACCORDING TO ALL APPLICABLE CODES AND ORDINANCES

1. **Unpack mounting parts** before installing your air conditioner. Make sure you have all the necessary parts (see Figure 3). A normal installation can be made with a screwdriver, saw, small level, pocket knife, tape measure, drill and 1/8", 9/64" and 3/16" drill bits.

Figure 3

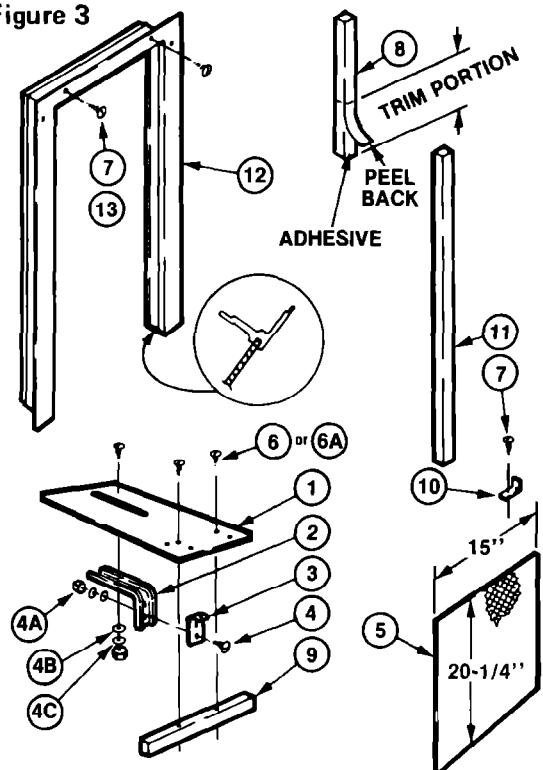

- | | |
|-----------------------------|---|
| 1 Shelf (1) | 6A Screw - 10 x 1 3/4 in. (2) |
| 2 Support Bracket (1) | 7 Screw - 8 x 3/4 in. (5) |
| 3 Sill Bracket (1) | 8 Side Seal Strip (1) |
| 4 5/16-in. bolt (2) | 9 Lower Track Seal (1) |
| 4A 5/16-in. nut (2) | 10 Locking Bracket (1) |
| 4B 5/16-in. flat washer (2) | 11 Foam Seal Strip (1) |
| 4C 5/16-in. lockwasher (2) | 12 Panel Frame (1) |
| 5 Translucent Panel (1) | 13 Thread Cutting Screw #8/32 x 3/4 in. (4) |
| 6 Screw - 10 x 1-in. (2) | |

Description of Parts

If using Item 13 for fastening Item 10 or 12 to metal or plastic, use 9/64-in. dia. or #28 drill.

2. Pick the right window. First, decide what room(s) you want to cool. Then choose a window that will allow the air-conditioned air to flow freely and directly into the room(s) you want cooled. Remember, it's difficult to move air around corners. If the inner sliding window slides to the left, the unit will be installed on the right. Remove window screen if there is one. Choose a sliding window that's also near an electrical outlet. (Refer to the ELECTRICAL REQUIREMENT page for type of receptacle and wiring needed.) **Do not use an extension cord.** The sliding window in which you place your air conditioner should have an opening of at least 15-1/2" wide and 21-1/4" to 40-7/8" high (see Figure 4). For installations up to 62-1/4" high, a special kit (Part No. 977449) is available. For windows as low as 20-7/16", you must install without filler frame and remove top angle on unit, reinstalling 3 screws into top of cabinet.

This model may also be installed in steel hinged casement windows. The steel hinged casement window must have an opening at 15-1/2" wide and no more than 16-1/2" wide.

Figure 4

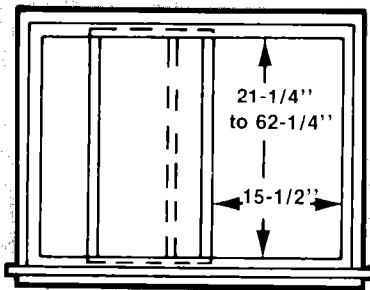

3. Place shelf in window with tabs against the track surface (see Figure 5).

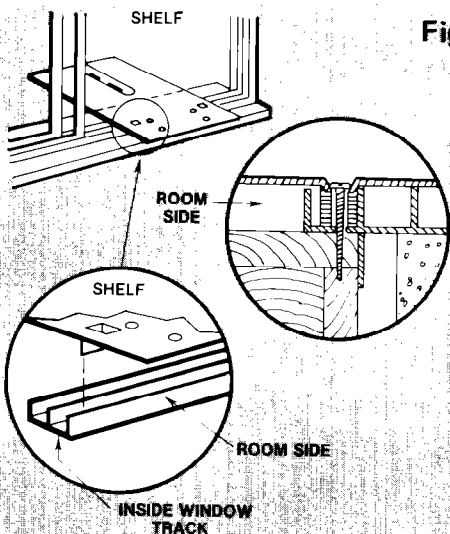
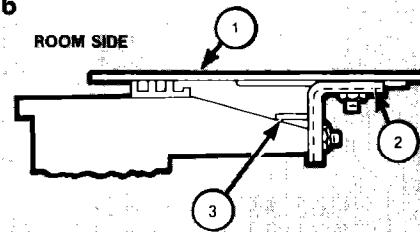

Figure 5

4. Install support bracket (Item 2) with either short or long leg down and with end of bracket either toward or away from window, depending upon construction and depth of wall and window sill (see Figure 6). Install sill bracket (Item 3). Each bracket is attached using one 5/16" bolt, nut and washers (Items 4, 4A, 4B and 4C).

Figure 6



5. Reinstall assembled shelf with two brackets into the window opening. Adjust brackets until shelf is firmly seated and sloping down to outside. If you use a level, be sure you have 1/2 bubble of slope. Without a level, place the translucent panel (Item 5) on shelf. The top of long side of the panel will be 5/16" back from the window line (see Figure 7).

Figure 7

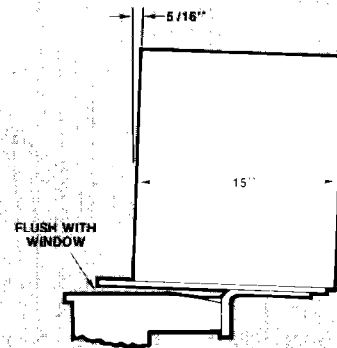

6. If slope back is correct, tighten all nuts securely. Install lower track seal (Item 4) shown in Figure 8. This track seal has two holes which line up with matching screw holes in shelf.

Figure 8

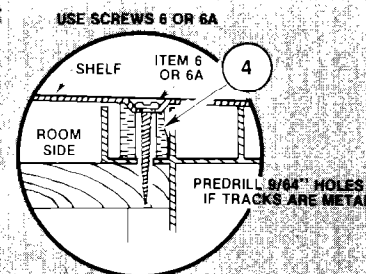

7. Install shelf 2-3/8" from side of window opening (see Figure 9).
8. Measure height of opening (see Figure 9). Subtract 20-9/16" from measured height. This will be the actual height of translucent panel.

Figure 9

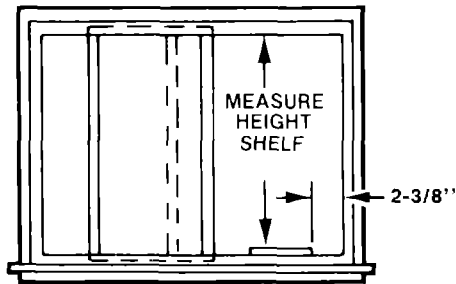

9. Measure out the distance from Figure 9 and mark it along the 20-1/4" side of translucent panel. Clamp panel between a board and an appropriate supporting surface close to mark and cut with fine tooth saw (see Figure 10.) Remove burrs.

Figure 10

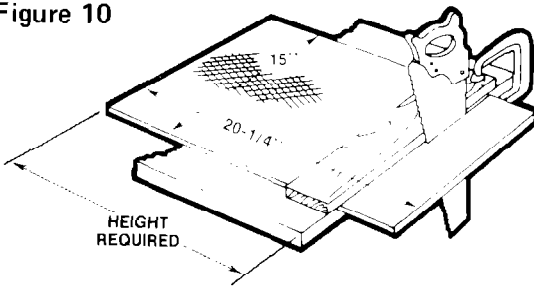

10. Lift vertically and remove panel frame from unit. Slide translucent panel into groove in frame, keeping honeycomb side to the face side of frame (see Figure 11). Slide frame back into place on unit. Panel should enter the top angle groove.

Figure 11

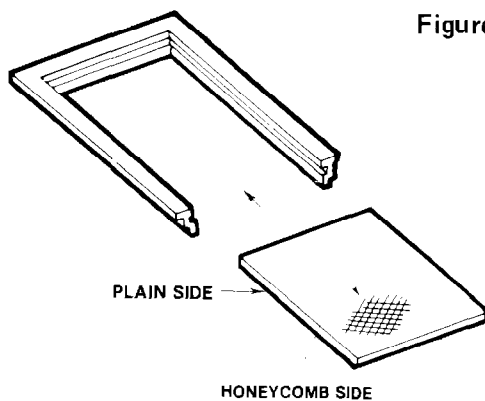

11. Peel backing from seal strip (Item 8) and press it onto side filler frame guides on each side of unit (see Figure 12).

Figure 12

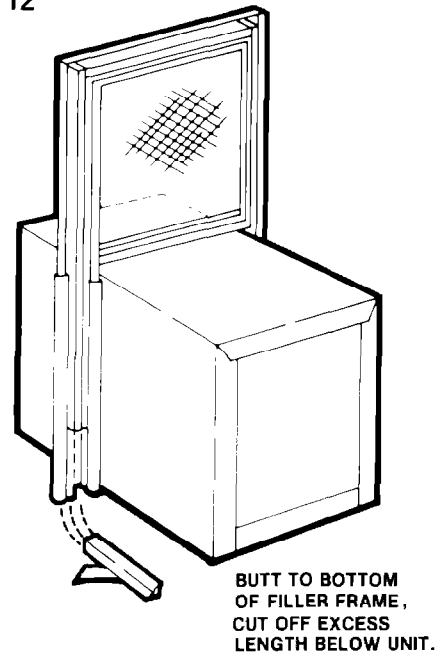

12. Place unit in window by resting unit on shelf. Push unit towards window so side angles are sealing against the side jamb stop (see Figure 13). Slide the opened window sash firmly to side of unit. Push unit and filler frame to make certain the frame and unit sealing strips are sealing.

Figure 13

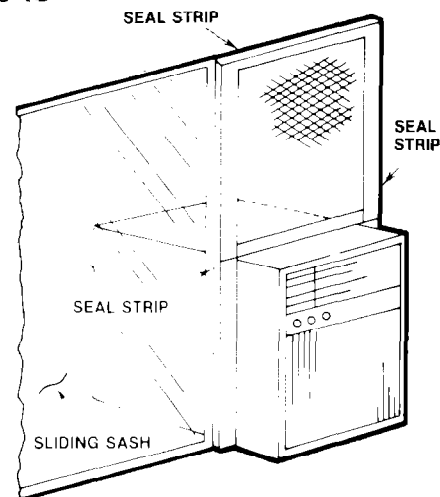

- 13.** Using 1/8" drill, install locking screws (Item 7). Use two screws in top jamb and in the side bottom flanges (see Figure 14). If you need additional holding strength, add two more screws at upper sides of filler frame (marked "A"). Also, two screws can be added at unit sides (marked "B"). However, if you add screws at "B", you must use a 3/16" drill bit to predrill through the plastic sides of air conditioner.

Figure 14

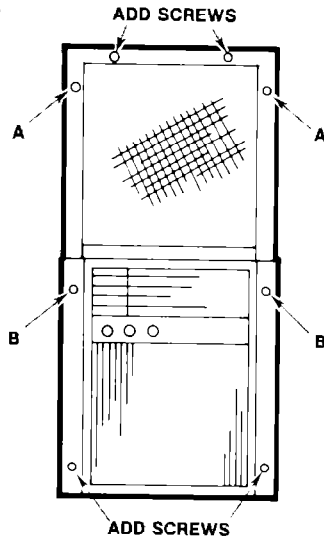

- 14.** Lock the sliding sash at bottom using lock bracket (Item 10) and screw (Item 7) as shown in Figure 15. Use a 1/8" drill bit to drill through track before inserting screw.

Figure 15

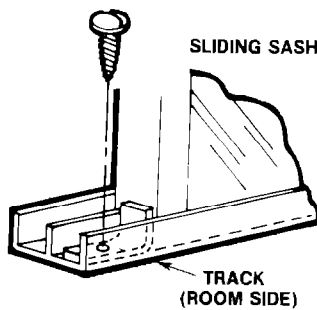

- 15.** Cut seal strip (Item 11) to length. Install it between space of opened sash and glass of the closed sash (see Figure 16).

Figure 16

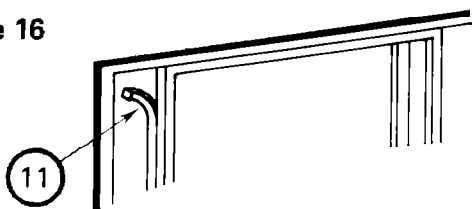

- 16.** FOR INSTALLATION IN SLIDING WINDOWS THAT DO NOT HAVE SIDE OR TOP TRACK.

The top flanges and one side flange of the air conditioner must butt up to a flange on the window. These window flanges must not be more than 1/16" thick. On the side with the open sash, the leading edge of the sash becomes the flange. The flange is on the top and jamb side of most metal windows. Use a metal angle or add wood to provide a flange for the unit in windows where there is no side jamb stop, or where there is a thick wood jamb stop. Follow the three suggestions shown in Figure 17.

Figure 17

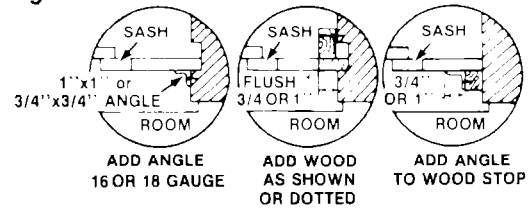

- 17.** FOR INSTALLATION IN STEEL CASEMENT WINDOWS.

Follow Steps 2 and 3 on page 5. NOTE: in Step 3, the shelf tabs must butt to the front of the bottom angle on the casement (see Figure 18).

Figure 18

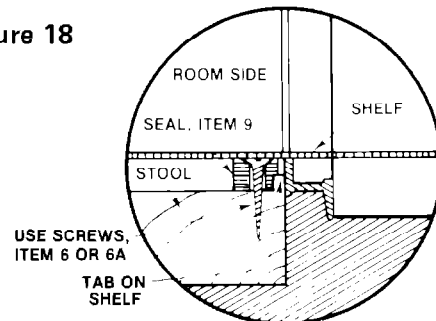

- 18.** When Step 3 is finished, follow Steps 4, 5, and 6 on page 5; Steps 7, 8, 9, 10, 11 and 12 on page 6. Then follow Steps 19 and 20 on page 7 and 8.

- 19.** Open window at least 180° to allow room for unit cabinet. If necessary, remove window crank handle so the window will open wide enough and not interfere with shelf against the bottom sill angle. Tie opened window to the wall or frame to prevent the window from swinging.

Figure 19

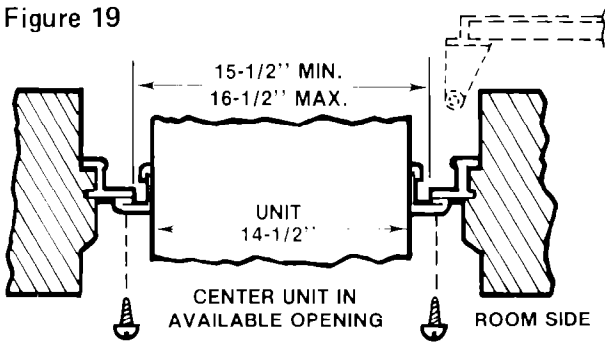

THIS APPLIANCE MUST BE INSTALLED ACCORDING TO ALL APPLICABLE CODES AND ORDINANCES

1. **Unpack mounting parts** before installing your air conditioner. Be sure you have all the necessary parts (see Figure 20 and 21). This air conditioner will fit most steel casement windows. A normal installation can be made with a screwdriver, $\frac{5}{16}$ " socket driver, tape measure and drill.

20. Drill $\frac{9}{64}$ " holes in the window jamb top to line up with holes in filler frame (see Figure 19). Use two thread cutting screws (Item 13) to secure unit. If you need additional holding strength, add to screws at the bottom of the unit side channels (see Figure 14 on page 7).

2 Installation Instructions

- To help avoid any installation problems and to help assure trouble-free performance of your new air conditioner, read these installation instructions, as well as the operating instructions and electrical requirements before installing your unit.
- Because this air conditioner weighs from approximately 70 to 75 pounds, it is recommended that you have somebody help you install your new unit and that you both use proper lifting techniques to avoid personal injury.
- Inspect the condition of the window where the air conditioner will be installed. Be sure it will support the weight of the unit.

CAUTION:

- Be sure air conditioner does not fall out of window during installation.
- Handle the air conditioner with care. Watch out for the sharp metal fins on the front and rear coils.
- Do not use the collected water for drinking purposes. It is not sanitary.

Figure 20

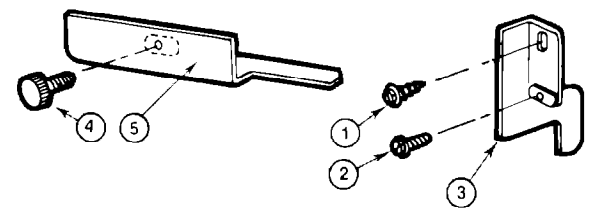
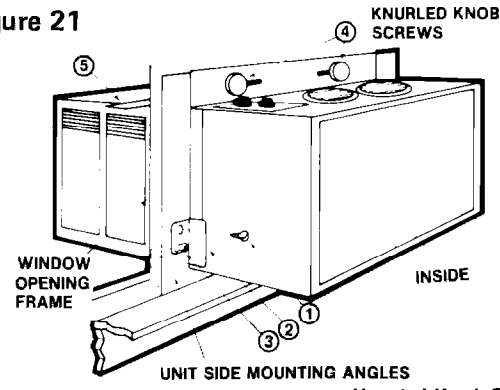

Figure 21



1. #10 x 3/8" Long S.M. Screw
2. #10-32 x 3/8" Long Mach. Screw
3. Bottom Mounting Bracket
4. Knurled Knob Screw
5. Top Mounting Bracket

NOTE: Above Parts (Not Shipped Loose) installed on unit by factory.

2. Pick the right window. First, decide what room(s) you want to cool. Then choose a window that will allow the air-conditioned air to flow freely and directly into the room(s) you want cooled. Remember, it's difficult to move air around corners. Choose a window that's also near an electrical outlet. (Refer to the ELECTRICAL REQUIREMENT page for type of receptacle and wiring needed.) **Do not use an extension cord.** To be able to use the window mounting parts shown in Figure 20, the window should have a minimum width of 14-1/2" and maximum width of 16" (see "A" in Figure 22). The window should have a minimum height of 10-5/8" and maximum height of 11-1/4" (see "B" in Figure 22).

Figure 22

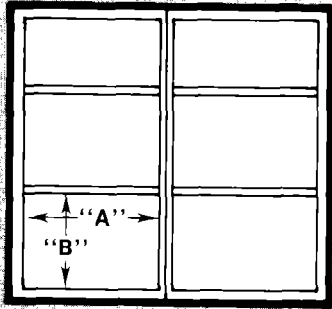

3. Remove the glass from the frame opening selected. Clear away any hardened putty.
4. Before sliding unit through the casement opening, remove the bottom window bracket (Item 3) on both sides of the unit. **NOTE:** only the top screws (Item 1) need to be removed.
5. Check the knurled knob screws to see that the top mounting brackets (Item 5) are retracted to the center of the unit. They must not interfere with the window frame when the unit is installed (see Figure 23).

Figure 23

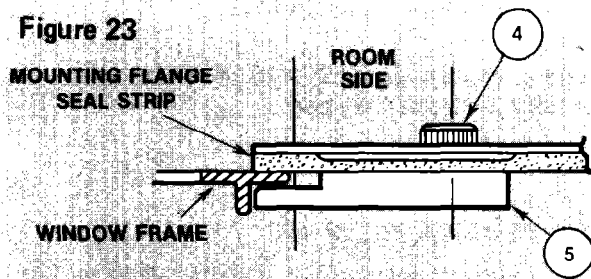

6. Lift the unit into the window opening and slide it back until the mounting frame comes into contact with the window frame (see Figure 24).

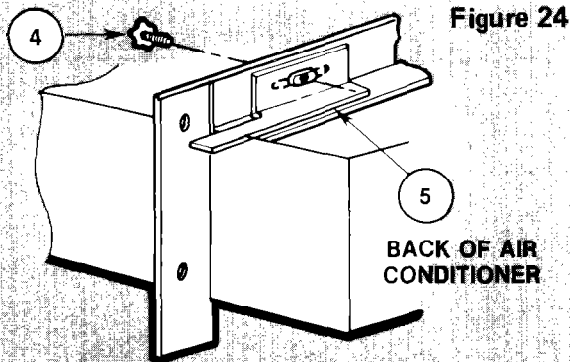
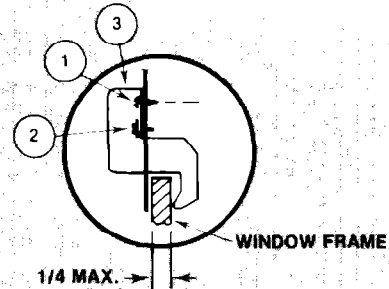

Figure 24

them loose enough so there is about 1/16" of play. Tighten the bottom screws (Item 2). This will pull the unit mounting flange tightly to the window frame, sealing and locking the air conditioner in place.

Figure 25



8. Loosen the two knurled knob screws and slide the top mounting bracket (Item 5) toward the outside of the unit, engaging the window frame (see Figure 26). Tighten the knurled knob screw in this position. This will lock the unit in place so it cannot tilt into the room. The installation is now complete.

Figure 26

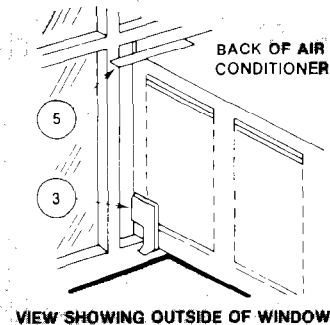

9. OPTIONAL MOUNTING INSTRUCTIONS

If the window thickness will not allow you to use the four mounting brackets provided with the unit, remove brackets and fasten flanges of unit with sheet metal screws (see Figure 27). These screws are not provided. The window opening for your installation must not be wider than 15".

Figure 27

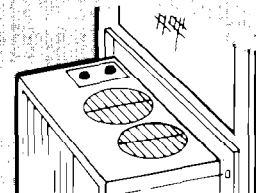

HOW TO START AND USE YOUR AIR CONDITIONER

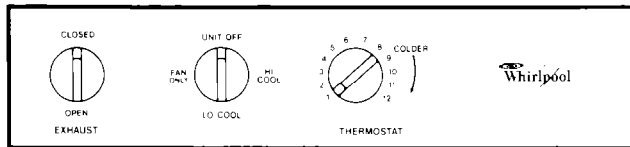

EXHAUST CONTROL FAN SPEED CONTROL THERMOSTAT CONTROL

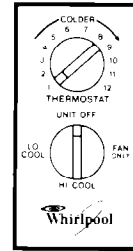

THERMOSTAT CONTROL
FAN SPEED CONTROL

Be sure air conditioner is OFF before plugging it in.

To Start Your Air Conditioner

1. Set exhaust control (if your unit is so equipped) to CLOSED for maximum cooling.
2. Choose either LO COOL or HI COOL fan speed setting.
 LO COOL for sleeping comfort
 HI COOL for maximum cooling
 FAN ONLY . . . for circulating room air when no cooling is desired

CAUTION:
 If you turn your air conditioner off, wait at least two minutes before turning it back on or you may blow a fuse.

The Exhaust Control

The Exhaust Control setting draws stale or smoky air from the room.

1. To exhaust room air

Set exhaust control to OPEN. Adjust fan control to speed desired. If no cooling is desired, use FAN ONLY setting.

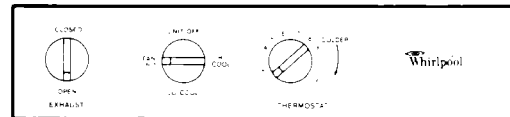

OPEN FAN ONLY

3. Turn the thermostat control to number 6 (mid-setting). You can adjust the air conditioner's cooling performance by resetting the thermostat control to a higher number for maximum cooling. Lower the number setting for less cooling. You will need to experiment to find the setting which suits you best.

2. To circulate room air

Set exhaust control to CLOSED. Adjust fan control to FAN ONLY.

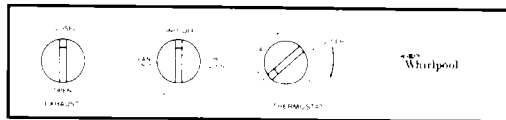

CLOSED FAN ONLY

Changing Air Direction

The louvers in the grille area at the top of the air conditioner control the direction of the cooled air.

1. If your unit looks like Figure 28, move the lever at top of the grille to the right, left or straight ahead. Simply move the lever in the direction you want the air to go. The rear vertical louvers in the grille can be adjusted left or right or straight ahead. The front set is fixed and directed upward.

Figure 28

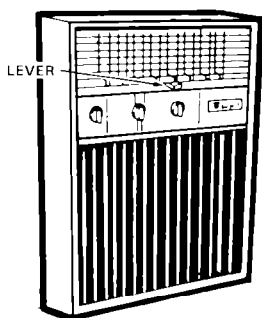
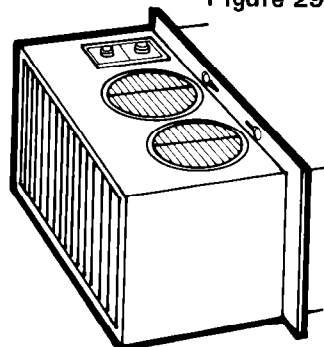

Figure 29



2. If your unit looks like Figure 29, turn the circular air discharge grilles on top of the unit. Both grilles can be adjusted to the right or left, or adjusted individually.

Cleaning and Caring for Your Air Conditioner

Proper use and care of your air conditioner will help insure longer life and lower operating costs. Follow these instructions carefully. Call your dealer for an annual checkup.

Cleaning of Front Panel



WARNING: DISCONNECT FROM ELECTRICAL SUPPLY BEFORE CLEANING UNIT.

1. Remove the front panel from unit when cleaning. Press down at top edge of the front as shown in Figure 30 or 31 (depending on your model).
2. When the front moves away from top of cabinet, pull top of front toward you.
3. Lift up and away from the bottom spring clips.

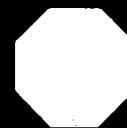

CAUTION:

Do not use cleaning fluids, solvents, abrasive cleaners, or strong detergents. They may damage the parts.

Figure 30

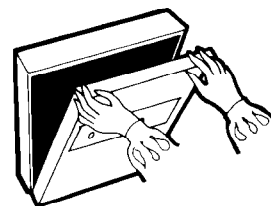
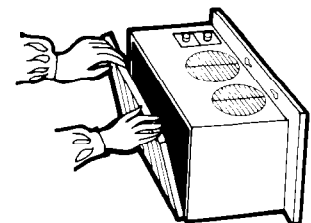

Figure 31



4. Clean front panel with warm water and mild soap or detergent. Use a soft cloth. Rinse and dry. Replace front panel.
5. Wipe control panel clean with a soft dry cloth.

Cleaning Air Conditioner Filter

The filter is cleanable. A clean filter helps remove dust, lint and other particles from the air. Check every two weeks to see if filter needs cleaning.

1. Remove filter by releasing it from plastic clips as shown in Figure 32 or 33 (depending on your model).
2. Clean filter, using a vacuum cleaner.
— OR —
3. If very dirty, wash filter with warm water and mild detergent. Air dry thoroughly before replacing.

Figure 32

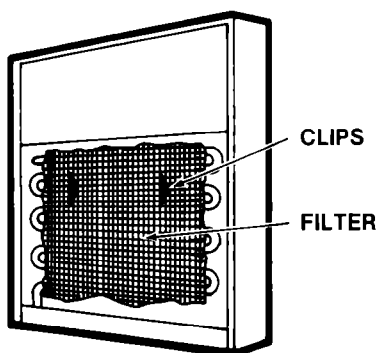
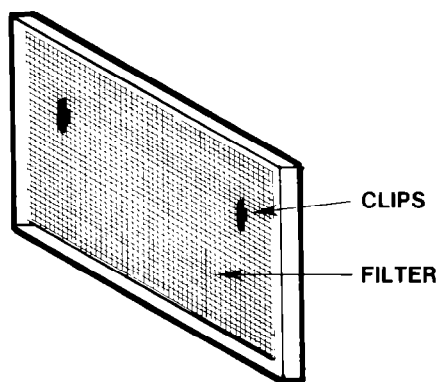

Figure 33



Annual Maintenance for Your Air Conditioner

Your air conditioner needs annual maintenance to help insure steady, top performance throughout the year.

Call the service company recommended by your dealer to:

- Inspect and clean the coils and condensate water passages.
- Check fan and oil the fan motor.
- The compressor is sealed and needs no oiling.

Expense of annual inspection is customer's responsibility.

— or —

If you are familiar with electrical appliances, you can do the cleaning and maintenance yourself. If you decide to go ahead, follow these steps:

WARNING:



- SHOCK OR INJURY HAZARD -
Before performing any maintenance, be sure to disconnect power cord from receptacle.

CAUTION:



Be sure no liquid gets into the motor, electrical control box or compressor electrical terminals.

1. **REMOVE UNIT FROM CABINET.** Wrap the motor, electrical control box and electrical terminals box in plastic film and make sure no water or other liquid gets inside any of these parts. It could damage the insulation and cause serious trouble.
2. Carefully clean and hose out the base, coils and condensate pans. Clean at least once a year or more often if the condenser coils and pans collect dirt, sand, leaves, insects or algae. Also, clean if you detect an odor from the air conditioner. While the cabinet is open, this is a good time to oil the fan motor.
3. Remove plastic film from motor and electrical parts.
4. Replace unit in cabinet.

NOTE: It's a good idea to wait 24 hours before starting the unit again. This allows time for all areas to dry out. The water from rainfall or from normal operation does not harm these components.

Oiling of the Fan Motor



WARNING:

- SHOCK OR INJURY HAZARD -
Before performing any maintenance, be sure to disconnect power cord from receptacle.

1. Oil the fan motor per instructions on the motor. To add oil, pull out the oil hole plug at each end of the motor. (see Figure 34).

Figure 34

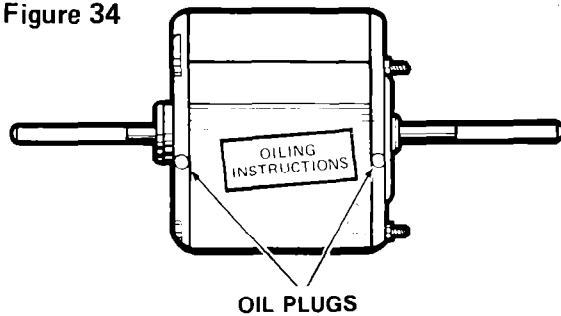

An easy to use one-ounce capsule of especially recommended oil (Part No. 10943) can be ordered from your dealer.

2. Replace the plug to keep dirt from motor bearings.
3. Reinstall the unit in cabinet after performing maintenance. (See Installation Instructions.)

Notes:

COOLING LOAD GUIDE—SQUARE FEET METHOD

ROOM AIR CONDITIONERS

To make sure you choose the right size unit, use this "COOLING LOAD GUIDE — SQUARE FEET METHOD." It is a quick, easy means of computing capacity.

For extremes in exposure, shading, insulation and building construction, AHAM Cooling Load Estimate Form RAC-1 must be used

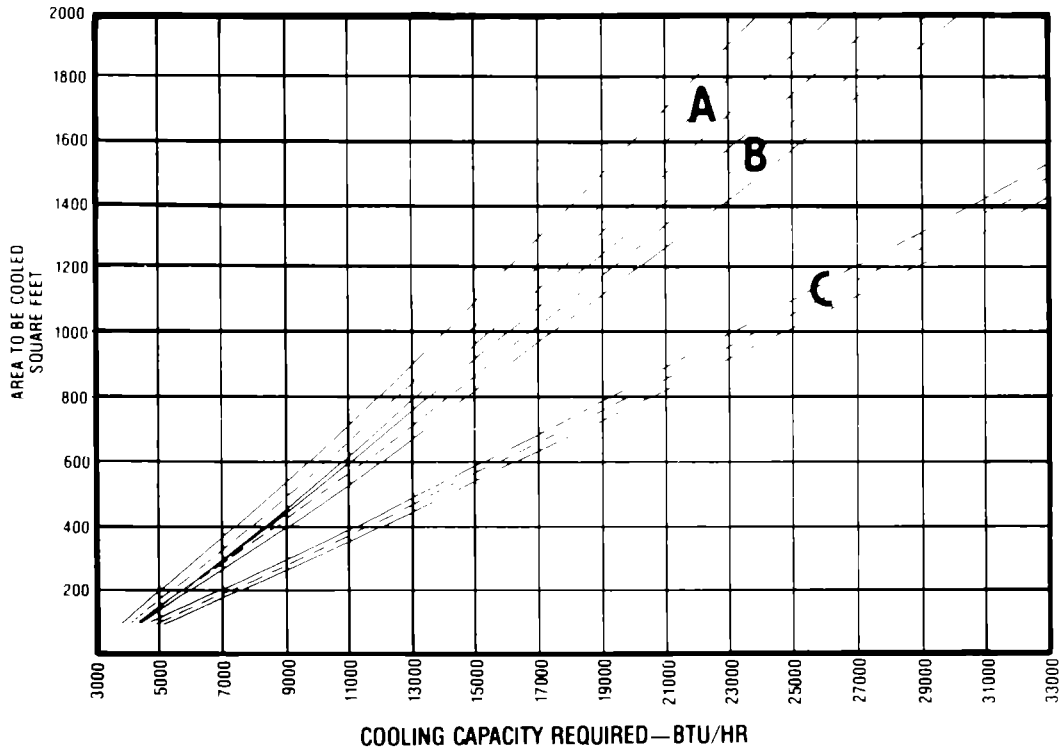

INSTRUCTIONS:

1. Determine the area to be cooled in square feet and locate that point on the left side of chart.
2. Move horizontally across to the center line of Band A, B or C according to the condition of the ceiling in the area to be cooled.
Band A—Occupied Space Above Ceiling
Band B—Insulated Ceiling Under Attic
Band C—Non-Insulated Ceiling Under Attic
3. From center of band move within the band to left for more northerly exposure or right for more westerly exposure.
4. From this point, read down to bottom of chart to determine required Btu/hr output. Write the Btu/hr figure in the space indicated below.

5. _____ Btu/hr (from number 4 above).

6. _____ Locate your geographic area on inset map and multiply factor shown by figure in number 5.

7. _____ If room air conditioner is intended primarily for night-time cooling, subtract 30% (from figure in number 6)

8. _____ Subtract 30 Btu/hr from figure in number 7 (or 6) for each linear foot of wall separating the area to be cooled from another cooled room.

9. _____ If more than two people occupy area, add 600 Btu/hr per person (to figure in number 8); if only one person, subtract 600 Btu/hr.

10. _____ Add 4000 Btu/hr (to figure in number 9) if area to be cooled includes kitchen.

For best results, a room conditioning unit or units with a cooling capacity rating close to that estimated above should be selected.

A smaller capacity unit operating continuously will contribute more to comfort than a larger capacity unit operating intermittently.

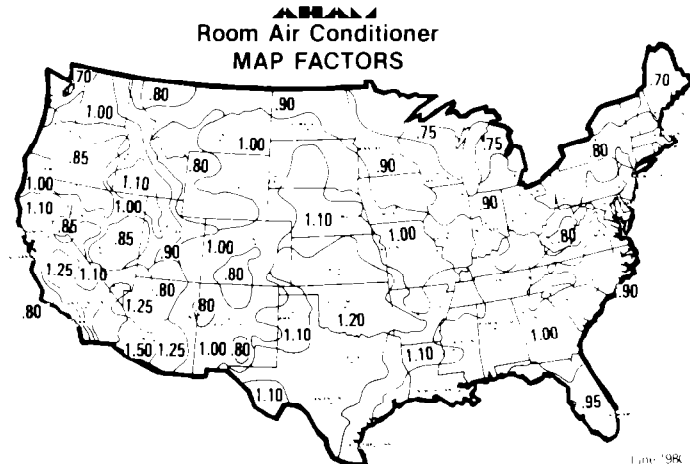

Line 98K

If you need service or assistance, we suggest you follow these four steps:

1. Before calling for assistance

Performance problems often result from little things you can find and fix yourself without tools of any kind.

Unit won't run:

1. Is unit plugged in?
2. Is switch ON?
3. Is thermostat set too WARM?
4. Is time-delay fuse blown?
5. Has local power failed?

Unit blows fuses:

1. Are time-delay fuses used?
2. Is an extension cord being used? (Do not use.)
3. Are you waiting two minutes after turning cooling circuit off before trying to restart unit?

Unit turns on and off, or does not cool room:

1. Is filter clean?
2. Are coils clean? Both evaporator (inside) and condenser (outside)?
3. Is there excessive moisture or heat? (Open vessel cooking, showers, etc.)
4. Set fan to higher speed.
5. Set thermostat to a cooler setting.

Operating sounds:

1. When your room air conditioner is **operating normally**, you will hear sounds such as:
 - Droplets of water hitting the condenser, causing a "pinging" or "clicking" sound. Water droplets help to cool the condenser.
 - Air movement from the fan, especially on high fan speed setting.
 - Clicks from thermostat cycle.
2. Sounds also may be caused by house construction -- such as vibration of the unit due to wall construction or unsteady window mounting area.

2. If you need assistance

Call the Whirlpool COOL-LINE® service assistance telephone number. Dial free from:

Continental U.S. (800) 253-1301
 Michigan (800) 632-2243
 Alaska & Hawaii (800) 253-1121

and talk with one of our trained Consultants. The Consultant can instruct you in how to obtain satisfactory operation from your appliance or, if service is necessary, recommend a qualified service company in your area.

3. If you need service



Whirlpool has a nationwide net work of franchised TECH-CARE® service Companies. TECH-CARE service technicians are trained to fulfill the product warranty and provide after-warranty service,

anywhere in the United States. To locate TECH-CARE service in your area, call our COOL-LINE service assistance telephone number (see Step 2) or look in your telephone directory Yellow Pages under:

APPLIANCES—HOUSEHOLD— MAJOR—SERVICE & REPAIR

WHIRLPOOL APPLIANCES
FRANCHISED TECH-CARE SERVICE
SERVICE COMPANIES
XYZ SERVICE CO
123 Maple

OR

ELECTRICAL APPLIANCES— MAJOR—REPAIRING & PARTS

WHIRLPOOL APPLIANCES
FRANCHISED TECH-CARE SERVICE
SERVICE COMPANIES
XYZ SERVICE CO
123 Maple

999-9999

999-9999

OR

WASHING MACHINES, DRYERS & IRONERS—SERVICING

WHIRLPOOL APPLIANCES
FRANCHISED TECH-CARE SERVICE
SERVICE COMPANIES
XYZ SERVICE CO
123 Maple

999-9999

4. If you have a problem

Call our COOL-LINE service assistance telephone number (see Step 2) and talk with one of our Consultants, or if you prefer, write to:

Mr. Robert Stanley
 Division Vice President
 Whirlpool Corporation
 2000 US-33 North
 Benton Harbor, MI 49022

If you must call or write, please provide: model number, serial number, date of purchase, and a complete description of the problem. This information is needed in order to better respond to your request for assistance.



FSP is a registered trademark of Whirlpool Corporation for quality parts. Look for this symbol of quality whenever you need a replacement part for your Whirlpool appliance FSP® replacement parts

will fit right and work right because they are made to the same exacting specifications used to build every new Whirlpool appliance



Part No. 203873/950491 Rev. A

© 1985 Whirlpool Corporation

Printed in U.S.A.

lifiers, Automatic Washers, Clothes Dryers, Freezers, Refrigerator-Freezers, Ice Makers, Dishwashers, Built-In Ovens and Surface Units, Ranges, Micr

