

ZANUSSI

ELECTRIC OVENS
FOURS ÉLECTRIQUES
ELEKTRO-BACKÖFEN
MEER-SYSTEMEN INBOUW-
FORNUIZEN
HORNOS ELÉCTRICOS
FORNOS ELÉCTRICO
ΗΛΕΚΤΡΙΚΟΣ ΦΟΥΡΝΟΣ
BMS 641 - BST 6

INSTRUCTION BOOKLET - NOTICE D'UTILISATION
GEBRAUCHSANWEISUNG - GEBRUIKSAANWIJZING
MANUAL DE INSTRUCCIONES - INSTRUÇÕES DE UTILIZAÇÃO
ΟΔΗΓΙΕΣ ΧΡΗΣΗΣ

Description of the appliance - Description de l'appareil
Gerätebeschreibung - Beschrijving van het toetsel
Descripción del horno - Descrição forno
Περιγραφή του φούρνου

Mod. BMS 641 W/N/Y/A - BST 6

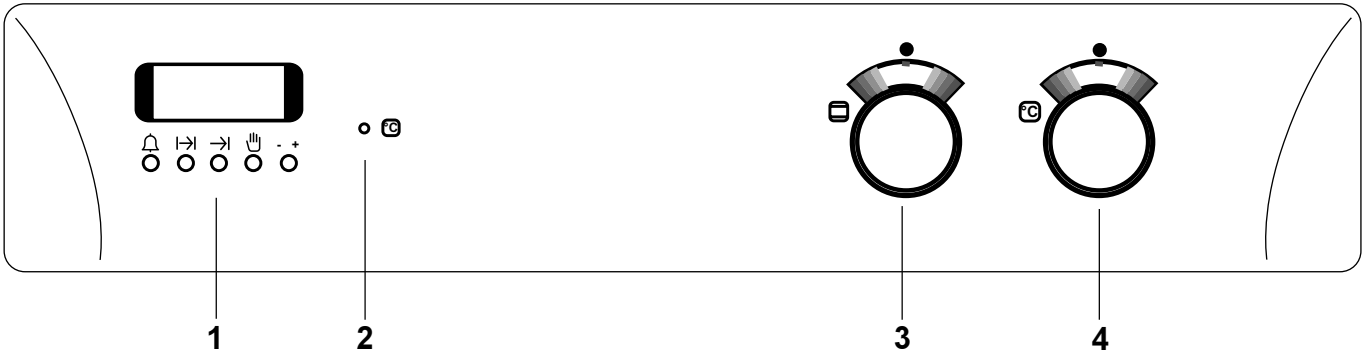

Mod. BMS 641 X

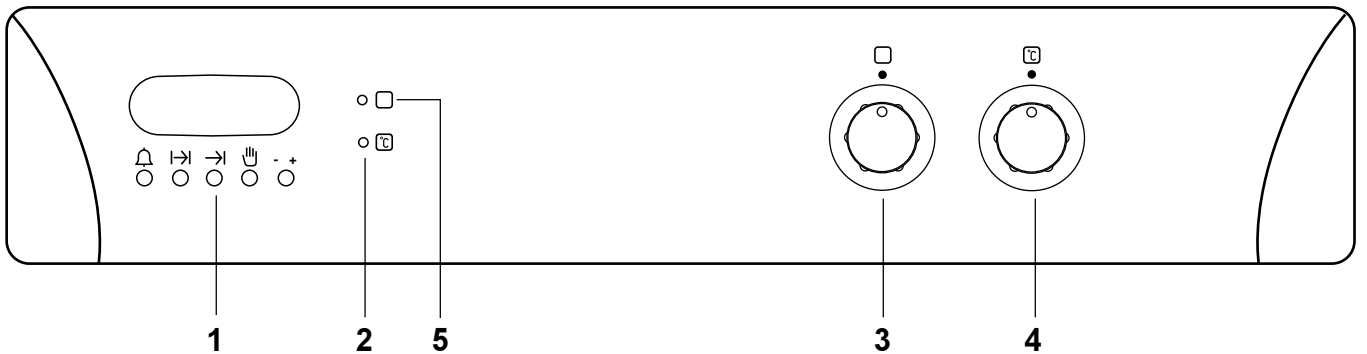

Control panel:

1. Electronic programmer
2. Oven Thermostat control light
3. Oven function control knob
4. Thermostat control knob
5. Oven function control light

Bandeau de commande:

1. Programmateur électronique
2. Lampe témoin thermostat four
3. Bouton sélecteur (fonctions)
4. Bouton thermostat (températures)
5. Lampe témoin générale

Bedienungsblende:

1. Elektronikuhr
2. Backofentemperaturanzeige
3. Backofenfunktionsschalter
4. Temperaturwähler
5. Betriebskontrollampe

Bedieningspaneel:

1. Elektronische Programmaklok
2. Thermostaatlampje
3. Functieknop
4. Thermostaatknop
5. Controlelampje "Oven in bedrijf"

Panel de mandos:

1. Programador electrónico
2. Piloto temperatura horno
3. Mando control horno
4. Mando control termostato
5. Piloto indicador de encendido general

Painel de comandos:

1. Programador electrónico
2. Indicador luminoso do termostato
3. Selector das funções do forno
4. Selector do termostato do forno
5. Indicador luminoso general

Πίνακας ελέγχου:

1. Ηλεκτρονικός προγραμματιστής
2. Ενδεικτική λυχνία θερμοστάτη (C)
3. Διακόπτες ελέγχου λειτουργίας του φούρνου
4. Διακόπτης ελέγχου του θερμοστάτη
5. Ενδεικτική λυχνία φούρνου

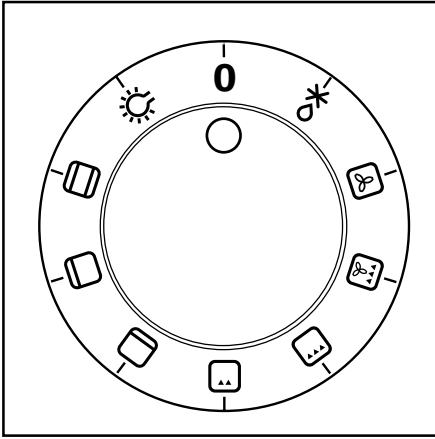

Fig. 1

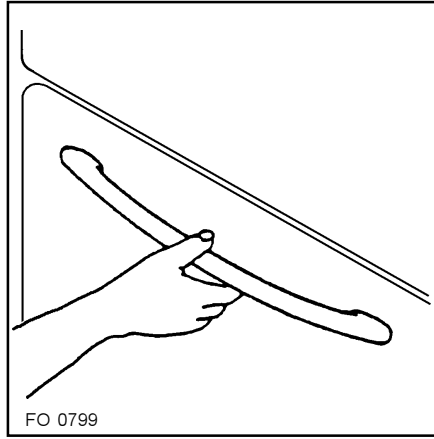

Fig. 5

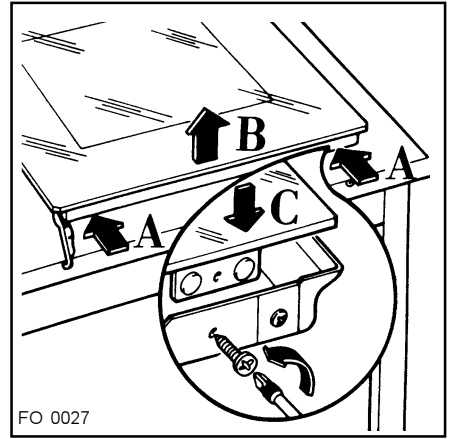

Fig. 9

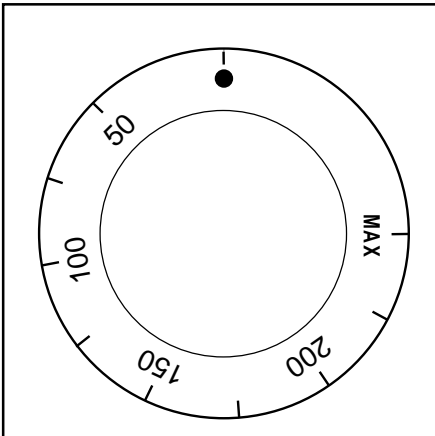

Fig. 2

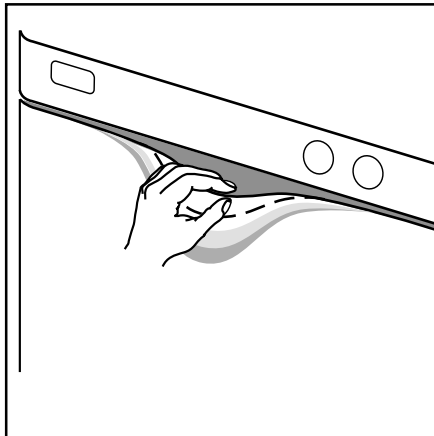

Fig. 6

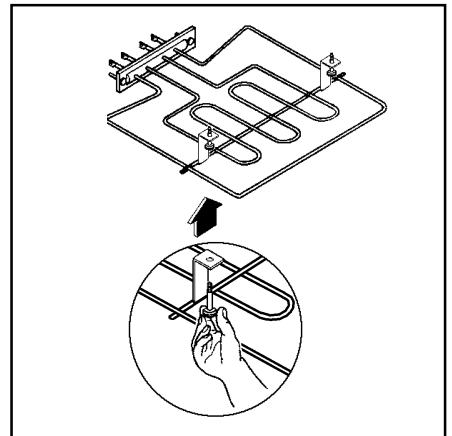

Fig. 10

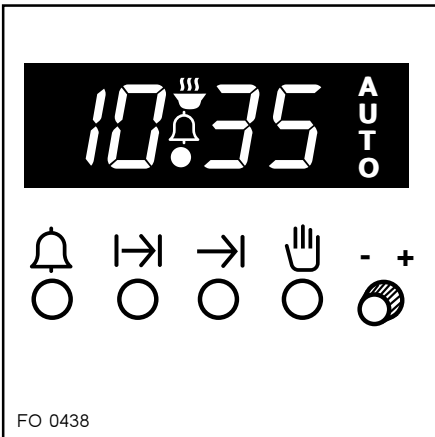

Fig. 3

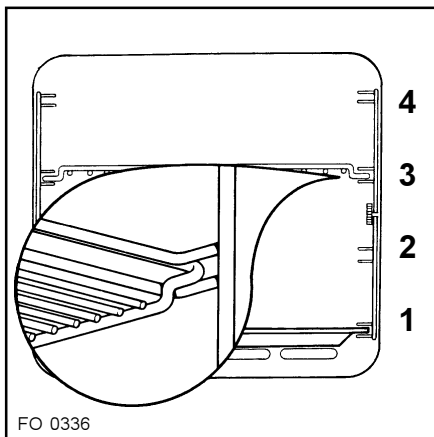

Fig. 7

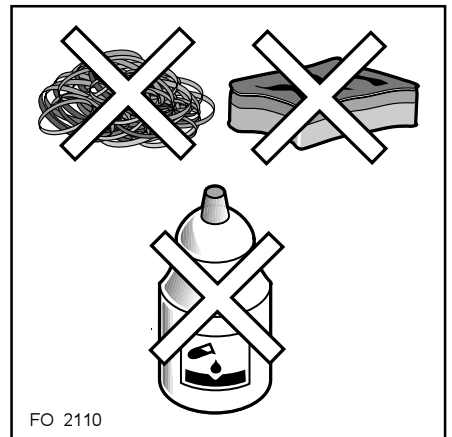

Fig. 11

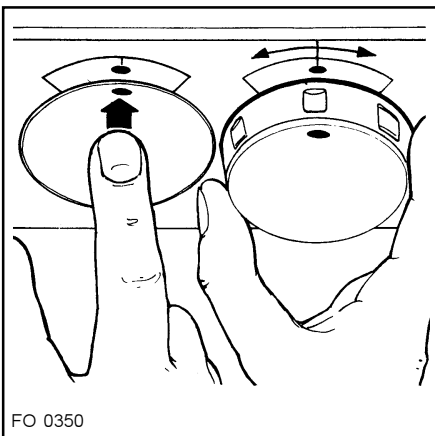

Fig. 4

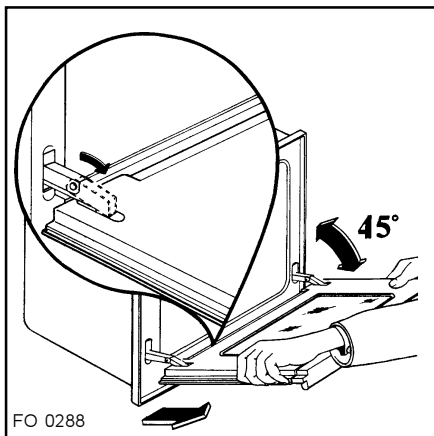

Fig. 8

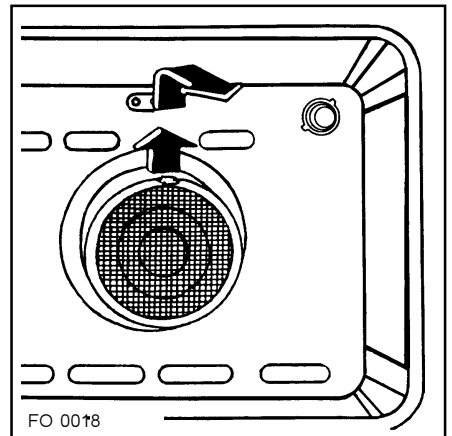

Fig. 12

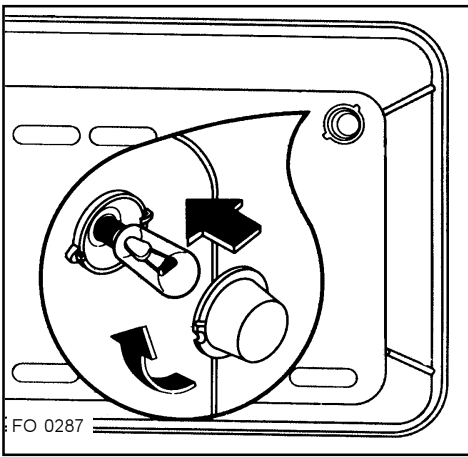

Fig. 13

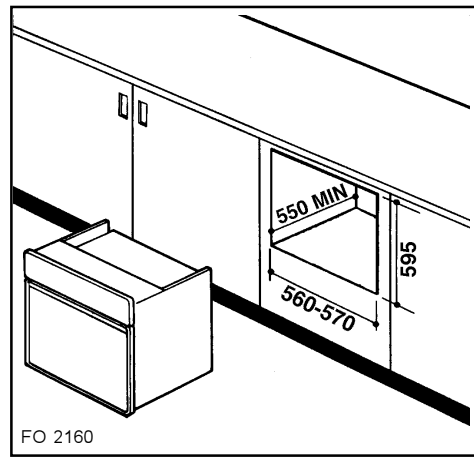

Fig. 17

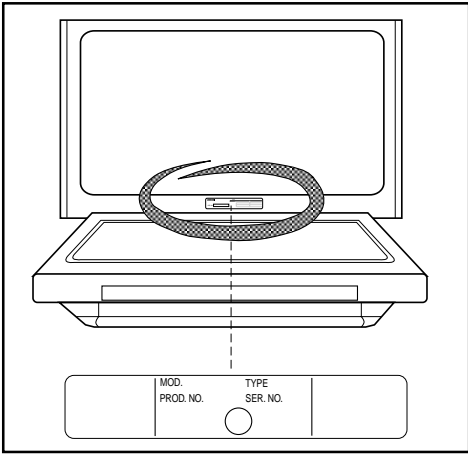

Fig. 14

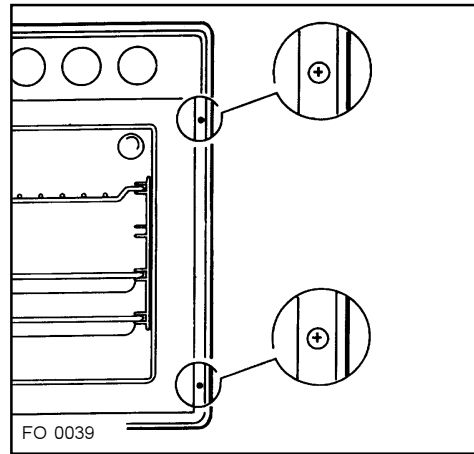

Fig. 18

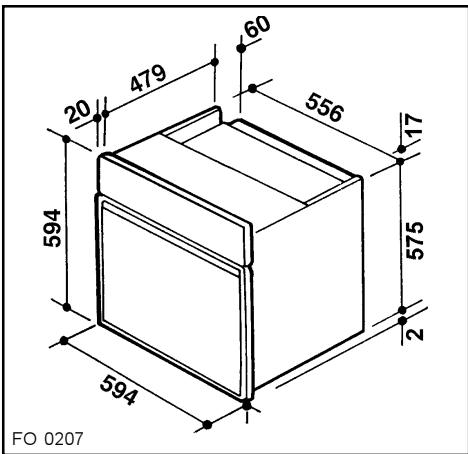

Fig. 15

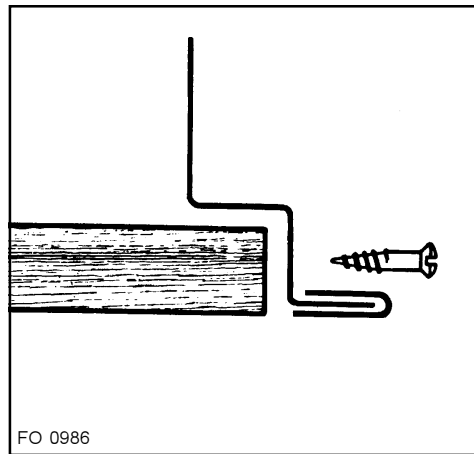

Fig. 19

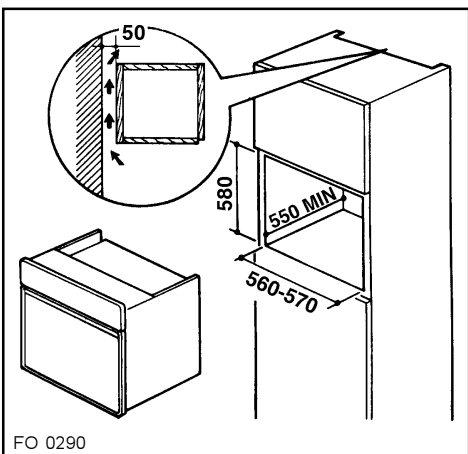

Fig. 16

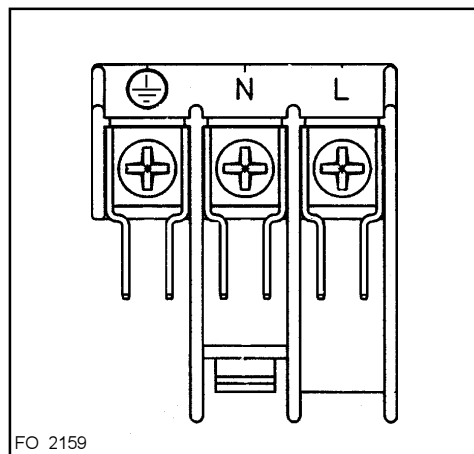

Fig. 20

ENGLISH

Important Safety Information



You **MUST** read these warnings carefully before installing or using the oven. If you need assistance, contact our Customer Care Department on 08705 727727

Installation

- This oven must be installed by **qualified personnel** to the relevant British Standards.
- This oven is heavy. Take care when moving it.
- Remove **all packaging**, both inside and outside the oven, before using the oven.
- Do not attempt to modify the oven in any way.

Child Safety

- This oven is designed to be operated by adults. Do not allow children to play near or with the oven.
- The oven gets hot when it is in use. Children should be **kept away** until it has cooled.

During Use

- This oven is intended for domestic cooking only. It is not designed for commercial or industrial purposes.
- Never line any part of the oven with **aluminium foil**.
- Do not allow heatproof cooking material, e.g. roasting bags, to come into contact with oven elements.
- **Never** place plastic or any other material which may melt in or on the oven.
- **Do not** place sealed cans or aerosols inside the oven. They may explode if they are heated.
- **Do not** hang towels, dishcloths or clothes from the oven or its handle.
- **Do not** use this oven if it is in contact with water and never operate it with wet hands.
- Take **great care** when heating fats and oils as they will ignite if they become too hot.
- **Always** use oven gloves to remove and replace food in the oven.
- Ensure that all control knobs are in the **OFF** position when not in use.
- **Do not** leave cookware containing foodstuffs, e.g. fat or oil in or on the oven in case it is inadvertently switched **ON**.
- When using other electrical appliances, ensure the cable does not come into contact with the hot surfaces of the cooking appliance.

Maintenance and Cleaning

- **Only** clean this oven in accordance with the instructions.
- The oven should be kept clean at all times. A build-up of fats or other foodstuffs could result in a fire, especially in the grill pan.
- Always allow the oven to cool down and switch off the electrical supply before carrying out any cleaning or maintenance work.

Service

- This oven should only be repaired or serviced by an authorised Service Engineer and only genuine approved spare parts should be used.

Environmental Information

- After installation, please dispose of the packaging with due regard to safety and the environment.
- When disposing of an old oven, make it unusable, by cutting off the cable. Remove any door catches, to prevent small children being trapped inside.

Keep this instruction book for future reference and ensure it is passed on to any new owner.

Oven Door Protection Device

(Stainless steel models)

All our appliances comply with the European safety standards. Nevertheless, in order to ensure the highest safety level, and avoid little children to be exposed to the heat when the oven is operated, it is possible to fit a special protection device to the oven door. This device can be purchased in our Service Force Centres, specifying the relevant code (35791) and the Product No. shown on the rating plate.

Contents

For the User









Important safety Information	Page	5
Controls	Page	6
24 hour Clock and Timer	Page	7
Before the First Use	Page	8
Using the Oven	Page	8
Using the Conventional Oven	Page	9
Using the fan Oven	Page	11
Defrosting	Page	12
Grilling	Page	13
Cleaning the oven	Page	14
Something not working	Page	16
Service And Spare Parts	Page	16
Customer Care	Page	17
Guarantee Conditions	Page	17

For the Installer

Installation	Page	20
Electrical Connection	Page	20
Building In	Page	21

Controls







Oven Function Control Knob (Fig. 1 - Page 3)

-  Oven Light - The oven light will be on without any cooking function
-  Defrost Setting - This setting is intended to assist in thawing of frozen food
-  Conventional cooking - The heat comes from both the top and bottom element, ensuring even heating inside the oven.
-  Top heating element - The heat comes from the top of the oven only.
-  Bottom heating element - The heat comes from the bottom of the oven only.
-  Fan cooking - This allows you to roast or roast and bake simultaneously using any shelf, without flavour transference.
-  Inner grill element only - can be used for grilling small quantities.
-  Double Grill - The full grill element will be on.
-  Thermal Grilling - This function offers an alternative method of cooking food items, normally associated with conventional grilling. The grill element and the oven fan operate together, circulating hot air around the food.

Thermostat Control Knob (Fig. 2 - Page 3)

Turn the thermostat control knob clockwise to select temperatures between 50°C and 250°C (MAX).

24 hour Clock and Timer (Fig. 3 - Page 3)

-  Minute minder
-  Cooking duration
-  End of cooking time
-  Manual function
-  Cookpot symbol - This will be displayed when a program is in operation.
-  Auto symbol - This will be displayed when the oven has been programmed for automatic operation.

- + Time setting knob



24 hour Clock and Timer

The electronic timer can indicate the time of day, operate as a minute minder and automatically operate the oven. Before the oven can be operated, the time of day must be set on the electronic timer.

Please note that this is a 24 hour clock. For example, 2pm is shown as 14:00.

In case of loss of power, all the settings (time of day, set program or program in operation), will be cancelled. When the power is restored, the numbers on the display will flash, and the timer has to be reset.

TO SET THE TIME OF DAY

Press buttons  and , and at the same time turn the time setting knob until the correct time of day is displayed.

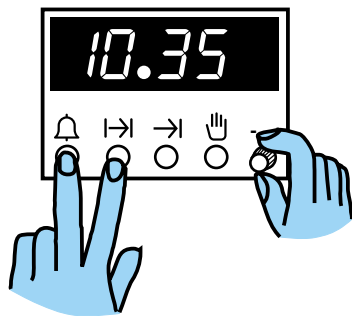

TO SET THE MINUTE MINDER

Press button  and at the same time turn the setting time knob until the duration time is displayed (max. 23 hours, 59 minutes).

Our diagram shows the timer set for 35 minutes. After a few seconds the time of day will show in the display.

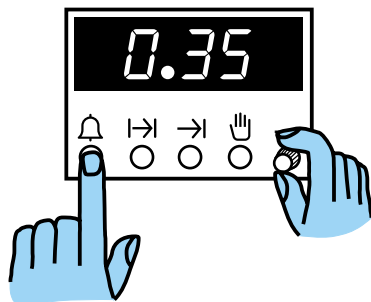

To check the number of minutes remaining, press the  button. At the end of the timed period an alarm will sound.

To switch off the alarm press button .

MANUAL FUNCTION

Press button  to set the oven for manual function.

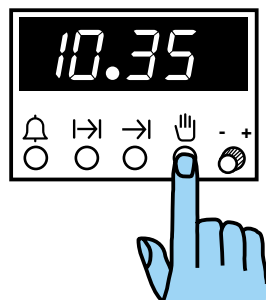

TO SET THE TIMER TO SWITCH OFF ONLY

This is useful if you want to begin cooking immediately but have the oven switch off automatically.

1. Set the oven function control knob and the thermostat control knob on the required settings.
2. Place food in the oven.
3. Press button  and, at the same time, turn the time setting knob until the required cooking duration is displayed.

Our diagram shows the timer set for 1 hour 10 minutes. At the end of the cooking time the oven will switch off, an alarm will sound.

To switch off the alarm press button .

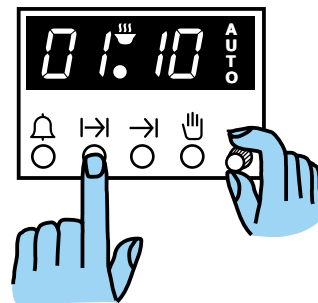



TO SET THE TIMER TO SWITCH THE OVEN ON AND OFF

1. Ensure the clock is showing the right time of day.
2. Carry out steps 1, 2 and 3 as explained in "To set the timer to switch off only".
3. Press button  and at the same time turn the time setting knob until the end cooking time is displayed.

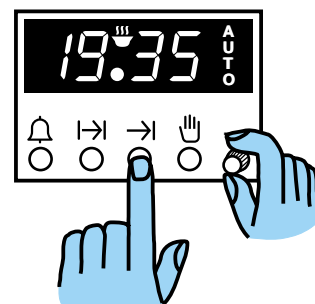
Our diagram shows the end cooking time set for 7:35 pm.



TO CANCEL A PROGRAMME

1. Press button  and, at the same time, turn the time setting knob until the cooking duration is set on "zero".
3. If the end cooking time has been set too, press button  and at the same time turn the time setting knob until the end cooking time is set on "zero".

Before the First Use



Remove all packaging, both inside and outside the oven, before using the oven.

Before first use, the oven should be heated without food. During this time, an unpleasant odour may be emitted. This is quite normal.

1. Switch the oven function control knob to conventional cooking
2. Set the thermostat control knob to MAX.
3. Open a window for ventilation.
4. Allow the oven to run empty for approximately 45 minutes.
5. Half way through, reset the oven function control to fan cooking

This procedure should be repeated with the grill

Using the Oven



• Always cook with the oven door closed.

- Stand clear when opening the drop down oven door. **Do not** allow it to fall open - support the door using the door handle, until it is fully open.
- The oven has four shelf levels (Fig. 7 Page 3), and is supplied with two shelves. The shelf positions are casted from the bottom of the oven as shown in the diagram.

It is important that these shelves are correctly positioned as shown in the diagram.

- Do not place cookware directly on the oven base.

Condensation and steam

When food is heated it produces steam in the same way as a boiling kettle. The oven vents allow some of this steam to escape. However, **always stand back from the oven when opening the oven door** to allow any build up of steam or heat to release.

If the steam comes into contact with a cool surface on the outside of the oven, e.g. a trim, it will condense and produce water droplets. This is quite normal and is not a fault with the oven.

To prevent discolouration, regularly wipe away condensation and also soilage from surfaces.

Push-Pull Control Knobs (Fig. 4 - Page 3)

All the models, **except model BMS 641 X**, are provided with push-pull control knobs.

These knobs can be completely sunken inside the control panel when the oven is not working.

Cookware

- Use any oven proof cookware which will withstand temperatures of 250°C.
- Baking trays, oven dishes, etc. should not be placed directly against the grid covering the fan at the back of the oven, or placed on the oven base.
- Do not use baking trays larger than 30 cm x 35 cm (12 in x 14 in) as they will restrict the circulation of heat and may affect performance.

The effects of dishes on cooking results

Dishes and tins vary in their thickness, conductivity, colour, etc. which affects the way they transmit heat to the food inside them.



- A** Aluminium, earthenware, oven glassware and bright shiny utensils reduce cooking and base browning.
- B** Enamelled cast iron, anodized aluminium, aluminium with non-stick interior and coloured exterior and dark, heavy utensils increase cooking and base browning.

Using the Conventional Oven

When using this setting, heat comes from both the top and bottom elements. This allows you to cook in a single level and is particularly suitable for dishes which require extra base browning such as pizzas, quiches and flans.

Gratins, lasagnes and hotpots which require extra top browning also cook well in the conventional oven. This form of cooking gives you the opportunity to cook without the fan in operation.

How to Use the Conventional Oven

1. Turn the oven function control knob to the required cooking function  -  - .
2. Turn the thermostat control to the required temperature.

Top oven element only

This function is suitable for finishing cooked dishes, eg; lasagne, shepherds pie, cauliflower cheese etc.

Bottom oven element only

This function is particularly useful when blind-baking pastry or cooking pizza. It may also be used to finish off quiches or flans to ensure the base pastry is cooked through.

THINGS TO NOTE

- The oven light will come on when the oven function control knob is set.
- The cooling fan will operate continually during cooking. It may run on after the oven is switched off to keep the controls cool. This is quite normal.
- The thermostat control light will remain on until the correct temperature is reached. It will then cycle on and off to show that temperature is being maintained.

NOTE

The action of the cooling fan will depend on how long the oven has been used and at what temperature. It may not switch in at all at lower temperature settings nor run on where the oven has only been used for a short time.

Hints and Tips

The middle shelf position allows for the best heat distribution. To increase base browning simply lower the shelf position. To increase top browning, raise the shelf position.

The material and finish of the baking trays and dishes used will affect base browning. Enamelware, dark, heavy or non-stick utensils increase base browning, while oven glassware, shiny aluminium or polished steel trays reflect the heat away and give less base browning.

Always place dishes centrally on the shelf to ensure even browning.

Stand dishes on suitably sized baking trays to prevent spillage onto the base of the oven and make cleaning easier.

Do not place dishes, tins or baking trays directly on the oven base as it becomes very hot and damage will occur.

For faster preheating use the fan oven function to preheat the oven until the oven indicator neon goes out, then switch the selector to the conventional oven setting.

Single level cooking gives best results. If you require more than one level cooking use the fan oven function.

Cooking Chart - Conventional Oven

Food	Temperature (°C)	Runner Positions	Cooking Time (mins)
Biscuits	170-200	2 / 3	25-30
Bread, buns, yeast, doughs	200-230	2	35-45
Casseroles	140-170	2	90-180
Cakes - small, Queen Victoria sponge	170-190	2 / 3	18-25
Cakes - madeira, rich fruit	130-180	2	90-150
Choux pastry, eclairs	200-230	2	30-35
Fish	200-230	2 / 3	20-40
Fruit pies, plate tarts, crumbles	180-210	2	50-65
Meringues	90-100	2	90-150
Milk puddings	140-160	2	90-150
Pate, terrine (in baine-marie)	160-180	1	60-90
Pizzas	200-230	2	25-30
Puff pastry, sausage rolls, vol-au-vents	230-260	2	15-25
Quiches, flans	170-200	2	50-60
Scones	230-250	2 / 3	8-12
Souffle	200-230	2	35-45
Stuffed vegetables	230-250	2	35-45
Roast meat & poultry	160-180	2	see meat + poultry roasting chart
Yorkshire pudding	200-230	2	40-50
Keep food warm, heat dishes	90-100	2	

Meat and Poultry Roasting Chart (Conventional Oven + Fan Oven)

Meat	Cooking Time
Beef	20-35 mins per 1/2kg (lb) + 20-35 mins
Beef, boned	25-35 mins per 1/2kg (lb) + 25-35 mins
Mutton and Lamb	25-35 mins per 1/2kg (lb) + 25-35 mins
Pork and Veal	30-40 mins per 1/2kg (lb) + 30-40 mins
Ham	30-40 mins per 1/2kg (lb) + 30-40 mins
Chicken	15-20 mins per 1/2kg (lb) + 20 mins
Turkey and Goose	15-20 mins per 1/2kg (lb) up to 3.5kg (7lb) + 15 mins per 1/2kg
Duck	25-35 mins per 1/2kg (lb) + 20 mins

When roasting, ensure the meat is cooked thoroughly, use a meat thermometer if preferred to check the centre temperature has reached the required temperature (see table below).

MEAT	TEMPERATURES
Beef	Rare - 60°C Medium - 70°C Well Done - 80°C
Pork	Well Done - 80°C
Lamb	Medium - 70°C Well Done - 80°C

Using the Fan Oven

The air inside the oven is heated by the element around the fan situated behind the back panel. The fan circulates hot air to maintain an even temperature inside the oven.

The advantages of cooking with this function are:
Faster Preheating

As the fan oven quickly reaches temperature, it is not usually necessary to preheat the oven although you may find that you need to allow an extra 5-7 minutes on cooking times. For recipes which require higher temperatures, best results are achieved if the oven is preheated first, e.g. bread, pastries, scones, souffles, etc.

Lower Temperatures

Fan oven cooking generally requires lower temperatures than conventional cooking.

Follow the temperatures recommended in the cooking chart or remember to reduce temperatures by about 20-25°C for your own recipes which use conventional cooking.

Even Heating for Baking

The fan oven has uniform heating on all runner positions. This means that batches of the same food can be cooked in the oven at the same time. However, the top shelf may brown slightly quicker than the lower one. This is quite usual. There is no mixing of flavours between dishes.

How to use the Fan Oven

1. Turn the oven function control knob to .
2. Turn the thermostat control to the required.

THINGS TO NOTE: During cooking, the cooling fan and the thermostat control light will operate in the same way as described for the conventional oven function.

Hints and Tips

- Runner positions are not critical, but make sure the shelves are evenly spread.
- When cooking more than one dish in the fan oven, place dishes centrally on the shelves rather than several dishes on one shelf.
- When the oven is full, you may need to allow slightly longer cooking time.
- A shelf may be placed on the floor of the oven. Place dishes on a shelf in this position rather than on the oven base, to allow air circulation around the food.
- When the oven is full of the same food, e.g. equal trays of small cakes or equal size victoria sandwich cakes, then they will be cooked in the same time and removed from the oven together. When different sizes of trays or types of food, e.g. biscuits and cakes are cooked, they will not necessarily be ready together.
- The fan oven can be used to heat foods through without thawing first, e.g. fruit tarts, mince pies, sausage rolls, and other small pastry items. Use a temperature of 190-200°C and allow 20-40 minutes (depending on the quantity of food in the oven).
- The use of too high temperatures can cause uneven browning. Check with the recommendations for oven temperatures given in the cooking charts, but be prepared to adjust the temperature by 10°C if necessary. Remember to reduce temperatures by about 20-25°C for your own conventional recipes.
- The meat tin **should not** be placed on a heated hotplate or burner as this may cause the enamel to crack.

Cooking Chart

This chart is intended as a guide only. It may be necessary to increase or decrease the temperature to suit your individual requirements. Only experience will enable you to determine the correct setting for your personal requirements.

When roasting, ensure the meat is cooked thoroughly, use a meat thermometer if preferred to check the centre temperature has reached the required temperature (see table below).

MEAT	TEMPERATURES
Beef	Rare - 60°C Medium - 70°C Well Done - 80°C
Pork	Well Done - 80°C
Lamb	Medium - 70°C Well Done - 80°C

Food	Shelf Position	Cooking Temp (°C)	
Biscuits	Shelf positions are not critical but ensure that oven shelves are evenly spaced when more than one is used.	180-190	
Bread		210-220	
Casseroles		130-140	
Cakes: Small and queen		160-170	
Sponges		160-170	
Madeira		140-150	
Rich Fruit		130-140	
Christmas		130-140	
Meringues		90-100	
Fish		170-190	
Fruit Pies and Crumbles		190-200	
Milk Puddings		130-140	
Pastry: Choux		}	180
Shortcrust			
Flaky			
Puff			
Plate Tarts		170-180	
Quiches/Flans		210-220	
Scones		160-180	
Roasting: Meat & Poultry			

Defrosting

The oven fan operates without heat and circulates the air, at room temperature, inside the oven. This increases the speed of defrosting. However, please note that the temperature of the kitchen will influence the speed of defrosting.

This function is particularly suitable for delicate food which could be damaged by heat, e.g. cream filled gateaux, iced cakes, pastries, bread and other yeast products.

How to Use Defrosting

1. Turn the oven function control knob to .
2. Ensure the thermostat control knob is in the OFF position.

Hints and Tips

- Cover food with a lid, aluminium foil or plastic film to prevent drying out during defrosting.
- ALWAYS COOK THOROUGHLY IMMEDIATELY AFTER THAWING.
- Frozen food should be placed in a single layer when ever possible and turned over half way through the defrosting process.
- Only joints of meat and poultry up to 2 kg. (4 lb.) are suitable for defrosting in this way.

Refer to the following table for approximate defrosting times.

Food	Defrosting time (Mins)	Standing time (Mins)	Notes
Chicken 1000 g.	100-140	20-30	Place the chicken on an inverted saucer on a large plate. Defrost open and turn at half time or defrost covered with foil. Remove giblets as soon as possible.
Meat 1000 g.	100-140	20-30	Defrost open and turn at half time or cover with foil
Meat 500 g.	90-120	20-30	As above
Trout 150 g.	23-35	10-15	Defrost open
Strawberries 300 g.	30-40	10-20	Defrost open
Butter 250 g.	30-40	10-15	Defrost open
Cream 2 x 200 g.	80-100	10-15	Defrost open (cream is easy to whip even if parts of it are still slightly frozen)
Cake 1400 g.	60	60	Defrost open

The times quoted in the chart should be used as a guide only, as the speed of defrosting will depend on the kitchen temperature. For example, the colder the ambient temperature, the longer the defrosting time.



Grilling must be carried out with the oven door closed. The grill pan handles must be removed from the pan.

How to Use the Grill

1. Turn the oven control function knob on .
2. Turn the thermostat control knob on the required temperature.
3. Adjust the grid and grill pan runner position to allow for different thicknesses of food. Position the food close to the element for faster cooking and further away for more gentle cooking.

Preheat the grill on a full setting for a few minutes before sealing steaks or toasting. Adjust the heat setting and the shelf as necessary, during cooking

During cooking, the cooling fan and the thermostat control light will operate in the same way as described for the fan oven function.

Hints and Tips

- Most foods should be placed on the grid in the grill pan to allow maximum circulation of air to lift the food out of the fats and juices. Food such as fish, liver and kidneys may be placed directly on the grill pan, if preferred
- Food should be thoroughly dried before grilling to minimise splashing. Brush lean meats and fish lightly with a little oil or melted butter to keep them moist during cooking
- Accompaniments such as tomatoes and mushrooms may be placed underneath the grid when grilling meats
- When toasting bread, we suggest that the top runner position is used.
- The food should be turned over during cooking, as required.

The grill element is controlled by the thermostat. During cooking, the grill cycles on and off to prevent overheating.

How to Use the Inner Grill Element

The inner grill provides quick direct heat to the central area of the grill pan. By using the inner grill element for cooking small quantities, it can help to save energy.

1. Turn the oven control function knob on .
2. Turn the thermostat control knob on the required temperature.
3. Adjust the grid and grill pan runner position to allow for different thicknesses of food and follow the instructions for grilling.

How to Use the Thermal Grill

Thermal grill offers an alternative method of cooking food items normally associated with conventional grilling. The grill element and the oven fan operate alternately, circulating hot air around the food. The need to check and turn the food is reduced. Thermal grilling helps to minimize cooking smells in the kitchen.

With the exception of toast and rare steaks, you can thermally grill all the foods you would normally cook under a conventional grill. Cooking is more gentle, therefore food generally takes a little longer to cook with thermal grilling compared with conventional grilling. One of the advantages is that larger loads can be cooked at the same time.

1. Turn the oven control function knob on .
2. Turn the thermostat control knob on the required temperature. **Select a maximum temperature of 200°C.**
3. Adjust the grid and grill pan runner position to allow for different thicknesses of food and follow the instructions for grilling.

Hints and Tips

Prepare foods in the same way as for conventional grilling. Brush lean meats and fish lightly with little oil or butter to keep them moist during cooking.

A general guide to cooking times is given below but these times may vary slightly depending on the thickness and quantity of food being cooked.

Cooking Chart - Grilling

FOOD	Grill and Inner Grill Element		Thermal Grill	
	Temp (°C)	Time (Mins per side)	Temp (°C)	Time (Mins)
Bacon Rashers	210	2-3	200	8-12
Beefburgers	200	6-10	190	10-15
Chicken Joints	170	10-15	160	35-45
Chops - Lamb	180	7-10	170	20-25
- Pork	180	10-15	170	25-35
Fish - Whole Trout/Herring	170	8-12	170	10-20
- Fillets Plaice/Cod	170	4-6	170	10-20
Kebabs	180	10-15	170	20-30
Kidneys - Lamb/Pig	170	4-6	180	10-15
Liver - Lamb/Pig	170	5-10	180	20-30
Sausages	180	10-15	190	10-15
Toast	250	1-2	--	
Heating through and Browning, e.g. au-gratin, lasagne, shepherd's pie.	-	-	170 depending on size	20-30 depending on size
Browning dishes only	230	3-5	--	

Cleaning the Oven



Before cleaning always allow the cooling fan to cool the oven down before switching off at the electricity supply.

The oven should be kept clean at all times. A build-up of fats or other foodstuffs could result in a fire, especially in the grill pan.

Cleaning materials

Before using any cleaning materials on your oven, check that they are suitable and that their use is recommended by the manufacturer.

Cleaners that contain bleach should NOT be used as they may dull the surface finishes. Harsh abrasives should also be avoided.

External cleaning

Regularly wipe over the control panel, oven door and door seal using a soft cloth well wrung out in warm water to which a little liquid detergent has been added.



To prevent damaging or weakening the door glass panels avoid the use of the following:

- Household detergent and bleaches
- Impregnated pads unsuitable for non-stick saucepans
- Brillo/Ajax pads or steel wool pads
- Chemical oven pads or aerosols
- Rust removers
- Bath/Sink stain removers

Clean the outer and inner door glass using warm soapy water. Should the inner door glass become heavily soiled it is recommended that a cleaning product such as Hob Brite is used. Do not use paint scrapers to remove soilage.



DO NOT clean the oven door while the glass panels are warm. If this precaution is not observed the glass panel may shatter.

If the door glass panel becomes chipped or has deep scratches, the glass will be weakened and must be replaced to prevent the possibility of the panel shattering. Contact your local Service Centre who will be pleased to advise further.

Grease Filter (Fig. 12 - Page 3)

To prevent a build-up of fats on the fan impellor, the grease filter must be fitted by clipping it over the vents in the back panel.

To clean the grease filter

When the oven has cooled down, remove the filter by pushing the protruding tongue on the filter upward, and wash carefully.

The grease filter should be cleaned after every use. The filter may be washed in a dishwasher on a 65°C wash. If the filter is heavily soiled, place the filter in a saucepan of water with approximately 1 teaspoon of automatic washing powder or dishwasher powder. Bring to the boil and leave to soak for approximately 30 minutes or longer depending on the degree of soiling. Ensure the solution does not boil over as it could mark your hob.

Rinse filter in clear water and dry.

Remember to refit the filter before using the oven again.

Replacing the Oven Light (Fig.13 - Page 4)

If the oven bulb needs replacing, it must comply with the following specifications:

- Electric power: 25W,
- Electric rate: 230-240 V (50 Hz),
- Resistant to temperatures of 300°C,
- Connection type: E14.

These bulbs are available from your local Zanussi Force Service Centre.

To replace the faulty bulb:

1. Ensure the oven is isolated from the electrical supply.
2. Turn the glass cover anticlockwise.
3. Remove the faulty bulb and replace with the new one.
4. Refit the glass cover.
5. Restore the electrical supply.

Cleaning the hinged grill (Fig.10 - Page 3)

This model has been fitted with a hinged grill element to enable you to clean the roof of the oven easily.

 **Before proceeding ensure the oven is cool and is isolated from the electricity supply.**

- 1) Undo the screws which holds the grill in place (Fig.10 - Page 3). When doing this operation for the first time, we recommend using a screwdriver.
- 2) Then gently pull the grill downward to allow access to the oven roof.
- 3) Clean the oven roof with a suitable cleaner and wipe dry before replacing the hinged grill element.
- 4) Gently push up the grill element into place and firmly screw into place the holding nuts.

 **Ensure the grill holding nuts are firmly in place to avoid the grill falling down when in use.**

Oven Shelves

To clean the oven shelves, soak in warm soapy water and remove stubborn marks with a well wetted soap impregnated pad. Rinse well and dry with a soft cloth. The shelf supports can be removed for easy cleaning (see diagram). Please, ensure the retaining nuts are secure when refitting the shelf support.

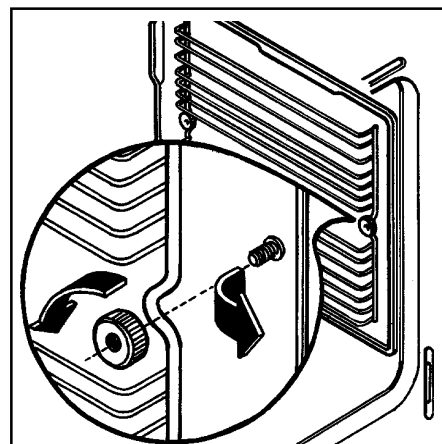

Oven Cavity

The enamelled oven cavity is best cleaned whilst the oven is still warm.

Wipe the oven over with a soft cloth soaked in warm soapy water after each use. From time to time it will be necessary to do a more thorough cleaning, using a proprietary oven cleaner.

If the soilage has become set, after the oven has cooled down, the following process will help to soften the splatters to help make cleaning easier.

1. Place the grill/ meat pan on the oven shelf positioned in the lowest runner.
2. Add a few drops of washing-up liquid to the pan and fill to about 12 mm. with boiling water from the kettle.
3. Close the oven door, turn the oven function knob on fan oven  and set the thermostat knob on 50°C.
4. After 15 minutes, turn off the thermostat and allow the fan oven to continue without heat for a further 5 minutes, when the temperature of the water will have cooled down.
5. Carefully remove the pan of water from the oven and use normal oven cleaners to clean away soil residues.
6. Leave a little of the soapy water to soak into any burned on spillage on the floor of the oven for a longer time if necessary.

Something not working

If the oven is not working correctly, please carry out the following checks, before contacting your local Service Centre.

SYMPTOM	SOLUTION
<ul style="list-style-type: none"> ■ The oven does not come on 	<ul style="list-style-type: none"> ◆ Check the oven is in manual operation and that both a cooking function and temperature have been selected. ◆ Check the oven is wired in properly, and the socket switch or the switch from the mains supply to the oven are ON.
<ul style="list-style-type: none"> ■ The oven temperature light does not come on 	<ul style="list-style-type: none"> ◆ Select a temperature with the thermostat control knob ◆ Select a function with the oven function control knob.
<ul style="list-style-type: none"> ■ The oven light does not come on 	<ul style="list-style-type: none"> ◆ Select a function with the oven function control knob ◆ Check the light bulb, and replace it if necessary (see "Cleaning the Oven")
<ul style="list-style-type: none"> ■ It takes too long to finish the dishes, or they are cooked too fast. 	<ul style="list-style-type: none"> ◆ The temperature may need adjusting ◆ Refer to the contents of this booklet, especially to the chapter "Using the Oven".
<ul style="list-style-type: none"> ■ Steam and condensation settle on the food and the oven cavity. 	<ul style="list-style-type: none"> ◆ Leave dishes inside the oven no longer than 15-20 minutes after the cooking is completed.
<ul style="list-style-type: none"> ■ The timer does not work 	<ul style="list-style-type: none"> ◆ Check the instructions for the timer.
<ul style="list-style-type: none"> ■ The oven fan is noisy 	<ul style="list-style-type: none"> ◆ Check the grease filter is correctly fitted. ◆ Check that shelves and bakeware are not vibrating in contact with the oven back panel.

Service and Spare Parts

SERVICE FORCE

In the event of your appliance requiring service, or if you wish to purchase spare parts, please contact your local Zanussi Service Force Centre by telephoning:

0870 5 929929

Your telephone call will be automatically routed to the Service Force Centre covering your post code area. The addresses are listed on the following pages.

Before calling out an engineer, please ensure you have read the details under the heading "Something Not Working."

When you contact the Service Force Centre you will need to give the following details:

1. Your name, address and post code
2. Your telephone number
3. Clear and concise details of the fault
4. The model and serial number of the appliance (found on the rating plate)
5. The purchase date

In-guarantee customers should ensure that the above checks have been made as the engineer will make a charge if the fault is not a mechanical or electrical breakdown.

Customer Care

For general enquiries concerning your Zanussi appliance or for further information on Zanussi products, please contact our Customer Care Department by letter or telephone at the address below or visit our website at www.zanussi.co.uk

Customer Care Department

Zanussi
55-77 High Street
Slough
Berkshire
SL1 1DZ
08705 727727 (*)

* calls to this number may be recorded for training purposes.

Guarantee Conditions

ZANUSSI GUARANTEE CONDITIONS

We, Zanussi, undertake that if, within 24 months of the date of the purchase, this Zanussi appliance or any part thereof is proved to be defective by any reason only of faulty workmanship or materials, we will, at our option, repair or replace the same FREE OF ANY CHARGE for labour, materials or carriage on condition that:

- * The appliance has been correctly installed and used only on the gas and electricity supply stated on the rating plate.
- * The appliance has been used for normal domestic purpose only, and in accordance with the manufacturer's instructions.
- * The appliance has not been serviced, maintained, repaired, taken apart or tampered with by any person not authorised by us.
- * All service work under this guarantee must be undertaken by a Zanussi Service Centre.
- * Any appliance or defective part replaced shall become the Company's property.
- * This guarantee is in addition to your statutory and other legal rights.

Home visits are made between **8.30am and 5.30pm** Monday to Friday. Visits may be available outside these hours, in which case a **premium** will be charged.

Exclusions

This guarantee does not cover:

- * Damage or calls resulting from transportation, improper use or neglect, the replacement of any light bulbs or removable parts of glass or plastic.
- * Costs incurred for calls to put right an appliance which is improperly installed or calls to appliance outside the United Kingdom.

- * Appliances found to be in use within a commercial or similar environment, plus those which are the subject to rental agreements.
- * Products of Zanussi manufacture which are not marketed by Zanussi.

European Guarantee

If you should move to another country within Europe then your guarantee moves with you to your new home subject to the following qualifications:

- * The guarantee starts from the date you first purchased your product.
- * The guarantee is for the same period and to the same extent for labour and parts as exist in the new country of use for this brand or range of products.
- * This guarantee relates to you and cannot be transferred to another user.
- * Your new home is within the European Community (EC) or European Free Trade Area.
- * The product is installed and used in accordance with our instructions and is only used domestically, i.e. a normal household
- * The product is installed taking into account regulations in your new country.

Before you move, please contact your nearest Customer Care centre, listed below, to give them details of your new home. They will then ensure that the local Service Organisation is aware of your move and able to look after you and your appliances.

France	Senlis	+33 (0)3 44 62 29 99
Germany	Nürnberg	+49 (0)911 323 2600
Italy	Pordenone	+39 (0)1678 47053
Sweden	Stockholm	+46 (0)8 738 79 50
UK	Slough	+44 (0)1753 219897

To contact your local Service Force Centre telephone **08705 929 929**

CHANNEL ISLANDS		ISLE OF LEWIS	NORTHEAST	
GUERNSEY	Guernsey Electricity PO Box 4 Vale, Guernsey Channel Islands GY1 3AD	ND Macleod 16 James Street Stornoway Isle of Lewis PA87 2QW	GATESHEAD Unit 356a Dukesway Court Dukesway Gateshead NE11 0BH	
JERSEY	Jersey Electricity Company Haut De L'orme Rue De Haut De L'orme Trinity Jersey Channel Islands JE3 5FG	KELSO 2, 6 & 8 Woodmarket Kelso Borders TD57AX	GRIMSBY 15 Hainton Avenue Grimsby N. E. Lincs DN32 9AS	
SCOTLAND		ORKNEY 7 King Street Kirkwall Orkney KW15 1JF	HULL Unit 1 Boulevard Industrial Estate Hull HU34AY	
ABERDEEN	54 Claremont Street Aberdeen AB10 6RA	PERTH Scottish Hydro Electric Central Warehouse Inveralmond Perth PH1 3AF	LEEDS 64-66 Cross Gates Road Cross Gates Leeds LS15 7YS	
AUCHTERMUCHTY	33a Burnside Auchtermuchty Fife KY14 7AJ	(OWN SALES)	NEWTON AYCLIFFE Unit 23 Northfield Way Aycliffe Industrial Park Newton Aycliffe DL5 6EJ	
BLANTYRE	Unit 5 Block 2 Auchenraith Ind. Estate Rosendale Way Blantyre G72 0NJ	SHEETLAND 3-4 Carlton Place Lerwick Shetland ZE1 0PW	SHEFFIELD Pennine House Roman Ridge Road Sheffield S9 1GB	
DUMFRIES	93 Irish Street Dumfries DG1 2 PQ	SHEETLAND Bolts Shetland 26 North Road Lerwick Shetland ZE1 0PE	NORTHWEST	
DUNOON	7 Hill Street Dunoon Argyll PA23 7AL	WHALSAY Leask Electrical Harisdale Symbister, Whalsay Shetland ZE2 9AA	BIRKENHEAD 1 Kelvin Park Dock Road Birkenhead CH41 1LT	CARLISLE Unit 7 James Street Workshops James Street Carlisle Cumbria CA2 5AH
EDINBURGH	Unit 12 Dumbyden Ind. Estate 2 Dumbyden Road Edinburgh EH14 2AB	NORTHERNIRELAND		
GLASGOW Unit 4	Wellington Road Bishopriggs Glasgow G64 2SA	BELFAST Owenmore House Kilwee Business Park Dunmurry Belfast BT17 0HD	ISLE OF MAN South Quay Ind. Estate Douglas Isle of Man IM1 5AT	
INVERNESS	Unit 3BI Smithton Ind. Estate Smithton Inverness IV2 7WL	WALES		
ISLE OF ARRAN	R Haggerty Bruach Blackwaterfoot Isle of Arran	CARDIFF Unit 4 Guardian Industrial Estate Clydesmuir Road Cardiff CF2 2QS	BOLTON Unit B Central Industrial Estate St Marks Street Bolton BL3 6NR	
ISLE OF BARRA	J Zerfah 244 Bruernish Isle of Barra Western Islands HS9 5QY	CLYWD Unit 6-7 Coed Parc Abergele Road Rhuddlan Clwyd LL18 5UG	PRESTON Unit 250 Dawson Place Bamber Bridge Preston Lancashire PR5 8AL	
ISLES OF BUTE	Walker Engineering Glenmhor Upper Serpentine Road Rothesay Isle of Bute PA20 9EH	DYFED Unit 9 St. Clears Business Park Tenby Road St. Clears Carmarthen SA33 4JW	STOCKPORT Unit 20 Haigh Park Haigh Avenue Stockport SK4 1QR	
		OSWESTRY Plas Ffynnon Warehouse Middleton Road Oswestry SY11 2PP		

To contact your local Service Force Centre telephone **08705 929 929**

MIDLANDS		LONDON & EAST ANGLIA		SOUTHEAST	
BIRMINGHAM	66 Birch Road East Wyrley Trading Estate Witton Birmingham B6 7DB	BECKENHAM	11a Gardner Ind. Estate Kent House Lane Beckenham Kent BR3 1QZ	ASHFORD	Unit 2 Bridge Road Business Centre Bridge Road Ashford Kent TN23 1BB
BOURNE	Pinfold Road Bourne PE10 9HT	CHELMSFORD	Hanbury Road Widford Ind. Estate Chelmsford Essex CM12 3AE	FLEET	Unit 1 Redfields Ind. Estate Church Crookham Fleet Hampshire GU13 0RD
BRIDGNORTH	68 St. Mary's Street Bridgnorth Shropshire WV16 4DR	COLINDALE	Unit 14 Capitol Park Capitol Way Colindale London NW9 0EQ	HAYWARDS HEATH	21-25 Bridge Road Haywards Heath Sussex RH16 1UA
GLOUCESTER	101 Rycroft Street Gloucester GL1 4NB	ELTHAM	194 Court Road Mottingham Eltham London SE9 4EW	TONBRIDGE	Unit 30 Deacon Trading Estate Morley Road Tonbridge TN9 1RA
HEREFORD	Units 3 & 4 Bank Buildings Cattle market Hereford HE4 9HX	ENFIELD	284 Alma Road Enfield London EN3 7BB	SOUTHWEST	
HIGHAM FERRERS	30 High Street Higham Ferrers Northants NN10 8PL	GRAVESEND	Unit B4 Imperial Business Estate West Mill Gravesend Kent DA11 0DL	BARNSTAPLE	Main Road Fremington Barnstaple North Devon EX31 2NT
ILKESTON	Unit 2 Furnace Road Ilkeston DE7 5EP	IPSWICH	Unit 6C Elton Park Business Centre Hadleigh Road Ipswich IP2 0DD	BOURNEMOUTH	63-65 Curzon Road Bournemouth Dorset BH1 4PW
LEICESTER	Unit 7 Oaks Industrial Estate Coventry Road Narborough Leicestershire LE9 5GF	LETCHEWORTH	16-17 Woodside Ind. Park Works Road Letchworth Herts SG6 1LA	BRIDGEWATER	6 Herswell Business Park Salmon Parade Bridgwater Somerset TA65PY
LINCOLN	Unit 8 Clifton Street Stone Field Park Lincoln LN5 8LQ	LONDON	2 - 4 Royal Lane Yiewsley West Drayton Middlesex UB7 8DL	BRISTOL	11 Eldon Way Eldonwall Trading Estate Bristol BS4 3QQ
NEWCASTLE UNDER LYME	18-21 Croft Road Brampton Ind. Estate Newcastle under Lyme Staffordshire ST50TW	MAIDENHEAD	Reform Road Maidenhead Berkshire SL6 8BY	EMSWORTH	266 Main Road Southbourne Emsworth PO10 8JL
REDDITCH	13 Thornhill Road North Moons Moat Redditch Worcestershire B98 9ND	MOLESEY	10 Island Farm Avenue West Molesey Surrey KT8 2UZ	ISLE OF WIGHT	Unit 8 Enterprise Court Ryde Business Park Ryde Isle of Wight PO33 1DB
TAMWORTH	Unit 3 Sterling Park Claymore Tamworth B77 5DQ	NEWBURY	9 Pipers Court Berkshire Drive Thatcham Berkshire RG19 4ER	NEWTON ABBOT	Unit 2 Zealley Ind. Estate Kingsteignton Newton Abbot TQ12 3TD
WORCESTER	Units 1 & 2 Northbrooks Close Gregorys Mill Ind. Estate Worcester WR3 8BP	NORWICH	2b Trafalgar Street Norwich NR1 3HN	REDRUTH	Unit 7D Pool Ind. Estate Druids Road Redruth Cornwall TR15 3RH
		SUNBURY	Unit 1a The Summit Hanworth Road Sunbury on Thames TW16 5DB		

Installation



The oven must be installed according to the instructions supplied.



This oven must be installed by **qualified personnel** to the relevant British Standards.

Technical Data

DIMENSIONS OF RECESS	Height	580 mm.
	Width	560-570 mm.
	Depth	550 mm.

DIMENSIONS OF THE OVEN CAVITY	Height	320 mm.
	Width	420 mm.
	Depth	390 mm.
	Oven capacity	53.2 litres

Heating elements rating (230 V)

Oven element	1.8 kW
Top element	0.8 kW
Bottom element	1.0 kW
Convection element	2.0 kW
Grill element	1.75 kW
Double Grill element	2.55 kW
Convection Fan	30 W
Oven Light	25 W
Cooling Fan	25 W
Total Rating (230-240 V)	2.6 kW

Electrical Connection

The oven is designed to be connected to 230-240V (50Hz) electricity supply.

The oven has an easily accessible terminal block which is marked as follows:

- Letter L - Live terminal
Letter N - Neutral terminal
 - Earth terminal

THIS OVEN MUST BE EARTHED

Model BMS 641 is provided with a type H05RR-F connection cable with section 3x1,5 mm².

Model BST 6 is supplied without connection cable. A suitable one must be fitted to the appliance, according to the following type list:

- H07 RN-F
- H05 RN-F
- H07 RR-F
- H05 VV-F

It is necessary that you install a double pole switch between the oven and the electricity supply (mains), with a minimum gap of 3mm between the switch contacts and of a type suitable for the required load in compliance with the current rules.

The switch must not break the yellow and green earth cable at any point.

Important

After installation and connecting, the cable must be placed so that it cannot at any point reach a temperature of more than 60°C above the ambient temperature.

Before the oven is connected, check that the main fuse and the domestic installation can support the load; and that the power supply is properly earthed.

The manufacturer disclaims any responsibility should these safety measures not be carried out.

Building In

Please ensure that when the oven is installed it is easily accessible for the engineer in the event of a breakdown.

The surround or cabinet into which the oven will be built must comply with these specifications:

- the dimensions must be as shown in the relevant diagrams;
- the materials must withstand a temperature increase of at least 60°C above ambient;
- proper arrangements must be made of a continuous supply of air to the oven to prevent the oven overheating.

Dimensions of the oven and recess required are given in the relevant diagrams.

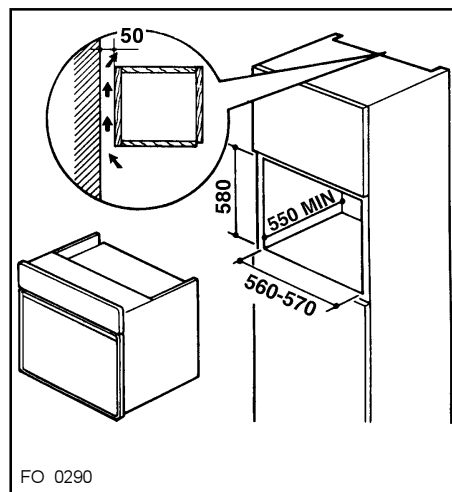
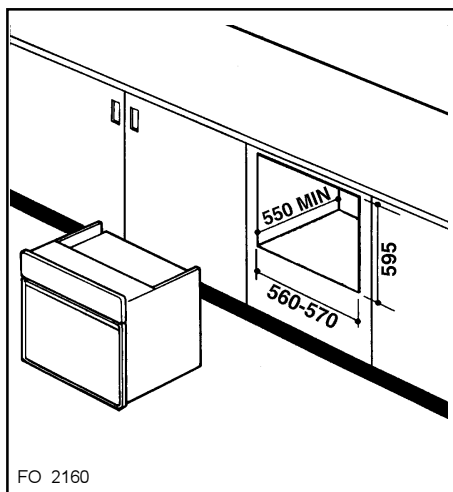
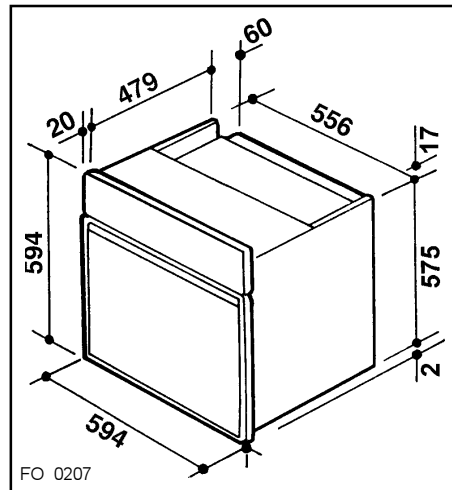

Securing The Oven To The Cabinet

1. Fit the oven into the cabinet recess,
2. Open the oven door
3. Secure the oven to the kitchen cabinet with four wood screws, which fit the holes provided in the oven frame.

