

Intel Express
100BASE-T4 Stackable Hub
User Guide

First edition August 1996
Second edition December 1996

Copyright © 1996, Intel Corporation. All rights reserved.
Intel Corporation, 5200 NE Elam Young Parkway, Hillsboro OR 97124-6497

Intel Corporation assumes no responsibility for errors or omissions in this manual. Nor does Intel make any commitment to update the information contained herein.

* Other product and corporate names may be trademarks of other companies and are used only for explanation and to the owners' benefit, without intent to infringe.

Contents

Quick Start	1
Chapter 1 Overview	3
Features	3
Physical Description	4
Chapter 2 Installing the Express Hub	9
Requirements	9
Installing a Single Hub	10
Stacking Hubs	11
Removing a Hub from a Stack	12
Installing Uplink Modules	12
Adding a Network Management Module (NMM)	13
Chapter 3 Connecting the Devices	15
Connecting Cables to the Hub	15
Checking the LEDs	16
Unit Numbering Convention	18
Partitioned Ports	18
Using a Switch to Connect Hubs	19
Connecting to Non-100BASE-T4 devices	20
Appendix A Fast Ethernet Topology Rules	23
Physical Layer Media Specifications	23
Basic Rules	24
Network Topology Extensions	26
Appendix B Optional Equipment and Technical Specifications	29
Optional Equipment	29
Technical Specifications	31
Limited Warranty	36

Index	37
Customer Support	Inside back cover

Quick Start

1 Install the hub(s).



- Maximum stack: Six hubs
- Rack requirements: Standard 19-in (48.26 cm), 1.5 EIA rack-mount space for each hub
- Shelf requirements: Support for 10 lbs (4.5 kg) per hub
12.3 lbs (5.6 kg) with uplink module and NMM

2 Connect the stack.

Use the cascade cables to connect multiple hubs. You need to purchase cascade cables separately from your network services supplier (see Appendix B for more information). **Do not use UTP cabling to connect hubs.**

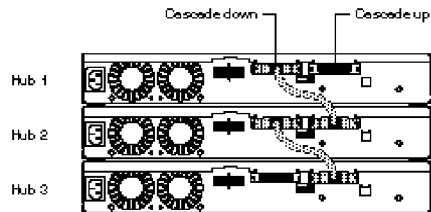

3 Connect the devices.

Connect 100BASE-T4 devices to the hub using four-pair Category 3, 4, or 5 unshielded twisted pair (UTP) cabling. Maximum cable distance between a port and an attached device is 100 meters.



4 Plug power cords into each hub, then check LEDs.

- Make sure the Pwr LED is lit for all hubs.
- Make sure the numbered port LEDs are lit for connected devices.

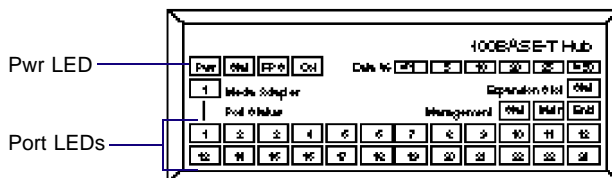

1

Overview

This chapter includes a summary of the Intel Express 100BASE-T4 Stackable Hub's features and a physical description of the hub and its components.

Features

Key features of the Intel Express 100BASE-T4 Stackable Hub

- Compatibility with the IEEE 802.3u standard for Fast Ethernet.
- Twelve 100BASE-T4 fixed ports.
- Uplink path to 100BASE-TX or 100BASE-FX devices via optional uplink modules.
- Hub management through the optional Network Management Module (NMM).
- Support for 4-pair Category 3, 4, or 5 UTP cabling.

Physical Description

Front panel

The front panel of the Express Stackable Hub provides twelve 100BASE-T4 ports, an LED matrix (see “LED matrix” later in this chapter for a description of LEDs), a media adapter slot, and an expansion slot.

Media adapter slot
for uplink modules
Expansion slot
for NMM

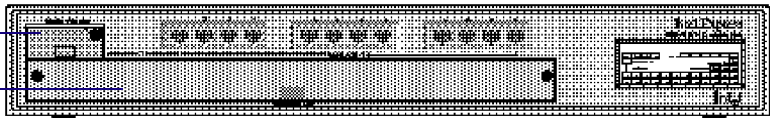

RJ-45 100BASE-T4 ports

NOTE

If you include Intel Express 100BASE-TX and 100BASE-T4 Stackable Hubs in the same stack, make sure you attach only the appropriate devices (TX or T4) to each type of hub.

The twelve 100BASE-T4 ports with fixed RJ-45 connectors allow you to connect to 100BASE-T4 network devices. You can use 4-pair Category 3, 4, or 5 unshielded twisted-pair (UTP) cable.

The maximum cable distance between the port and the attached device is 100 meters (328 feet), including all patch cables, panels, and connectors.

The following table lists the pinouts and pin pairings for a 100BASE-T4 hub and a server or workstation.

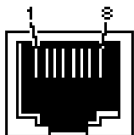

RJ-45 port

Workstation or server	Hub
1 (TX+)	1 (RX+)
2 (TX-)	2 (RX-)
3 (RX+)	3 (TX+)
6 (RX-)	6 (TX-)
4 Bidirectional (BD4+)	4 Bidirectional (BD4+)
5 Bidirectional (BD4-)	5 Bidirectional (BD4-)
7 Bidirectional (BD3+)	7 Bidirectional (BD3+)
8 Bidirectional (BD3-)	8 Bidirectional (BD3-)

LED matrix

The LED matrix on the Express Stackable Hub's front panel allows you to view the hub's operational status, collisions, network utilization, NMM status, and port status.

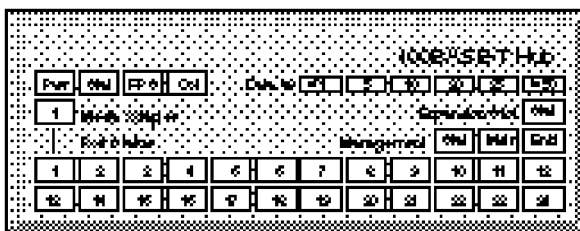

The following table describes the LEDs on the matrix.

Label	Type	Color	Meaning
Pwr	Hub power supply status	Green	Hub is receiving power.
		Off	Hub is not receiving power.
Stat	Hub status	Green	Hub has power, has passed the confidence test, and is operating normally.
		Amber	At initial power up, indicates the hub is running its confidence test. If this LED lights after the confidence test is performed, the hub is not operating normally due to a fan failure, a power supply failure, or a confidence test failure.
		Off	Hub is not receiving power.
RPS	Not supported	N/A	N/A
Col	Collision status	Amber	A collision was detected on the segment.
		Off	Collisions are not detected on the segment.

Label	Type	Color	Meaning
Data %	Network utilization	Green	Dynamically indicates the percentage of network utilization for the Ethernet segment in a hub or a stack of hubs. Operates as a bar graph. For example, if the ≤1% and 5% Data LEDs are green, that stack's segment is using roughly 5% of the network.
1 Media Adapter	Uplink module status	Green	An uplink module is installed in the media adapter slot, link status is good, and the port is not partitioned (disabled).
		Amber	Link status is good, but port is partitioned.
		Off	Link status is not detected.
Expansion Slot Stat	Expansion slot module status	Green	The module in the expansion slot passed the confidence test and is operating normally.
		Amber	The module in the expansion slot failed.
		Off	There is no module installed in the expansion slot.
Stat	Management status	Green	The NMM passed the confidence test and is operating normally.
		Amber	The NMM failed.
Mstr	Management status	Green	The NMM installed in the hub is the master NMM for that stack of hubs.
		Off	The NMM installed in the hub is not the master NMM for that stack of hubs.
Enbl	Management status	Green	The hub is properly connected to the other hubs in the stack and is actively managed by an NMM.
		Off	The hub is not managed by an NMM.
Port Status 1 — 12 13 — 24	Port status (hub ports) (not used)	Green	Link status is good; port is not partitioned.
		Amber	Link status is good; port is partitioned.
		Off	No link detected.

Rear panel

The rear panel of the Express Stackable Hub provides an AC power receptacle, a redundant power connector (not supported), and two cascade cable connectors.

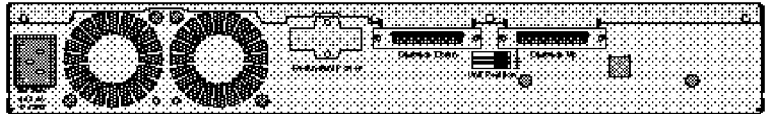

Power receptacle

The AC power receptacle is provided for connecting to an AC power outlet. The Express Stackable Hub accepts between 100 and 240V AC.

Cascade connectors

The Cascade Down and Cascade Up connectors and an Intel cascade cable allow you to stack and link multiple Express Stackable Hubs to increase the size of a particular workgroup in your network. The cascade cable connects to the Cascade Down connector on the top hub and the Cascade Up connector on the hub below it.

NOTE

A stack of Express Stackable Hubs can contain a maximum of six hubs.

NOTE

If you include Intel Express 100BASE-TX and 100BASE-T4 Stackable Hubs in the same stack, make sure you attach only the appropriate devices (TX or T4) to each type of hub.

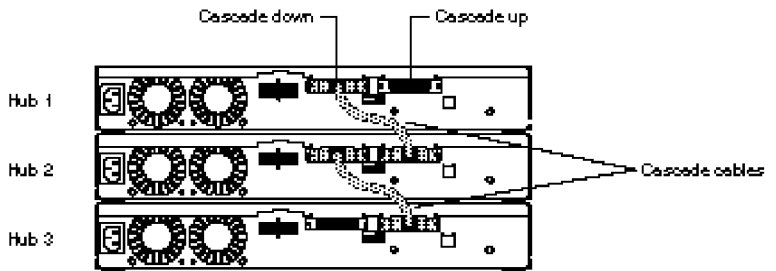

Optional equipment

The Intel 100BASE-T4 Stackable Hub ships with filler panels installed in the media adapter and expansion slots. Both panels can be removed to accommodate optional modules.

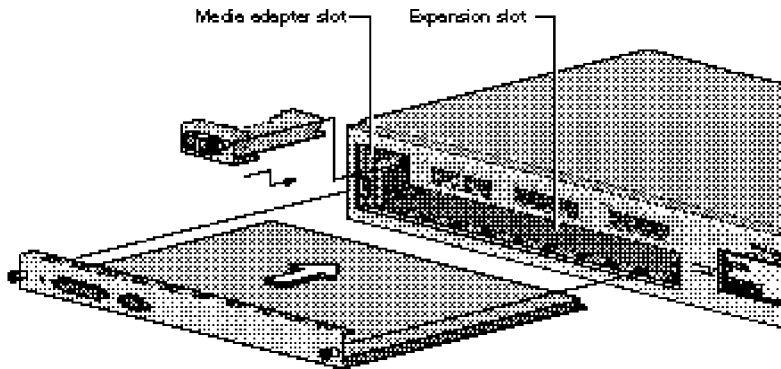

Media adapter slot

NOTE

Port 1 is disabled when the media adapter slot is filled.

The media adapter slot is located in the upper-left corner of the Express 100BASE-T4 Stackable Hub and accommodates two types of optional 100 Mbps uplink module:

- 100BASE-TX uplink module
- 100BASE-FX uplink module

Uplink modules allow you to connect to other 100 Mbps network devices using a different media.

For information about these modules, see “Optional Equipment” in Appendix B.

Expansion slot

NOTE

The Express 100BASE-T4 Stackable Hub does not support the 100BASE-TX 12-port expansion module.

The expansion slot is located in the lower half of the Express 100BASE-T4 Stackable Hub and accommodates an optional Express Stackable Hub Network Management Module (NMM).

For information about the NMM, see “Optional Equipment” in Appendix B.

2

Installing the Express Hub

Requirements

Rack installation requirements	Standard 19-in. (48.26 cm.) EIA equipment rack 1.5 EIA rack-mount spaces available for each hub
Table and shelf installation requirements	Approximately 13.25-in. (33.66 cm.) by 19.25-in. (48.90 cm.) area on a level tabletop or shelf Support for at least 10 lbs. (4.5 kg.) per hub with filler panels installed in expansion and media adapter slots Support for at least 12.3 lbs. (5.6 kg.) per hub with an NMM and an uplink module installed
Temperature	Ambient temperature between 5° C and 40° C (41° F and 104° F) No nearby heat sources such as direct sunlight, warm air exhausts, or heaters
Humidity	Between 5% and 85%, noncondensing
Ventilation	Minimum 2 in. (5.08 cm.) on all sides for cooling and adequate airflow in room or wiring closet
Operating conditions	At least 6 ft. (1.83 m.) from nearest source of electromagnetic noise (such as a photocopier)
Service access	Minimum 12 in. (30.48 cm.) front and rear for AC disconnect, service access and maintenance access Front and rear clearance for cables and wiring hardware such as punchdown blocks
Wiring hardware	Wiring hardware, such as punchdown blocks or patch panels, in place before installing the hub
Power	Adequate power source within 6 ft. (1.83 m.)

Installing a Single Hub

NOTE

Only qualified technicians should install and maintain this equipment.

To install the hub in a rack

- 1 Attach the mounting brackets to the sides of the hub.
- 2 Align the mounting holes in the brackets with the holes in the rack.
- 3 Insert two pan-head screws with nylon washers through each mounting bracket and into the rack.

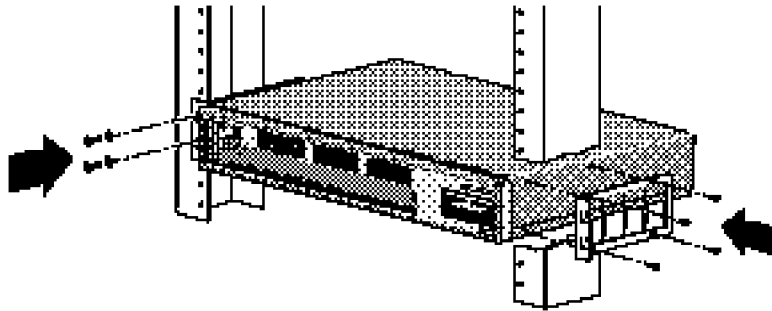

CAUTION

The power cord is a North American type, UL-listed/CSA-certified power supply cord. Discard this cord if it's inappropriate for the electrical system of your country, and get the cord required by your national electrical codes or ordinances and certified for use in your region.

- 4 Connect the AC power cord to the hub and then to the wall outlet or power strip.

To install the hub on a table or shelf

When installing a hub on a table or shelf, place the self-adhesive feet on the bottom of the hub.



CAUTION

Don't connect the power cord to a hub until all hubs are installed, connected together through cascade cables, and ready for operation.

Stacking Hubs

NOTE

If you include Intel Express 100BASE-TX and 100BASE-T4 Stackable Hubs in the same stack, make sure you attach only the appropriate devices (TX or T4) to each type of hub.

You can install a maximum of six hubs in an equipment rack or on a shelf or a table. Once the hubs are stacked and secured, connect them using Intel cascade cables. The cascade cable is a unique cable for Express Stackable Hubs.

If you install an optional Network Management Module (NMM), it assigns unit numbers starting from the top of the stack. Position the hub you want to designate number 1 at the top of the stack.

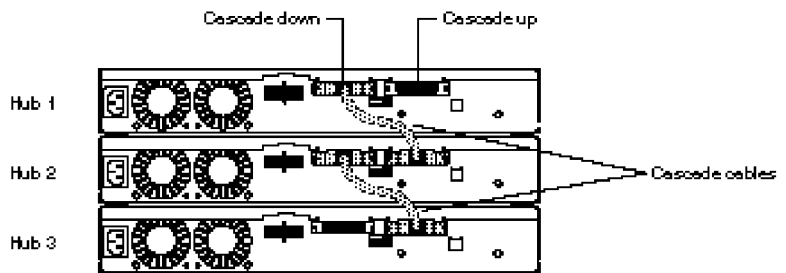

Notes on cascading

NOTE

Use Intel cascade cables to connect Express Stackable Hubs. Do not use UTP cabling to connect hubs.

A stack of hubs functions as a single repeater or collision domain. The cascade cables form a cascade bus that carries the following information to each hub in the stack:

- Stack management information that allows one NMM to manage every hub in a stack.
- Port statistics that distribute configuration and status information for each port in the stack to an NMM and network management system.
- Daisy chain unit number information that provides a sequential numbering convention for a stack of up to six hubs. For information about the unit numbering convention, see “Unit Numbering Convention” in Chapter 3.
- Network data.

Removing a Hub from a Stack

CAUTION

When you remove a hub from the middle of the stack (any hub located between two operating hubs) and don't reattach the cascade cables, you split the Ethernet segment into two separate segments.

CAUTION

Check that the screw locks on the cable connectors are fully tightened and the cable connection is secure. A faulty cable connection could disrupt the operation of the entire stack.

To remove the hub from a rack

- 1 Disconnect power to the hub by unplugging the power cable.
- 2 Disconnect the appropriate cascade cables.
- 3 Use a #2 Phillips screwdriver to loosen the screws that secure each mounting bracket to the rack.
- 4 Remove the screws from the mounting bracket while supporting the bottom of the hub, then carefully remove the hub from the rack.

To remove the hub from a stack that is mounted on a table or shelf

Gently lift any hubs stacked on top of the hub you want to remove, then carefully remove that hub from the stack.

After you've removed the hub from the stack, connect the free end of the cascade cable connected to the Cascade Down connector on the top hub to the Cascade Up connector on the bottom hub.

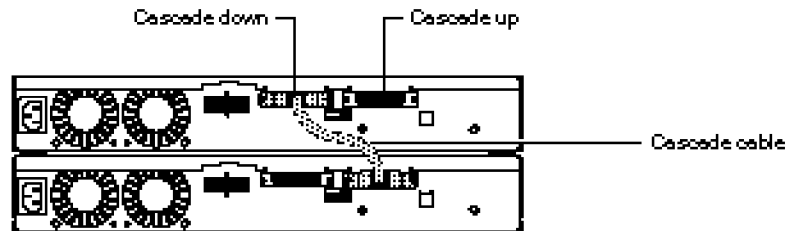

Installing Uplink Modules

NOTE

When you install an uplink module in the hub's media adapter slot, port 1 is disabled.

You can install an optional 100BASE-TX or 100BASE-FX uplink module in the media adapter slot. Install these modules before connecting power to the hub. If you install these modules when the hub is powered, the hub may reset, temporarily suspending port connectivity in the hub.

For more information on installing uplink modules, see the documentation that ships with the modules.

Adding a Network Management Module (NMM)

After powering down the hub, install the NMM in the hub at the top of your stack. When an NMM is installed in the stack, it automatically numbers the hubs in the stack. After you install the NMM and reconnect the power cord, the entire stack of hubs resets, and you temporarily lose port connectivity to each hub.

For more information on installing the NMM, see the *Express Stackable Hub Network Management Module User Guide*.

3

Connecting the Devices

Connecting Cables to the Hub

NOTE

Make sure your network conforms to the Fast Ethernet rules described in Appendix A.

Connect devices directly to ports on the Express 100BASE-T4 Stackable Hub or to ports on installed uplink modules. This illustration shows how to connect a UTP cable to an RJ-45 connector and a fiber optic cable to an SC connector.



UTP cable connection to RJ-45 port

Fiber optic cable connection to SC port

PO-2228

NOTE

100BASE-T4 devices use 4-pair Category 3, 4, or 5 UTP cabling. 100BASE-TX devices use 2-pair Category 5 UTP cabling.

If your stack combines Intel Express 100BASE-TX and 100BASE-T4 Stackable Hubs, make sure you attach the appropriate device (TX or T4) to each type of hub. If you attach the wrong type of device to a hub, that device won't function properly, and the hub may malfunction.

You can connect the following 100 Mbps devices to the ports on the Express Stackable Hub and optional uplink modules:

- Workstations
- Servers
- Printers
- Transceivers
- Switching hubs
- Routers
- Printers
- Print servers

See “Using a switch to connect hubs” later in this chapter for information about connecting to 100 Mbps switching hubs. For information about making connections to other 100BASE-T4 devices, refer to the documentation that shipped with the device.

Checking the LEDs

When you connect the power cord to the Express 100BASE-T4 Stackable Hub, the hub performs a confidence test. During this test, the hub’s Stat LED lights amber to indicate the test is in progress.

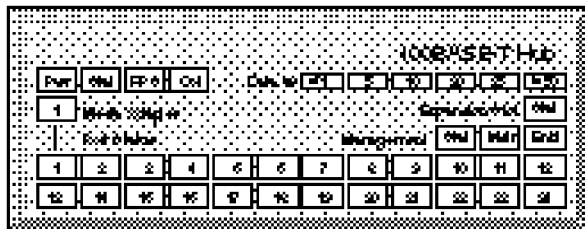

When the confidence test successfully completes, the LEDs on the hub’s front panel should appear as follows:

- The Pwr LED lights green, indicating the hub is receiving power.
- The Stat LED lights green, indicating the hub passed the confidence test and is operating normally.

- The Data % LEDs light green on each hub, indicating the overall network utilization percentage of the Ethernet segment. Because a stack of hubs is a single segment, utilization is the same for each hub in the stack.
- If an optional uplink module is installed in the media adapter slot, the appropriate cable is connected to the media adapter port, and the link status is good, the Media Adapter LED lights green. When this LED is on, port 1 on the hub is disabled.
- If an NMM is installed in the expansion slot, the Enbl LEDs on each hub in the stack light green, indicating the hub is properly connected to the other hubs in the stack and is actively managed by an NMM.
- If an NMM is installed in the expansion slot, the Management LEDs light as follows:
 - The Stat LED lights green, indicating the NMM passed the confidence test and is operating normally.
 - The Mstr LED lights green, indicating the NMM is the master NMM in the stack.
- A Port Status LED for each port on the hub provides port status.

LED	Color	Status indications
Hub ports 1–12	Green	Link is good, port is not partitioned (disabled).
	Amber	Link is good, port is partitioned.
	Off	Link is not detected.

Unit Numbering Convention

NOTE

A stack of Express Stackable Hubs can contain a maximum of six hubs.

When Express Hubs are stacked, cascaded, and powered, they are assigned “unit” numbers that are stored in the hub’s nonvolatile memory. Hub numbers are assigned according to a hub’s physical location in the stack. The NMM assigns numbers from the top down—the hub at the top of the stack is numbered 1, the hub below hub 1 is numbered 2, and so on.

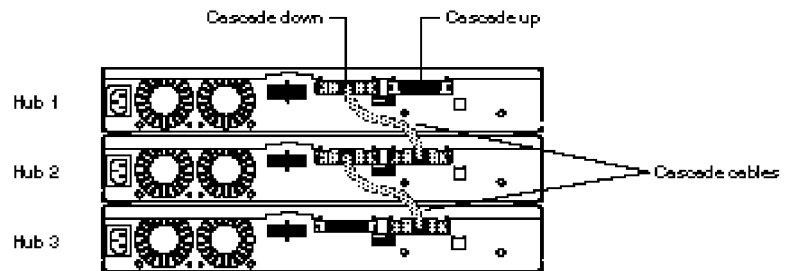

In a fully equipped stack, hubs are assigned numbers 1 through 6. You can identify the unit numbers of the hubs in the stack using network management software such as Intel LANDesk® Network Manager.

As you build your stack to include more hubs, each hub you add is assigned a unit number according to its position in the stack after the NMM is reset or the stack is renumbered through network management software.

Partitioned Ports

When the Express Stackable Hub detects a large number of consecutive collisions on a port, it automatically disables, or partitions, that port. These collisions often occur due to excessive traffic or a malfunctioning port or network adapter. After the problem is corrected, the port is automatically re-enabled.

Using a Switch to Connect Hubs

Integrating switching into the network enables network segmentation, which increases the total capacity and performance. You can add 100 Mbps workgroups to the network and connect them to individual ports on a Fast Ethernet switch.

The illustration below shows how Express Stackable Hubs interface with a switching hub to increase the total capacity and performance of an entire network.

Three groups of 100 Mbps workstations are connected to three separate hub stacks. The Express Hubs are stacked to provide multiple ports per stack. This network shows three hub stacks that support individual workgroups.

A 100BASE-FX uplink module is installed in one of the Express Hubs, connecting the hub stack to the switching hub through a 100 Mbps fiber link. Two servers equipped with 100 Mbps LAN adapters are connected to the switch to provide centralized services to workstations in all three workgroups.

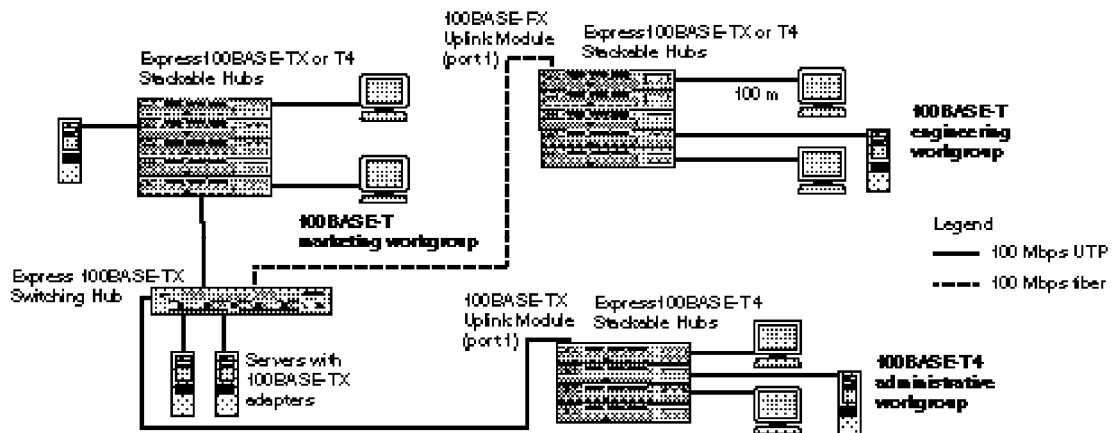

Connecting to Non-100BASE-T4 devices

Connecting to 100BASE-TX devices

You have two options for connecting the Express 100BASE-T4 Stackable Hub to a 100BASE-TX device:

- an Intel 100BASE-TX Uplink Module
- a routing server equipped with a 100BASE-T4 NIC and a 100BASE-TX NIC

You can also use Intel cascade cables to combine Express 100BASE-TX Stackable Hubs with Express 100BASE-T4 Stackable hubs in a stack. If you're using a combined stack, make sure you attach the appropriate device (TX or T4) to each type of hub. If you attach the wrong type of device to a hub, that device won't function properly, and the hub may malfunction.

100BASE-TX Uplink Module

NOTE

Port 1 on a hub is disabled when an uplink module is installed.

Intel's 100BASE-TX Uplink Module fits in the hub's media adapter slot and allows you to connect to 100BASE-TX devices using Category 5 UTP cabling.

For more information on the 100BASE-TX Uplink Module, see Appendix B.

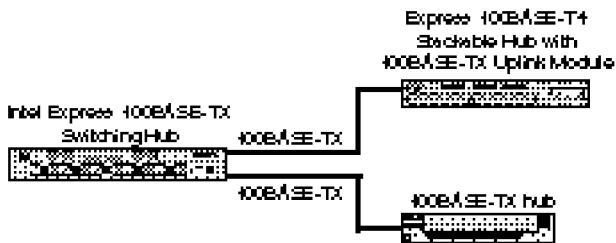

Routing server

If you're using a NOS that supports multi-protocol routing, such as Novell NetWare® or Windows NT®, an inexpensive way to connect the 100BASE-T4 and 100BASE-TX segments is to install both a 100BASE-T4 and 100BASE-TX LAN adapter in your server and let the server bridge the segments.

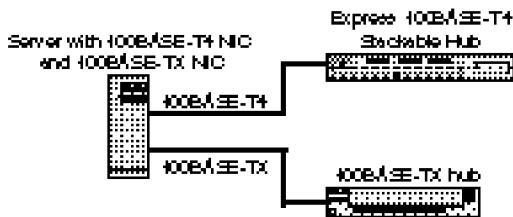

Connecting to 100BASE-FX devices

NOTE

Port 1 on a hub is disabled when an uplink module is installed.

To connect the Express 100BASE-T4 Stackable Hub to a 100BASE-FX device, use an Intel 100BASE-FX Uplink Module. The 100BASE-FX Uplink Module fits in the hub's media adapter slot and allows you to connect to 100BASE-FX devices.

For more information on the 100BASE-FX Uplink Module, see Appendix B.

Connecting to 10BASE-T devices

NOTE

You cannot connect a 10BASE-T device directly to the Express Stackable Hub.

You have three options for connecting the Express 100BASE-T4 Stackable Hub to 10BASE-T devices:

- a 100BASE-TX Uplink Module and an Express 10/100 Downlink.
- a 100BASE-TX Uplink Module and a 10/100 switching hub.
- a routing server equipped with a 100BASE-T4 NIC and a 10BASE-T NIC.

100BASE-TX Uplink Module and 10/100 Downlink

NOTE
Port 1 on a hub is disabled when an uplink module is installed.

Intel's 100BASE-TX Uplink Module fits in the hub's media adapter slot and allows you to connect to 100BASE-TX devices, such as the Express 10/100 Downlink. The Express 10/100 Downlink allows you to connect to 10BASE-T devices.



100BASE-TX Uplink Module and 10/100 switching hub

You can also use the 100BASE-TX Uplink Module to connect to a 10/100 switching hub. The switching hub then bridges the 10 Mbps and 100 Mbps segments



Routing server

If you're using a NOS that supports multi-protocol routing, such as Novell NetWare or Windows NT, you can use a routing server equipped with a 100BASE-T4 NIC and a 10BASE-T NIC to bridge the 100BASE-T4 and 10BASE-T segments.

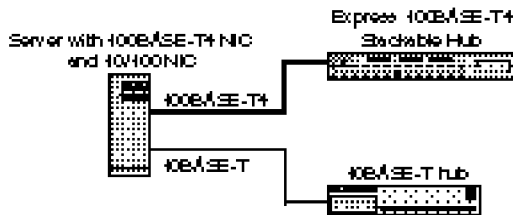



A

Fast Ethernet Topology Rules

This appendix describes

- 100BASE-T physical layer media specifications
- repeater rules

For a complete explanation of the set of 100BASE-T rules and guidelines, refer to the Institute of Electrical and Electronics Engineers (IEEE) 100BASE-T 802.3u standard.

For information about cables for Ethernet networks, refer to the Electronic Industries Association/Telecommunications Industry Association (EIA/TIA) wiring standard EIA/TIA 568.

Physical Layer Media Specifications

Three media specifications are associated with 100BASE-T:

- 100BASE-TX
- 100BASE-FX
- 100BASE-T4

The following table lists the cable and connector types and the coding scheme that each media specification uses.

Media specification	Cable type(s)	Connector type(s)	Coding scheme
100BASE-T4	CAT 3, 4, 5 UTP (4-pair wire)	RJ-45	8B/6T
100BASE-TX	CAT 5 UTP (2-pair wire)	RJ-45	4B/5B
100BASE-FX	62.5/125 micron fiber optic cable (2 multi-mode fibers)	SC	4B/5B

Basic Rules

When deploying 100BASE-T4 Fast Ethernet, you should follow three basic rules:

- UTP cable length from repeater to workstation or switch can't exceed 100 meters (328 feet).
- Fiber cable length from repeater to workstation or switch can't exceed 131 meters (429 feet) .
- You can't use UTP cabling to connect Express Stackable Hubs to each other. Express Stackable Hubs are Class I repeaters and can be connected only with Intel Cascade Cables.

Distance limitations

100BASE-T4 and 100BASE-TX

The EIA/TIA 568 wiring standard specifies that UTP wiring must not exceed 100 meters (328 feet) from repeater to workstation or switch. This specification limits collision domain diameter to 200 meters (656 meters).

100BASE-T4 and 100BASE-FX

In a 100BASE-T4/100BASE-FX environment, the collision domain must not exceed 231 meters (757 feet)—100 meters T4 and 131 meters FX—in diameter.

Repeater rules

The 100BASE-T standard defines two types of repeaters — Class I and Class II. The Express Stackable Hub is a Class I repeater. Class I repeaters (sometimes called translational repeaters) limit the number of repeaters in a physical domain to one.

However, the one-repeater maximum for Class I repeaters does not limit the port density of 100BASE-T networks when stackable hubs are used. Express Stackable Hubs can be stacked to form a single, multi-port repeater where each repeater stack can be managed like a single repeater unit.

Class I repeaters cannot be daisy-chained (connected to one another using UTP cabling).

Network Topology Extensions

You can extend the network topology by connecting Express Stackable Hubs to a switching hub.

In the illustration below, the network topology is extended to a maximum of 400 meters (1312 feet). In this network, a switching hub interconnects two separate repeater stacks to form two separate collision domains. Since each UTP cable, from workstation to repeater and repeater to switch, does not exceed 100 meters (328 feet), the collision domains do not exceed 200 meters (656 feet) in diameter. Integrating the switch into the network to form two collision domains of 200 meters each extends the network topology to 400 meters.

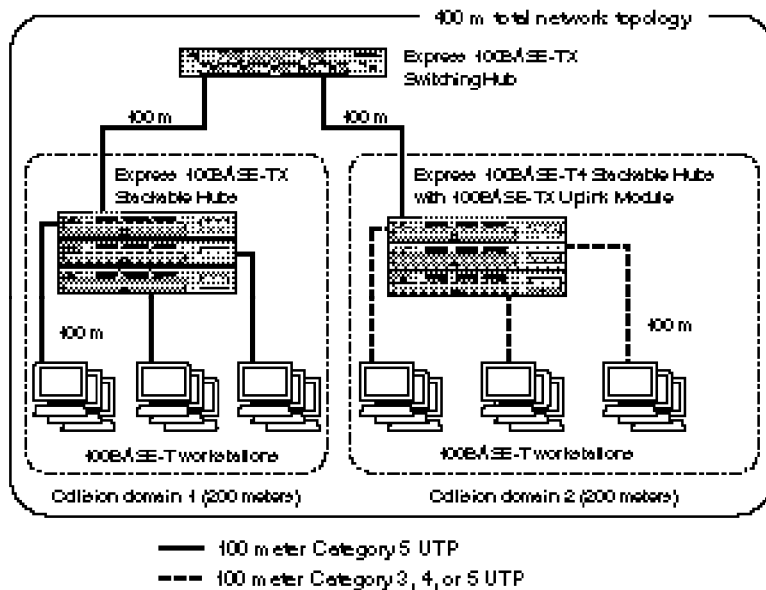

In the next illustration, the network topology is extended to a maximum distance of 491 meters (1610 feet). In this network, a 160 meter (524 feet) fiber link connects the 100BASE-TX repeater to the switch, and a 131 meter (429 feet) fiber link connects the 100BASE-T4 repeater to the switch. 100 meter (328 feet) Category 5 UTP wiring connects workstations and servers to the repeater stacks. The 100BASE-TX collision domain is 260 meters (852 feet), and the 100BASE-T4 collision domain is 231 meters (757 feet). When the two collision domains are interconnected through the switch, the network topology is extended to a total of 491 meters.

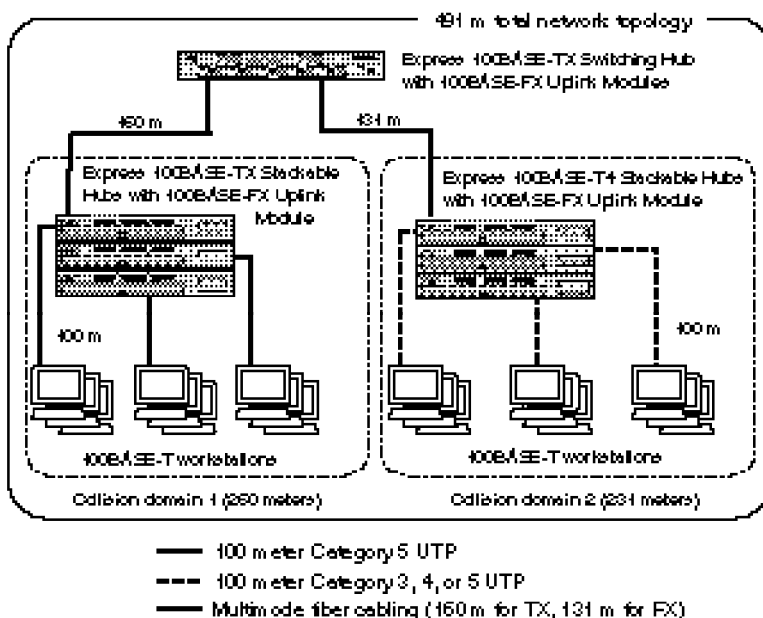

If you're using a 100BASE-FX Uplink Module in a 100BASE-T4 stackable hub, fiber cable length is limited to 131 meters. If you're using a 100BASE-FX Uplink Module in a 100BASE-TX stackable hub, fiber cable length is limited to 160 meters. If a stack combines 100BASE-TX hubs and 100BASE T4 hubs, fiber distance is limited to 131 meters.

You can extend the 100BASE-T network topology further by interconnecting the switches using fiber links. Interconnecting two switches creates a network that contains four separate collision domains. The overall network topology grows while each collision domain can be modeled after the extended collision domains shown in the previous two illustrations.

The next illustration shows how two separate 100BASE-T networks, each supporting different workgroups in different physical locations, are interconnected using a 2-km fiber link.

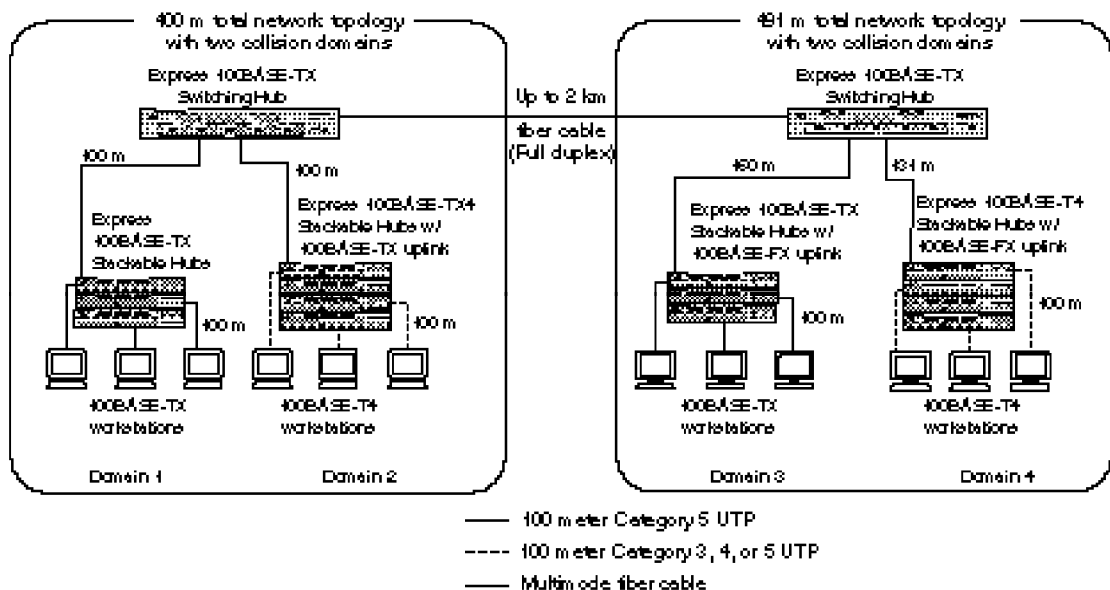

B

Optional Equipment and Technical Specifications

This appendix describes optional equipment supported by the Express 100BASE-T4 Stackable Hub and provides technical specifications for the hub.

Optional Equipment

Uplink modules

The 100BASE-TX and 100BASE-FX uplink modules fit into the media adapter slot and provide a connection to other 100 Mbps equipment in your network.

The Intel 100BASE-TX Uplink Module (Intel product code EC100MATX) provides a standard RJ-45 connector for Category 5 UTP cable. The maximum distance between the port and the attached 100BASE-TX device is 100 meters (including all patch cables, panels, and connectors).

The Intel 100BASE-FX Uplink Module (Intel product code EC100MAFX) provides a standard SC connector for 62.5/125 μm multimode fiber optic cable. The maximum distance between the uplink port and the attached 100BASE-FX device is 131 meters (including all patch cables, panels, and connectors).

Network Management Module (NMM)

The Intel Express Stackable Hub Network Management Module (Intel product code EC100NMM) fits into the expansion slot and allows you to extend per-port advanced Simple Network Management Protocol (SNMP) management functions to each Express Stackable Hub in the stack.

Advanced SNMP management allows you to communicate with SNMP-compatible software to

- monitor network statistics and view errors and hardware status.
- view configuration and status information for each port in a stack of up to six hubs.
- gather network communications and activities information for analysis and storage.

The advanced level of network management also supports Intel LANDesk Network Manager. The NMM agent software contains embedded management features that allow you to get important information from existing nodes.

Cascade cables

Intel cascade cables (Intel product code EC100CC) allow you to stack and link multiple Express Stackable Hubs so you can expand port connections in a network segment. A stack can contain a maximum of six hubs. When connected using Intel cascade cables, the entire stack of hubs acts as a single repeater or collision domain.

Technical Specifications

Network Protocol and Standards Compatibility

IEEE 802.3u 100BASE-T

Data Rate

T4: 100 Mbps with 8B/6T coding scheme

TX: 100 Mbps with 4B/5B coding scheme

FX: 100 Mbps with 4B/5B coding scheme

Electrical Specifications

Input power: 160 W

Thermal rating: 550 BTU/hr

AC line frequency: 47–63 Hz

Input voltage (rms): 90–264 V AC

Volt amperes rating: 250 VA

Physical Specifications

Dimensions: 11.18 (l) by 17.25 (w) by 2.57 (h) in.
 28.40 (l) by 43.82 (w) by 6.53 (h) cm.

Weight: 10.0 lbs (4.5 kg) with filler panels installed
 12.3 lbs (5.6 kg) with an NMM and a media adapter
 installed (optional equipment)

Environmental Specifications

Operating temperature: 5° to 40° C

Storage temperature: –25° to 70° C

Operating humidity: 85% maximum relative humidity,
 noncondensing

Storage humidity: 95% maximum relative humidity,
 noncondensing

Operating altitude: 10,000 ft (3,000 m) maximum

Storage altitude: 10,000 ft (3,000 m) maximum

Safety Agency Approvals

UL listed (UL 1950) Third Edition

UL listed for Canada

TUV certified to IEC 950 Second Edition plus A1/A2 and EN60950
A1/A2

Repeater Type

① Class I repeater

Interface Options

RJ-45 connectors for 4-pair Category 3, 4, or 5 UTP
100BASE-T4 Ethernet interface

RJ-45 connectors for 2-pair Category 5 UTP 100BASE-TX Ethernet
interface with installed 100BASE-TX uplink module

Fiber optic SC connectors for 100BASE-FX Ethernet interface with
installed 100BASE-FX uplink module

Notice

For 120-volt operation, use only with power cord having a parallel
blade, grounding type attachment plug, rated 10 amp, 125 volts.

For 240-volt operation, use only with power cord having a tandem
blade, grounding type attachment plug, rated 10 amp, 250 volts.

Statement of Conditions

In the interest of improving internal design, operational function, or reliability, Intel Corp. reserves the right to make changes to the products described in this document without notice.

Intel Corp. does not assume any liability that may occur due to the use or application of the products or circuit layouts described herein.

Electromagnetic Emissions

Meets requirements of FCC Part 15, Subpart B, Class A, EN 55 022 (CISPR 22:1985), Class A, and VCCI Class 1 ITE

Electromagnetic Susceptibility

Electrostatic discharge (ESD): IEC 801-2, Electromagnetic susceptibility: IEC 801-3, Electrical fast transient/burst: IEC 801-4

Federal Communications Commission (FCC) Statement

Note: This equipment has been tested and found to comply with the limits for a Class A digital device, pursuant to Part 15 of the FCC rules. These limits are designed to provide reasonable protection against harmful interference when the equipment is operated in a commercial environment. This equipment generates, uses, and can radiate radio frequency energy. If it is not installed and used in accordance with the instruction manual, it may cause harmful interference to radio communications. Operation of this equipment in a residential area is likely to cause harmful interference, in which case users will be required to take whatever measures may be necessary to correct the interference at their own expense.

Manufacturer Declaration

We certify that this product is in compliance with EU directive 89/336/EEC, using the EMC standards EN55022 and EN50082-1. This product also meets or exceeds EN60950 safety requirements.

This product has been tested and verified to meet CISPR 22 Class A requirements.

Voluntary Control Council for Interference (VCCI) Statement

この装置は、第一種情報装置（商工業地域において使用されるべき情報装置）で、商工業地域での電波障害防止を目的とした情報処理装置等電波障害自主規制協議会（VCCI）基準に適合しております。

従って、住宅地域、その隣接地域等で使用した場合、ラジオ、テレビ受信機等に障害を与えることがあります。

上記基準に適合する遮蔽ケーブルを使用し、取扱説明書に従って、正しくご使用ください。

This equipment is in the Class 1 category (information equipment to be used in commercial and/or industrial areas) and conforms to the standards set by the Voluntary Control Council for Interference by Data Processing Equipment and Electronic Office Machines that are aimed at preventing radio interference in commercial and/or industrial areas.

Consequently, when this equipment is used in a residential area or in an adjacent area thereto, radio interference may be caused to equipment such as radios and TV receivers.

Compliance with the applicable regulations is dependent upon the use of shielded cables. The user is responsible for procuring the appropriate cables. Read instructions for correct handling.

WARNING

This is a Class A product. In a domestic environment this product may cause radio interference in which case the user may be required to take adequate measures.

WARNING

The system is designed to operate in a typical office environment. Choose a site that is:

- Clean and free of airborne particles (other than normal room dust).
- Well ventilated and away from sources of heat including direct sunlight.
- Away from sources of vibration or physical shock.
- Isolated from strong electromagnetic fields produced by electrical devices.
- In regions that are susceptible to electrical storms, we recommend you plug your system into a surge suppressor and disconnect telecommunication lines to your modem during an electrical storm.
- Provided with a properly grounded wall outlet.

Do not attempt to modify or use the supplied AC power cord if it is not the exact type required.

Ensure that the system is disconnected from its power source and from all telecommunications links, networks, or modems lines whenever the chassis cover is to be removed. Do not operate the system with the cover removed.

AVERTISSEMENT

Le système a été conçu pour fonctionner dans un cadre de travail normal. L'emplacement choisi doit être:

- Propre et dépourvu de poussière en suspension (sauf la poussière normale).
- Bien aéré et loin des sources de chaleur, y compris du soleil direct.
- A l'abri des chocs et des sources de vibrations.
- Isolé de forts champs magnétiques générés par des appareils électriques.
- Dans les régions sujettes aux orages magnétiques il est recommandé de brancher votre système à un supresseur de surtension, et de débrancher toutes les lignes de télécommunications de votre modem durant un orage.
- Muni d'une prise murale correctement mise à la terre.

Ne pas utiliser ni modifier le câble d'alimentation C. A. fourni, s'il ne correspond pas exactement au type requis.

Assurez vous que le système soit débranché de son alimentation ainsi que de toutes les liaisons de télécommunication, des réseaux, et des lignes de modem avant d'enlever le capot. Ne pas utiliser le système quand le capot est enlevé.

WARNUNG

Das System wurde für den Betrieb in einer normalen Büroumgebung entwickelt. Der Standort sollte:

- sauber und staubfrei sein (Hausstaub ausgenommen);
- gut gelüftet und keinen Heizquellen ausgesetzt sein (einschließlich direkter Sonneneinstrahlung);
- keinen Erschütterungen ausgesetzt sein;
- keine starken, von elektrischen Geräten erzeugten elektromagnetischen Felder aufweisen;
- in Regionen, in denen elektrische Stürme auftreten, mit einem Überspannungsschutzgerät verbunden sein; während eines elektrischen Sturms sollte keine Verbindung der Telekommunikationsleitungen mit dem Modem bestehen;
- mit einer geerdeten Wechselstromsteckdose ausgerüstet sein.

Versuchen Sie nicht, das mitgelieferte Netzkabel zu ändern oder zu verwenden, wenn es sich nicht um genau den erforderlichen Typ handelt.

Das System darf weder an eine Stromquelle angeschlossen sein noch eine Verbindung mit einer Telekommunikationseinrichtung, einem Netzwerk oder einer Modem-Leitung haben, wenn die Gehäuseabdeckung entfernt wird. Nehmen Sie das System nicht ohne die Abdeckung in Betrieb.

AVVERTENZA

Il sistema è progettato per funzionare in un ambiente di lavoro tipico. Scegliere una postazione che sia:

- Pulita e libera da particelle in sospensione (a parte la normale polvere presente nell'ambiente).
- Ben ventilata e lontana da fonti di calore, compresa la luce solare diretta.
- Al riparo da urti e lontana da fonti di vibrazione.
- Isolata dai forti campi magnetici prodotti da dispositivi elettrici.
- In aree soggette a temporali, è consigliabile collegare il sistema ad un limitatore di corrente. In caso di temporali, scollegare le linee di comunicazione dal modem.
- Dotata di una presa a muro correttamente installata.

Non modificare o utilizzare il cavo di alimentazione in c. a. fornito dal produttore, se non corrisponde esattamente al tipo richiesto.

Prima di rimuovere il coperchio del telaio, assicurarsi che il sistema sia scollegato dall'alimentazione, da tutti i collegamenti di comunicazione, reti o linee di modem. Non avviare il sistema senza aver prima messo a posto il coperchio.

ADVERTENCIAS

El sistema está diseñado para funcionar en un entorno de trabajo normal. Escoja un lugar:

- Limpio y libre de partículas en suspensión (salvo el polvo normal)
- Bien ventilado y alejado de fuentes de calor, incluida la luz solar directa.
- Alejado de fuentes de vibración.
- Aislado de campos electromagnéticos fuertes producidos por dispositivos eléctricos.
- En regiones con frecuentes tormentas eléctricas, se recomienda conectar su sistema a un eliminador de sobrevoltage y desconectar el módem de las líneas de telecomunicación durante las tormentas.
- Previsto de una toma de tierra correctamente instalada.

No intente modificar ni usar el cable de alimentación de corriente alterna, si no se corresponde exactamente con el tipo requerido.

Asegúrese de que cada vez que se quite la cubierta del chasis, el sistema haya sido desconectado de la red de alimentación y de todos los enlaces de telecomunicaciones, de red y de líneas de módem. No ponga en funcionamiento el sistema mientras la cubierta esté quitada.

Limited Warranty

Intel warrants to the original owner that the product delivered in this package will be free from defects in material and workmanship for three (3) years following the latter of: (i) the date of purchase only if you register by returning the registration card as indicated thereon with proof of purchase; or (ii) the date of manufacture; or (iii) the registration date if by electronic means provided such registration occurs within 30 days from purchase. This warranty does not cover the product if it is damaged in the process of being installed. Intel recommends that you have the company from whom you purchased this product install the product.

INTEL RESERVES THE RIGHT TO FILL YOUR ORDER WITH A PRODUCT CONTAINING NEW OR REMANUFACTURED COMPONENTS. THE ABOVE WARRANTY IS IN LIEU OF ANY OTHER WARRANTY, WHETHER EXPRESS, IMPLIED OR STATUTORY, INCLUDING, BUT NOT LIMITED TO, ANY WARRANTY OF MERCHANTABILITY, FITNESS FOR A PARTICULAR PURPOSE, OR ANY WARRANTY ARISING OUT OF ANY PROPOSAL, SPECIFICATION OR SAMPLE.

This warranty does not cover replacement of products damaged by abuse, accident, misuse, neglect, alteration, repair, disaster, improper installation or improper testing. If the product is found to be otherwise defective, Intel, at its option, will replace or repair the product at no charge except as set forth below, provided that you deliver the product along with a return material authorization (RMA) number either to the company from whom you purchased it or to Intel (North America only). If you ship the product, you must assume the risk of damage or loss in transit. You must use the original container (or the equivalent) and pay the shipping charge. Intel may replace or repair the product with either new or remanufactured product or parts, and the returned product becomes Intel's property. Intel warrants the repaired or replaced product to be free from defects in material and workmanship for a period of the greater of: (i) ninety (90) days from the return shipping date; or (ii) the period of time remaining on the original three (3) year warranty.

This warranty gives you specific legal rights and you may have other rights which vary from state to state. All parts or components contained in this product are covered by Intel's limited warranty for this product.

Copyright © 1996 by Intel Corporation. All rights reserved. This document may not be reproduced in whole or in part without the express written permission of Intel Corporation.

Intel Corporation, 5200 NE Elam Young Parkway, Hillsboro OR 97124

Returning a defective product

From North America:

Before returning any product, contact Intel Customer Support and obtain a Return Material Authorization (RMA) number by calling +1 503 264-7000.

If the Customer Support Group verifies that the product is defective, they will have the RMA department issue you an RMA number to place on the outer package of the product. Intel cannot accept any product without an RMA number on the package.

All other locations:

Return the product to the place of purchase for a refund or replacement.

Limitation of liability and remedies

INTEL SHALL HAVE NO LIABILITY FOR ANY INDIRECT, SPECULATIVE, CONSEQUENTIAL, INCIDENTAL, PUNITIVE OR SPECIAL DAMAGES ARISING FROM THE USE OF OR INABILITY TO USE THIS PRODUCT INCLUDING, WITHOUT LIMITATION, LOSS OF USE, BUSINESS INTERRUPTIONS, LOSS OF PROFITS, AND LOSS OF GOODWILL, WHETHER ANY SUCH DAMAGES ARISE OUT OF CONTRACT NEGLIGENCE, TORT, OR UNDER ANY WARRANTY, IRRESPECTIVE OF WHETHER INTEL HAS ADVANCE NOTICE OF THE POSSIBILITY OF ANY SUCH DAMAGES. NOTWITHSTANDING THE FOREGOING, INTEL'S TOTAL LIABILITY FOR ALL CLAIMS UNDER THIS AGREEMENT SHALL NOT EXCEED THE PRICE PAID FOR THE PRODUCT. THESE LIMITATIONS ON POTENTIAL LIABILITIES WERE AN ESSENTIAL ELEMENT IN SETTING THE PRODUCT PRICE. INTEL NEITHER ASSUMES NOR AUTHORIZES ANYONE TO ASSUME FOR IT ANY OTHER LIABILITIES.

Some states do not allow the exclusion or limitation of incidental or consequential damages, so the above limitations may not apply to you.

Software provided with the hardware product is not covered under the hardware warranty described above. See the applicable software license agreement which shipped with the product for details on any software warranty.

April 1996

I

Index

1 Media Adapter LED
operating conditions 6
verifying installation 17

100BASE-FX
data rate 31
devices, connecting to 21
distance limitations 24, 27
media specification 24
uplink module 29

100BASE-FX Uplink Module
installation guidelines 12
using 21

100BASE-T
network topology extensions 26
switched LAN 19

100BASE-T4
data rate 31
distance limitations 24, 26
media specification 24

100BASE-T4 ports
connecting cables 15

100BASE-TX
data rate 31
devices, connecting to 20
media specification 24
uplink module 29

100BASE-TX Uplink Module
installation guidelines 12
using 20, 21

10BASE-T
devices, connecting to 21

A–C

AC line frequency 31

AC power receptacle
description 7
location 7

Altitude
operating and storage 31

Approvals
safety agency 32

Cables
connecting 15
length 24

Cascade cables
installation considerations 11
order codes 30

Cascade connectors 7

Class 1 repeaters 32

Class 2 repeaters 25

- Coding schemes
 - media specifications 24
- Col LED
 - operating conditions 5
- Confidence test 16
- Connecting
 - cables 15
 - to 100BASE-FX devices 21
 - to 100BASE-TX devices 20
 - to 10BASE-T devices 21
 - to non-100BASE-T4 devices 20
- Connecting hubs
 - using a switch 19
 - using cascade cables 11

D–F

- Data % (utilization) LED
 - operating conditions 6
 - verifying installation 17
- Data rate
 - 100BASE-FX 31
 - 100BASE-T4 31
 - 100BASE-TX 31
- Dimensions, physical 31
- Distance limitations
 - collision domain 24
 - fiber 24
 - UTP 24
- EIA/TIA 568 wiring standard 23
- Electrical specifications
 - AC line frequency 31
 - input power specification 31
 - input voltage 31
 - thermal rating 31
 - volt amperes rating 31
- Electromagnetic emissions 33
- Electromagnetic susceptibility 33
- Enbl LED
 - operating conditions 6
 - verifying installation 17
- Environmental specifications 31

- Ethernet segment
 - collision domain 26, 27
 - network utilization status 6, 17
- Expansion slot 8
- Expansion Slot Stat LED
 - operating conditions 6
- Express 10/100 Downlink
 - connecting to 21
- Fast Ethernet
 - basic rules 24
- Features 3
- Front panel features
 - Expansion slot 4
 - LED matrix 5
 - Media adapter slot 4
 - RJ-45 connectors 4

H–L

- Humidity
 - operating and storage 31
- IEEE 100BASE-T 802.3u standard 23, 31
- Input power specification 31
- Input voltage (rms) specification 31
- Installing
 - cascade cables 11
 - hubs
 - in a rack 10
 - on a table or shelf 10
 - mounting brackets 10
 - NMM 13
 - uplink modules 12
- Interface options 32
- LEDs
 - 1 Media Adapter 6, 17
 - checking 16
 - Col 5
 - Data % (utilization) 6, 17
 - Enbl 6, 17
 - Expansion Slot Stat 6
 - Management Mstr 17
 - Management Stat 6, 17

- matrix 4
- Mstr 6
- Port Status 6, 17
- Pwr 5, 16
- Stat 5, 16
- Length
 - cables 24
 - collision domain 24

M–O

- Management module
 - description 30
 - installing 13
 - numbering convention 11
- Management Mstr LED
 - operating conditions 6
 - verifying installation 17
- Management Stat LED
 - operating conditions 6
 - verifying installation 17
- Media Adapter LED
 - operating conditions 6
 - verifying installation 17
- Media adapter slot 8
- Media specification coding schemes 24
- Mounting brackets
 - installing 10
 - removing 12
- NMM (Network Management Module)
 - description 30
 - installing 13
 - unit numbering convention 11
- Non-100BASE-T4 devices
 - connecting to 100BASE-FX 21
 - connecting to 100BASE-TX 20
 - connecting to 10BASE-T 21
- Numbering convention 18
- Operating conditions 9

- Optional equipment
 - cascade cables 30
 - NMM 30
 - uplink modules 29

P–S

- Panel
 - front 4
 - rear 7
- Partitioned ports 18
- Physical layer media specifications 23
- Physical specifications
 - dimensions 31
 - weight 31
- Port Status LEDs
 - operating conditions 6
 - verifying installation 17
- Power cord restrictions 10
- Power receptacle 7
- Pwr LED
 - operating conditions 5
 - verifying installation 16
- Quick start 1
- Rear panel features
 - AC power receptacle 7
 - Cascade Down connector 7
 - Cascade Up connector 7
- Removing
 - hubs
 - from a rack 12
 - from a shelf or table 12
 - mounting brackets 12
- Repeater rules 25
- Requirements
 - cable length (maximum) 24
 - humidity 9
 - rack installation 9
 - table and shelf installation 9
 - temperature 9
 - ventilation 9

Restrictions, power cords	10	Weight	31
RJ-45 connectors		Wiring hardware	9
connecting cable	15	Wiring standard	
hub front panel	4	EIA/TIA 568	23
interface options	32	Workgroups, 100 Mbps	19
media specification parameters	24		
pin pairings	4		
pinouts	4		
Rules			
cable length	24		
distance limitations	24		
repeater	25		
Safety agency approvals	32		
SC connectors	15, 24, 32		
Service access	9		
SNMP	30		
Specifications			
physical layer media	23		
Stacking			
100BASE-T4 and 100BASE-TX hubs	15		
100BASE-T4 hubs	11		
100BASE-TX and 100BASE-T4 hubs	20		
numbering convention	18		
Standards			
IEEE 100BASE-T 802.3u	23		
Stat LED			
operating conditions	5		
verifying installation	16		

T–W

Technical specifications	31
Temperature	
requirements	31
Thermal rating	31
Topology rules	
Fast Ethernet	23
Uplink modules	
100BASE-FX	8
100BASE-TX	8
UTP requirements	24
Volt amperes rating	31

Intel Automated Customer Support

You can reach Intel's automated support services 24 hours a day, every day at no charge. The services contain the most up-to-date information about Intel products. You can access installation instructions, troubleshooting information, and general product information.

	World Wide Web & Internet FTP	Intel BBS
	Access Intel's World Wide Web home page or download information using anonymous FTP.	Use Intel's Bulletin Board. Dial in by modem at 8-N-1, and up to 14.4 Kbps.
Troubleshooting	✓	
Software updates	✓	✓
Installation notes	✓	
Product information	✓	
How to access:	WWW <i>News:</i> news://cs.intel.com <i>Customer Support:</i> http://www-cs.intel.com FTP <i>Host:</i> ftp.intel.com <i>Directory:</i> /support	US and Canada 1-503-264-7999 Europe +44-1793-432955 Worldwide +1-503-264-7999

Intel Customer Support Technicians

Free support for 90 days: You can speak with our technical support professionals free of charge for 90 days after your initial call.

Other support services: You can purchase a range of support services, including 24 hour support, per incident support, on-site service, and software and hardware maintenance agreements. For details about the Intel Support Service options, download document 8549 from one of the automated services.

Worldwide access: Intel has technical support centers worldwide. Many of the centers are staffed by technicians who speak the local languages. For a list of all Intel support centers, the telephone numbers, and the times they are open, download document 9089 from one of the automated services.

If you don't have access to automated services, contact your local dealer or distributor.
 Or call +1-503-264-7000 from 07:00 to 17:00 Monday through Friday., U.S. Pacific Time