



---

# **All-in-Wonder®**

# **X800 PCI Express®**

**Installation and Setup**  
**User's Guide**

P/N 137-70971-10

Copyright © 2005, ATI Technologies Inc. All rights reserved.

ATI, the ATI logo, and ATI product and product-feature names are trademarks and/or registered trademarks of ATI Technologies Inc. All other company and/or product names are trademarks and/or registered trademarks of their respective owners. Features, performance and specifications are subject to change without notice. Product may not be exactly as shown in diagrams.

Reproduction of this manual, or parts thereof, in any form, without the express written permission of ATI Technologies Inc. is strictly prohibited.

### **Disclaimer**

While every precaution has been taken in the preparation of this document, ATI Technologies Inc. assumes no liability with respect to the operation or use of ATI hardware, software or other products and documentation described herein, for any act or omission of ATI concerning such products or this documentation, for any interruption of service, loss or interruption of business, loss of anticipatory profits, or for punitive, incidental or consequential damages in connection with the furnishing, performance, or use of the ATI hardware, software, or other products and documentation provided herein.

ATI Technologies Inc. reserves the right to make changes without further notice to a product or system described herein to improve reliability, function or design. With respect to ATI products which this document relates, ATI disclaims all express or implied warranties regarding such products, including but not limited to, the implied warranties of merchantability, fitness for a particular purpose, and non-infringement.

### **Product Notices**

Dolby® Laboratories, Inc.

Manufactured under license from Dolby® Laboratories. Dolby and the double-D symbol are trademarks of Dolby Laboratories. Confidential Unpublished Works.  
© 1992-1997 Dolby Laboratories, Inc. All rights reserved.

### **Macrovision**

Apparatus Claims of U.S. Patent Nos. 4,631,603, 4,577,216, 4,819,098, and 4,907,093 licensed for limited viewing uses only.

This product incorporates copyright protection technology that is protected by method claims of certain U.S. patents and other intellectual property rights owned by Macrovision Corporation and other rights owners. Use of this copyright protection technology must be authorized by Macrovision Corporation, and is intended for home and other limited viewing uses only unless otherwise authorized by Macrovision Corporation. Reverse engineering or disassembly is prohibited.

### **Documentation Updates**

ATI is constantly improving its product and associated documentation. To maximize the value of your ATI product, you should ensure that you have the latest documentation. ATI's documentation contains helpful installation/configuration tips and other valuable feature information.



## IMPORTANT SAFETY INSTRUCTIONS

- **Read Instructions** - All the safety and operating instructions should be read before the product is operated.
- **Retain Instructions** - The safety and operating instructions should be retained for future reference.
- **Heed Warnings** - All warnings on the product and the operating instructions should be adhered to.
- **Compatibility** - This option card is for use only with IBM AT or compatible UL Listed personal computers that have Installation Instructions detailing user installation of card cage accessories.
- **Grounding** - For continued protection against risk of electric shock and fire, this accessory should be installed only in products equipped with a three-wire grounding plug, a plug having a third (grounding) pin. This plug will only fit into a grounding-type power outlet. This is a safety feature. If you are unable to insert the plug into the outlet, contact your electrician to replace the obsolete outlet. Do not defeat the safety purpose of the grounding-type plug.
- **Secure Attachment** - All card securement pins shall be completely tightened as to provide continuous bonding between the option card and the PC chassis.
- **Outdoor Antenna Grounding** - Since an outdoor antenna or cable system is connected to the product, be sure that the antenna or cable system is grounded so as to provide some protection against voltage surges and built-up static charges. Article 810 of the National Electrical Code, ANSI/NFPA 70, provides information with regard to proper grounding of the mast and supporting structure, grounding of the lead-in wire to the antenna discharge unit, size of grounding conductors, location of antenna-discharge unit, connection of grounding electrodes, and requirements for the grounding electrode.
- **Lightning** - For added protection for this product during a lightning storm, or when it is left unattended and unused for long periods of time, unplug it from the wall outlet, and disconnect the antenna or cable system. This will prevent damage to the product due to lightning and power-line surges.
- **Power Lines** - An outside antenna system should not be located in the vicinity of overhead power lines or other light or power circuits, or where it can fall into such power lines or circuits.
- **Antenna Installation** - When installing an outside antenna system, extreme care should be taken to keep from touching such power lines or circuits, as contact with them may be fatal.
- **Note to CATV System Installer** - This reminder is provided to call the CATV systems installer's attention to Section 820-40 of the NEC, which provides guidelines for proper grounding and, in particular, specifies that the cable ground shall be connected to the grounding system of the building, as close to the point of cable entry as practical.



# Contents

<b>Getting Started</b> .....	<b>1</b>
System Requirements	2
Before You Begin	2
<i>Record Your Serial and Part Numbers</i>	2
<i>Update Your PCI Express® Chipset Drivers</i>	3
<i>Uninstall Previous Graphics Card Drivers</i>	4
<b>Installing Hardware</b> .....	<b>5</b>
Quick Installation	5
<i>Installation Steps</i>	5
Detailed Installation	5
<i>Installing the Card</i>	6
<i>Connecting Display Devices</i>	7
<i>Turning on the System</i>	8
Input and Output Adapters	9
<i>Watching or Recording Movies on a PC         and Recording from a VCR or Camcorder</i>	9
<i>Watching PC Output on a TV and Recording on a VCR</i>	10
<i>Watching your PC Output on High-definition TV</i>	11
<i>Compatibility with Earlier All-in-Wonder® Products</i>	12
<i>Using the SCART Connector</i>	13
<b>Installing Software</b> .....	<b>15</b>
Installing Drivers and Software in Windows®	15
<i>Software Installation Prerequisites</i>	15
HydraVision™ Multi-monitor Management	16
Monitor Configuration	17
Reinstalling Drivers	17
Starting the ATI Multimedia Center	18
<b>Catalyst™ Control Center</b> .....	<b>19</b>
Launching Catalyst™ Control Center	19
<i>Launching Catalyst™ Control Center Using the Start Menu</i>	20

<i>Other Quick Launch Access Points</i>	20
Displays Manager	21
Video	23
Display Options	23
Color	23
Monitor Properties	24
Component Video Properties	24
Digital Panel Properties	24
Hotkeys Manager	25
ATI Overdrive 3	25
Profiles Manager	26
Preferences	26
Help	27
<b>Using TV Display and Capture Features . . . . .</b>	<b>29</b>
Using TV Out	29
<i>Viewing Your PC's Display on a TV</i>	29
<i>Connecting to a TV</i>	29
<i>Starting Windows® with TV Display Enabled</i>	29
<i>Using and Adjusting TV Display Features</i>	30
<i>TV Display Hardware Restrictions</i>	30
<i>Using a Monitor vs. Using TV Display</i>	30
<i>Adjusting Monitor Display</i>	31
<i>Viewing Text on a TV</i>	31
<i>Reducing Edge Distortion</i>	31
<i>Using a TV as the Only Display</i>	31
<i>Using Games and Applications</i>	31
<b>Using Multiple Displays . . . . .</b>	<b>33</b>
<i>Connecting Your Monitors</i>	33
Display Configurations	35
MulTVView™	37
<i>MulTVView™ Audio Requirements</i>	38
<i>EazyLook™</i>	38
<b>Reference . . . . .</b>	<b>39</b>
Troubleshooting	39
Product Registration	41
Customer Care	42
Warranty Information	43
<i>Hardware Warranty Service Statement</i>	43
<i>Warranty Service</i>	43

---

<i>Limitations</i>	44
Getting Additional Accessories	44
Compliance Information	45
FCC Compliance Information	45
<i>Industry Canada Compliance Statement</i>	45
<i>CE Compliance Information</i>	46
<i>Informations de conformité de la CE</i>	46
<i>Electrical Safety</i>	46
<i>Waste Electrical and Electronic Equipment (WEEE) Directive Compliance</i>	46





## CHAPTER 1:

# Getting Started

Welcome to the convergence of your PC with TV and video. The All-in-Wonder® X800 PCI Express® Series of graphics cards add TV, Personal Video Recording, and powerful video acceleration to your PC. TV-on-Demand™ and several other software features are included to enhance your television experience.

When attached to a video camera, your All-in-Wonder® X800 PCI Express® Series can add time-lapse video recording to your PC for security applications. Your card's advanced video recording and editing features also give you video CD and DVD authoring capability.

You can use your All-in-Wonder® X800 PCI Express® Series card to connect your computer to a television. This feature is ideal for playing games, giving presentations, watching movies, and browsing the Internet.

The All-in-Wonder® X800 PCI Express® Series also turns your PC into an intelligent TV with the following features:

<b>TV-on-Demand™</b>	<b>ThruView™</b>
<b>MuTV™</b>	<b>TV Magazine™</b>
<b>EazyLook™</b>	<b>Zoom and Pan</b>
<b>Scheduled Viewing</b>	<b>Channel Scanning</b>
<b>Video Recording</b>	<b>Closed Captioning with HotWords™</b>
<b>Program Transcript Recording (North America only)</b>	<b>Interactive Program Guide (in selected countries)</b>
<b>Personal Video Recorder with Real-Time Video Compression</b>	<b>Remote Wonder™ USB RF Remote Control (optional)</b>
<b>AC-3 Digital Audio Playback supporting Dolby® 5.1 surround sound</b>	

# System Requirements

<b>Hardware</b>	<ul style="list-style-type: none"><li>• Intel® Pentium® 4, AMD Athlon®, or compatible.</li><li>• 128 MB of system memory; 256 MB or more for best performance</li><li>• Motherboard with free PCI Express® slot and correct PCI Express® chipset-driver</li><li>• CD-ROM drive (for installation software).</li><li>• 300 watt or greater power supply recommended (350 watt power supply may be required in some fully loaded PC systems)</li></ul>
<b>Operating System</b>	<ul style="list-style-type: none"><li>• Windows® XP Home or Professional (Service Pack 2)</li><li>• Windows® XP Media Center Edition 2005 (MCE)</li></ul>
<b>Monitor</b>	<ul style="list-style-type: none"><li>• High-resolution MultiSync or multi-frequency monitor or any other type of VGA monitor</li><li>• Digital flat-panel or digital CRT display</li></ul>

## Before You Begin

Before you begin installing your new All-in-Wonder® X800 PCI Express® Series graphics card, please do the following.

## Record Your Serial and Part Numbers

The serial number and 102 part number printed on the graphics card are required for registration. They are located on a sticker on the back of the card.



- 
- 1 Serial number (S/N)
-

---

② 102 part number (P/N)

---

Write these numbers down before installing your new ATI product.

## Update Your PCI Express® Chipset Drivers

Your All-in-Wonder® X800 PCI Express® card uses the PCI Express® bus, and it requires drivers that enable the PCI Express® functionality for your motherboard's chipset.

Ensure you have installed the latest PCI Express® chipset drivers before replacing your current graphics card.

### *Determining the motherboard chipset*

- 1 Open the Control Panel from the Start Menu and select **System**; in Windows® XP's Category View, System can be found under Performance and Maintenance.
- 2 In the System Properties dialog, select the **Hardware** tab.
- 3 Select **Device Manager**.
- 4 From the Device Manager tree view, expand the System Devices branch.
- 5 Scroll through the list of system devices until you find a listing for the PCI Express controller. Often you will see the name of a motherboard chipset in connection with these terms. The chipset manufacturer's name will appear as part of the device name.

Once you have determined the chipset manufacturer for your motherboard, obtain and then install the latest PCI Express® drivers from that manufacturer's Web site.



**WARNING** - Installing the wrong PCI Express® chipset drivers may prevent you from successfully launching Windows®. Make sure that the drivers you install are designed to function correctly with your motherboard. If you are uncertain, please consult with your motherboard manufacturer for advice.

For your convenience, here is a list of common chipset manufacturers:

---

VIA Technologies

[www.viaarena.com](http://www.viaarena.com)

---

Acer Laboratories (ALI)	<a href="http://www.ali.com.tw">www.ali.com.tw</a>
Silicon Integrated Systems (SIS)	<a href="http://www.sis.com">www.sis.com</a>
Advanced Micro Devices (AMD)	<a href="http://www.amd.com">www.amd.com</a>
Intel Technologies	<a href="http://support.intel.com">support.intel.com</a>
General Motherboard/chipset information	<a href="http://www.motherboards.org">www.motherboards.org</a>
ATI	<a href="http://www.ati.com">www.ati.com</a>

## Uninstall Previous Graphics Card Drivers

To ensure the successful installation of your new All-in-Wonder® X800 PCI Express® card, you must uninstall the drivers for the existing graphics card before removing it from your computer.

### *To uninstall previous drivers*

With your current graphics card still in your computer:

- 1 Close all applications that are currently running.
- 2 Navigate to the **Control Panel** and select **Add/Remove Programs**.
- 3 Select your current graphics card drivers and select **Add/Remove**. The wizard will help you remove your current display drivers.

**Note:** If the previously installed graphics card has any additional software installed, it should also be removed at this point.

- 4 Restart your system after the drivers have been removed.

## CHAPTER 2:

# Installing Hardware

This chapter will guide you through the physical installation of your All-in-Wonder® X800 PCI Express® card.

## Quick Installation

For experienced users and system administrators, follow these brief instructions for installing your All-in-Wonder® X800 PCI Express® card in the shortest possible time.

### Installation Steps

- 1 Uninstall the drivers and software for your old graphics card.



If you are using a motherboard containing an on-board graphics solution and do not intend to use it as part of a multiple monitor display, disable it.

- 2 Shut down and disconnect your computer system.
- 3 Remove any previously installed card.
- 4 Install your new All-in-Wonder® X800 PCI Express® card.
- 5 Reassemble and connect your computer system.
- 6 Install the All-in-Wonder® X800 PCI Express® drivers and configuration software from the ATI Installation CD-ROM by doing one of the following:
  - Run through the automatic **ATISSETUP** utility; or
  - **Start > Run > X:\ATISSETUP.EXE** (where **X** is the drive letter of your CD-ROM drive).

## Detailed Installation

The following instructions will take you step by step through the installation of your new All-in-Wonder® X800 PCI Express®.

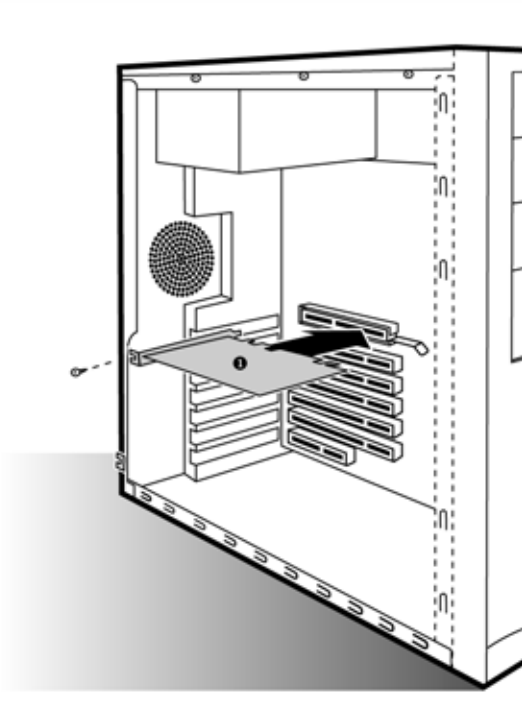

All-in-Wonder® X800 PCI Express® Graphics Card

## Installing the Card

- 1 Turn off the computer, monitor, and other peripheral devices.
- 2 Unplug the computer's power cord and disconnect all cables from the back of your computer.



To avoid possible damage to the motherboard, wait approximately 20 seconds after unplugging the power cord.

- 3 Remove the computer cover. If necessary, consult your computer's manual for help in removing the cover.
- 4 Discharge your body's static electricity by touching the power supply or the metal surface of the computer chassis.

- 5 Unscrew or unfasten and remove any existing graphics card from your computer.



If your computer has an on-board graphics capability, you may need to disable it on the motherboard. For more information, see your computer documentation.

- 6 Locate the appropriate slot and, if necessary, remove the metal back-plate cover.
- 7 Align your ATI graphics card with the slot and press it in firmly until the card is fully seated.
- 8 Screw in or fasten the graphics card securely. Make sure the cables are not interfering with anything inside the computer (for example, a cooling fan).
- 9 Replace the computer cover.
- 10 Reconnect any cables you have disconnected and plug in the computer's power cord.
- 11 Before turning your computer on again, connect the appropriate display devices.

## Connecting Display Devices

The following connections are available:

- VGA — for standard VGA monitors.
- DVI-I — for digital flat-panel displays.

You can connect an analog CRT display using an optional DVI-I-to-VGA adapter, as shown.

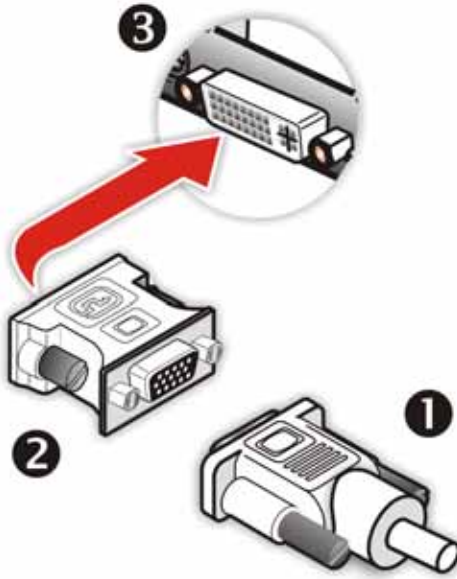

- 
- ① Male VGA connector leading to analog monitor
  - ② DVI to VGA adapter
  - ③ Female DVI connection
- 

## Turning on the System

- ⓘ **WARNING** - Turn on your monitor before you turn on your computer. Failure to do so could damage your monitor.

If you have properly installed your graphics card, operating system messages will appear once the boot procedure is finished.

Your monitor will be running in a basic video mode. Higher refresh rates are not available at this stage of the installation. Once you have installed the All-in-Wonder® X800 PCI Express® drivers and software, you can use the Display Properties control panel to adjust the video settings and configure multiple monitors.



## Input and Output Adapters

Your All-in-Wonder® X800 PCI Express® uses input and output adapters that let you connect audio and video devices to the card (for example, TV, VCR, or camcorder).

**i** Your All-in-Wonder® X800 PCI Express® card uses a digital audio path. The card's audio output does not require a separate connection to your sound card to hear the audio accompanying your video output.

This section outlines the configuration to use for a variety of situations.

### Watching or Recording Movies on a PC and Recording from a VCR or Camcorder

Use the ATI input adapter to connect a VCR or camcorder to your All-in-Wonder® X800 PCI Express® card, as shown.

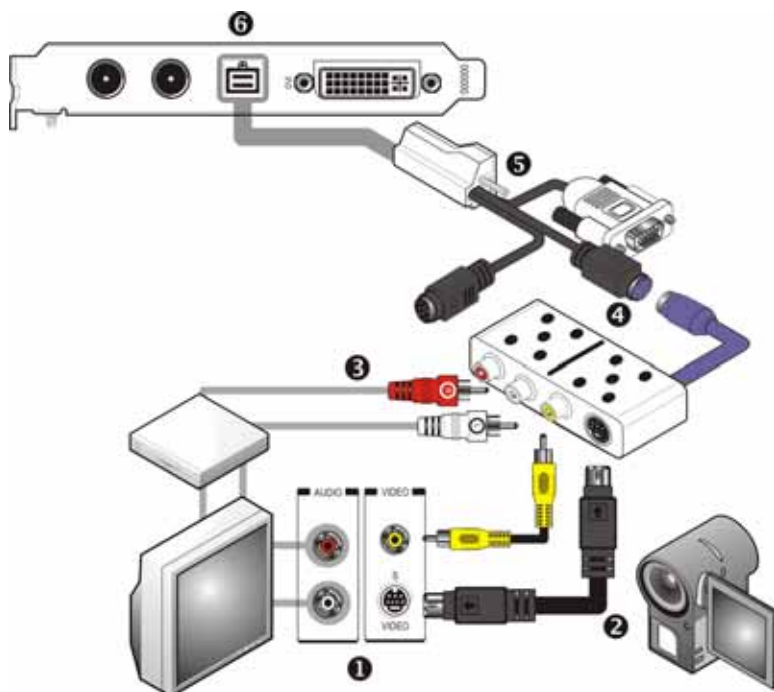

- 
- 1** Typical VCR or camcorder audio and video output connectors. Use composite video out **or** S-Video out.
-

---

2	Cable with S-Video plug at each end.
3	Cables with RCA plug at each end, available separately from a consumer electronics dealer.
4	ATI Input Adapter.
5	Input / Output connector.
6	All-in-Wonder® X800 PCI Express® card.

---

## Watching PC Output on a TV and Recording on a VCR

Use the ATI output adapter to connect a TV, camcorder, or VCR to your All-in-Wonder® X800 PCI Express® card, as shown.

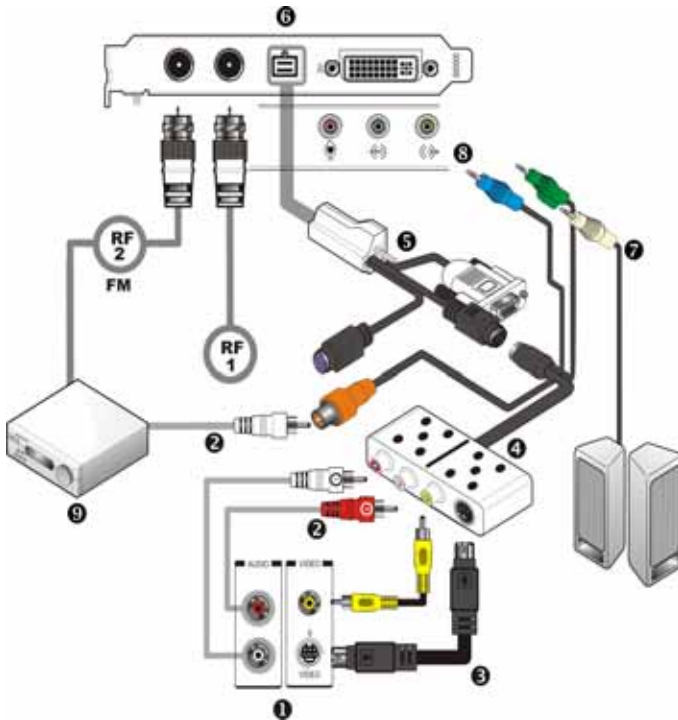

---

**RF1** Cable TV connection - Analog (and DVB-T where available).

---

**RF2** Cable FM Radio connection.

---

- 1 Typical VCR or camcorder audio and video input connectors. Use composite video in **or** S-Video in; S-Video will provide better results. To use your TV as a display, you must enable TV Out .
- 2 Cables with RCA plug at each end, available separately from a consumer electronics dealer.
- 3 Cable with S-Video plug at each end.
- 4 ATI Output Adapter. You can snap the adapters together for convenient placement and use.
- 5 Input / Output connector
- 6 All-in-Wonder® X800 PCI Express® card.
- 7 PC speaker connection (optional).
- 8 Line-In to sound card
- 9 Dolby® Digital AC-3 Amplifier.

## Watching your PC Output on High-definition TV

Use the ATI output adapter to connect a high definition TV (North America only) to your All-in-Wonder® X800 PCI Express® card, as shown.

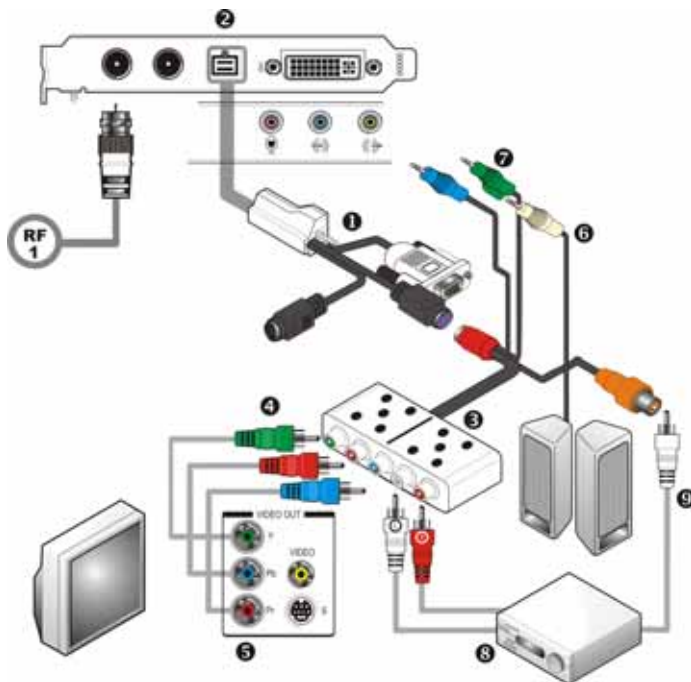

1	Input / Output Adapter.
2	All-in-Wonder® X800 PCI Express® card.
3	ATI HD Output Adapter.
4	Cables with RCA plug at each end, available separately from a consumer electronics dealer.
5	Typical HDTV video inputs. <b>Note:</b> Input and output cable lengths should not exceed 50 feet (15m). Y = Green Pb = Blue Pr = Red
6	Cable with mini-stereo plug at each end, available separately from a consumer electronics dealer, for connecting PC speakers (optional).
7	LINE IN to sound card
8	Dolby® Digital AC-3 Amplifier.
9	Cable with RCA plug at each end, available separately from a consumer electronics dealer.

## Compatibility with Earlier All-in-Wonder® Products

If you have input and output devices connected to an earlier All-in-Wonder® product, the input/output adapter included with your All-in-Wonder® X800 PCI Express® card lets you easily reattach those devices.

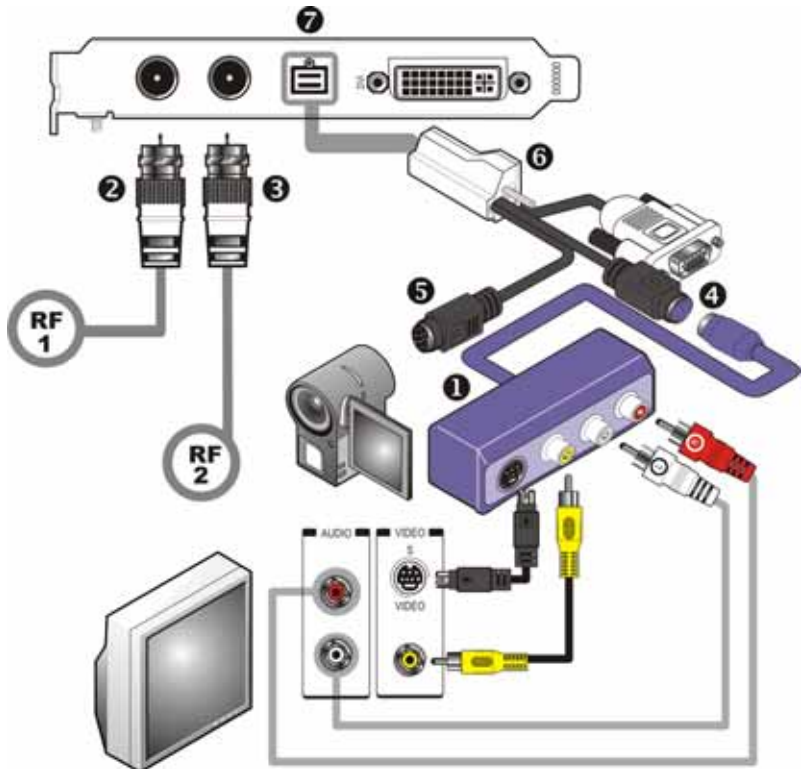

- 
- 1 ATI input adapter used with earlier All-in-Wonder® products.
- 
- 2 **RF1** F-connector for cable TV input.
- 
- 3 **RF2** F-connector for cable FM radio input.
- 
- 4 ATI input connector used with earlier All-in-Wonder® products.
- 
- 5 S-Video connector
- 
- 6 Input / Output connector.
- 
- 7 All-in-Wonder® X800 PCI Express® card.
- 

## Using the SCART Connector

SCART is an acronym for “Syndicat des Constructeurs d’Appareils Radiorécepteurs et Téléviseurs”. SCART is an analog 21-pin connector used mainly in Europe for transferring audio and video signals between

VCRs, DVD players, personal computers, and set-top boxes. It is sometimes referred to as Péritel or the Euroconnector.

Your All-in-Wonder® X800 PCI Express® comes with a SCART adaptor for connecting to compatible equipment as shown.

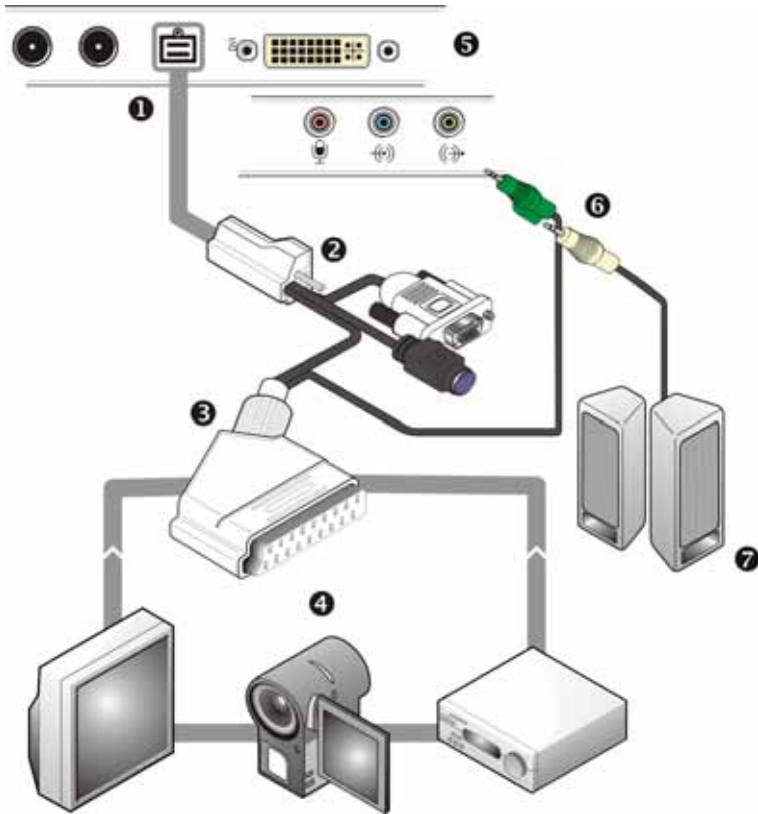

- |   |  |
|---|--|
| 1 | All-in-Wonder® X800 PCI Express® card.   |
| 2 | Input / Output connector.  |
| 3 | SCART Adapter  |
| 4 | SCART compatible TV, VCR, Camcorder  |
| 5 | PC sound card  |
| 6 | Cable with mini-stereo plug at each end, available separately from a consumer electronics dealer, for connecting PC speakers (optional). |
| 7 | PC Speakers  |

## CHAPTER 3:

# Installing Software

This chapter will guide you through the installation of the drivers and software associated with your All-in-Wonder® X800 PCI Express® graphics card.

## Installing Drivers and Software in Windows®

You will need to install the All-in-Wonder® X800 PCI Express® drivers and software in the following cases:

- After you have installed the card in your system.
- After you have reinstalled or upgraded your operating system.

This procedure applies to Windows® XP.

### Software Installation Prerequisites

To install or remove the drivers, you must have administrator rights or be logged on as a user with administrator rights.

Your operating system must be installed and running before you can install the All-in-Wonder® X800 PCI Express® drivers. You must also have Service Pack 1 (or higher) for Windows® XP.

Make sure your monitor cable is properly attached before you begin.

**Note:** The installation dialog will display in English if your operating system's language is not supported.

### *To install ATI drivers and software*

- 1 Start your system. When the **Found New Hardware Wizard** comes up, click **Cancel**. When the **System Settings Change** window asks you to restart your computer, click **No**.

- 2 Run the **ATIS SETUP** utility. The **ATIS SETUP** utility will start automatically if you insert the ATI Installation CD-ROM into your CD-ROM drive after the operating system has started. If your CD-ROM auto-run is not enabled or the **ATIS SETUP** utility does not start automatically:
    - a) Click the **Start** button in the task bar.
    - b) Click **Run**.
    - c) Select **ATIS SETUP.EXE** from the root directory of the ATI Installation CD-ROM.
    - d) Click **OK**.
  - 3 Click **Install** under Software Install.
  - 4 Click **Next**.
  - 5 Click **Yes** to the license agreement. ATI Easy Install will start the Installation Wizard.
  - 6 Follow the wizard's on-screen instructions to complete the installation.
-  The Express installation option is recommended. The HydraVision™ multi-monitor and desktop management software will automatically be installed, along with the ATI driver, by selecting this option. Not all software components are installed using the Express installation. Custom installation allows you to select individual software components for installation.
- 7 When the Setup complete message appears, select **Yes, I want to restart my computer now** and click **Finish**.
  - 8 After the system reboots, the **Found New Hardware** message may display the **Digital Signature Not Found** message. Click **Yes** or **Continue** to complete the driver installation.

## HydraVision™ Multi-monitor Management

The HydraVision™ multi-monitor and desktop management software will install automatically with the Express driver installation of the ATIS SETUP utility.



If you do not want to install HydraVision™, select the Custom driver installation and clear the HydraVision™ check box.



For more information consult the HydraVision™ user's guide included on the ATI Installation CD-ROM.

## Monitor Configuration

Once the drivers and software have been installed, you can configure your monitor..



**Warning** - Choosing a refresh rate unsupported by your monitor may damage your monitor. Consult your monitor's documentation if necessary.

### *To configure your primary display*

- 1 Navigate to the **Control Panel** and choose **Display**, or right-click on the desktop and choose **Properties**.
- 2 Choose the **Settings** tab and select the screen resolution and color depth that best suit your requirements and your monitor's performance.
- 3 Click **Advanced** and select the **Monitor** tab.
- 4 Choose a refresh rate from the drop-down list.
- 5 Click **OK** to return to the desktop.

## Reinstalling Drivers

You can install new drivers or reinstall existing drivers if there was a Windows® conflict.

Reinstall the drivers at any time using the **ATISSETUP** utility located on the ATI Installation CD-ROM. The **ATISSETUP** utility will start automatically if you insert the ATI Installation CD-ROM into your optical drive after the operating system has started.

### *To manually reinstall drivers*

If your CD-ROM auto-run is not enabled and the **ATISSETUP** utility does not start automatically, follow these steps.

- 1 In the Windows® task bar, click **Start**.
- 2 From the **Start** menu, select **Run**.

- 3 Browse to **ATISSETUP.EXE** on the root directory of the ATI Installation CD-ROM.
- 4 Click **OK**.

## Starting the ATI Multimedia Center

The LaunchPad provides a convenient way to start all your Multimedia Center features — just click the one you want. LaunchPad opens automatically when you start your computer.



To disable this feature, right-click LaunchPad, and clear the **Load on Startup** option in the drop-down menu.



---

ATI Multimedia Center™ LaunchPad

---

### *Starting ATI Multimedia Center™ from Windows® taskbar*

- 1 In the Windows® taskbar, click **Start**, and then point at **Programs**.
- 2 Point to **ATI Multimedia Center™**, and then select the feature you want to run.

For information on the ATI Multimedia Center™, see the User's Guide and the online help.



The first time you launch TV, you must complete the Initialization Wizard, which guides you through setting up TV. After that, the Wizard will not run unless you want to rerun it.

## CHAPTER 4:

# Catalyst™ Control Center

The Catalyst™ Control Center is a graphical user application providing access to the display features contained within the installed ATI hardware and software. Use the Catalyst™ Control Center to fine-tune your graphics settings, enable or disable connected display devices, and change the orientation of your desktop. Many of the features show you a preview of the changes before they are applied.

The Catalyst™ Control Center offers you two views of the software:

- Standard View is a simplified view that includes wizards to get the inexperienced user up and running.
- Advance View allows the advanced user to access and configure the complete feature set of the software.

The Catalyst™ Control Center can be customized for easy access to the features you use most.

Use the Catalyst™ Control Center to access a comprehensive online help system, or connect to the ATI Web site.

## Launching Catalyst™ Control Center

Catalyst™ Control Center can be launched from one of the following access points:

- Windows® Start Menu
- Windows® System Tray
- Predefined Hotkeys
- Desktop Shortcuts
- Via an ATI Multimedia Center™ Application.

## Launching Catalyst™ Control Center Using the Start Menu

From the windows task bar, click the **Start** button:

- For Windows® XP, point to **All Programs > ATI Catalyst™ Control Center**.

## Other Quick Launch Access Points

### ***Launching Catalyst™ Control Center from ATI Multimedia Center™***

You can also access the Catalyst™ Control Center while an ATI Multimedia Center™ application, like TV Player, is running. Simply click the Catalyst™ Control Center icon in the multi-media application's control panel, if available.

### ***Launching Catalyst™ Control Center Using Hot Keys***

You can press a predefined key (like **F7**) or combination of keys (like **Ctrl+A**). You can define your hot key by using the Hotkey Manager.

### ***Launching Catalyst™ Control Center Using the Desktop Shortcut***

When you first installed Catalyst™ Control Center the setup wizard provided you with the option of placing a shortcut on the desktop. If you selected this option, simply double-click the Catalyst™ Control Center desktop shortcut.

### ***Launching Catalyst™ Control Center Using the System Tray***

Right-click the **ATI** icon in the Windows® System Tray and select Catalyst™ Control Center from the popup menu.



---

Catalyst™ Control Center Dialog

---

## Displays Manager

The Displays Manager aspect is the central location for configuring your display devices and arranging your desktop. Use the Displays Manager aspect to quickly change your display setup, arrange your desktop in a multi-monitor environment, and enable TV Out.

Those new to the Catalyst™ Control Center may use the Standard View wizard to help you configure your display preferences. Experienced users who prefer to manually configure their desktop setting should use the Advanced View.



Catalyst™ Control Center: Standard View



Catalyst™ Control Center: Advanced View

## Video

Use the Video aspect to use preconfigured profiles that best match your viewing environment. Switch to the Advanced view to manually adjust video overlay and choose a preferred viewing mode, such as Widescreen or Fullscreen modes.

### *To access the Video aspect*

- Select **Video** in either Standard or Advanced View.

## Display Options

The Display Options aspect gives you additional control to optimize performance of OpenGL® and Direct 3D® applications.

Use 3D Refresh Rate Override to set a refresh rate of your choice when a full-screen application or game has a default refresh rate that is lower than optimal.

Choose one of the Display Detection Options to prevent screen flicker when detecting a display.

If you are using an older TV or one that has non-standard inputs that may not be automatically detected, use **Force TV Detection**. When a TV is detected using this method, it appears in the Displays Manager aspect and can be configured as required. However, some features that rely on automatic detection, such as extended desktop, will not be supported.

### *To access the Display Options aspect*

- Select **Display Options** in Advanced View.

## Color

Use the Color aspect to adjust the color settings for your desktop and full-screen games. The Preview effects area shows your changes to gamma, brightness, and contrast in real time.

### *To access the Color aspect*

- Select **Color** in Advanced View.

## Monitor Properties

Use the Monitor Properties aspect to configure your Display Data Channel (DDC) monitor's attributes, to display information about the connected monitor, and adjust the output display's position and size.

**Note:** Catalyst™ Control Center loads aspects dynamically based on what device is attached to the graphics card. If you have a display device other than a standard monitor or flat panel display (such as a HDTV screen) *Digital Panel Properties* will appear in the Graphics Settings listing instead of *Monitor Properties*.

### **To access the Monitor Properties aspect**

- Select **Monitor Properties** in Advanced View.

## Component Video Properties

The Component Video Properties aspect of the Catalyst™ Control Center adds further support when using the ATI HDTV Component Video Adapter.

Component Video Properties is made up of:

- Formats
- Adjustments
- Advanced

### **To access the Component Video Properties aspect**

- Select **Component Video Properties** in Advanced View.

## Digital Panel Properties

Use the Digital Panel Properties aspect to configure the DVI settings and Image Scaling to improve image quality without impacting performance. Use HDTV Support to add EDID information (containing information about the capabilities of the display) about your connected HDTV display to the **Force** button in Displays Manager.



**Note:** Catalyst™ Control Center loads aspects dynamically based on what device is attached to the graphics card. If you have standard display device such as a CRT monitor or flat panel display *Monitor Properties* will appear instead of *Digital Panel Properties*. The latter is designed for use with such devices as HDTV displays.

## Hotkeys Manager

The Hotkeys Manager allows you to create shortcut key combinations to quickly perform tasks such as changing a graphics setting or opening an application. A hot key is a combination of one or more modifier keys, such as Ctrl, Alt, or Shift, and any letter from the alphabet.

### **To access Hotkeys Manager**

- Click **Hotkeys** in the Catalyst™ Control Center.

## ATI Overdrive 3

Use the ATI Overdrive 3 aspect to maximize the performance of the graphics processing unit (GPU) on your graphics card. An on-chip thermal sensor constantly monitors the temperature of the GPU allowing the maximum clock speed to be maintained while avoiding overheating. If the GPU gets too hot, the ATI Overdrive 3 aspect will automatically decrease the clock speed until a safe temperature is reached. The ATI Overdrive 3 aspect will never reduce the graphics processor speed below the default clock speed.

Use the Automated clock configuration utility to obtain the ATI recommended the ATI Overdrive 3 aspect speeds for the graphics processor clock and video memory clock. Alternatively, manually set these speeds to meet your specific requirements. Finally, the ATI Overdrive 3 aspect can be configured to run when the computer is booted or only when running 3D applications.

- If your computer cannot restart after setting a higher clock speed, press and hold the **SHIFT** key during system start-up until you hear three beeps. Once your computer has full booted, disable **Enable new clock settings at logon**.

### **To access the ATI Overdrive 3 aspect**

- Select **ATI Overdrive 3** in the Catalyst™ Control Center advanced view.

## **Profiles Manager**

Use profiles to create customized environments for your desktop, video, and 3D applications. Define and save into a profile your own personal video settings that can be quickly activated manually, through a hot key, or by file association.

**Note:** A profile applies to a specific graphics card. If there is more than one graphics card installed in your computer, you need to select the appropriate card before creating, loading, or activating a profile.

### **To access the Profiles Manager**

- Click the Profiles button in the Catalyst™ Control Center.

## **Preferences**

Use the Preferences page to restore factory defaults, change skins, or enable/disable the System Tray icon.

The Catalyst™ Control Center Preferences page contains the following options:

- Hide Tooltips
- Always on Top
- Enable System Tray menu
- Restore factory defaults
- Show Toolbar Text
- Select a Language
- Select a Skin

### **To access Preferences**

- Click **Preferences** in the Catalyst™ Control Center.

## Help

Use the Catalyst™ Control Center Help feature to access the comprehensive online help system, generate a Problem Report, and get the installed Catalyst™ Control Center version information.

### ***To access Help***

- Click the **Help** button in the Catalyst™ Control Center Dashboard.
- or
- Press the F1 key at any time to get specific help on the feature or aspect you are using.



## CHAPTER 5:

# Using TV Display and Capture Features

## Using TV Out

Your All-in-Wonder® X800 PCI Express® has TV Out capability. It also supports YPbPr component video output. For European customers, SCART-out is supported and included on the Input/Output connector.

## Viewing Your PC's Display on a TV

You can attach your graphics card to a TV and monitor at the same time. You can also connect it to your VCR and record your monitor's display.



### IMPORTANT INFORMATION for European Customers

Some PC monitors in Europe **cannot** be used simultaneously with TV display. When you enable TV display in Europe, the refresh rate for the monitor and TV is set to 50 Hz. Some monitors may not support this refresh rate **and could be damaged**.

- Please check the documentation supplied with your monitor to see if your monitor supports a refresh rate of 50 Hz.
- If your monitor does not support 50 Hz (or if you are not sure), turn off your monitor before turning on your PC when using your TV as a display.

TV display is ideal for giving presentations and watching movies, or playing games on a screen larger than a typical monitor. The following tips will help you get the most out of your TV Out feature.

## Connecting to a TV



To connect your All-in-Wonder® X800 PCI Express® card to a TV, use an S-Video cable.

## Starting Windows® with TV Display Enabled

The TV screen may become scrambled during the initial Windows® logo display. This distortion is only a temporary effect, and your screen will be restored within a few seconds.

During start up, your All-in-Wonder® X800 PCI Express® will go through a sequence of mode settings, during which your TV display will remain blank. This process takes only a few seconds and programs the TV display.

### **To enable or disable the TV display**

- 1 Access the Windows® **Control Panel**. Double-click **Display**.
- 2 Click the **Settings** tab and then the **Advanced** button.
- 3 Click the **ATI Displays** tab. Click the **TV** button.
- 4 Click the enable button  or disable button  accordingly.
- 5 Click **OK** or **Apply** to save the changes.

## **Using and Adjusting TV Display Features**

For information about how to adjust TV display features, right-click the **ATI taskbar icon**, point to **Help**, then point to **ATI Television Display**.

### **TV Display Hardware Restrictions**

A TV cannot be left connected to the graphics card if two analog monitors are connected to your All-in-Wonder® X800 PCI Express® card, even if the TV is off and not enabled in the software.

Similarly, an analog monitor connected to the DVI-I connector should not be left connected to your All-in-Wonder® X800 PCI Express® card when TV Out is enabled. In both cases, your All-in-Wonder® X800 PCI Express® will become overloaded, resulting in a dim image on all devices.

### **Using a Monitor vs. Using TV Display**

Using your TV for your computer's display can be useful, however, the display on your monitor may change or look squashed. This distortion occurs because the display adjusts to fit the dimensions of your TV. To correct the monitor's display, use the monitor's control buttons to adjust its display size and position.

Some single-frequency monitors may not work with TV display enabled. If you experience problems when TV display is enabled, disable TV display to restore your monitor's display.

## Adjusting Monitor Display

The size of the display on your monitor may become smaller and not perfectly centered when you have TV display enabled. These effects are caused by the changes your All-in-Wonder® X800 PCI Express® makes in order to render your desktop display on a TV screen.

Use the controls available on the **Adjustments** tab on the **Monitor Properties** page (accessible by clicking on the **Monitor** button on the ATI Displays tab) to adjust the display on your monitor only. Click the **TV** button to adjust the TV display only.

## Viewing Text on a TV

A TV is designed primarily to show moving images. The large dot pitch of a TV will yield poor quality static images. The small text sizes commonly used for PC desktops can appear blurred or unclear on a TV. You can compensate for this degradation by using larger fonts.

## Reducing Edge Distortion

When using a TV for your computer's display, you may see some edge distortion on the left and right side of your TV screen. This effect depends on your TV and the computer application you are running.

You can reduce edge distortion by increasing the TV display's horizontal size or contrast.

## Using a TV as the Only Display

If you plan to move your computer to a place where you are using TV display only, make sure that you have the TV display feature enabled prior to removing the monitor.

The maximum display resolution for TV is 1024 x 768. Choosing a resolution higher than this will cause the TV display to disappear if it is the only display device.

## Using Games and Applications

Some older games and applications may program your All-in-Wonder® X800 PCI Express® directly to run under a specific display mode. This may cause your TV display to turn off automatically or become scrambled (the PC monitor will not be affected). Your TV display will be restored once you exit the game or if you restart your computer.





## CHAPTER 6:

# Using Multiple Displays

This chapter describes how to attach multiple monitors to your All-in-Wonder® X800 PCI Express® card, as well as the allowable multi-display configurations.

### Connecting Your Monitors

Your All-in-Wonder® X800 PCI Express® provides hardware support for one DVI-I monitor or two VGA monitors using the optional DVI-I-to-VGA adapter. A TV can also be used to expand your desktop by using the S-Video out.



If you use multiple monitors, the All-in-Wonder® X800 PCI Express® card must be the primary graphics card. Normally, the system BIOS determines which graphics card will be the primary.

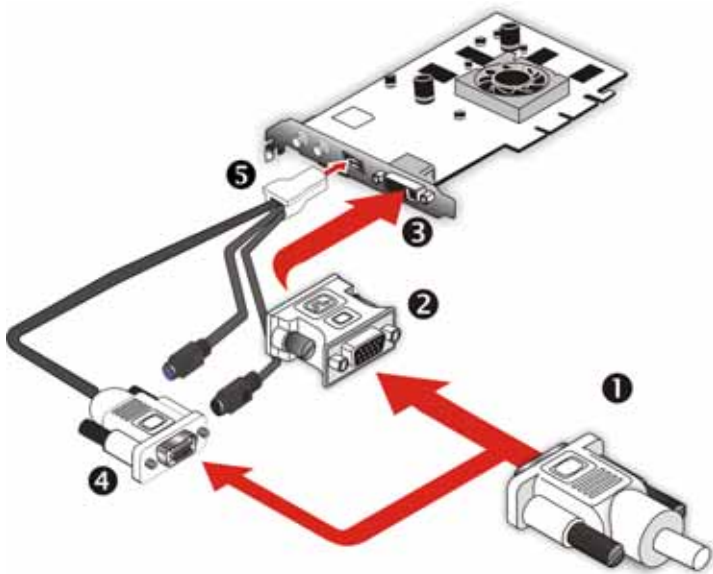

---

### Connections and Adapters for the All-in-Wonder® X800 PCI Express® Card

---

- ① **Standard VGA Monitor Connector.** To connect a VGA monitor to the DVI-I connector, plug the supplied DVI-I-to-VGA adapter into the DVI-I connector, then plug your monitor cable into the adapter.

---

- ② DVI-I-to-VGA Adapter (if necessary).

---

- ③ **DVI-I Backplate Connection.** To connect a flat panel, plug the monitor's DVI-I connector directly into the DVI-I connection.

---

- ④ **Honda/VGA adapter (included):** To connect a second VGA monitor, plug the second monitor into the VGA connection on the Honda/VGA adapter.

---

- ⑤ **Honda backplate adapter connection:** To enable a second monitor and provide a connection for TV (S-Video), plug the Honda/VGA adapter into the Honda backplate connection.

---

### *To connect your monitors*

- 1 **Turn off** your computer and monitors.
- 2 **Plug** the monitor cables into their appropriate connectors.
- 3 **Turn on** your monitors first, and then restart your computer so that Windows® can detect the new hardware settings.
- 4 When the **New Hardware Found** Wizard appears, at the appropriate prompt insert the ATI Installation CD to load the drivers for your All-in-Wonder® X800 PCI Express® card.

### *To set up a multi-monitor display*

- 1 From the **Start menu** click **Control Panel**, then **Display**. Click the **Settings** tab to access the basic multi-monitor configuration settings.

**Note:** ATI software provides many additional configuration features that can be accessed by clicking the **Advanced** button from the **Display Properties > Settings** tab.

- 2 Select the **Monitor** icon identified by the number **2**.

- 3 Click **Extend my Windows desktop onto this monitor**.
- 4 Set the **Screen Resolution** and **Color Quality** as appropriate for the second monitor. Click **Apply** or **OK** to apply these new values.

Refer to your Windows online help and documentation for further information on using the **Settings** tab.



When you use multiple monitors with your card, one monitor will always be Primary. Any additional monitors will be designated as Secondary.

## Display Configurations

Your All-in-Wonder® X800 PCI Express® graphics card provides dual display functionality and TV Out. The following table lists the different ways you can connect displays to your card.

Display Configuration	Connector(s) Used	Comments
Single CRT display	VGA connector OR DVI-I connector with DVI-I-to-VGA adapter	CRT- cathode ray tube analog display.
Single DFP display	DVI-I connector	DFP - digital flat panel display.
Single TV	S-Video Out	The S-Video Out can also support a composite connection via the S-Video-to-Composite adapter.
Single HDTV display	HDTV Output Adapter	HDTV - High Definition Television
CRT display + TV	VGA connector + S-Video Out	UNSUPPORTED CONFIGURATION if the CRT display is attached to the DVI-I connector via the DVI-I-to-VGA adapter.
CRT display + HDTV	VGA connector + HDTV (YPrPb) output cable	

<b>Display Configuration</b>	<b>Connector(s) Used</b>	<b>Comments</b>
<b>DFP display + TV</b>	DVI-I connector + S-Video out	
<b>DFP display + HDTV</b>	DVI-I connector + S-Video Out to HDTV (YPrPb) cable	
<b>CRT display + DFP display</b>	VGA connector + DVI-I connector	
<b>CRT display + CRT display</b>	VGA connector + DVI-I connector with DVI-I-to-VGA adapter	The DVI-I connector can support a CRT display using the DVI-I-to-VGA adapter
<b>CRT display + DFP display + TV</b>	VGA connector + DVI-I connector + S-Video Out	The TV display will "clone" the image of one of the other two displays
<b>CRT display + DFP display + HDTV</b>	VGA connector + DVI-I connector + HDTV (YPrPb) output cable	UNSUPPORTED CONFIGURATION
<b>CRT display + CRT display + TV</b>	VGA connector + DVI-I connector with DVI-I-to-VGA adapter + S-Video Out	
<b>CRT display + CRT display + HDTV</b>	VGA connector + DVI-I connector with DVI-I-to-VGA adapter + S-Video Out to HDTV (YPrPb) cable	UNSUPPORTED CONFIGURATION
<b>CRT display + European TV</b>	SCART + VGA Connector	
<b>DFP + European TV</b>	SCART + DVI-I	

Display Configuration	Connector(s) Used	Comments
European TV + TV	SCART + TV (S-Video / composite video)	UNSUPPORTED CONFIGURATION

## MultiView™

If you have an All-in-Wonder® X800 PCI Express® Series Series card and an ATI TV Wonder™ PCI card installed in the same system, MultiView™ lets you watch a different channel in a secondary video window. You can record video from your All-in-Wonder® X800 PCI Express® Series while you watch another channel on the TV Wonder™. The secondary window can be in the following locations:

- **Picture in Picture (PiP):** When the main video window is in full-screen, the MultiView™ PiP video window is embedded in the main window. It can be positioned in the top/bottom left or top/bottom right of the main window.
- **Picture outside Picture (PoP):** If you use only one monitor, the main and MultiView™ video windows can be displayed in separate windows. If you use dual monitors, you can drag the MultiView™ window to the secondary monitor. MultiView™ can be displayed in a window or full-screen in the secondary monitor.

MultiView™ controls include channel up/down, mute/unmute, audio, swap channel, volume slider, and channel status. When MultiView™ is in focus, you can also type a channel number or name to change channels.

### **To enable MultiView™**

In the MultiView™ Initialization Wizard, click **Enable MultiView™**.

### **To open and close MultiView™**

- 1 Right-click the control panel or the video panel.
- 2 In the Feature menu, click **Multiview**, and then click **Show**.

To close MultView™, click the Close button  or right-click the control panel or the video panel, and in the Feature menu, click **Multview**, and then click **Show**.

### ***To change the location of the MultView™ window***

When the main video window is in full screen, right-click the control panel or the video panel, click **Multview**, click **Location**, and then click the position you want: Top-Left, Top-Right, Bottom-Right, or Bottom-Left.

You can manually change the embedded window's size and location when the MultView™ borders are visible.

### ***Autohiding MultView™ window controls and borders***

The MultView™ window borders disappear after a few seconds of mouse inactivity on the MultView™ window. When you move your mouse over the MultView™ window, the border reappears.

Only one video window can be in control. When the embedded MultView™ window is in focus, its borders are red; when it is not in focus, its borders are black. For example when the borders are red, a Remote Wonder™ channel-change command will change the MultView™ channel.

## **MultView™ Audio Requirements**

If you have one audio card or an integrated audio chip, you must connect one audio path internally (CD-In, for example) and the other externally (Line-In, for example).

If you have two audio cards or one audio card and an integrated audio chip, you can connect both audio paths internally, externally, or one internally and the other externally.

## **EazyLook™**

Designed to work with the Remote Wonder™ in full-screen mode, EazyLook™ displays large, on-screen information about remote control functions when you watch TV, DVD, or File Player. It also provides assistance when you use the Library or navigate in TV Listings.

## CHAPTER 7:

# Reference

This chapter provides information on troubleshooting, where to get additional accessories, how to register your product, plus warranty and compliance information.

## Troubleshooting

The following troubleshooting tips may help if you experience problems. ATI's documentation contains helpful installation/configuration tips and other valuable feature information. Please contact your dealer for more advanced troubleshooting information.

### General Troubleshooting

Problem	Possible Solution
<b>Computer Does Not Boot-Up Properly</b>	<ul style="list-style-type: none"> <li>• Verify that the installation instructions were properly followed.</li> <li>• Check that the card is properly installed in your system and connected to your monitor.</li> <li>• If you have problems during start-up, restart your computer in <b>Safe Mode</b>. While starting Windows® XP, press and hold <b>F8</b> until you see the Windows® Advanced Options Menu. Use the arrow keys to select <b>Safe Mode</b>, and press <b>Enter</b>.</li> <li>• Check the system configuration utility of your operating system for the interrupt assignments.</li> <li>• Contact ATI's Customer Care or your local technical support.</li> </ul>

<b>General Troubleshooting</b>	
<b>Problem</b>	<b>Possible Solution</b>
<b>No Display</b>	<ul style="list-style-type: none"> <li>• Check that the card is seated properly in its expansion slot.</li> <li>• Ensure that the monitor cable is securely fastened to the card.</li> <li>• Make sure that the monitor and computer are plugged in and receiving power.</li> <li>• If necessary, disable any built-in graphics capabilities on your mother board. For more information, consult your computer's manual or manufacturer. (Note: some manufacturers do not allow the built-in graphics to be disabled or to become the secondary display.)</li> <li>• Make sure that you selected the appropriate monitor when you installed your enhanced driver.</li> </ul>
<b>Screen Defects Appear</b>	<ul style="list-style-type: none"> <li>• Check if your monitor supports the resolution, horizontal (kHz) and vertical (Hz) refresh rates as required by the graphics card.</li> <li>• Check your current resolution, refresh rate, and color depth settings in the <b>Settings</b> and <b>Monitor</b> tabs in your <b>Display Properties</b> dialog.</li> </ul> <p><b>Warning!</b> Ensure that both video card and monitor support resolution and refresh rates you select. Incompatible resolution/refresh rate selection may result in monitor damage. Refer to your monitor's documentation for recommended resolutions and refresh rates.</p>
<b>Off-Center Screen Image, Odd Colors or No Picture</b>	<ul style="list-style-type: none"> <li>• Try adjusting the brightness, sharpness, contrast, and color balance controls of your monitor.</li> <li>• Try adjusting the centering and positioning controls of your monitor to position the picture on the screen</li> <li>• Set the monitor's RGB inputs (and sync switches, if this option is available) to 75 Ohms, with the sync set to external.</li> <li>• Digital Flat Panel (DFP) monitor users: refer to your monitor's documentation for the appropriate cable and connector to plug into the DVI-I connector on the graphics card.</li> </ul>



## General Troubleshooting

Problem	Possible Solution
Operating System Warns that Video Card Isn't Properly Configured	<ul style="list-style-type: none"> <li>Check the driver installation and make sure that all software is correctly loaded corresponding to your operating system and applications.</li> <li>Re-install the ATI drivers for your All-in-Wonder® X800 PCI Express® card.</li> </ul>

## HDTV/HDTV Adapter Troubleshooting

Problem	Possible Solution
The colors on my TV display are incorrect	<ul style="list-style-type: none"> <li>Ensure that the connections between the Component Video Adapter and your HDTV are correct (Y=Green, Pb=Blue, Pr=Red).</li> </ul>
There is no display on my TV	<ul style="list-style-type: none"> <li>Your TV will not display anything until Windows starts; this may take several minutes.</li> <li>Set your TV to YPbPr input.</li> <li>Ensure that the HDTV Component Video Adapter is properly connected, then restart your computer.</li> </ul>
DVDs will not play in 720p or 1080i modes	<ul style="list-style-type: none"> <li>Copy-protected DVDs restrict playback to 480i and 480p modes.</li> </ul>
I can't see the entire display	<ul style="list-style-type: none"> <li>If your component input device supports it, try 720p mode.</li> </ul>
The display appears tilted	<ul style="list-style-type: none"> <li>Consult your HDTV user's manual.</li> </ul>
My CRT display is green	<ul style="list-style-type: none"> <li>Your system is in component output mode. Restart your computer with the CRT monitor connected.</li> </ul>

## Product Registration

To activate Customer Care you must register your product with ATI at:  
[ati.com/online/registration](http://ati.com/online/registration)

## Customer Care

For detailed instructions on how to use your ATI product, refer to the Online User's Guide included on your ATI installation CD-ROM.

If you require further assistance with your product, the following Customer Care options are available:

Service	Availability	Language	Access
<b>Online</b>  <b>or</b>  <b>Mail</b>	24/7	English, French, Spanish, Portuguese, German	<a href="http://ati.com">ati.com</a> or ATI TECHNOLOGIES INC. Attention: Customer Care 1 Commerce Valley Drive East Markham, Ontario Canada L3T 7X6
<b>Telephone US &amp; Canada</b>	9:00AM - 7:00PM EST. Monday to Friday.	English	1-877-284-1566 (toll-free)  or  1-905-882-2626 (International and/or local toll charges to Canada will apply).
<b>Telephone Europe and Other Regions</b>	10:30 to 00:00 GMT  10:30 to 19:00 GMT  12:00 to 20:30 GMT	English  German- French  Spanish- Portuguese	+00800-6677-1111 (toll-free)  or  +1-905-882-5549 (International and/or local toll charges to Canada will apply)
<b>Telephone Latin America / South America</b>	7:00AM to 3:30 PM EST  7:00AM to 7:00PM EST	Spanish, Portuguese  English	+0800-333-5277(Argentina)  +0800-891-9068 (Brazil)  +001800-514-3276 (Mexico)  other: +1-905-882-3277 (International and/or local toll charges to Canada will apply)

ATI Customer Care will work to resolve your issue and help you to get your ATI product up and running. If your issue is not resolved, our technicians will determine whether the difficulty you are experiencing is the result of the ATI product, whether your product contains a defect, and whether your product is under warranty.

- ATI Customer Care is unable to assist with refunds, returns, or exchange specific inquiries. If resolving the problem being experienced is critical to your decision to keep the product, it is your responsibility to ensure that you know and are within the period of time your reseller will allow for refunds, returns or exchange.
- ATI is not responsible for any expense incurred accessing Customer Care. It is expected that customers will review the expense associated with the available support options and will choose the method that best meets their needs and budget.
- ATI Customer Care reserves the right to limit support options for products that are not registered or are at End of Life.

## Warranty Information

### Hardware Warranty Service Statement

ATI Technologies Inc. warrants to the original purchaser of the hardware that the product is in good working condition, according to its specifications at the time of shipment, for a period of three years from the date of original purchase.

Should the product, in ATI's opinion, malfunction within the warranty period, ATI will, at its discretion, repair or replace the product upon receipt with an equivalent. Any replaced parts become the property of ATI. This warranty does not apply to the software component of the installation, usage not in accordance with product specifications and instructions, natural or personal disaster, or unauthorized alterations, repairs, or modifications.

Proof of purchase may be required, if doubt exists regarding warranty eligibility. Late model products are assumed to be under warranty. ATI accepts originals, photocopies and faxes as proof of purchase when required

### Warranty Service

For warranty service instructions visit:

[ati.com/online/warranty](http://ati.com/online/warranty) or contact one of our Customer Service Representatives using one of the aforementioned means.

- Before shipping any unit for repair, obtain an RMA number for warranty service.
- When shipping your product, pack it securely, show the RMA and serial number of the product on the outside, and ship prepaid and insured.
- ATI will not be held liable for damage or loss to the product in shipment.

- Standard warranty service consists of repair upon receipt.
- ATI reserves the right to replace the product with a serviced product at their sole discretion at any time.
- You are responsible for the cost of shipping the product to ATI. ATI plays the cost of returning the product to you.

Products which are repaired under warranty are guaranteed for the remainder of the original warranty period. Repairing or exchanging a product does not start a new warranty period. If, at the time of repair, a product is already "out of warranty" or within the last 90 days of the warranty period, ATI will guarantee the repair for the full 90 days. All other terms and conditions of the original warranty apply.

## Limitations

- This warranty is valid only if the online Product Warranty Registration form at: [ati.com/online/registration](http://ati.com/online/registration) is successfully submitted within 30 days of purchase of said product.
- All warranties for this product, expressed or implied, will expire three (3) years\* from date of original purchase.
- All accompanying cables and accessories are warranted for 90 days.
- No warranties for this product, expressed or implied, shall extend to any person who purchases the product in a used condition.
- The liability of ATI in respect of any defective product will be limited to the repair or replacement of such product. ATI may use new or equivalent-to-new replacement parts. Defective product will be sent in for repair or replacement only. ATI makes no other representations or warranties as to fitness for a particular purpose, merchantability or otherwise in respect of the product. No other representations, warranties or conditions, shall be implied by statute or otherwise. In no event shall ATI be responsible or liable for any damages, including but not limited to the loss of revenue or profit, arising:
- From the use of the product, as a result of any event, circumstance, action or abuse beyond the control of ATI; whether such damages be direct, indirect, consequential, special or otherwise and whether such damages are incurred by the person to whom this warranty extends or a third party
- From the loss of use of the product, as a result of any event, circumstance, action or abuse beyond the control of ATI; whether such damages be direct, indirect, consequential, special or otherwise and whether such damages are incurred by the person to whom this warranty extends or a third party.
- Unauthorized repairs to an ATI board level product will void the warranty offered by ATI Technologies. ATI reserves the right to refuse to service any product which has been altered, modified, or repaired by non-ATI service personnel.

## Getting Additional Accessories

Additional and replacement cables, installation CD-ROMs, manuals, and other accessories for ATI products can be purchased from the online ATI store at:

[ati.com/online/accessories](http://ati.com/online/accessories)

# Compliance Information

This section details the compliance information for this product.

## FCC Compliance Information

This All-in-Wonder® X800 PCI Express® Series product complies with FCC Rules part 15. Operation is subject to the following two conditions

- This device may not cause harmful interference, and
- This device must accept any interference received, including interference that may cause undesired operation.

This equipment has been tested and found to comply with the limits for a Class B digital device, pursuant to Part 15 of the FCC Rules. These limits are designed to provide reasonable protection against harmful interference in a residential installation. This equipment generates, uses and can radiate radio frequency energy and, if not installed and used in accordance with manufacturer's instructions, may cause harmful interference to radio communications. However, there is no guarantee that interference will not occur in a particular installation. If this equipment does cause harmful interference to radio or television reception, which can be determined by turning the equipment off and on, the user is encouraged to try to correct the interference by one or more of the following measures:

- Re-orient or relocate the receiving antenna.
- Increase the separation between the equipment and receiver.
- Connect the equipment to an outlet on a circuit different from that to which the receiver is connected.
- Consult the dealer or an experienced radio/TV technician for help.

The use of shielded cables for connection of the monitor to the graphics card is required to ensure compliance with FCC regulations. Changes or modifications to this unit not expressly approved by the party responsible for compliance could void the user's authority to operate this equipment.

## Industry Canada Compliance Statement

ICES-003 This Class B digital apparatus complies with Canadian ICES-003.

Cet appareil numérique de la Classe B est conforme à la norme NMB-003 du Canada.

For further compliance information:

ATI Research Inc.  
4 Mount Royal Ave.  
Marlborough, MA  
01752-1976  
USA  
508-303-3900

## CE Compliance Information

EMC Directive 89/336/EEC and amendments 91/263/EEC, 92/31/EEC and 93/68/EEC, Class B Digital Device EN 55022:2003/CISPR 22 Class B, Limits and Methods of Measurement of Radio Interference Characteristics Information Technology Equipment.

EN 55024:1998/CISPR 24:1997 +A1:2001 +A2:2003, Immunity of Information Technology Equipment (ITE), including EN 61000-4-2, EN 61000-4-3, EN 61000-4-4, EN 61000-4-5, EN 61000-4-6

## Informations de conformité de la CE

Directive EMC 89/336/CEE et amendements 92/31/CEE et 93/68/CEE, pour dispositif numérique de Classe B.

EN 55022:2003/CISPR 22:1997, - Classe B - Limites et méthodes de mesure des caractéristiques d'interférences radiophoniques, Matériel des technologies de l'information.

EN 55024:1998/CISPR 24:1997 +A1:2001 +A2:2003, Norme sur l'immunité de matériel des technologies de l'information, et comprenant EN 61000-4-2, EN 61000-4-3, EN 61000-4-4, EN 61000-4-5, EN 61000-4-6

## Electrical Safety

73/23/EEC - The Low Voltage Directive

IEC 60950-1:2001, IEC 60950:1999, 3rd Edition - Safety of Information Technology Equipment

BS EN60950-1:2002, BS EN60950:2000, 3rd Edition UL 60950-1:2003, UL 60950:2000, 3rd Edition CAN/CSA C22.2 No. 60950-1:2002, CAN/CSA C22.2 No. 60950-00, 3rd Edition (2000)

To meet UL safety requirements, the computer's maximum room temperature should not exceed 40° C.



## Waste Electrical and Electronic Equipment (WEEE) Directive Compliance

This product was manufactured by ATI Technologies Inc.







# Index

## Numerics

102 part number 2

3D 23, 26

480i 41

480p 41

720p 41

## A

accessories 44

adapters

*compatibility with earlier products* 12

*input and output* 9

Advanced View 21, 23, 24

ATI Overdrive 3 25

ATIS SETUP utility 17

## B

Basic View 21

brightness 23, 40

## C

Catalyst Control Center 19, 25, 26, 27

Cathode Ray Tube (CRT) 25

Color 17, 23, 40

Compliance Information 45

compliance information 39

Component Video Properties 24

configuration

*primary monitor* 17

configuration tips 39

contrast 23, 31, 40

*TV display* 31

Control Panel 4, 17, 30

Copy-protection

*DVDs* 41

CRT 41

Customer Care 39, 41, 42, 43

## D

Dashboard 19, 27

Detailed installation 6

Digital 40

Digital Flat Panel (DFP) 40

- Digital Panel properties 24
- Direct 3D 23
- Display Configurations 35
- display configurations 35
- Display Data Channel (DDC) 24
- Display Detection Options 23
- Display devices
  - connecting* 7
- display devices
  - multiple* 33
- Display Options 23
- displaying PC output on HDTV 11
- displaying PC output on TV 10
- Displays Manager 21
- Dot pitch 31
- dot pitch 31
- driver installation 15
- drivers
  - installing* 15
  - uninstalling* 4
- DVI 24
- DVI-I 40
- E**
- EazyLook™ 38
- Extended Display Identification Data (EDID) 24
- F**
- FCC Compliance 45
- Force TV Detection 23
- Fullscreen 23
- Fullscreen modes 23
- G**
- games
  - TV display* 31
- gamma 23
- Getting Additional Accessories 44
- Getting started 1
- H**
- Hardware
  - installing* 5
- HDTV Adapter Troubleshooting 41
- Help 4, 19, 21, 27, 30, 43
- High Definition Television (HDTV) 24, 25, 41
- horizontal size
  - TV display* 31
- Hotkeys Manager 25

HydraVision™ 16  
HYDRAVISION™ 16

**I**

Industry Canada Compliance 45  
input and output adapters 9  
input/output adapter 12  
Installation  
    *detailed* 6  
installation tips 39

**M**

Multimedia Center  
    *starting* 18  
multi-monitor 21  
multiple displays 33  
MultiView™ 37  
    *audio requirements* 38  
    *Picture in Picture, Picture outside Picture* 37  
    *TV Wonder™* 37

**O**

OpenGL 23

**P**

PCIe drivers  
    *chipset drivers* 3  
Picture in Picture 37  
Picture outside Picture 37  
Preferences 26  
Product Registration 41  
profiles 26  
Profiles Manager 26

**R**

recording PC output on videotape 10  
Red Green Blue (RGB) 40  
Refresh Rate 17, 23, 40  
Refresh Rate Override 23  
registration 2  
Resolution 17, 31, 40

**S**

Safe Mode 39  
safety instructions iii  
serial number 2  
Software  
    *installing* 15  
Special Multimedia Center features  
    *EazyLook™* 38  
system requirements 2

**T**

- Troubleshooting 39, 41
  - HDTV adapter* 41
- troubleshooting 39
- TV 21, 23, 29, 30, 31, 41
  - MuTVView™* 37
- TV display 29, 31
  - contrast* 31
  - games* 31
  - hardware restrictions* 30
  - horizontal size* 31
- TV Out 29, 30
- TV Wonder™ 37

**V**

- Video 23, 24, 41

**W**

- Warranty 43
  - warranty 39
  - Waste Electrical and Electronic Equipment (WEEE) Compliance 46
  - watch movies on PC
    - record video from VCR or camcorder* 9
  - Widescreen mode 23
  - Windows 17, 41
  - Windows Advanced Options Menu 39
  - Windows XP 39
  - Wizard 21
- Y**
- YPbPr 41