

Ergonomic Guidelines

Recommended Mounting Position

- When mounting the Spacedec Acrobat Articulated Arm, ensure the correct focal distance can be achieved for ultimate visual comfort (Refer to Recommended Viewing Distance / Height below)

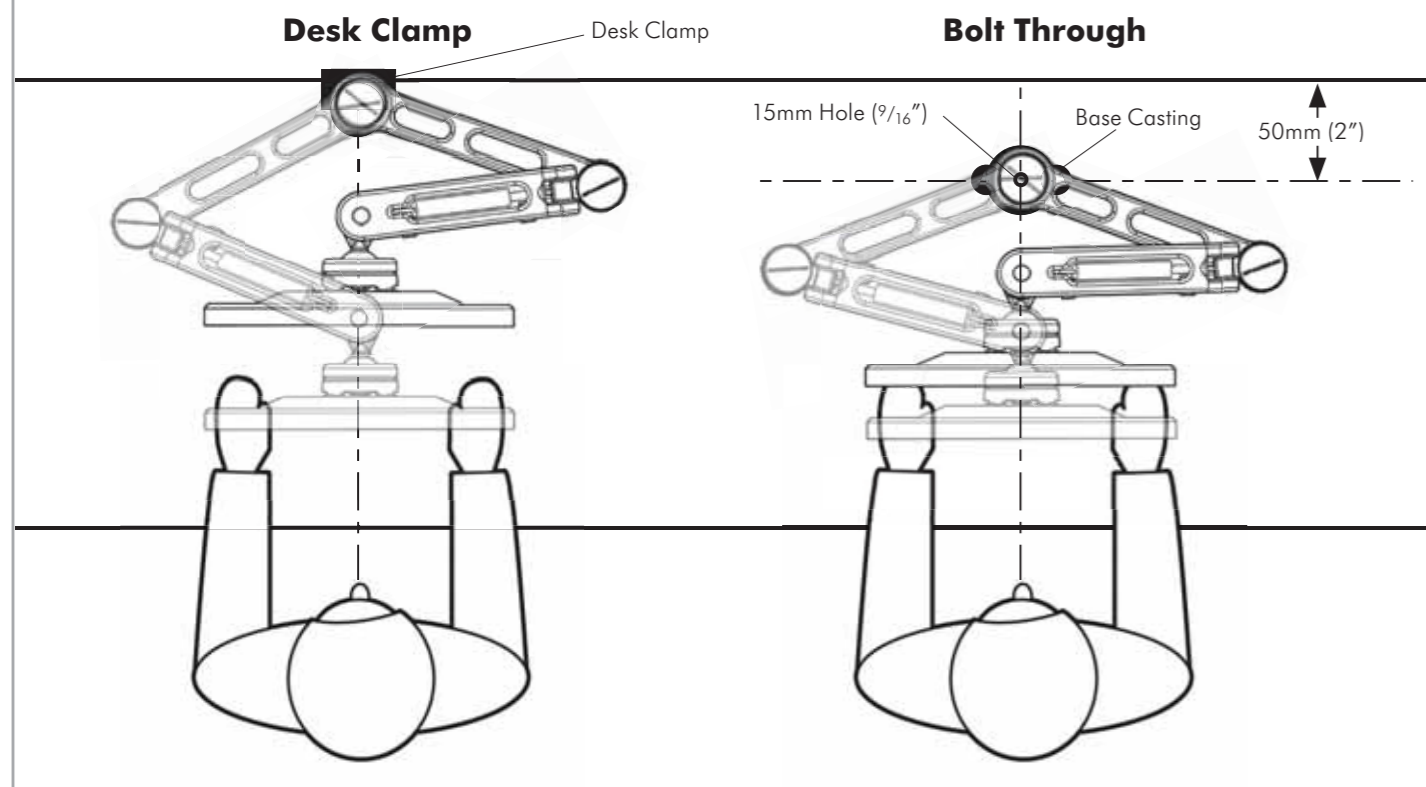

Recommended Viewing Distance / Height

- Ergonomists recommend that the optimal position of your screen should be slightly below eye level. When looking at the screen's centre the user should have a downward visual angle of approximately 10°-20°. As a guide, the height (h) of your display should approximately be as follows:

- Tall Male (Max): 560mm (22")
- Tall Female (Max): 520mm (20 1/2")
- Short Male (Min): 368mm (14 1/2")
- Short Female (Min): 356mm (14")

- For visual comfort, a viewing distance (d) between 500mm (19 1/2") to 750mm (29 1/2") is recommended.

- Angular adjustments to reduce reflection on your monitor should range between 5° forward tilt to 15° backward tilt.

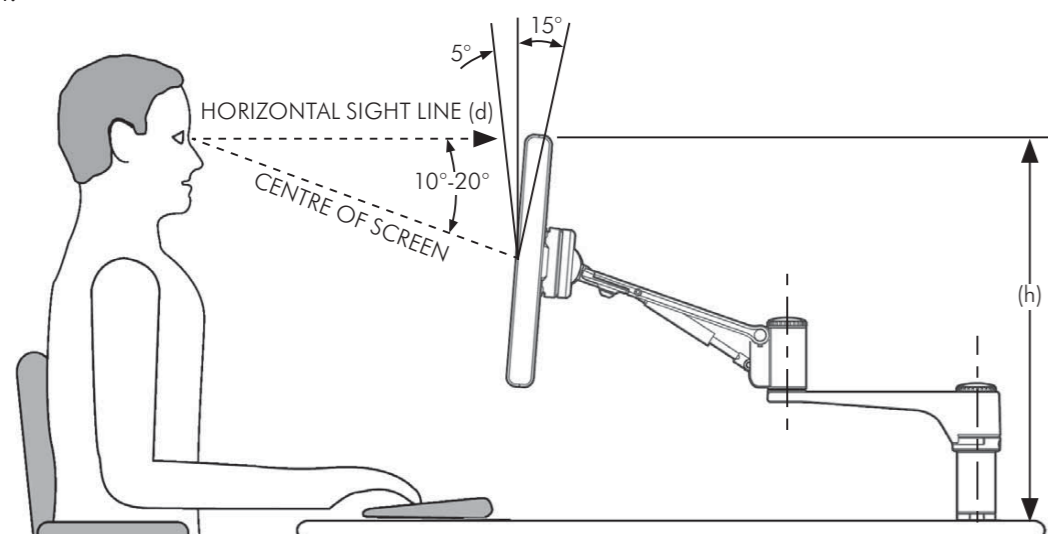

Adjusting the Display

The Acrobat Articulated Arm comes factory set to support 6kg displays. Adjust the arm to suit the weight of your display as shown in the following steps:

H.1. Adjusting the Ball Joint Resistance

Depending on the weight of the monitor, it may be necessary to make adjustments to the Ball Joint Mechanism. If the monitor doesn't hold its position or is too resistant, adjust the four tension screws located around the Ball Joint (see diagram on the right) using the supplied 2.5mm Allen Key.

Check the display, and then adjust again if necessary.

NOTE: Be sure to adjust screws evenly.

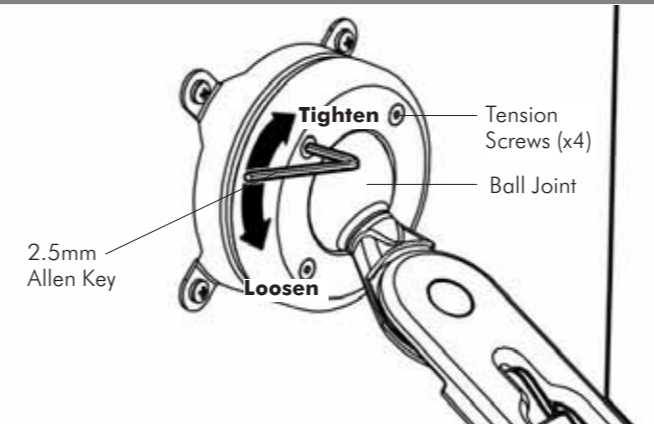

H.2. Adjusting the Pivot Head Resistance

It is possible to control the amount of resistance in the Pivot Head to suit your display.

To increase the resistant of the Pivot Head to suit heavier displays, use the 5mm Allen Key supplied in the Desk Clamp Box to tighten the interscrew in a clockwise direction.

To decrease the resistance of the Pivot Head to suit lighter displays, loosen the interscrew in an anti-clockwise direction.

NOTE: It is recommended the Pivot Head be left at the factory setting for best performance.

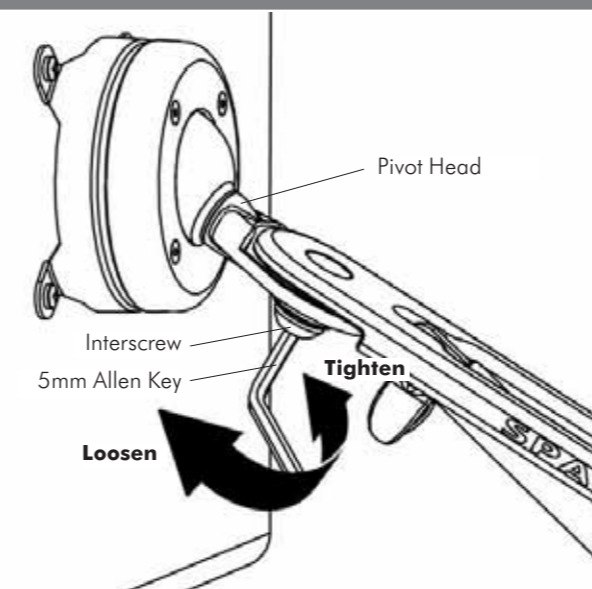

H.3. Adjusting the Articulated Arm/Gas Strut Resistance

H.3.1. Depending on the weight of the monitor, it may be necessary to adjust the arm. This can be done by using the 5mm Allen Key supplied in the Desk Clamp Box.

H.3.2. If the arm tends to automatically rise or fall when the display is attached, it will be necessary to make small adjustments to the gas strut. (see diagram on the right)

H.3.3. If the arm tends to rise, the gas strut position should be raised. If the arm tends to fall, the gas strut position should be lowered.

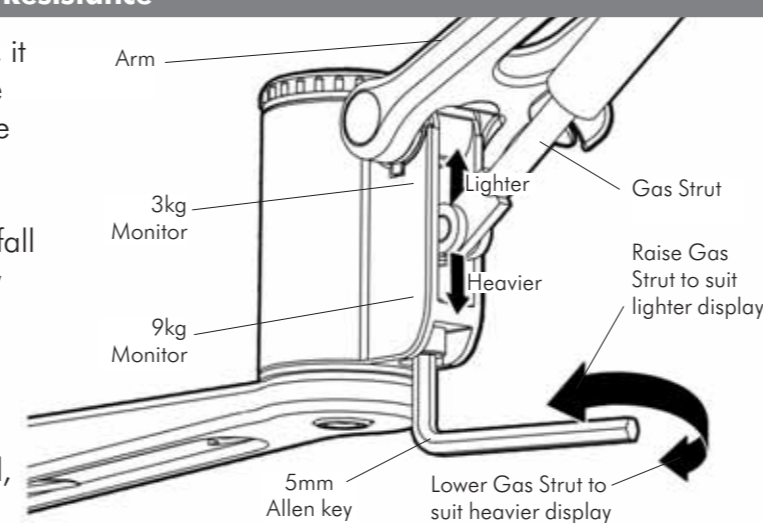

Installation Complete



As LCD Manufacturers are constantly releasing new monitor models, Atdec does not accept responsibility if the mounting hole pattern does not comply with the international VESA standards. Due to continuing product development, the manufacturer reserves the right to alter specifications without notice. Published: 12.04.07

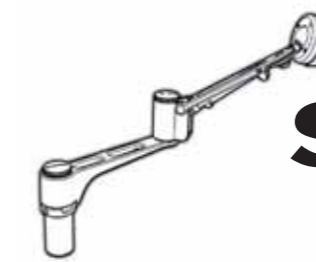

Installation Instructions

SPACEDEC ACROBAT

ARTICULATED ARM

Component Checklist

Single Arm

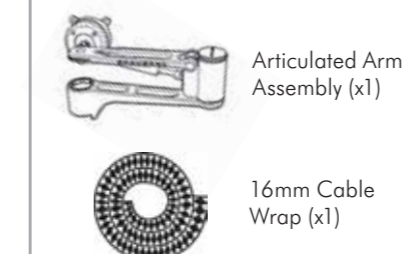

Tube Assembly (x1)

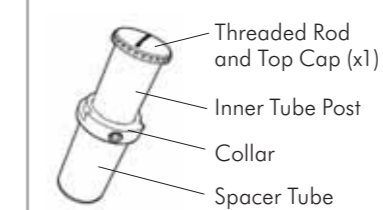

Bits Box

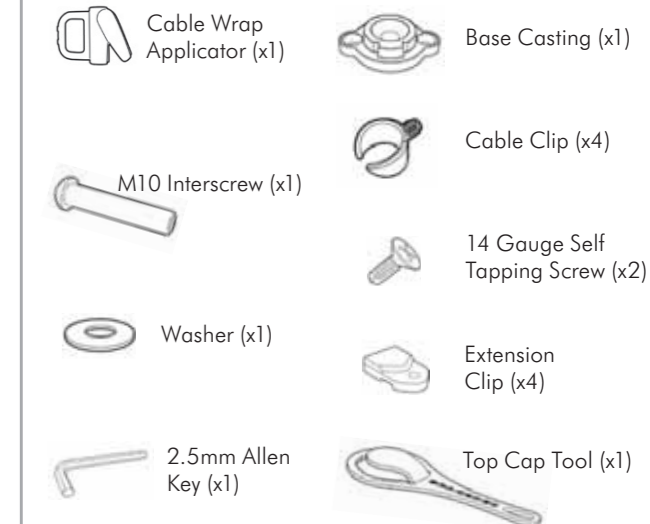

Desk Clamp Box

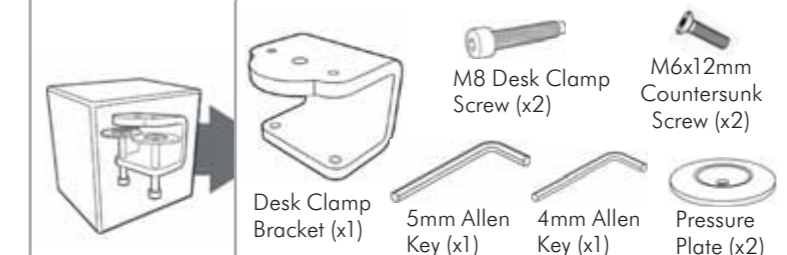

Mounting Fasteners



A Component Checklist

Check you have received all parts against the Component Checklist above.

B Assembling the Arm

B.1. Disassemble the Tube Assembly

In order to attach the Articulated Arm to the tube assembly you will need to remove the Top Cap and Threaded Rod as shown:

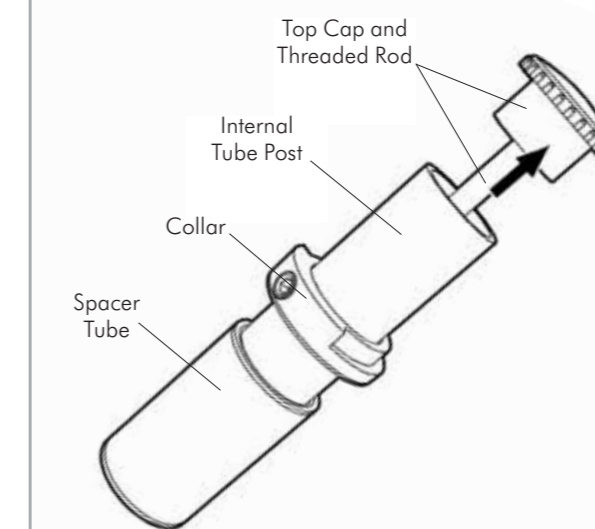

B.2. Assemble the Articulated Arm

Assemble the Articulated Arm as shown:

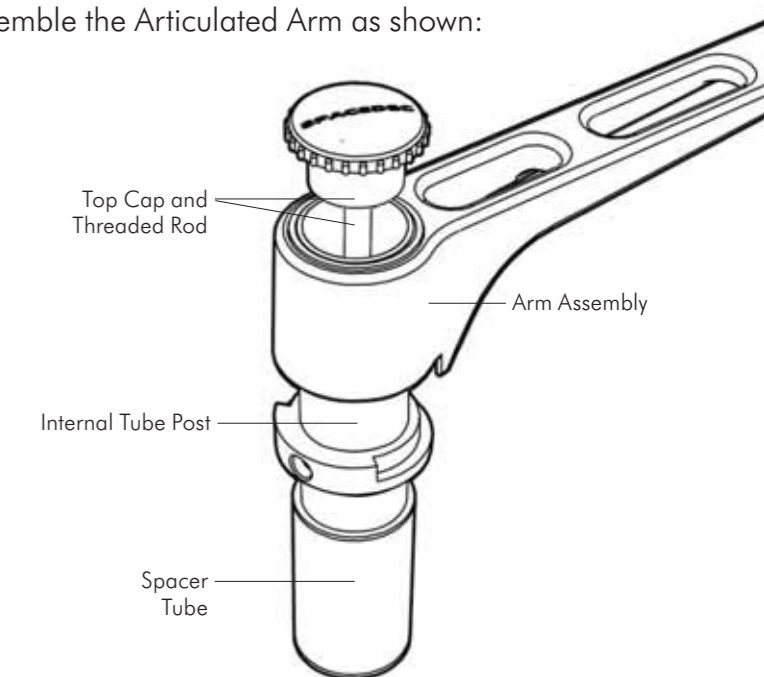

C Mounting Options

There are two Mounting Options: **Desk Clamp** and **Bolt Through**
 To use the **Bolt Through** system (Suits desktop thicknesses of 12mm-40mm [1/2"-1 1/2"]) follow the Bolt Through instructions at **C.1**. To use the **Desk Clamp** (Suits desktop thicknesses of 12mm-38mm [1/2"-1 1/2"]) follow the Desk Clamp instructions at **C.2**.

C.1. Bolt Through

C.1.1. Base Casting

The Articulated Arm is limited to 180° rotation. This is determined by the location of the Base Casting, as shown.

When mounting the Base Casting, ensure that the Articulated Arm is free to achieve its full 180° range of movement.

If mounting the Base Casting in a 90° corner, position the casting to ensure that the Articulated Arm can only make contact with one side of the corner.

The Base Casting should be mounted no less than 50mm (2") from the edge of the desk.

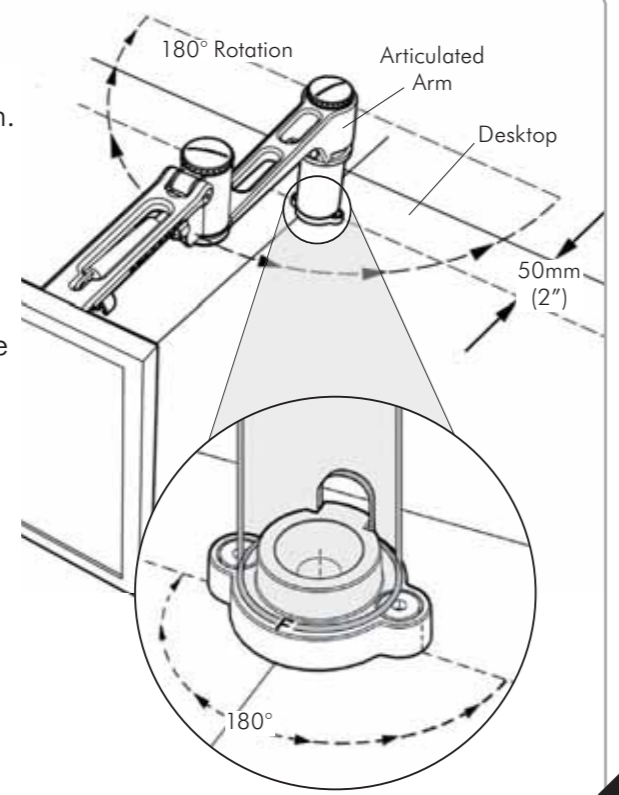

C.1.2. Drill Mounting Hole

Position the Base Casting on the desk in the desired location ensuring that the letter "F" faces the user. Using the base casting position, locate and mark the holes (x3) for drilling.

Drill the holes and then secure the Base Casting to the desk using the supplied 14 Gauge Self Tapping Screws (x2).

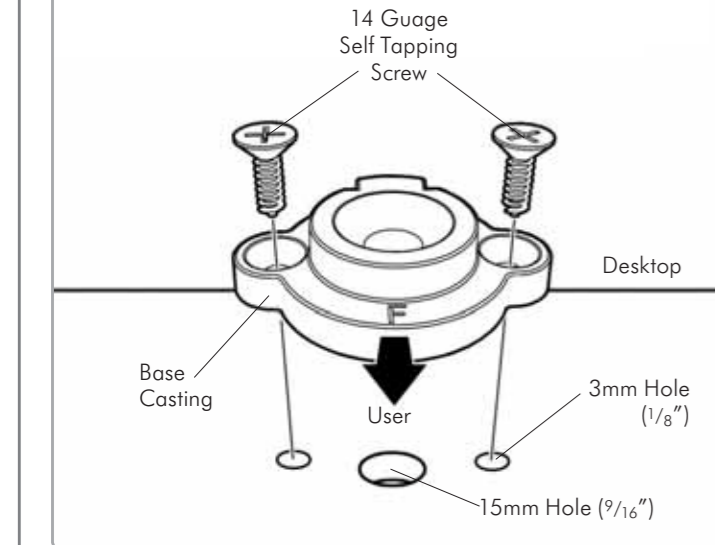

C.1.3. Installing the Articulated Arm

Insert the M10 Interscrew up through the hole in the work surface.

Using both hands, secure the M10 Interscrew with the 5mm Allen Key and use the other hand to tighten the Threaded Rod into the Interscrew with the supplied Top Cap Tool.

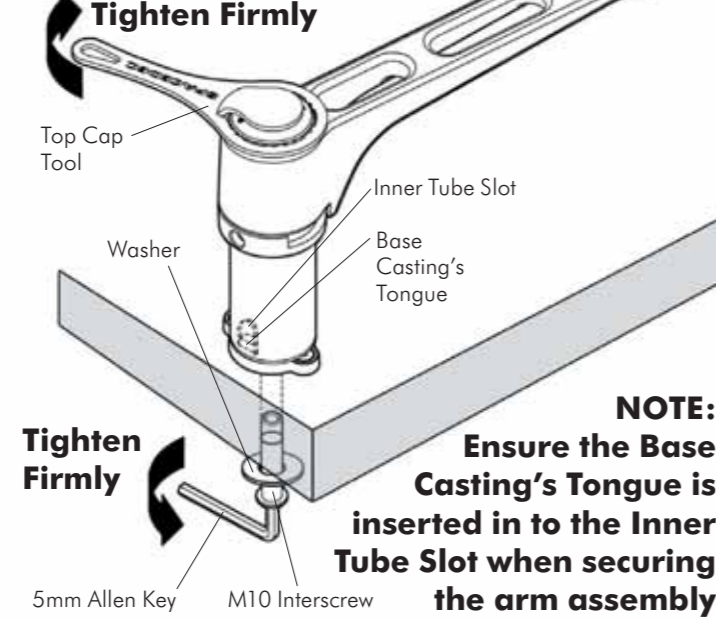

C.2. Desk Clamp

C.2.1. Assemble Desk Clamp

Place the Base Casting on top of the Desk Clamp ensuring the "F" is facing towards the user. Using the 4mm Allen Key, attach the Base Casting to the clamp by inserting the supplied M6x12mm Countersunk Screws (x2) into the holes in the Base Casting as shown.

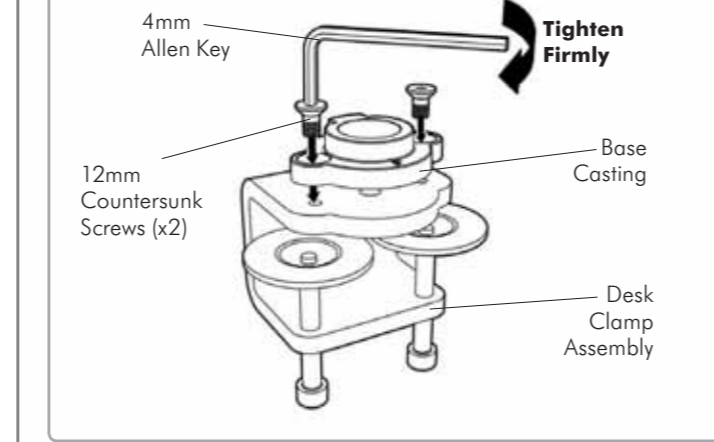

DESK CLAMP ADJUSTMENT RANGE

Suits 12mm (1/2") to 38mm (1 1/2") thick Work Surfaces

Pressure Plate (x2)

M8 Desk Clamp Screw (x2)

NOTE: It is recommended that the Desk Clamp be attached to the rear or side edge of the work surface

Adjust the Desk Clamp to suit your desk thickness by turning the M8 Desk Clamp Screw with the supplied 5mm Allen Key.

C.2.2. Attaching the Desk Clamp

Place the Desk Clamp in the desired position on the edge of the dektop and secure in place using the supplied 5mm Allen Key as shown in diagram.

C.2.3. Attaching the Articulated Arm

Use the Top Cap Tool to tighten the Threaded Rod into the Base Casting as shown.

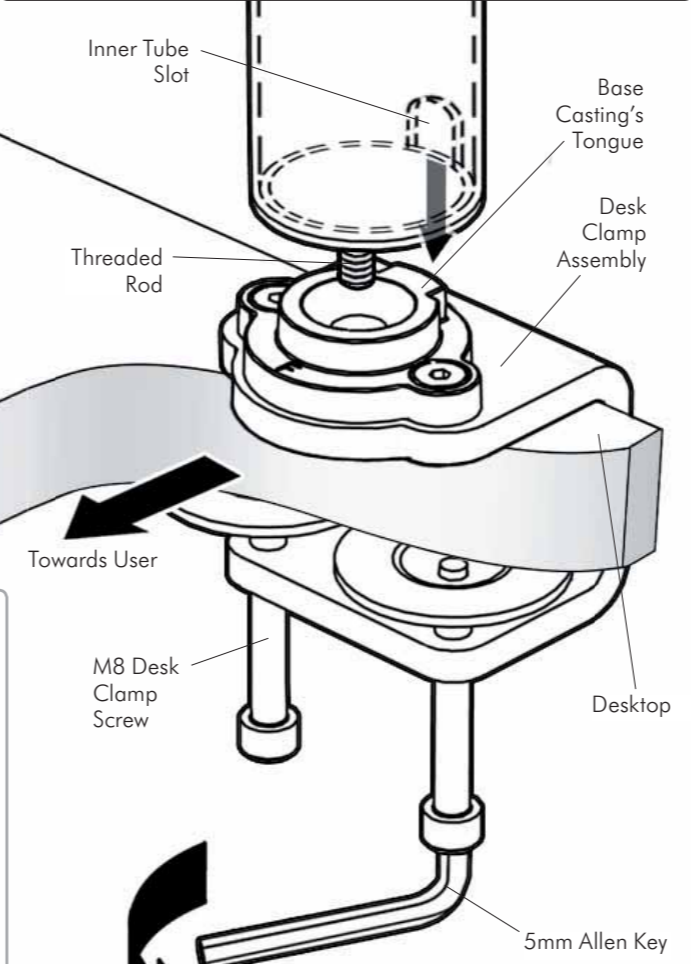
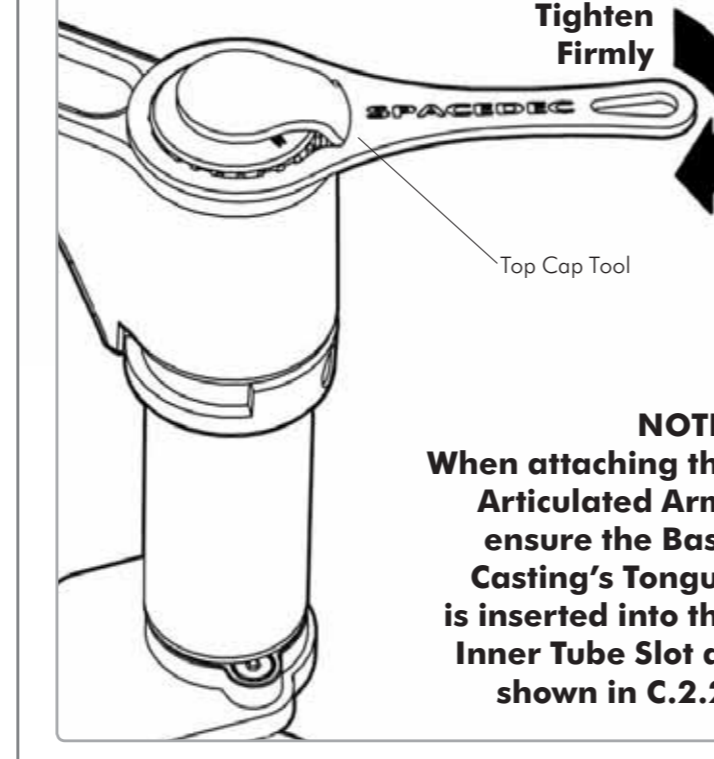

NOTE: Desk Clamp Assembly is Suitable for square edged desks only

D Attaching the Display

Direct Mount Configuration

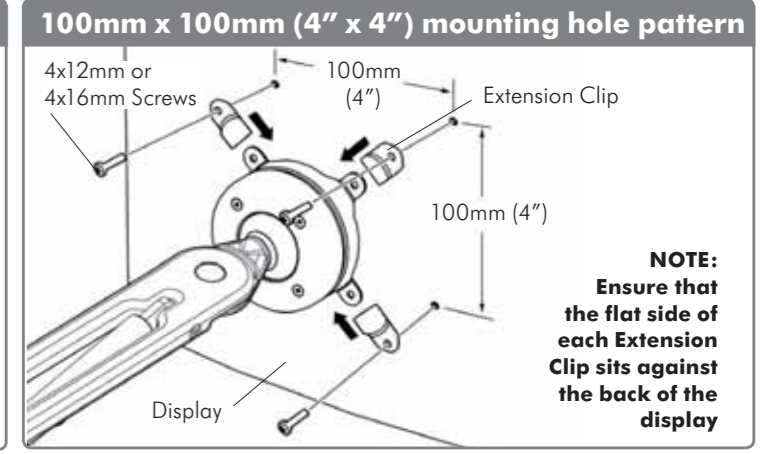
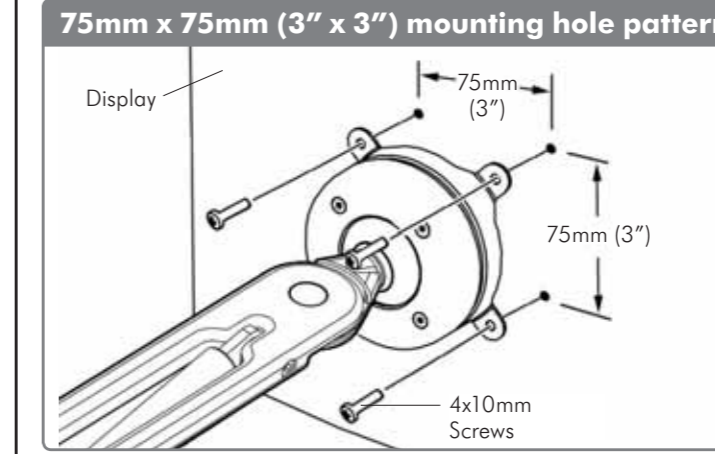

E Installing Cable Management

- E.1.** Push the four supplied Cable Clips into the holes on the underside of the arm as shown in diagram
- E.2.** Feed the cables into the Cable Wrap Applicator.
- E.3.** Insert the Cable Wrap Applicator into the Cable Wrap as shown.
- E.4.** Squeeze the nose of the Applicator and place inside the Cable Wrap ensuring that the opening edges of the Cable Wrap face towards the nose of the applicator as shown in diagram.

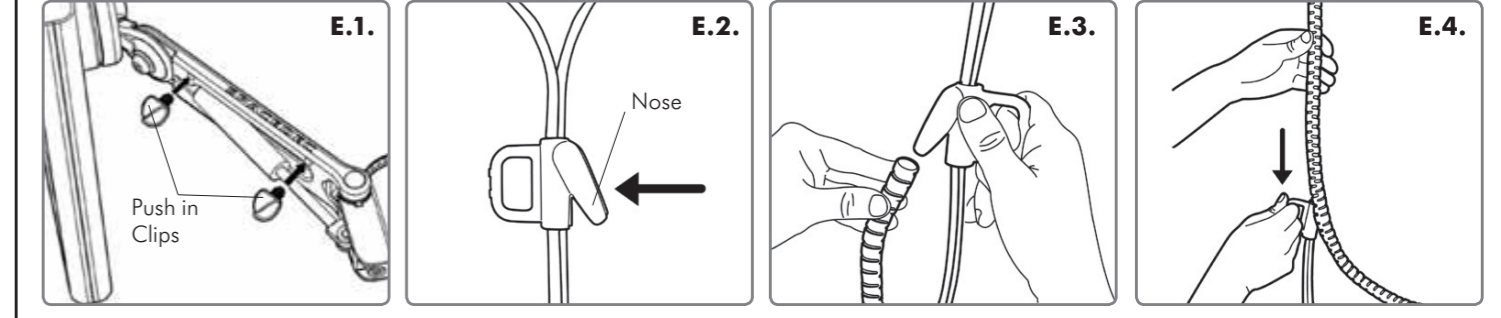

F Attaching the Cable Wrap to the Arm

- F.1.** Position the display at its highest possible position to ensure that there is sufficient cabling at the end of the arm so the cables are not stretched or pulled out when the display is moved.
- F.2.** Clip the cable wrap into the four Cable Clips as shown in diagram.

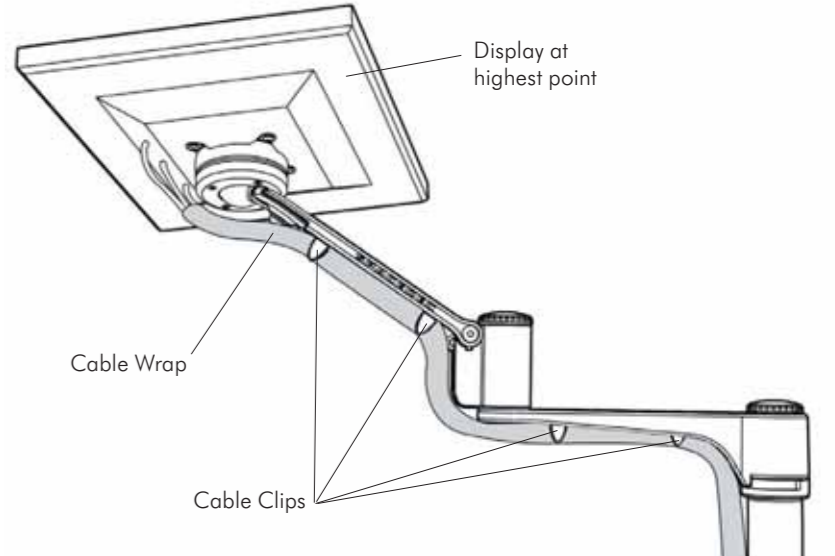

BEFORE PROCEEDING TO THE NEXT STEP PLEASE NOTE: Articulated Arm will only work when a display is properly installed. **DO NOT** adjust tension screws or gas strut until your display has been attached.