

addIT A720/A723 Series

User Guide





ADCON TELEMETRY GMBH
I N K U S T R A S S E 2 4
A-3400 KLOSTERNEUBURG
A U S T R I A

TEL: +43 (2243) 38 280-0
FAX: +43 (2243) 38 280-6
<http://www.adcon.at>

Proprietary Notice:

The Adcon logo, the A720 and A730 series, addIT™, the A840 series, addVANTAGE®, addVANTAGE Lite and addVANTAGE Pro are trademarks or registered trademarks of Adcon Telemetry. All other registered names used throughout this publication are trademarks of their respective owners.

Neither the whole nor any part of the information contained in this publication may be reproduced in any material form except with the prior written permission of Adcon Telemetry.

This publication is intended only to assist the reader in the use of the product. Adcon Telemetry shall not be liable for any loss or damage arising from the use of any information in this publication, or any error or omission in such information, or any incorrect use of the product.

Document Release 2.0, August 2000
Copyright ©1999-2004 by Adcon Telemetry GmbH.
All rights reserved.

Contents

Contents	3
Chapter 1. Introduction	5
What are addIT devices?	5
Installation issues	6
Conventions	7
Chapter 2. Using the Base Station	9
Opening the packages	9
Installing the base station	10
Installing the receiver	10
Installing the power supply	11
Replacing the fuse	12
Configuring the software	12
Chapter 3. Using the RTU	13
Opening the packages	13

Installing the RTU _____	14
More about the LED tool _____	16
Configuring an addIT RTU in the addVANTAGE software _____	17
Maintaining and servicing the RTU _____	17
The RTU battery _____	17
Changing the battery _____	18
Chapter 4. Performing Advanced Functions _____	21
Device series _____	22
Understanding connectors _____	22
The receiver connector _____	22
The RTU connectors _____	23
Configuring the devices _____	24
Serial communication protocol _____	25
General format of a command _____	25
General format of an answer _____	25
Using terminal commands _____	26
Series 1 devices _____	26
The SET series of commands _____	26
Querying the actual configuration parameters _____	29
Series 2 and 3 devices _____	30
Notifications _____	53
Returned errors list _____	54
Command line interpreter _____	54
Device descriptors and storage handler _____	54
Real time clock _____	54
Radio interface _____	54
Notifications _____	55
Appendix. Specifications _____	57
Index _____	61
Credits and Colophon _____	65

Chapter 1. Introduction

This manual explains the hardware aspects of Adcon's addIT™ A72xx series, including installation issues and certain parameter configurations. The manual is divided into these chapters:

- "Introduction," which gives some general information and document conventions.
- "Using the Base Station," which details the installation and use of the receiving unit.
- "Using the RTU," which details the installation and use of the remote telemetry unit.
- "Performing Advanced Functions," which discusses technical information for the advanced user.

What are addIT devices?

Adcon's addIT devices (A720, A723 and A720B) are uniquely suited to your remote measuring needs. The A720 and A723 devices are remote telemetry units (RTU) that can be used with Adcon and other compatible sensors to track those parameters important to you. And the A720B device, in conjunction with your computer, is a base station that offers many ways for you to view and manipulate the data received from the RTUs.

The addIT A720/A723 RTU can be used in one of the following ways:

- Installed in the vicinity of an Adcon remote measuring station (A730MD), the addIT RTU can use the A730MD station to relay its data to a base station (A730SD or A840). If the base station is close enough to the addIT RTU, the RTU can communicate directly with the base station.
- As a standalone device, the addIT RTU communicates directly with the addIT base station (A720B).

The addIT A720B base station works with up to three addIT RTUs, storing the data it receives until you download it to your computer.

Installation issues

The following restrictions apply:

- In general, the maximum “line-of sight” distance an addIT RTU can communicate is 800 m (approximately half a mile). This is valid if the partner device is mounted on a 3 m mast (9 ft.) and the RTU is mounted on a 30 cm mast (1 ft.); the results may vary under different conditions.
- As with all wireless communication devices, the higher the transmitter is, the better the communication will be. Mountainous or hilly terrain makes for poor communication.
- When using the addIT RTU with an A730 system, Adcon strongly recommends limiting the number of RTUs to under 6 per A730MD station in order to avoid exhausting the station’s battery, especially during the winter. However, you can have as many RTUs as you want if they are directly connected to the base station.

Note: Your local conditions may vary. If you are located closer to the Equator, the maximum obtainable energy is greater than that at the Poles and it may be possible to “hang” more addIT devices per station.

- When using the addIT RTU in a standalone system (that is, with an A720B base station), you are limited to a maximum of three RTUs per base station.
- addIT RTUs cannot route data. They can communicate with either the A730SD, A840 or A720B base station, or with an



A730MD remote station, but they cannot communicate with each other.

- All addIT devices accept the standard Adcon sensors; however, the connectors are different. Waterproof connectors are used to provide IP65 class protection. All new sensors will be delivered with this new connector. A special adapter will be supplied to connect new sensors to RJ-12 ports of the A730MD stations.

Note: For technical reasons, Adcon cannot provide adapters for the RJ-12 connector to the addIT devices.

Conventions

Certain conventions apply in this documentation.

<i>Italics</i>	Indicate the text is variable and must be substituted for something specific, as indicated in the explanation. Italics can also be used to emphasize words as words or letters as letters.
Bold	Indicates special emphasis of the text. Also indicates menu names and items in a window.
<code>fixed font</code>	Indicates characters you must type or system messages.
File ▶ Save	Indicates menu selection. For example, select the File menu, then the Save option.
Note	Indicates information of interest. Notes appear after the information they apply to.
 CAUTION	Indicates that you may get unexpected results if you don't follow the instructions. The graphic symbol appears next to the paragraph the Caution applies to, and the Caution text follows the paragraph.
 WARNING	Indicates danger to yourself or damage to the device if you don't follow the instructions. The graphic symbol appears next to the paragraph the Warning applies to, and the Warning text follows the paragraph.

Chapter 2. Using the Base Station

Your addIT base station consists of the receiver (A720B), the power supply (A720PS), and addVANTAGE Lite software.

Note: If you are using the addIT RTU as part of an A730 system, this chapter does not apply to you. For information about the addIT RTU, see "Using the RTU" on page 13. For information about installing an A730 base station, refer to the addVANTAGE A730 User Guide or the addVANTAGE A730 Releases Notes for Version 3.35.

Opening the packages

You get several boxes when you purchase the addIT base station. When you open them, you'll see they contain:

- The A720B receiver and ring clamp
- The A720PS power supply, serial cable, and power cord
- The 30-meter (approx. 99 ft) base station communication cable
- The addVANTAGE Lite software on a CD-ROM

Make sure you've received all the equipment and read through the instructions that follow. When you're sure you understand them, you're ready to install your base station.

Installing the base station

The following considerations are important to installation:

- From a radio perspective, the height of the receiving antenna is essential—the higher the antenna, the greater the communication range. In the case of the addIT devices, the antenna is built-in; therefore, the entire unit must be mounted as high as possible. A roof is an ideal location.
- Put the base station in the location most convenient to where you work, but keep in mind that, geographically, it is better to have it in the center of the area where the transmitters will be installed.
- Do not put the base station in places like cellars, near heat sources, or in damp locations.
- Make sure you have a telephone connection next to the PC for those times when you need technical support.

Installing the receiver

The receiver communicates over an RS485 interface. The receiver and the RTU look very much like, except that the receiver has only one connector, which links the receiver to the power supply. Figure 1 illustrates the addIT receiver.

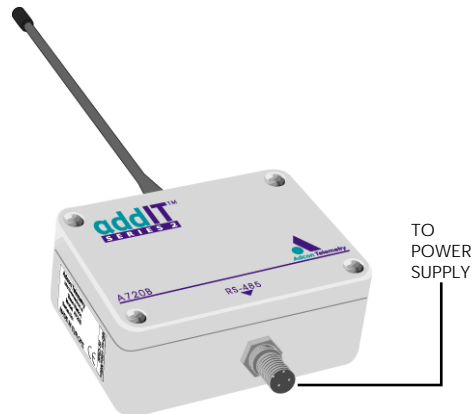

Figure 1. addIT Receiver

Follow these steps to install the receiver part of the base station.

1. Locate the best site for the receiver and mount a rod on the spot. The best site is usually on top of a roof or a mast.
2. Using the provided ring clamps, attach the receiver to the rod.
3. Attach the female connector on the cable to the male connector on the receiver by turning the plug's fastening screw.

Note: Standard cables are 30 m (approx. 99 ft) long. If you need a longer cable, you can purchase additional cables to extend the length up to 500 m (1640 ft).

4. Secure the cable to the rod with ties.
5. Bring the unattached end of the cable into the area where your computer is.

Installing the power supply

The A720PS power supply is the connection between the receiver and your computer. The power supply is universal and operates from 85 to 240 volts. Adcon supplies the serial cable and power cord. Figure 2 illustrates the addIT power supply.

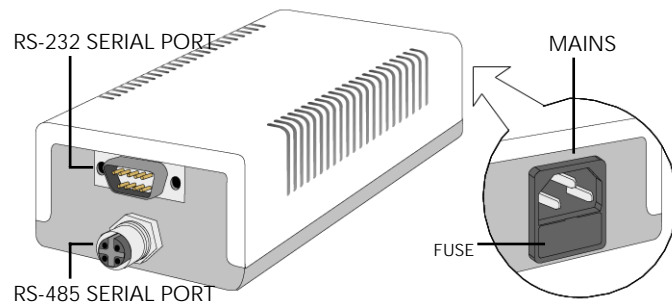

Figure 2. addIT Power Supply

Follow these steps to install the power supply:

1. Attach the cable from the receiver to the power supply.
2. Attach one end of the serial cable to the power supply and the other end to an available serial port on your computer.

Note: The serial cable ends are identical, so it doesn't matter which you use in each location.

3. Plug the appropriate ends of the power cord into the power supply and the power source (outlet).

Figure 3 shows the base station configuration.

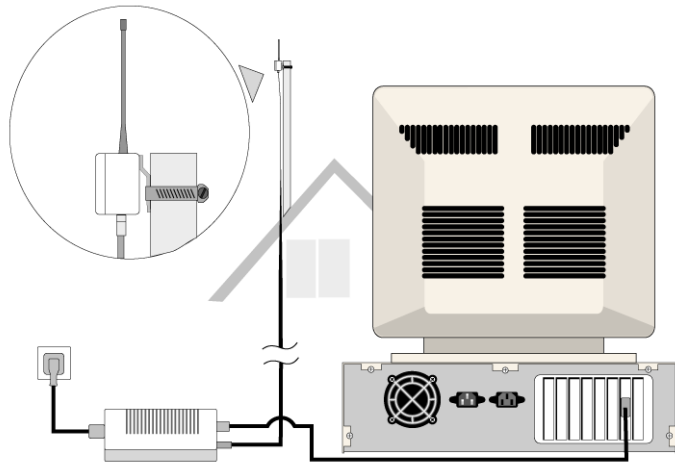

Figure 3. Base Station Configuration

Replacing the fuse

Should you need to replace the fuse, simply remove the old fuse from the power supply and insert a new 250 mA 250 V fuse.

Configuring the software

This manual details hardware installation only. Refer to the *addVANTAGE 4.1 Lite Reference Manual* for instructions about using addVANTAGE Lite software.

If you are experienced in technical software issues, you can also perform some configuration with the receiver by using a terminal window. See "Configuring the devices" on page 24 for these instructions.

Chapter 3. Using the RTU

Remember that the addIT A720/A723 remote telemetry units (RTUs) can be used either with the A730 system or as standalone systems with the A720B base station. The base station is discussed in “Using the Base Station” on page 9.

Opening the packages

You get several boxes when you purchase an addIT RTU. When you open them, you’ll see they contain:

- The A720/A723 RTU and ring clamp
- The solar panel, ring clamp, and connecting cable
- The aluminum rod and its cap
- A sensor and cable, one box for each sensor, with a fastening tie in each sensor box
- An LED tool

Make sure you’ve received all the equipment and read through the instructions that follow. When you’re sure you understand them, you’re ready to install your RTU.

Figure 4 shows an addIT RTU.

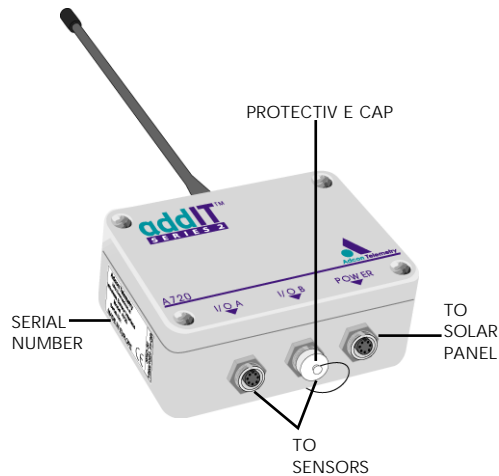

Figure 4. addIT RTU

Installing the RTU

Installing addIT RTUs in the field is a fairly simple process. You'll perform a connectivity check with an LED tool (addIT devices don't have a built-in LED like the A730MD stations do).

Note: The LED tool is a blind plug to be plugged in the POWER connector.

Follow these steps to install an addIT RTU in the field:

1. Review the installation area and choose the best site.
2. Perform a connectivity check using the LED tool:
 - a. Insert the LED tool in the POWER connector and wait up to 10 seconds. If the unit connects to at least one station (or a base station), it will light up the LED for about 4 seconds.
 - b. Keep observing the LED tool and, after another several seconds, the LED will blink one or more times (the number of blinks indicates the number of stations it has contacted).
3. Using a hammer, drive the supplied aluminum rod into the ground. How far you drive the rod into the ground depends

on your application. Put a plastic cap on top of the rod to protect it.

- Using a ring clamp, fasten the solar panel onto the aluminum rod. Ensure that the panel is facing south (north if you are located in the southern hemisphere) and out of the way of the addIT RTU.

Note: The solar panel can be mounted under or behind the addIT RTU, but be sure that the RTU does not shadow the panel.

- Fasten the addIT RTU to the top of the rod using another ring clamp. Adcon recommends that you perform another connectivity test, if you can, to check the positioning of the device.
- Attach the sensors to the I/O connectors and the solar panel to the POWER connector by turning the plugs' fastening screws clockwise until secure.



WARNING If you turn the fastening screws too tightly, you could damage the plugs.

- Secure the extra length of the sensor cables to the rod with ties.

Figure 5 shows what a typical RTU field installation looks like.

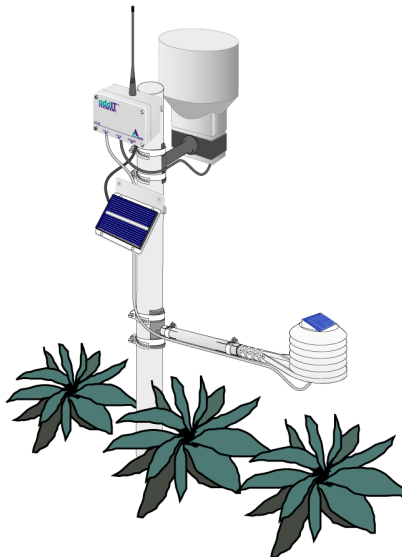

Figure 5. RTU in the Field

This completes the installation of your addIT RTU. If one of the I/O connectors is left unused, use the cap specially provided to protect it against moisture and dust. Be sure to make a note of the following information because you'll need it when you configure the device in the software:

- Serial number for each RTU
- Type of sensors connected to each RTU

More about the LED tool

The LED tool allows you to rapidly check the status of an addIT RTU. After you insert the LED tool into the POWER connector, the unit waits up to two seconds and then sends a broadcast frame. If a nearby listening station or receiver decodes the frame, it will answer back—this may take up to 10 seconds. When an answer is received, the LED tool lights up for about 4 seconds. After another few seconds, the LED lights up one or more times, depending on the number of stations/receivers that answered to its broadcast frame.

Note: addIT RTUs do not respond to a broadcast frame, only remote stations (A730MD) and base stations (A730SD or A720B).

In addition, the LED always blinks briefly at 0.5 second intervals to indicate that the unit is alive and the internal battery has enough energy to operate. If the blinking interval lengthens to 2 seconds, the battery has become undercharged (that is, under 5.6 volts but over 5.2 volts)—this is called the *misery* state. In this state, an addIT RTU reduces its activities to a minimum. The radio unit is switched off, the sensor sampling ceases, and no data is stored in the internal memory. Only the internal real-time clock is maintained and the power management functions are performed.

If the battery level drops below 5.2 volts, the system switches completely off, effectively decoupling itself from the battery in order to protect it. In this case the LED tool stays permanently off. An addIT RTU in such a situation will restart only after connecting it to an external power supply (even a solar panel under low light conditions).

Note: New addIT RTUs are delivered with their internal batteries unformatted, meaning they are completely discharged, and you should install them only on sunny days. The battery will

be fully charged after two consecutive sunny days, but you should get an LED light-up after several minutes of charging in the sunlight.

Configuring an addIT RTU in the addVANTAGE software

If you're using an addIT RTU with an A730 system, you can configure the RTU by following the steps described in the *addVANTAGE A730 Releases Notes for Version 3.35* or in the *addVANTAGE 3.40 User Manual*. If you're using the addIT RTU with addVANTAGE Lite, follow the steps described in the *addVANTAGE 4.1 Lite Reference Manual*.

Maintaining and servicing the RTU

The A720 and A723 units need virtually no maintenance. They are waterproof and designed to withstand harsh environmental conditions (-30 to +70 °C, or -22 to 158 °F), high RH values, water, and other noncorrosive liquids. They conform to the European protection class IP65. This applies also to the connectors, as long as they are mated. Don't let unmated connectors on either the addIT RTU or the sensors be exposed to the environment for extended periods of time.

The RTU battery

Note: The same type of battery is used in the A720/A723 and A720B devices, so the information in this section also applies to the A720B.

The internal battery supplies 6.2 volts and consists of a NiCd pack. The internal electronics manage the battery charging/discharging process, ensuring it a long life. This approach, coupled with a remarkably low average consumption (some mere 6 mW), allows an addIT RTU to operate at least one month on a fully charged battery, with the following conditions:

- The channel has moderate radio activity, with requests every 15 minutes.
- Total consumption of attached sensors is no more than 50 mA.
- The sensors are sampled once every 5 minutes and an averaged slot is stored in the internal memory every 15 minutes.

Table 1 shows the addIT devices' expected operation time on a fully charged battery with 50 mA total consumption for the sensors, as described above.

Table 1. addIT Device Operation Time

Radio Activity	Sensor Sampling (samples/15 min)	Average Consumption (µA)	Estimated Operation (days)
No	No sensors	450	92
Yes	No sensors	540	77
Yes	1	750	55
Yes	3 (default)	1080	38
Yes	5	1450	28
Yes	15	3100	13

Note: Radio activity refers to the fact that one base station and between one and three A730MD or addIT remote stations are active on the same operating frequency as the addIT remote station under test.

However, if for some reason (wear-out or accident) the battery loses its capacity (noted in the software with repeated "Battery low" messages), it must be replaced. Make sure, though, that the problem is really due to the battery and not to a defective or dirty solar panel.

Note: The solar panel works only with the A720/A723 devices. The A720B receiver's internal battery is charged by the power supply.

Adcon highly recommends that you check the solar panels' state and clean them often. The rain droplets can splash thin layers of soil on the panels, greatly reducing their power output. The surrounding vegetation can also lower the panels' efficiency.

Changing the battery

Note: The same type of battery is used in the A720/A723 and A720B devices, so the information in this section also applies to the A720B.

If you have verified that the battery needs to be replaced, follow these steps to do so:

1. Open the lid by unscrewing the four screws in the corner of the addIT RTU.
2. Gently remove the lid (the battery is fixed on the lid and is connected to the electronics board by means of a connector).
3. Remove the battery's plug from the PCB connector.
4. Remove the battery pack from the lid (it is taped to the lid) and replace it with a new one (obtainable from Adcon).
5. Insert the battery plug into the PCB connector.
6. Mount the lid back, taking care that the rubber gasket sealing the box is not out of place.



WARNING Be sure to mount the rubber gasket properly, so that the unit's IP65 environmental protection is not affected.

7. Screw the four screws back in, applying a moderate force.

Chapter 4. Performing Advanced Functions

With the appropriate knowledge, you can configure the addIT devices in the field by using a hyperterminal window. To configure the RTU, you will need a special serial cable adapter (not supplied, available from Adcon).



CAUTION Do not try to configure your addIT devices if you are not sure what to do—the unit may not communicate with the remote measuring station or function with the addVANTAGE software.



WARNING Tampering with parameters for the addIT devices may void your warranty or damage the device. In general, the commands described in this chapter are intended for technical support staff and users with a great deal of highly technical hardware and software experience.

In the system architecture, the base station and RTU are both considered to be nodes. The base station is called the master node, or *master*, while the RTU is called the slave node, or *slave*.

Device series

Currently, two A720 device versions are in use: Series 1 and Series 2. In addition, since the beginning of 2001, Adcon introduced also the Series 3 model (A723). You can determine which series a device is in any of these ways:

- The `VER` command (see pages 29 and 52). When the device is connected, you can type this command to the series. With a Series 1 device, the command returns `VER 1.0` or higher, while with a Series 2 device, the return is `VER 2.0` or higher. This is the most reliable method of determining which series you have. To differentiate between A720 and A723 devices, type the command `TYPE`, and an A723 will return the string `TYPE A723`.
- The logo on the front of the device. Series 2 devices include such wording on the logo. However, if you returned a Series 1 device for repair, it is possible that it was replaced with a Series 2 motherboard. In such a case, you would have a Series 2 device in Series 1 housing. Series 3 devices (A723) are marked as such.

Understanding connectors

The addIT devices have cable attachments called connectors. The connector type determines how the device communicates with the sensors or the computer.

The receiver connector

The addIT A720B receiver has one 4-pin connector. Figure 6 illustrates this connector and Table 2 details the connections.

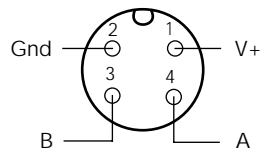

Figure 6. addIT Receiver Connector (Top View)

Table 2. addIT Receiver Pin Functions

1	Bus Power (V+)
2	Bus Power (GND)
3	Bus Communications (B)
4	Bus Communications (A)

The RTU connectors

The addIT RTU uses standard 7-pin sensor I/O A and I/O B connectors (model Binder 702 and 712 series or equivalent) that are identical. Each connector contains three analog inputs (0 to 2.5 volt) and two digital input/outputs, one of which you can use as a pulse counter (for example, a rain gauge). Figure 7 illustrates the individual pins of an I/O connector.

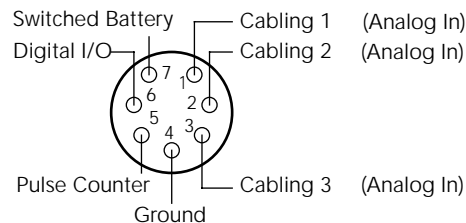
**Figure 7. Pins on an I/O Connector (Top View)**

If you have a special passive extender cable, you can use it to plug more than one sensor to one connector.

CAUTION To avoid cabling conflicts, first verify in the addVANTAGE software that the sensor combination in the configuration you want is allowed. If there are no conflicts, you can physically attach the sensors to the addIT RTU.

addIT RTUs can also be used to control actuators and to switch on or off pumps, valves, or other similar devices (for example, using the Macro extension). The same principles for macro commands using an A730MD remote measuring devices apply to addIT RTUs, with the sole difference that instead of three, only the first two outputs are available.

The RTU also has a POWER connector. Figure 8 illustrates the connections available at the POWER connector.

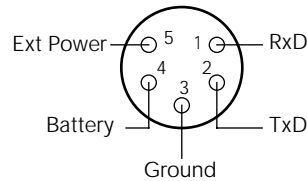

Figure 8. addIT RTU POWER Connector (Top View)



WARNING The RxD and TxD connections are not RS-232 compatible.

This configuration allows the use of external power supplies or extra batteries (contact Adcon for further details).

Configuring the devices

You can use a Windows Hyperterminal window to connect to either addIT device. After you have installed the system, follow these steps to configure the device:

Note: To configure the A720B receiver, use the serial cable that comes with the system. To configure the A720 or A723 RTU, you must have the special adapter cable (available from Adcon) and plug it into the POWER connector.

1. Open a Hyperterminal window.
2. Select the appropriate serial port and click **OK**.
3. Configure your terminal as follows:
 - 19200 baud
 - 1 stop bit
 - 8 data bits
 - No parity
 - No flow control
 - Send LF after CR
4. Select **OK** to open the terminal window.
5. Press **Enter** to generate a response in the window.

Serial communication protocol

This protocol is based on a master sending commands and a node answering; the whole communication is conducted in plain ASCII, as strings. When exchanging numbers, they are represented in decimal format. All commands are terminated with a CR/LF combination. All responses (answers) are terminated with the # character.

General format of a command

The commands have the following format:

ID Command Param1 Param2 ... ParamN

- *ID* is the destination device. If you include an ID as part of a command, the node checks whether *ID=ownID*. If it does, the node executes the command on itself. If the ID is not the node's ID, the node executes the command on a remote device, if such an ID exists. If the ID is missing, this implies that the command is addressed locally.

Note: Not all the commands can be relayed remotely.

- *Command* is the command proper, which can be composed of a variable string of characters (for example, *SLOT*). Each node can implement a set of commands depending on the functionality of the node itself. However, as a minimum requirement, a node recognizes the *CMDS* command, which returns a list with the commands recognized by the node.
- *Param1 Param2 ... ParamN* represent the parameters, which are command dependent. If you type no parameters when you issue a command, it is the equivalent of querying for information (the **GET** version of a command). If you type parameters, you are issuing the **SET** version of a command and are setting the command to the parameters you typed.

General format of an answer

The answers have the following format:

ID Command Result1 Result2 ... ResultN ErrResult #

- *ID* is the answering device. If a command was further routed, it is the ID of the end device. The answer must always contain the ID on return.

- *Command* is the string representing the original command. It is supplied so that a master can distinguish between the answers it is waiting for, and out-of-band notifications (which may come, for example, over the radio port of a node). As with the ID, the command name must be always supplied.
- *Result1 Result2 ... ResultN* are the result values returned by the remote node. If the *ErrResult* is not zero, all other possible characters and/or strings until the end of the line may be ignored.
- *ErrResult* shows whether the command was successfully executed. If this value is 0, the command was successfully executed. If this value is other than 0, the command failed. The number may further indicate the error type. (See also “Returned errors list” on page 54.)

The answer string may contain any number of spaces or CR/LF characters between its components; however, after the terminator (#) no other characters are allowed.

Using terminal commands

Following is a list of available commands and an explanation of their use.

Note that for Series 1 devices, you preface a change in a setting with **SET**, while with Series 2 devices you do not.

Note: You can type uppercase or lowercase characters because the commands are not case sensitive.

Series 1 devices

The SET series of commands

COMMAND	SET OWNID <i>nnnn</i>
DESCRIPTION	Sets the identification of the unit.
PARAMETERS	<i>nnnn</i> is the ID number of the unit.
RETURNS	Nothing.
REMARKS	The ID number must be identical to the one written on the unit's label.

EXAMPLE	SET OWNID 2003
COMMAND	SET PMP <i>bl bh</i>
DESCRIPTION	Sets the power management parameters.
PARAMETERS	<i>bl</i> is the lower battery level (the threshold where the charging of the battery is switched on) and <i>bh</i> is the higher battery level (the charging is switched off).
RETURNS	Nothing.
REMARKS	Both <i>bl</i> and <i>bh</i> are expressed in volts x 10 (for example, 72 actually means 7.2 V). Default values (factory programmed) are 65 and 72, meaning 6.5 and 7.2 volts respectively.
EXAMPLE	To change the switch-on threshold to 6.3 and the switch-off threshold to 7.0 volts: SET PMP 63 70
COMMAND	SET SLOT <i>storage samples</i>
DESCRIPTION	Configures the input sampling and storing intervals.
PARAMETERS	<i>storage</i> represents the time (in seconds) elapsed between two slots stored in the internal memory, while <i>samples</i> represents the numbers of samples used to build the average that will be stored.
RETURNS	Nothing.
REMARKS	The default <i>storage</i> is 900 (15 minutes) and <i>samples</i> is 3 (3 samples per quarter of an hour).
EXAMPLE	To sample the inputs (sensors) every minute and build an hourly average: SET SLOT 3600 60 To sample the inputs once per hour and store the values as they are: SET SLOT 3600 1



WARNING Changing the above parameters may adversely affect the ability of the device to operate for extended periods under low solar radiation conditions when used with addVANTAGE 3.x. Even if you change them, addVANTAGE will not display the charts accordingly: the current addVANTAGE version supports only 15-minute data slots. Changing the *storage* parameter to lower than 60 or higher than 1500 will lead to a total data loss in addVANTAGE 3.x. This warning does not apply to usage with addVANTAGE 4.x Lite software.

COMMAND**SET FREQ** *freq step***DESCRIPTION**

Sets the unit's operating frequency.

PARAMETERS*freq* is the frequency and *step* is the channel spacing (both expressed in Herz).**RETURNS**

Nothing.

REMARKS

Convert values to Herz before issuing the command.

EXAMPLE

To change the frequency to 467.1125 MHz with a channel spacing of 12.5 kHz:

SET FREQ 467112500 12500

CAUTION Do not change the frequency of your device without reason: apart from the fact it may not communicate in the network anymore, you may also violate the applicable radiocommunications laws in your country. Depending on the destination country, some models may also return an error message.

COMMAND**SET RSSI** *value***DESCRIPTION**

Sets the Relative Signal Strength Indicator threshold.

PARAMETERS*value* is the RSSI setting.**RETURNS**

Nothing.

REMARKS

The factory default is set to 58 units. The RSSI threshold is used to detect if any radio activity is on the channel. The value set must be approximately 30% higher than the actual measured value when no signal is present on the channel. To measure the actual value, use the command `RSSI` (see "Querying the actual configuration parameters").

EXAMPLE

To set the RSSI threshold to 58:

```
SET RSSI 58
```

Querying the actual configuration parameters

You can query an addIT to find out its actual configuration parameters (**GET** the parameter). Typing **OWNID**, for instance returns the actual ID an addIT answers to (it should be the same as the one on its label). In addition to **OWNID**, **PMP**, **SLOT**, **FREQ**, and **RSSI**, the command **VER** returns the current software version of the device.

The **RSSI** command returns two values: the actual measured value of the RSSI and the value set as threshold. As noted elsewhere, the threshold must be approximately 30% higher than the actual measured value. The actual RSSI is unstable due to the channel's random noise, receiver's internal noise, and/or to transmissions just taking place. If the actual RSSI value is consistently higher than the programmed value, something must be wrong, or the channel is very noisy (however, before readjusting the RSSI threshold, check this with a handheld radio receiver or a scanner).

Other commands available in terminal mode are:

- **DUMP *addr***—displays 256 bytes of the internal EEPROM memory, starting with the address *addr* (specified as hex values). Valid addresses for the model A720 are B600 to B9FF. The last 16 slots of data (for 15-minute slots, that makes 4 hours of data) are stored at B900 to B9FF. The remainder are used for internal configuration parameters or reserved for future use.
- **RX**—switches the device to receive mode until a key is pressed. This command is used for trimming or checking purposes.
- **XMIT *param***—switches the device to transmit mode until a key is pressed. This command is used for trimming or checking purposes. *param* may be any of the following:
 - 0—a 2 kHz tone will be modulated on the transmitted carrier
 - 1—a 1 kHz tone will be modulated on the transmitted carrier
 - T—a mixture of 1 and 2 kHz test tones
 - Not given—an unmodulated carrier will be transmitted

- B – sends a broadcast frame and displays all the answers.

Series 2 and 3 devices

*Note: With Series 2 and 3 devices, typing the command by itself is a **GET** command, while typing the command with parameters or variables is a **SET** command.*

COMMAND	CMDS
APPLIES TO	A720, A720B, A723
DESCRIPTION	Returns a list of supported commands.
PARAMETERS	None.
REMARKS	GET only.
RETURNS	A list of strings separated by spaces.
REMOTE	No.
EXAMPLE	<pre> CMDS 193 CMDS CMDS ID PMP RSSI TIME FREQ DEV DEL REPL SLOT DATA INFO RX TX ERA 0 # </pre>

COMMAND	TIME
APPLIES TO	A720B, A723
DESCRIPTION	Sets/returns the real time clock.
PARAMETERS	The actual time, or none in the GET version.
RETURNS	The actual time as dd/mm/yyyy hh:mm:ss.
REMARKS	GET/SET.
REMOTE	No.
EXAMPLES	<pre> TIME 12/12/1998 22:10:10 193 TIME 0 # TIME 193 TIME 12/12/1998 22:10:10 0 # </pre>

COMMAND	FREQ
	 CAUTION Do not change the frequency of your device without reason. Apart from the fact that it may not communicate with the network anymore, you may also violate the applicable radio-communications laws in your country. Depending on the destination country, some models may also return an error message when trying to use this command.
APPLIES TO	A720, A720B, A723
DESCRIPTION	Sets/returns the operating frequency.
PARAMETERS	The operating frequency and step (Hz), or none in the GET version.
RETURNS	The actual frequency and step, in Hz.
REMARKS	GET/SET.
REMOTE	Yes, SET only.
EXAMPLE	<pre>FREQ 433925000 25000 193 FREQ 0 #</pre> <pre>FREQ 193 FREQ 433925000 25000 0 #</pre>
COMMAND	RSSI
APPLIES TO	A720, A720B, A723
DESCRIPTION	Sets/returns the Relative Signal Strength Indicator threshold at which an RF receiver must wake up.
PARAMETERS	The threshold value. For the A720 family, it can take values from 0 to 255; it is typically factory set to 58. For the A723, it typically factory set to 42.
RETURNS	The instant RSSI value and the programmed threshold.
REMARKS	The factory default is set to 58 units. The RSSI threshold is used to detect if any radio activity is on the channel. The value set must be approximately 30% higher than the actual measured value when no signal is present on the channel. To measure the actual value, use the command RSSI with no variables or parameters.

REMOTE	No.
EXAMPLE	<pre> RSSI 58 193 RSSI 0 # RSSI 193 RSSI 44 58 0 # </pre>
COMMAND	ID
APPLIES TO	A720, A720B, A723
DESCRIPTION	Sets/returns the node's ID.
PARAMETERS	The node ID.
RETURNS	The node ID.
REMARKS	GET/SET.
REMOTE	Yes, SET only.
EXAMPLE	<pre> ID 4557 193 ID 0 # ID 4557 ID 4557 0 # 6556 ID 7557 6556 ID 0 # </pre>

Note: The last example shows a case where a remote node was instructed to change its own ID from 6556 to 7557. Even if it changed its ID, it answers with the old ID in order to correctly finish the transaction.

COMMAND

SLOT

CAUTION Changing these parameters may adversely affect the ability of the device to operate for extended periods under low solar radiation conditions.

APPLIES TO	A720, A720B, A723
DESCRIPTION	Sets/returns the input storing and sampling intervals.
PARAMETERS	<i>storage</i> represents the time (in seconds) elapsed between two slots stored in the internal memory, while <i>samples</i> represents the numbers of samples used to build the average that will be stored.
RETURNS	The interval and rate.
REMARKS	The default <i>storage</i> is 900 (15 minutes) and <i>samples</i> is 3 (3 samples per quarter of an hour).
REMOTE	Yes, SET only.
EXAMPLE	<pre> SLOT 900 3 193 SLOT 0 # SLOT 193 SLOT 900 3 0 # </pre> <p><i>Note: The A720B base station needs only the rate. For consistency, however, it accepts both parameters and discards the one it doesn't need.</i></p>
COMMAND	PMP
APPLIES TO	A720, A720B, A723
DESCRIPTION	Sets/returns the node's Power Management Parameters (switches on/off the battery charge).
PARAMETERS	The lower (switch on) and the higher limit (switch off), both in volts x 10. Standard Values are 65 (for 6.5 Volts) for switch on and 72 (for 7.2 Volts) for switch off.
RETURNS	The lower (switch off) and the higher limit (switch on), both in volts x 10.
REMARKS	GET/SET.
REMOTE	Yes, SET only.
EXAMPLE	<pre> PMP 65 72 193 PMP 0 # </pre>

```
PMP
193 PMP 65 72 0
#
```

COMMAND	CM
APPLIES TO	A723
DESCRIPTION	Sets/returns the A720 compatibility mode.
PARAMETERS	0 means A723 native mode while 1 switches the unit in A720 compatible mode. In this mode, although the device presents itself as an A723 (when issuing the <code>INFO</code> command), it will return the frame type 38 when asked for <code>DATA</code> (see also “ <code>DATA</code> ” on page 36). This mode is useful when the A723 device is used with the A720B base station or with an addVANTAGE 3.35 software (addVANTAGE 3.4 and later recognizes an A723 in its native mode).

There is also an additional compatibility mode (`CM 2`) that forces the A723 to respond with an A720 compatible answer to the `INFO` command. This mode is not recommended for normal use.

By default the A723 devices are delivered in native mode (`CM` is 0).

RETURNS The current mode.

REMARKS **GET/SET.**

REMOTE No.

```
EXAMPLE CM 1
193 cm 0
#

CM
193 CM 1 0
#
```

COMMAND	SST
APPLIES TO	A723
DESCRIPTION	Sets/returns Sensor Sampling Time. This is the delay allowed for the sensors to settle after applying them power and until they are sampled.
PARAMETERS	The settling time in seconds.

RETURNS	The actual sensor settling time (default is 2 seconds).
REMARKS	GET/SET.
REMOTE	No.
EXAMPLE	<pre> SST 2 193 sst 0 # SST 193 sst 2 0 # </pre>
COMMAND	DEV
APPLIES TO	A720B
DESCRIPTION	Inserts/reads the devices in the local devices list.
PARAMETER	The device to be inserted (in the SET version).
RETURNS	The devices list (in the GET version). The GET version displays additional information about the devices, such as the last slot in the local memory and a flag showing whether a notification is pending (for more details about notifications, see “Notifications” on page 53).
REMARKS	GET/SET.
REMOTE	No.
EXAMPLE	<pre> DEV 5667 193 DEV 0 # DEV 193 DEV 5667 22/1/1999 19:39:40 0 5668 21/1/1999 15:26:54 0 0 # </pre>
COMMAND	REPL
APPLIES TO	A720B
DESCRIPTION	Replaces a device ID by another device ID in the local devices list.

Performing Advanced Functions

PARAMETERS The old ID and the new ID.

RETURNS Nothing.

REMARKS **SET** only.

REMOTE No.

EXAMPLE **REPL 5667 5666**
193 REPL 0
#

REPL
193 REPL 5
#

*Note: The second example shows a **REPL** command without parameter: error 5 is returned (missing or false parameter).*

COMMAND **DEL**

APPLIES TO A720B

DESCRIPTION Deletes a device from the local devices list.

PARAMETERS The ID of the device to be deleted.

RETURNS Nothing.

REMARKS **SET** only.

REMOTE No.

EXAMPLE **DEL 5666**
193 DEL 0
#

DEL
193 DEL 5
#

*Note: The second example shows a **DEL** command without parameter: error 5 is returned (missing or false parameter).*

COMMAND **DATA**

APPLIES TO A720, A720B, A723

DESCRIPTION	Returns data stored for a certain device.
PARAMETER	The ID of the device for which the data is requested and the date/time (in the standard format) the data was stored. If missing, then it refers to the data of the local device.
RETURNS	A data block.
REMARKS	GET only. If you don't include the date/time parameter, the latest data is returned. If you include the date/time parameter, the date and time closest to, but later than, the given date/time is returned.
REMOTE	Yes, for a GET on the A720B and A723, but only one frame at a time. If you are using a terminal window for the A720, you cannot issue the <code>DATA</code> command remotely. If you are using a terminal window for the A720B, you can issue a <code>DATA</code> command for an A720 or A723 RTU, but you cannot issue the command for the A720B receiver. In other words, the base station can issue a remote command for an RTU, but it cannot issue such a command for itself. The A720 RTU can issue the command only for itself, and only locally, while the A723 RTU can also issue remote data commands.

EXAMPLE

```
DATA 5666 12/12/1998 12:12:12
193 DATA b1 b2 b3 ... bn 0
#
```

The data block returned will typically contain a number of data frames (telegrams). The structure of a block is as follows:

```
dd mm yyyy hh mm ss si ft d1 d2 ... dn dd mm yyyy
... dn cs
```

where:

- *dd mm yyyy* is the date
- *hh mm ss* is the time
- *si* is the size of the frame
- *ft* is the frame type (38 for addIT devices)
- *d1 d2 ... dn* are the data values (the frame content)
- *cs* is a 16-bit checksum obtained by summing the bytes and discarding the carries over `0xFFFF`

The A720 devices respond with a type 38 data frame, while the A723 may respond with type 38 or type 39, depending on the `CM` flag (see also “`CM`” on page 34). The most important difference

between the frames 38 and 39 is that the later accommodates for 12 bit analog values for the sensor sampling inputs and 16 bit counters for the pulse counter inputs. In addition, the correspondence between input analog and digital ports and their position in the frame differs.

The composition of the data block of a frame type 38 (the bytes marked as d1, d2... dn) is depicted in Figure 9, a type 39 frame in Figure 10 while the digibyte is depicted in Figure 11 and Figure 12.

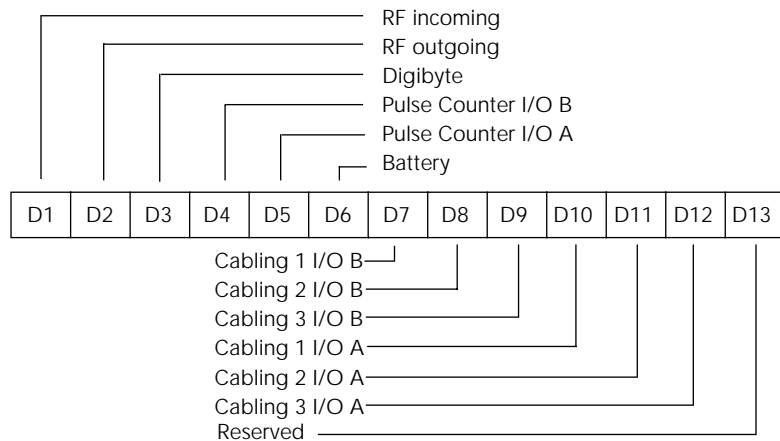

Figure 9. Frame 38 description

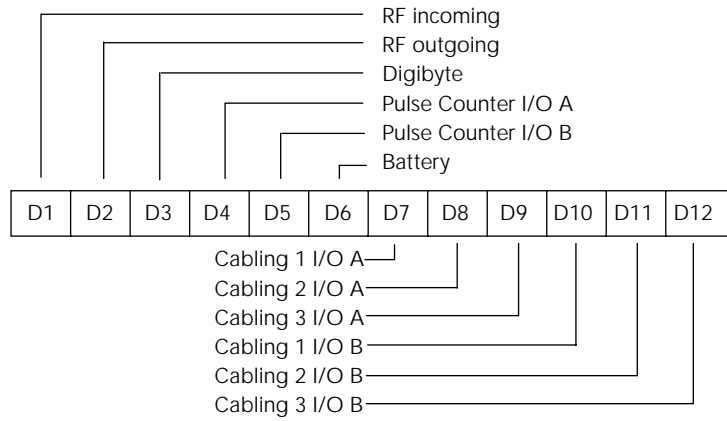
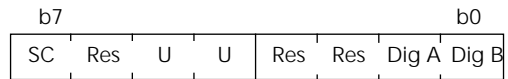

Figure 10. Frame 39 description



SC — Battery charge (0-off, 1-on) Dig A — Digital I/O A
 Res — Reserved Dig B — Digital I/O B
 U — Undefined

Figure 11. The Digibyte for an A720 device



SC — Battery charge (0-off, 1-on) Dig n — Digital I/O A...X
 Note: Only Dig A and Dig B are wired externally

Figure 12. The Digibyte for an A723 device

The remote version is limited to a single frame. An example of such a command is given below:

```
6367 DATA 6367 30/4/1999 14:50:00
6367 DATA
```

```

30 4 1999 14 54 55 14 38 255 255 77 0 0 89 156 126
20 0 0 0 0
3185 0
#

```

Notice that if you need to get data that is not the last (newest) slot remotely from a device, the ID must be supplied twice. If you need to get the last slot stored, you can ignore the ID and the date/time parameters:

```

8300 DATA
8300 DATA
13 5 1999 19 26 36 14 38 255 255 79 0 0 87 148 149
15 0 0 0 0
3138 0

```

COMMAND	IMME
APPLIES TO	A723
DESCRIPTION	Returns immediate data.
PARAMETERS	None.
RETURNS	A formatted string representing the data sampled on the input ports.
REMARKS	GET only. The answer to this command is delayed with the <i>SST</i> time (see also “ <i>SST</i> ” on page 34). The values represent the normal <i>DATA</i> frame values but formatted for easy human identification.

REMOTE No.

EXAMPLE

```

IMME
16816 IMME 30 8 2001 16 15 06 13 39 0 0 127
      0 0 95
      0 0 0 0 0 0
2350 0
#

```

COMMAND	ROUTE
APPLIES TO	A723
DESCRIPTION	Updates a routing table that will be used for remote commands (e.g. <i>DATA</i> , <i>INFO</i> , etc.).

PARAMETERS	The destination node and the intermediate nodes, on the order starting from the issuing node to the target (remote) node.
RETURNS	The actual routing table (in GET mode).
REMARKS	GET/SET .
REMOTE	No.
EXAMPLE	<pre> ROUTE 2419 10836 16816 ROUTE 0 # ROUTE 16816 ROUTE 2419 10836 0 # </pre>
COMMAND	FDEV
APPLIES TO	A720, A720B, A723
DESCRIPTION	Formats the internal memory (destroys all the data).
PARAMETERS	None.
RETURNS	Nothing.
REMARKS	SET only.
REMOTE	Yes, SET only.
EXAMPLE	<pre> FDEV 193 FDEV 0 # </pre> <p><i>Note: Depending on the device's memory size, this command may take several seconds to complete.</i></p>
COMMAND	INFO
APPLIES TO	A720, A720B, A723
DESCRIPTION	Returns various status information.
PARAMETERS	None.
RETURNS	A list of a device's internal variables:

```
ID INFO rf_in rf_out date time ver clk stack cop
batt temp days_uptime min:sec_uptime rssi pmp_low
pmp_high type slot samples po err_level
#
```

The formats for the above parameters are as follows:

- *rf_in* and *rf_out* as a decimal
- *date* as dd/mm/yyyy
- *time* as hh:mm:ss
- *ver* as x.x
- *clk*, *stack*, and *cop* as decimal; they represent internal housekeeping parameters and are implementation dependent (the A720 uses *cop* to number watchdog occurrences, but *clk* and *stack* are currently undefined for the A720; for the A723 *clk* returns the SST – Sensor Sampling Time value, default 2)
- *batt* as battery level using the standard voltage conversion equation (0 is 0 volts, 255 is 20 volts)
- *temp* as internal temperature in the A720 housing, which is device dependent. The precision of the sensing element is very low ($\pm 4^{\circ}\text{C}$), but it is sufficient for battery power management (charge/discharge). To compute the actual value (in $^{\circ}\text{C}$), the following equation must be used:

$$Temp = internalTemp \cdot \frac{1087}{255} - 275$$

- *days_uptime* in days; together with *min:sec_uptime*, it represents the amount of time the device is up without a reset or watchdog
- *min:sec_uptime* in minutes:seconds format
- *rssi* as decimal; it is the programmed value with the **RSSI** command
- *pmp_low* and *pmp_high* are the programmed values with the PMP command
- *type* is used to represent the device type; following types are assigned currently:
 - 0 for A730MD
 - 1 for A720
 - 2 for A730SD
 - 3 for A720B

	<ul style="list-style-type: none"> — 4 for A733 — 5 for A723 — 6 for A440 • <i>slot</i> and <i>samples</i> are the actual values programmed by means of the <code>SLOT</code> command • <i>po</i> (A723 only) is the relative output power • <i>err_level</i> is the error value; 0 means no error
REMARKS	GET only.
REMOTE	Yes, GET only. The A720B and A723 can issue the command both remotely and locally, while the A720 can issue the command only locally.
EXAMPLE	<p>INFO</p> <pre>193 INFO 255 0 18/4/1999 21:5:11 1.3 0 0 0 91 72 40 1:46 58 65 72 3 900 0 0 #</pre>
COMMAND	ANLG
APPLIES TO	A723
DESCRIPTION	Sets/returns various parameters of the analog subsystem (e. g. the sampling/averaging method used for individual data acquisition channels).
PARAMETERS	A control byte specifying the command and the analog input channel number the command is acting on:

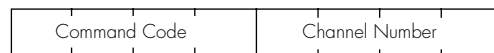

Figure 13. The ANLG Control Byte Layout.

Some commands may also require one or two additional 16 bit parameters representing threshold values.

- The **Channel Number** selects the analog channel that will be affected by the command. For the A723 device, only 0000 to 0101 are accepted (only 6 analog channels are available).

- The **Command Code** specifies the operation that will be applied to the selected channel. They are described in the table below:

Table 3. Command Code Definitions for the Analog Command

Code	Description	Parameters	Returns
0000	RSM – Read Sampling Method. This command reads the current programmed sampling method for all analog input channels.	None.	The current sampling methods and the result (OK or ERROR). See also the table that follows.
0001	SSMMI – Set Sampling Method to Minimum. The specified analog channel will be instructed to store the lowest sampled value.	The channel number.	Result (OK or ERROR).
0010	SSMMA – Set Sampling Method to Maximum. The specified analog channel will be instructed to store the highest sampled value.	The channel number.	Result (OK or ERROR).
0011	SSMS – Set Sampling Method to Sum. The specified analog channel will be instructed to store the sum of all sampled values.	The channel number.	Result (OK or ERROR).
0100	SSMAA – Set Sampling Method to Arithmetic Average. The specified analog channel will be instructed to store the arithmetic average of all sampled values.	The channel number.	Result (OK or ERROR).
0101	SSMCA – Set Sampling Method to Circular Average. The specified analog channel will be instructed to store the circular average of all sampled values.	The channel number.	Result (OK or ERROR).
0110	SSMF – Set Sampling Method to First. Only the first sampled value will be stored in each slot.	The channel number.	Result (OK or ERROR).
0111	SSML – Set Sampling Method to Last. Only the last sampled value will be stored in each slot.	The channel number.	Result (OK or ERROR).
1000	RNS – Read Notification Status ^a . If no notification was pending, this command should return an error. If one was pending, the notification is cleared.	The channel number.	Returns the time when the threshold was reached (in standard time format) and the result (OK or ERROR).
1001	RPNNER – Read the Pending Notifications and the Notification Enable Register. This command returns the 16-bit Pending Notifications and the Notification Enable Registers; the Port Number has no significance for this command.	None.	Two 16-bit integers (first the PN and then the NE register) and the result (OK or ERROR).
1010	DAN – Disable Any Notification.	The channel number.	Result (OK or ERROR).
1011	RNTTL – Read Notification Type and Thresholds/Limits.	The channel number.	One 8-bit char (Notification Type), two 16-bit integers (first the lower limit and then the higher limit) and the result (OK or ERROR). If only a threshold was set, then the second 16-bit integer is irrelevant.

Table 3. Command Code Definitions for the Analog Command

Code	Description	Parameters	Returns
1100	ENOPTR – Enable Notify On Positive Threshold Reached.	The channel number and the threshold (16 bit value).	Result (OK or ERROR).
1101	ENONTR – Enable Notify On Negative Threshold Reached.	The channel number and the threshold (16 bit value).	Result (OK or ERROR).
1110	ENOL – Enable Notify if Out of Limits.	The channel number and the limit values (16 bit value), first the lower and then the higher limit.	Result (OK or ERROR).
1111	ENIL – Enable Notify if Inside the Limits.	The channel number and the limit values (16 bit value), first the lower and then the higher limit.	Result (OK or ERROR).

a. See also “Notifications” on page 53.

Sampling methods are defined by three bits, as follows:

Table 4. Sampling Method Definitions

Sampling method	Binary value	Description
Reserved	000	Not defined.
Minimum	001	If more than one sample per slot is performed, the lowest value will be stored.
Maximum	010	If more than one sample per slot is performed, the highest value will be stored.
Sum	011	The sum of all samples for a certain slot will be stored.
Average (arithmetic)	100	If more than one sample per slot is performed, the arithmetic average of all samples will be stored.
Average (circular)	101	If more than one sample per slot is performed, the average computed on a circle will be stored (i.e. on a 0 to 359 deg. circle, overflow occurs at the 359 deg value).
First sample	110	If more than one sample per slot is performed, the first value will be stored. All other samples are discarded.
Last sample	111	If more than one sample per slot is performed, the last value will be stored. All other samples are discarded.

Following notification types can be returned when issuing the RNTTL command:

Value	Notification Type
00	Notify On Positive Threshold.
01	Notify On Negative Threshold.
10	Notify if Out of Limits.
11	Notify if Inside the Limits.

RETURNS The return result depends on the control byte (see table). However, whatever the return result is, it includes the control byte.

REMARKS The general behavior is that an `ANLG` command issued on a certain input channel will override any previous `ANLG` commands affecting that channel.

REMOTE The A723 device cannot issue `ANLG` commands remotely, but can execute them.

EXAMPLE For **RSM**

```
ANLG 0
9999 ANLG 0 5 5 5 5 5 5 5 4 4 5 5 0
#
```

For **SSMAA** (on channel 4)

```
ANLG 68
9999 ANLG 68 0
#
```

For **DAN** (on channel 0)

```
ANLG 160
9999 ANLG 160 0
#
```

For **RNTTL** (on channel 2)

```
ANLG 178
9999 ANLG 178 340 3900 0
#
```

For **ENOPTR** (on channel 10)

```
ANLG 202 1000
9999 ANLG 202 0
#
```

COMMAND

PORT

APPLIES TO	A720B and A723, but see also the comments in “Remote” on page 49.
DESCRIPTION	A complex command acting upon the I/O ports of a device.
PARAMETERS	A control byte specifying the command, the bit of the port the command is acting on, and two 16-bit parameters, depending on the control byte; for some commands, one or both of them may be missing. However, if they are needed for a certain command but not given, null values are implied.

The control byte's significance is shown in Figure 14.

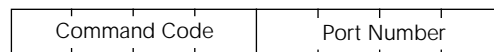

Figure 14. Control Byte Layout

- The **Port Number** selects a the port that will be affected by the command. For the A720/A723, only 0000 and 0001 are accepted.
- The **Command Code** specifies the operation that will be applied to the selected port.

Table 5 shows the command codes definitions.

Table 5. Command Code Definitions

Code	Description	Parameters	Returns
0000	RDP – Read Data Port. This command reads the whole 16-bit port and returns its value; the Port Number has no significance for this command.	None	A 16-bit integer and the result (OK or ERROR).
0001	RDDR – Read Data Direction Register. This command reads the whole 16-bit Data Direction Register and returns its value; the Port Number has no significance for this command.	None	A 16-bit integer and the result (OK or ERROR).
0010	CAI – Configure the port specified by Port Number as input (acts upon the Data Direction Register).	The port number.	Result (OK or ERROR).
0011	CAO – Configure the port specified by Port Number as output (acts upon the Data Direction Register).	The port number.	Result (OK or ERROR).

Table 5. Command Code Definitions (Continued)

Code	Description	Parameters	Returns
0100	RBV – Read the specified bit.	The port number.	Bit value and the result (OK or ERROR).
0101	RNS – Read the notification ^a status. If no notification was pending, this command should return an error. If one was pending, the notification is cleared.	The port number.	Returns the time of the last port change in standard time format and the result (OK or ERROR).
0110	DNOPC – Disable Notify On Port Change.	The port number.	Result (OK or ERROR).
0111	ENOPC – Enable Notify On Port Change.	The port number.	Result (OK or ERROR).
1000	RPNNER – Read the Pending Notifications and the Notification Enable Register. This command returns the 16-bit Pending Notifications and the Notification Enable Registers; the Port Number has no significance for this command.	None.	Two 16-bit integers (first the PN and then the NE register) and the result (OK or ERROR).
1001	CB – Clear the specified bit.	The port number.	Result (OK or ERROR).
1010	SB – Set the specified bit.	The port number.	Result (OK or ERROR).
1011	XB – Exclusive Or the specified bit.	The port number.	Result (OK or ERROR).
1100	MFR – Monostable function, start with the specified bit in OFF state (reset).	The port number, the OFF and the ON times (in seconds), both as 16-bit integers.	Result (OK or ERROR)
1101	MFS – Monostable function, start with the specified bit in ON state (set).	The port number, the OFF and the ON times (in seconds), both as 16-bit integers.	Result (OK or ERROR).
1110	MVFR – Multivibrator function, start with the specified bit in OFF state (reset).	The port number, the OFF and the ON times (in seconds), both as 16-bit integers.	Result (OK or ERROR).
1111	MVFS – Multivibrator function, start with the specified bit in ON state (set).	The port number, the OFF and the ON times (in seconds), both as 16-bit integers.	Result (OK or ERROR).

a. See also “Notifications” on page 53.

RETURNS	The return result depends on the control byte. However, whatever the return result is, it includes the control byte.
REMARKS	The general behavior is that a <code>PORT</code> command issued on a certain port bit will override any previous <code>PORT</code> commands. For example, if a port was configured as input and then an MFR (monostable function) was issued, the port automatically switches to output. A new MFR or similar function clears the status of the port and starts from scratch, even if the previous command was not finished.
REMOTE	Yes, for the A720 and A723. If you are using a terminal window for the A720, you cannot issue the <code>PORT</code> command. If you are using a terminal window for the A720B, you can issue a <code>PORT</code> command remotely for an A720 or A723 RTU, but you cannot issue the command for the A720B receiver. In other words, the base station can issue a remote command for an RTU, but it cannot issue such a command for itself. An RTU cannot issue the command at all, but can execute it. An exception is the A723 RTU that accepts this commands also over the serial line.
EXAMPLE	<p>For RDP:</p> <pre>6789 PORT 0 6789 PORT 0 1 0 #</pre> <p>For RDDR:</p> <pre>6789 PORT 16 6789 PORT 16 0 0 #</pre> <p>For ENOPC:</p> <pre>6789 PORT 112 6789 PORT 112 0 #</pre> <p>For RPNNER:</p> <pre>6789 PORT 128 6789 PORT 128 0 1 0 #</pre>

For **RNS**:

```
6789 PORT 80
6789 PORT 7/5/1999 18:34:22 0
#
```

COMMAND	RX
APPLIES TO	A720, A720B, A723
DESCRIPTION	Switches the unit to permanent receive mode (for tuning purposes).
PARAMETERS	None.
RETURNS	Nothing.
REMARKS	The system stops, and exits the command only when you press a key. This command returns no message.
REMOTE	No.
EXAMPLE	RX 193 RX 0 #

COMMAND	TX
APPLIES TO	A720, A720B, A723
DESCRIPTION	Switches the unit to transmit mode (for tuning purposes).
PARAMETERS	None (sends an unmodulated carrier), 1 (sends a 1 kHz modulated carrier), 0 (sends a 2 kHz modulated carrier) or 5 (sends a mixed 1 + 2 kHz modulated carrier).
RETURNS	Nothing.
REMARKS	The system stops, and exits the command only when you press a key. This command returns no message.
REMOTE	No.
EXAMPLE	TX 193 TX 0 #

	TX 1
	193 TX 0
	#
	TX 5
	193 TX 0
	#
COMMAND	B
APPLIES TO	A720, A723
DESCRIPTION	Sends a broadcast frame.
PARAMETERS	None.
RETURNS	A data block.
REMARKS	After the device sends the broadcast frame, it will listen for answers. All valid answers will be listed with their IDs.
REMOTE	Yes, but only for the A723. A remote broadcast command instructs the remote to issue a broadcast (the remote must support this function). A subsequent BLST command retrieves a list of stations that the remote heard after issuing the broadcast frame.
EXAMPLE	B 6789 B 0 #234 BA 0 #7851 BA 0 15190 B 15190 B 0 #
COMMAND	BLST
APPLIES TO	A723
DESCRIPTION	Retrieves a list with stations heard after the last broadcast command.
PARAMETERS	None.
RETURNS	A data block.
REMARKS	None.

REMOTE Yes (the remote must support this function).

EXAMPLE

```

BLST
6789 BLST 30/8/2001 16:03:41 4
15190 255 255
2419 255 201
10836 247 187
10805 255 187
0
#

15190 BLST
15190 BLST 30/8/2001 16:03:41 6
15193 255 0
7852 255 0
14640 255 0
2419 255 0
9476 255 0
10836 255 0
0
#

```

COMMAND **VER**

APPLIES TO A720, A720B, A723

DESCRIPTION Requests the firmware version of the device.

PARAMETERS None.

RETURNS The current version.

REMARKS **GET** only.

REMOTE No.

EXAMPLE

```

VER
234 VER 1.3 0
#

VER
6789 VER 2.0 0
#

```

Note: This command is provided only for compatibility with older units. The software may use this command to identify the

unit it is communicating with. After detecting that the device supports this protocol, the INFO command must be used for further details.

Notifications

Notifications are frames sent asynchronously by devices that are otherwise slaves. The notifications are received by a device closest to the host and then sent to the host. If the host is not available, the receiving device will store the notification and wait until it is questioned by the host. At this point, it will inform the host that it has a notification. It is then the task of the host to issue a command to read the respective notification.

Before a device can issue a notification, the notification must first be enabled. Special frames are used to this end, depending on the notification type. If an end device is not able to send a notification due to radio propagation or other kind of communication problems, it will store the date/time when the notification took place. As soon as the communication is re-established, the device will try to send the notification again.

Note: To avoid collisions, the device will wait a random time (up to 10 seconds) before sending the notification frame.

When the device closest to the host receives a notification from a remote, it must inform the host about it by sending a break character on the serial line. The host must then issue the command DEV in order to see which device has a notification pending (see also "DEV" on page 35). If the host is not available, the device closest to the host will wait until first time requested by the host and after answering to the host request will re-send a break. This sequence will go on as described until the host issues the DEV command.

The following notification is currently defined for the A720 device:

- NOPC—Notification On Port Change (see "PORT" on page 46).

In addition to this notification, the A723 devices can issue the following:

- NOTR—Notification On Threshold Reached (see "ANLG" on page 43)

The A720B device does not currently recognize notifications.

Returned errors list

Following are error messages you might get.

Command line interpreter

- 1 — nonexistent command
- 2 — command line buffer overflow (input line too long)
- 3 — internal error
- 4 — reserved
- 5 — missing or false parameters in command
- 6 — operation not implemented

Device descriptors and storage handler

- 10 — device not found (attempt to perform a command on a nonexistent device)
- 11 — device already exists
- 12 — reserved
- 13 — no more space for descriptors (too many devices)
- 14 — no more records for the specified device
- 15 — temporary communication break, no more data (the last request was not successful)
- 16 — time-out (the handler blocked or is busy)
- 17 — internal error
- 18 — attempt to insert a reserved device ID number (0 or 65535)

Real time clock

- 20 — incorrect time supplied (conversion to `time_t` was not possible)

Radio interface

- 30 — error at receive (CRC, etc.)
- 31 — unexpected frame received
- 32 — wrong length
- 33 — reserved
- 34 — reserved
- 35 — time-out (remote device not responding)

Notifications

- 36 — receiver busy (for example, just making the request round)
- 40 — request to read a notification when no notification is pending

Appendix. Specifications

The A720 series was intended to fulfill the specification of the ETSI 300 220, Class I, Subclasses a and b, but other national norms are similar to this (for example, the CFR 47, Part 90, Subpart J). Table 6 shows the main operational parameters of the A720 series.

Table 6. Operational Parameters

Parameter	Min	Typ	Max	Unit
Common				
Supply	5.0	6.2	10.0	V
Operating Temperature	-30		+70	°C
Relative Humidity	10		99	%
Class Protection		IP65		
Data Rate (using the onboard software modem)	1000	150 ^a	2000	bps
Operating Frequency (low band version) ^b	432		450	MHz
Operating Frequency (high band version) ^b	450		470	MHz
Frequency Stability (-20 to +60 °C)			±1.5	kHz
Frequency Stability (-30 to +70 °C)			±2.5	kHz

Table 6. Operational Parameters (Continued)

Parameter	Min	Typ	Max	Unit
Receiver				
Sensitivity (10 db S/N)		-93 (A720) -105(A723)		dBm
Image Frequency Attenuation (1st IF = 45 MHz)	35			dB
Local Oscillator Leakage			2	nW
Adjacent Channel Attenuation (both versions)	55			dB
RSSI Dynamic	90			dB
Operating Current (incl. onboard microcontroller) ^c			15	mA
Transmitter (all measurements made on a 50 Ω resistive load)				
Output Power	7	9	10	dBm
Spurious Radiation (0 to 862 MHz)			2	nW
Spurious Radiation (862 MHz to 3.5 GHz)			200	nW
Adjacent Channel Power (12.5 kHz version)			-32	dBm
Adjacent Channel Power (25 kHz version)			-44	dBm
Occupied Bandwidth (12.5 kHz version)			8.5	kHz
Occupied Bandwidth (25 kHz version)			15	kHz
Operating Current (incl. onboard microcontroller)			50	mA
A720/A723 only				
Analog Inputs	0		2.5	V
Analog to Digital Converter Resolution		8 (A720) 10 (A723)		bits
Digital Inputs V_{il}			0.5	V
Digital Inputs V_{ih}	2.5			V
Pulse Counter Input Frequency ^d			1.5	Hz
Pulse Counter Resolution		8 (A720) 16 (A723)		bits
Digital Outputs Sink/Source			2	mA
Digital Outputs V_{ol}			0.3	V
Digital Outputs V_{oh}	2.9			V

- a. Data rate is content dependent.
- b. This parameter represents the tuning range; the switching range may be limited in the software to a narrower space (even to the extent of a single channel).
- c. Continuous duty.
- d. Electrical levels are the same as for the Digital Inputs.

Index

A

- A720 description, 5
- A720B description, 5
- about the LED, 16
- ANLG, 43
- answer format, 25

B

- B
 - series 1, 30
 - series 2, 51
- base station
 - composition, 9
 - graphic, 12
 - installation issues, 10
 - packaging, 9
- battery
 - changing, 19
 - description, 17
 - operation, 18

- BLST, 51

C

- changing the battery, 19
- CMDS, 30
- command
 - ANLG, 43
 - B
 - series 1, 30
 - series 2, 51
 - BLST, 51
 - CMDS, 30
 - DATA, 36
 - DEL, 36
 - DEV, 35
 - DUMP, 29
 - FDEV, 41
 - format, 25
 - FREQ
 - series 1, 28
 - series 2, 31
 - ID, 32
 - IMME, 40

INFO, 41
 OWNID, 26
 PMP
 series 1, 27
 series 2, 33
 PORT, 46
 query parameters, 29
 REPL, 35
 ROUTE, 40
 RSSI
 series 1, 28
 series 2, 31
 RX
 series 1, 29
 series 2, 50
 SLOT
 series 1, 27
 series 2, 32
 SST, 34
 TIME, 30
 TX, 50
 VER
 series 1, 29
 series 2, 52
 XMIT, 29
 command line interpreter errors, 54
 configuring
 addIT RTU in addVANTAGE software, 17
 addVANTAGE Lite software, 12
 devices, 24
 connectivity check, 14
 connector
 definition, 22
 receiver, 22
 RTU, 23
 conventions, document, 7

D

DATA, 36
 DEL, 36
 DEV, 35
 device
 configuration, 24

 descriptors and storage handler errors, 54
 determining version, 22
 operation time, 18
 document conventions, 7
 DUMP, 29

E

errors
 command line interpreter, 54
 device descriptors and storage handler,
 54
 radio interface, 54
 real time clock, 54

F

FDEV, 41
 field installation, RTU, 15
 formats, 25
 FREQ
 series 1, 28
 series 2, 31

I

ID, 32
 IMME, 40
 INFO, 41
 install
 power supply, 11–12
 receiver, 11
 RTU, 14
 installation issues, 6
 internal battery, 17
 introduction, 5

L

LED
 definition, 14
 usage, 16

M

maintaining the RTU, 17

N

NOPC, 53
notification
 definition, 53
 NOPC, 53

O

overview, 5
OWNID, 26

P

packaging
 base station, 9
 RTU, 13
performing a connectivity check, 14
placing a base station, 10
PMP
 series 1, 27
 series 2, 33
PORT, 46
power supply
 graphic, 11
 installing, 11–12

Q

querying command parameters, 29

R

radio interface errors, 54
real time clock errors, 54
receiver
 connector, 22
 graphic, 10
 installing, 11

remote transmission unit. *See* RTU
REPL, 35

restrictions for installation, 6

ROUTE, 40

RSSI

 series 1, 28
 series 2, 31

RTU

 connector, 23
 field installation, 15
 graphic, 14
 installing, 14
 maintenance, 17
 packaging, 13
 use, 13

RX

 series 1, 29
 series 2, 50

S

series, determining, 22

SLOT

 series 1, 27
 series 2, 32

software configuration, 12, 17

SST, 34

T

TIME, 30

TX, 50

U

using

 LED for connectivity check, 14
 RTU, 13

V

VER

 series 1, 29
 series 2, 52

W

what a base station contains, 9

X

XMIT, 29

Credits and Colophon

Credits

Development

Günther Leber, Lix N. Paulian, Florin Wacykiewicz, Matthias Wallner.

Documentation and artwork

Dimi Everette, Stefan Hasegan, Lix N. Paulian.

Quality control and testing

Steve Grove, Martin Hackl, Bernd Hartmann, Günther Leber, Lix N. Paulian, Matthias Wallner.

Colophon

This manual was written and produced with Adobe FrameMaker on the MacOS platform. The illustrations were done or prepared in Adobe Illustrator and Adobe Photoshop on a Power Macintosh. Some illustrations were done in Corel Draw! on Microsoft Windows. The electronic version was created with Adobe Distiller on a Power Macintosh.

