



Your Reliable Partner

IS-10/IS-11/IS-12/IS-20

*Intel Pentium 4 System Board
Socket 478*

User's Manual

4200-0383-03
Rev. 1.01

Copyright and Warranty Notice

The information in this document is subject to change without notice and does not represent a commitment on part of the vendor, who assumes no liability or responsibility for any errors that may appear in this manual.

No warranty or representation, either expressed or implied, is made with respect to the quality, accuracy or fitness for any particular part of this document. In no event shall the manufacturer be liable for direct, indirect, special, incidental or consequential damages arising from any defect or error in this manual or product.

Product names appearing in this manual are for identification purpose only and trademarks and product names or brand names appearing in this document are property of their respective owners.

This document contains materials protected under International Copyright Laws. All rights reserved. No part of this manual may be reproduced, transmitted or transcribed without the expressed written permission of the manufacturer and authors of this manual.

Table Of Contents

Chapter 1. Introduction	1-1
1.1. Features & Specifications.....	1-1
1.2. Layout.....	1-3
1.3. Jumpers & Connectors Description.....	1-4
Chapter 2. Hardware Setup.....	2-1
2.1. Install The Motherboard.....	2-1
2.2. Install Pentium® 4 CPU and Heatsink Supporting-Base.....	2-2
2.3. System Memory	2-3
2.3.1. Memory Configuration Table.....	2-3
2.3.2. Installing and Removing Memory Modules.....	2-4
2.4. Connectors, Headers, and Switches	2-5
2.4.1. ATX Power Connectors.....	2-5
2.4.2. FAN Power Connectors.....	2-6
2.4.3. CMOS Memory Clearing Header.....	2-7
2.4.4. AGP Display Card Slot (<i>IS-10/IS-11/IS-12</i>).....	2-8
2.4.5. Front Panel Switches & Indicators Connection Headers	2-9
2.4.6. Front Panel Audio Connection Header.....	2-10
2.4.7. Additional USB Port Connection Headers	2-11
2.4.8. System Management Bus Connection Header	2-12
2.4.9. Additional IEEE1394 Port Connection Headers (<i>IS-12</i>)	2-13
2.4.10. Internal Audio Source Connectors	2-14
2.4.11. Floppy and IDE Disk Drive Connectors.....	2-15
2.4.12. Serial ATA Connectors.....	2-16
2.4.13. CPU Core Voltage Selector.....	2-17
2.4.14. External I/O Panel Connectors	2-18

Chapter 3. BIOS Setup.....	3-1
3.1. Standard CMOS Features.....	3-2
3.2. Advanced BIOS Features.....	3-6
3.3. Advanced Chipset Features.....	3-8
3.4. Integrated Peripherals.....	3-10
3.5. Power Management Setup.....	3-17
3.6. PnP/PCI Configurations.....	3-19
3.7. PC Health Status.....	3-21
3.8. Load Fail-Safe Defaults.....	3-22
3.9. Load Optimized Defaults.....	3-22
3.10. Set Supervisor Password.....	3-22
3.11. Set User Password.....	3-22
3.12. Save & Exit Setup.....	3-22
3.13. Exit Without Saving.....	3-22
Chapter 4. Driver Installation.....	4-1
4.1. Setup Items.....	4-2
Appendix A. How to Get Technical Support.....	A-1

Chapter 1. Introduction

1.1. Features & Specifications

Processor

- Supports Intel Pentium 4 Socket 478 processors with 800/533/400MHz Front Side Bus
- Supports Intel Hyper-Threading Technology

Chipset

- Intel 865G / ICH5 (*IS-10/IS-11/IS-12*)
- Intel 865GV / ICH5 (*IS-20*)
- Integrated Intel Extreme Graphics 2
- Supports Advanced Configuration and Power Interface (ACPI)

Memory

- Two 184-pin DIMM sockets
- Supports 2 DIMM Single / Dual Channel DDR 400/333/266 memory (Max. 2GB)

Graphics

- Integrated Intel Extreme Graphics 2
- Accelerated Graphics Port connector supports AGP 8X/4X (0.8V/1.5V) (*IS-10/IS-11/IS-12*)

Serial ATA

- 2-Channel Serial ATA with 150MB/s data transfer rate

Audio

- 6-Channel AC 97 CODEC on board
- Professional digital audio interface supports optical S/PDIF Output

System BIOS

- Supports Plug-and-Play (PNP)
- Supports Advanced Configuration Power Interface (ACPI)
- Supports Desktop Management Interface (DMI)
- Write-Protect Anti-Virus function by AWARD BIOS

LAN

- Onboard 10/100Mb LAN (*IS-10/IS-12/IS-20*)

- Onboard Gigabit LAN (*IS-11*)

Internal I/O Connectors

- 1x AGP (*IS-10/IS-11/IS-12*)
- 3x PCI slots
- 1x Floppy Port supports up to 2.88MB
- 2x Ultra DMA 33/66/100 Connectors
- 2x Serial ATA 150 Connectors
- 2x USB 2.0 Headers (Each header support two USB 2.0 devices)
- 1x CD-IN, 1x AUX-IN Header
- 1x FP-Audio header
- 2x IEEE1394 Headers (*IS-12*)

External I/O Connectors

- 1x PS/2 Keyboard, 1x PS/2 Mouse
- 1x Printer Port, 1x COM Port
- 1x VGA Port
- 1x AUDIO Connector (Rear-Left / Rear-Right, Center/Subwoofer, S/PDIF Output, Mic-In, Line-In, Front-Left/Front-Right)
- 2x USB 2.0 Connectors
- 2x USB 2.0 Connectors, 1x RJ-45 LAN Connector

Miscellaneous

- Micro ATX Form Factor (244mm x 234mm)
- Hardware Monitoring - including Fan Speed, Voltages, CPU and System Temperature

※ **Specifications and information contained herein are subject to change without notice.**

1.2. Layout

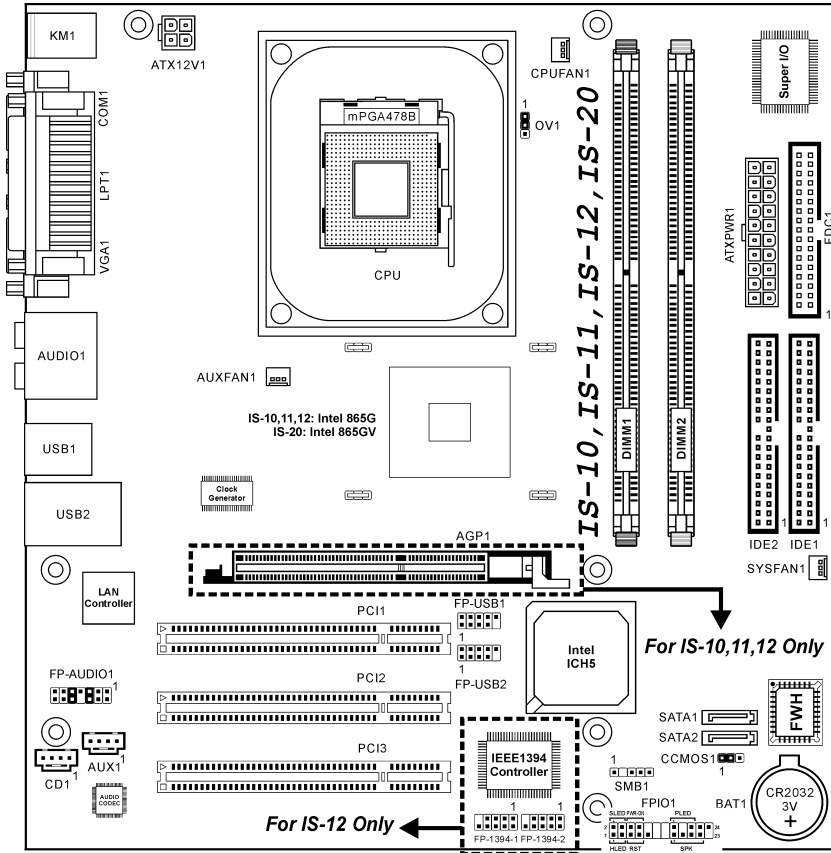

1.3. Jumpers & Connectors Description

Jumpers	Description	Default Setting
CCMOS1	CMOS Memory Clearing Header	Pins 1-2 Closed (Normal)
OV	CPU Core Voltage Selector	Pins 1-2 Closed (Normal)

Connectors	Description
AGP1	AGP Display Card Slot (<i>IS-10/IS-11/IS-12</i>)
ATXPWR1/ATX12V1	ATX Power Connectors
CD1/AUX1	Internal Audio Sources Connectors
CPUFAN1	CPU Fan Power Connector
SYSFAN1	System Fan Power Connector
AUXFAN1	Auxiliary Fan Power Connector
DIMM1/DIMM2	DDR DIMM Slots
FDC1	Floppy Disk Drive Connector
FP-1394-1/FP-1394-2	Additional IEEE1394 Port Connection Headers (<i>IS-12</i>)
FP-AUDIO1	Front Panel Audio Connection Header
FPIO1	Front Panel Switches & Indicators Connection Headers
FP-USB1/FP-USB2	Additional USB Port Connection Header
IDE1/IDE2	Hard Disk Drive Connectors
PCI1/PCI2/PCI3	32bit/33MHz PCI Slots
SATA1/SATA2	Serial ATA Connectors
SMB1	System Management Bus Connection Header

Chapter 2. Hardware Setup

Before the Installation: Turn off the power supply switch (fully turn off the +5V standby power), or disconnect the power cord before installing or unplugging any connectors or add-on cards. Failing to do so may cause the motherboard components or add-on cards to malfunction or damaged.

2.1. Install The Motherboard

Most computer chassis have a base with many mounting holes to allow motherboard to be securely attached on and at the same time, prevented from short circuits. There are two ways to attach the motherboard to the chassis base:

1. use with studs
2. or use with spacers

In principle, the best way to attach the board is to use with studs. Only if you are unable to do this should you attach the board with spacers. Line up the holes on the board with the mounting holes on the chassis. If the holes line up and there are screw holes, you can attach the board with

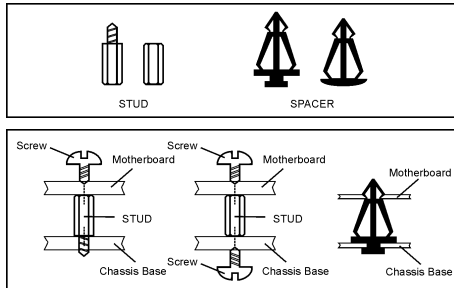

studs. If the holes line up and there are only slots, you can only attach with spacers. Take the tip of the spacers and insert them into the slots. After doing this to all the slots, you can slide the board into position aligned with slots. After the board has been positioned, check to make sure everything is OK before putting the chassis back on.

ATTENTION: To prevent shorting the PCB circuit, please REMOVE the metal studs or spacers if they are already fastened on the chassis base and are without mounting-holes on the motherboard to align with.

2.2. Install Pentium® 4 CPU and Heatsink Supporting-Base

This motherboard provides a ZIF (Zero Insertion Force) Socket 478 to install Intel® Pentium® 4 CPU. The CPU you bought should have a kit of heatsink and cooling fan along with. If that's not the case, buy one specially designed for Pentium® 4 Socket 478.

1. Locate the 478-pin ZIF socket on the motherboard. Fasten the Retention Module Base onto the motherboard.

ATTENTION: If you are using chassis specially designed for Pentium® 4, please pay attention to the location of Metal Studs or Spacers if they are already installed on the chassis. Be careful not let the Metal Studs or Spacers contact the printed circuit wire or parts on the PCB.

2. Pull the CPU socket lever sideways away from the socket and then upwards to 90 degree. Insert the CPU with the correct orientation. Do not use extra force to insert CPU; it only fits in one orientation. Close down the socket lever while holding down the CPU.
3. Put the heatsink faces down onto the CPU until it completely covers the CPU.
4. Put the Fan and Retention Mechanism Assembly onto the heatsink. Make sure all the four Retention Locks at each side of the Fan and Retention Mechanism Assembly snap into the Retention Holes.

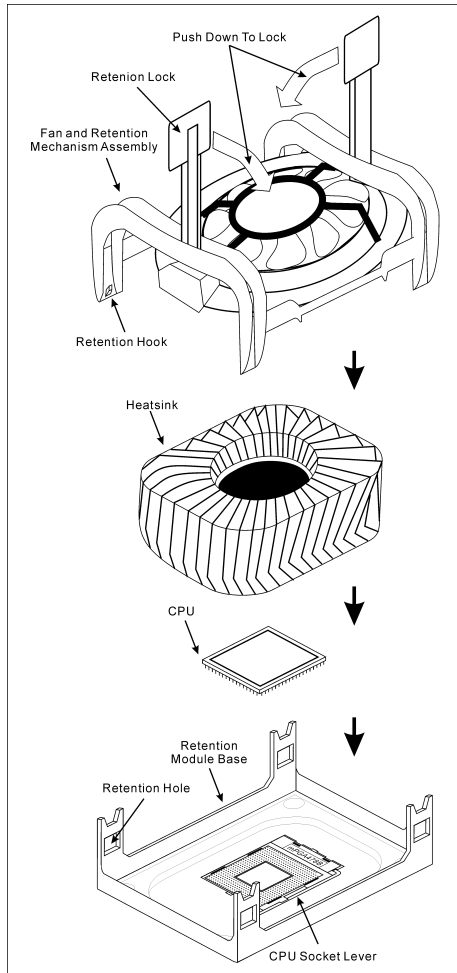

5. Push down the Retention Lock at both sides of the Fan and Retention Mechanism Assembly to lock up together with the Retention Module Base.
6. The Fan and Retention Mechanism Assembly and Retention Module Base should now firmly lock up with each other with the heatsink inside.

ATTENTION: Do not forget to set the correct bus frequency and multiple for your processor.

2.3. System Memory

This system board provides two 184-pin DDR DIMM slots for DDR 400/333/266 memory modules with memory expansion size up to 2GB.

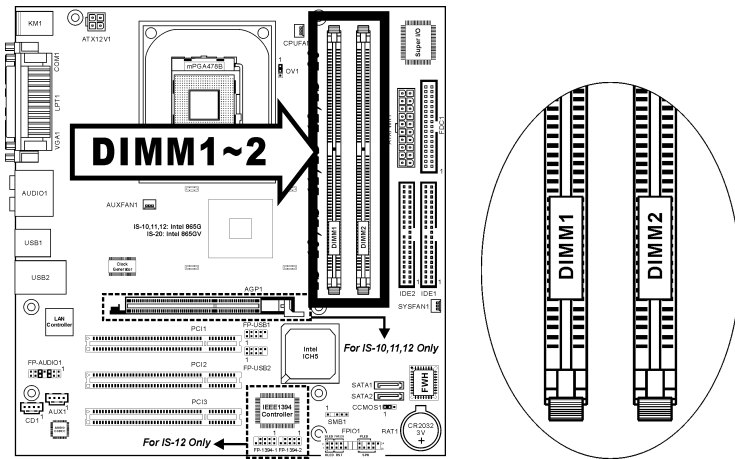

2.3.1. Memory Configuration Table

DIMM	DIMM Module	Total Memory
1	128MB, 256MB, 512MB, 1GB	128MB ~ 1GB
2	128MB, 256MB, 512MB, 1GB	128MB ~ 1GB
Total System Memory		128MB ~ 2GB

2.3.2. Installing and Removing Memory Modules

Power off the computer and unplug the AC power cord before installing or removing memory modules.

1. Locate the DIMM slot on the board.
2. Hold two edges of the DIMM module carefully, keep away of touching its connectors.
3. Align the two notch keys on the module with the two ribs on the slot.
4. Firmly press the module into the slots until the ejector tabs at both sides of the slot automatically snaps into the mounting notch. Do not force the DIMM module in with extra force as the DIMM module only fit in one orientation.
5. To remove the DIMM modules, push the two ejector tabs on the slot outward simultaneously, and then pull out the DIMM module.

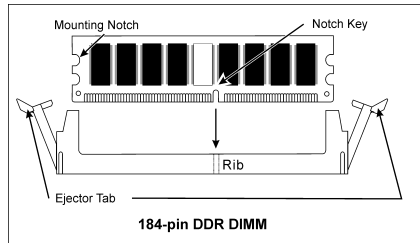

ATTENTION: As the static electricity can damage the electronic components of the computer or optional modules, make sure you are discharged of static electricity by touching a grounded metal object briefly before starting these procedures.

2.4. Connectors, Headers, and Switches

All the connectors, headers and switches mentioned here are depending on your system configuration. Some features you may (or may not) have to connect or to configure depending on the peripherals you have connected.

WARNING: Always power off the computer and unplug the AC power cord before adding or removing any peripheral or component. Failing to do so may cause severe damage to your system board and/or peripherals. Plug in the AC power cord only after you have carefully checked everything.

2.4.1. ATX Power Connectors

It would be recommended to supply an ATX12V power with 300W, 20A +5VDC capacity at least for heavily loaded system, and 720mA +5VSB at least for supporting Wake-On-LAN feature.

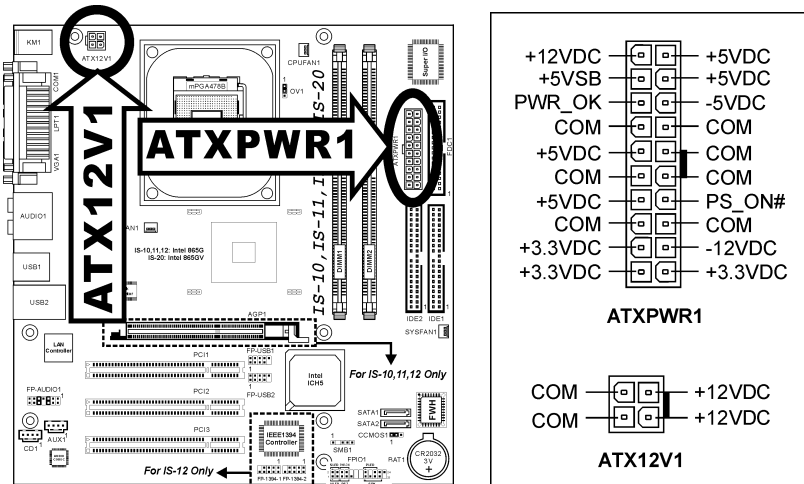

2.4.2. FAN Power Connectors

These 3-pin connectors each provide power to the cooling fans installed in your system.

The CPU must be kept cool by using a powerful fan with heatsink. The system is capable of monitoring the speed of the CPU fan.

- **CPUFAN1:** CPU Fan Power Connector
- **SYSFAN1:** System Fan Power Connector
- **AUXFAN1:** Auxiliary Fan Power Connector

WARNING: These fan connectors are not jumpers. DO NOT place jumper caps on these connectors.

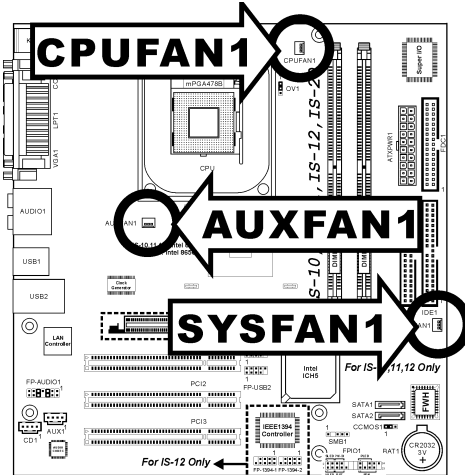

2.4.3. CMOS Memory Clearing Header

This header uses a jumper cap to clear the CMOS memory.

- **Pin 1-2 shorted (default):** Normal operation.
- **Pin 2-3 shorted:** Clear CMOS memory.

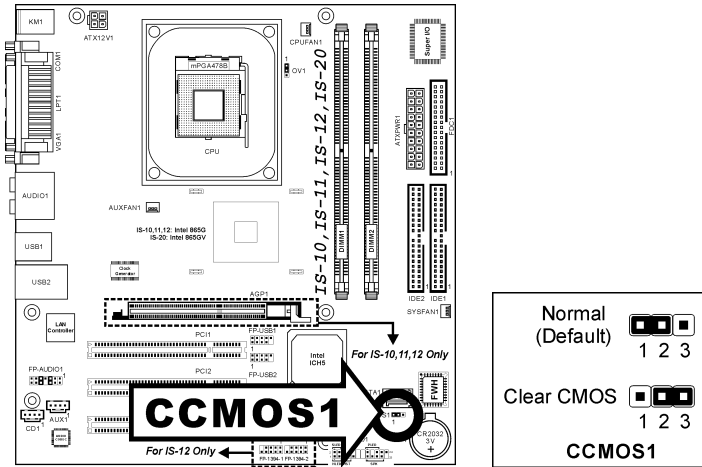

ATTENTION: Turn the system power off first (including the +5V standby power) before clearing the CMOS memory. Failing to do so may cause your system to work abnormally or malfunction.

2.4.4. AGP Display Card Slot (IS-10/IS-11/IS-12)

This slot supports an optional AGP graphics card up to AGP 4X/8X mode.

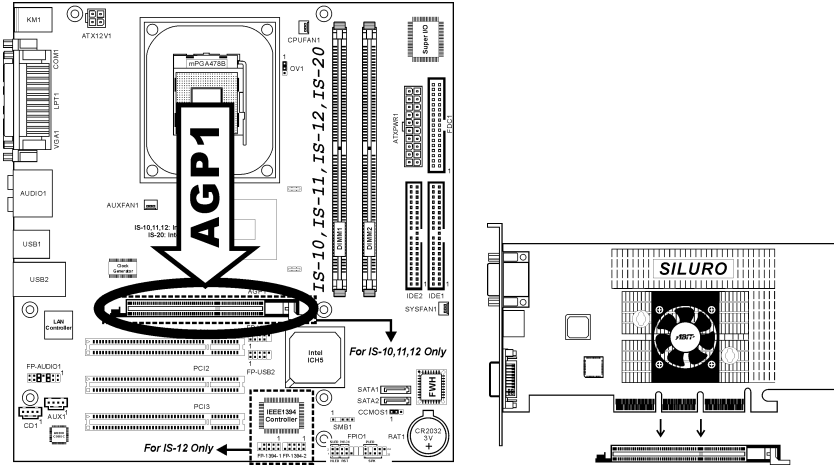

ATTENTION: This motherboard does not support 3.3V AGP cards. Use only 1.5V or 0.8V AGP cards.

2.4.5. Front Panel Switches & Indicators Connection Headers

These headers are used for connecting switches and LED indicators on the chassis front panel. The mark “+” align to the pin in the figure below stands for positive polarity for the LED connection.

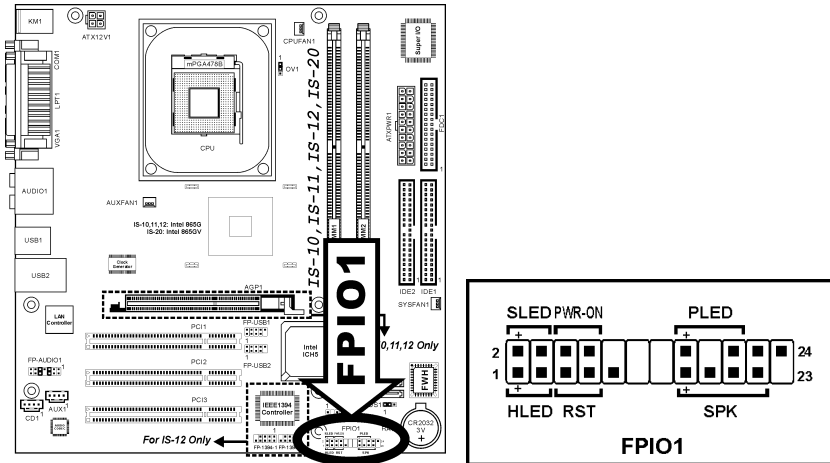

- **HLED (Pin 1, 3):**
Connects to the HDD LED cable of chassis front panel.
- **RST (Pin 5, 7):**
Connects to the Reset Switch cable of chassis front panel.
- **SPK (Pin 15, 17, 19, 21):**
Connects to the System Speaker cable of chassis.
- **SLED (Pin 2, 4):**
Connects to the Suspend LED cable (if there is one) of chassis front panel.
- **PWR-ON (Pin 6, 8):**
Connects to the Power Switch cable of chassis front panel.
- **PLED (Pin 16, 18, 20):**
Connects to the Power LED cable of chassis front panel.

2.4.6. Front Panel Audio Connection Header

This header provides the connection to audio connector located at front panel.

- To use the audio connector at front panel, remove all the jumpers on this header, and then connect to front panel by the extension cable provided with the chassis.
- To use the audio connector at rear panel, disconnect the extension cable, attach the jumpers back at pin 5-6, and pin 9-10 (default setting).

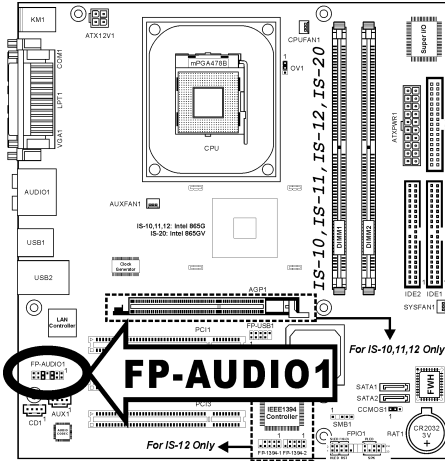

Pin	Pin Assignment	Pin	Pin Assignment
1	Audio Mic.	2	Ground
3	Audio Mic. Bias	4	VCC
5	Speaker Out Right Channel	6	Speaker Out Right Channel Return
7	X	8	NC
9	Speaker Out Left Channel	10	Speaker Out Left Channel Return
11	Ground	12	S/PDIF In
13	VCC	14	S/PDIF Out

2.4.7. Additional USB Port Connection Headers

These headers each provide two additional USB port connections.

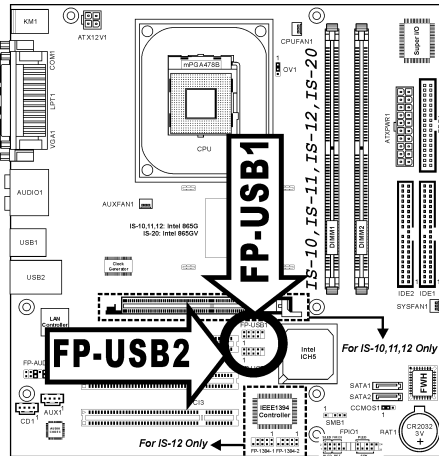

	Pin	Pin Assignment	Pin	Pin Assignment
<p>FP-USB1 FP-USB2</p>	1	VCC	2	VCC
	3	Data0 -	4	Data1 -
	5	Data0 +	6	Data1 +
	7	Ground	8	Ground
	9	NC	10	NC

2.4.8. System Management Bus Connection Header

This header provides one additional System Management Bus connection.

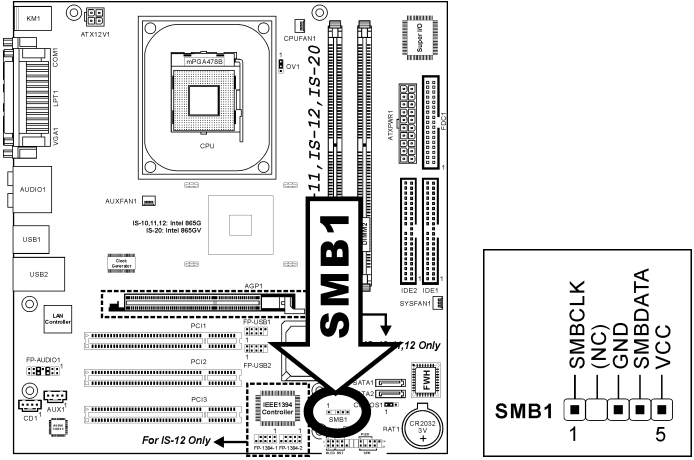

2.4.9. Additional IEEE1394 Port Connection Headers (IS-12)

These headers each provide one additional IEEE1394 port connection.

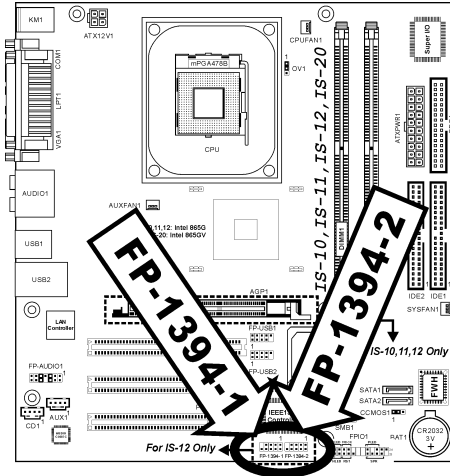

	Pin	Pin Assignment	Pin	Pin Assignment
<p>7 5 3 1 10 8 6 4 2 FP-1394-1 FP-1394-2</p>	1	TPA0 +	2	TPA0 -
	3	GND	4	GND
	5	TPB0 +	6	TPB0 -
	7	+12V	8	+12V
	9	NC	10	GND

2.4.10. Internal Audio Source Connectors

These connectors provide the connection to the audio output of internal CD-ROM drive or add-on audio card.

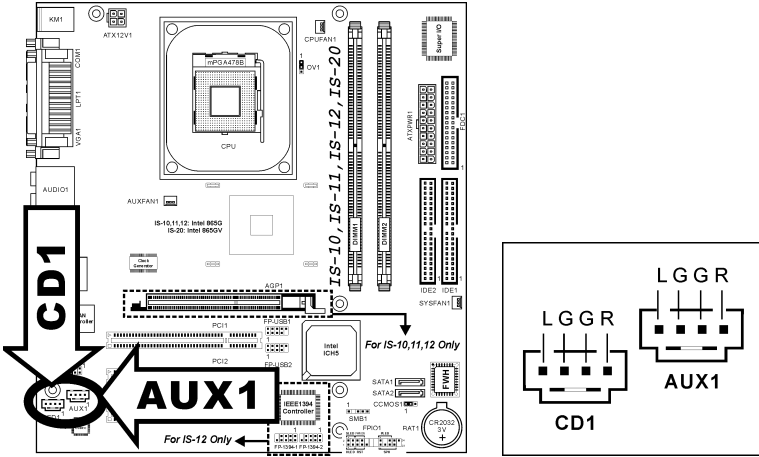

2.4.11. Floppy and IDE Disk Drive Connectors

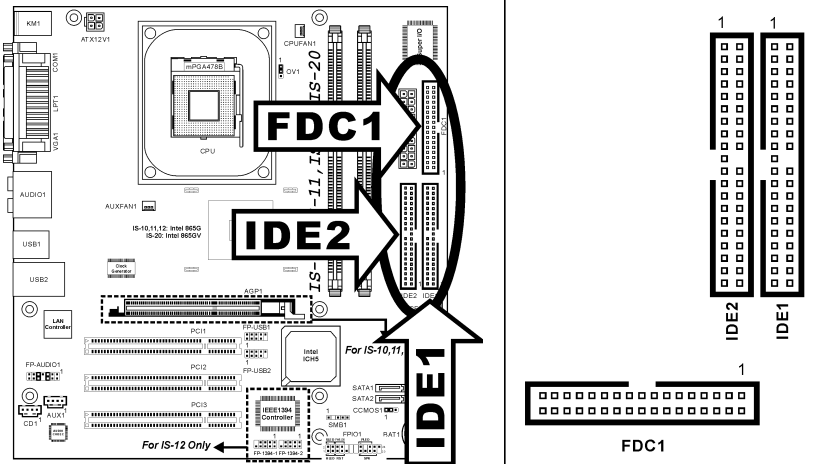

The FDC1 connector connects up to two floppy drives with a 34-wire, 2-connector floppy cable. Connect the single end at the longer length of ribbon cable to the FDC1 on the board, the two connectors on the other end to the floppy disk drives connector. Generally you need only one floppy disk drive in your system.

NOTE: The red line on the ribbon cable must be aligned with pin-1 on both the FDC1 port and the floppy connector.

Each of the IDE port connects up to two IDE drives at Ultra ATA/100 mode by one 40-pin, 80-conductor, and 3-connector Ultra ATA/66 ribbon cables.

Connect the single end (blue connector) at the longer length of ribbon cable to the IDE port of this board, the other two ends (gray and black connector) at the shorter length of the ribbon cable to the connectors of your hard drives.

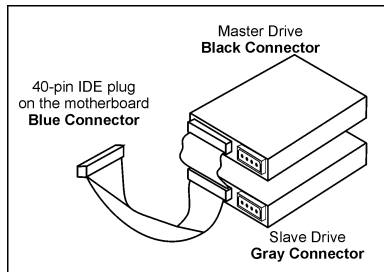

NOTE: Make sure to configure the “Master” and “Slave” relation before connecting two drives by one single ribbon cable. The red line on the ribbon cable must be aligned with pin-1 on both the IDE port and the hard-drive connector.

2.4.12. Serial ATA Connectors

These connectors each provide one Serial ATA channel connection.

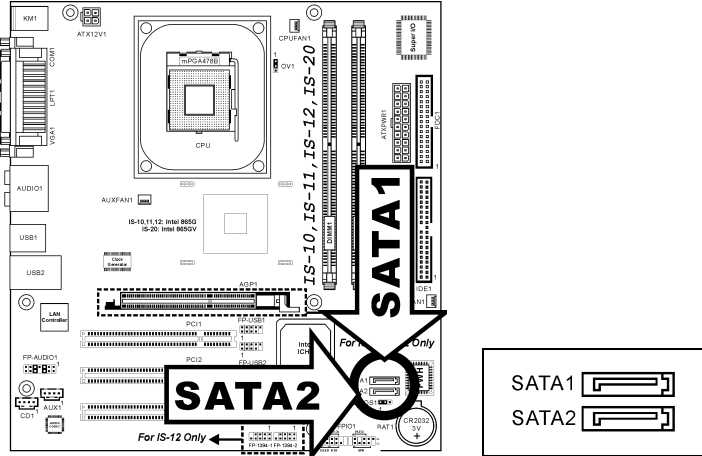

2.4.13. CPU Core Voltage Selector

This header uses a jumper to adjust the CPU core voltage.

- **Pin 1-2 shorted (default):** Normal operation.
- **Pin 2-3 shorted:** Raise the CPU core voltage by 0.1V.

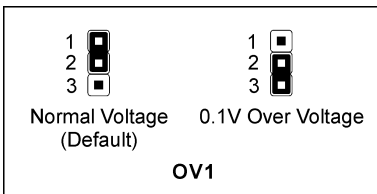
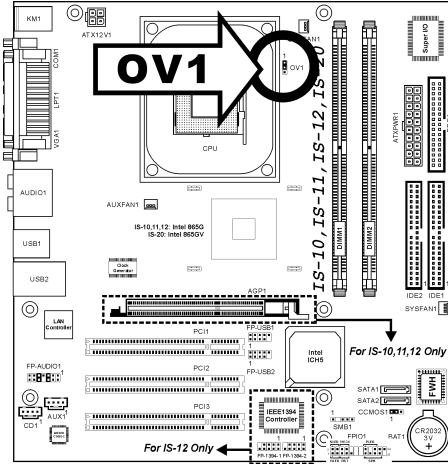

2.4.14. External I/O Panel Connectors

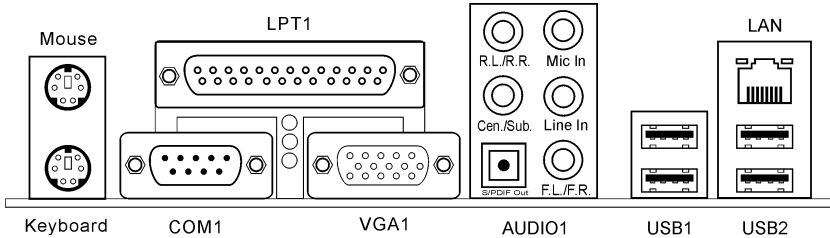

- **Mouse:** Connects to PS/2 mouse.
- **Keyboard:** Connects to PS/2 keyboard.
- **LPT1:** Connects to printer or other devices that support this communication protocol.
- **COM1:** Connects to external modem, mouse or other devices that support this communication protocol.
- **VGA1:** Connects to monitor input.
- **AUDIO1:**
 - R.L./R.R. (Rear Left / Rear Right):** Connects to the rear left and rear right channel in the 5.1 channel audio system.
 - Cen./Sub. (Center / Subwoofer):** Connects to the center and subwoofer channel in the 5.1 channel audio system.
 - S/PDIF Out:** This connector provides an S/PDIF out connection through optical fiber to digital multimedia devices.
 - Mic In:** Connects to the plug from external microphone.
 - Line In:** Connects to the line out from external audio sources.
 - F.L./F.R. (Front Left / Front Right):** Connects to the front left and front right channel in the 5.1-channel or regular 2-channel audio system.
- **LAN:** Connects to Local Area Network.
- **USB1/USB2:** Connects to USB devices such as scanner, digital speakers, monitor, mouse, keyboard, hub, digital camera, joystick etc.

Chapter 3. BIOS Setup

This motherboard provides a programmable EEPROM that you can update the BIOS utility. The BIOS (Basic Input/Output System) is a program that deals with the basic level of communication between processor and peripherals. Use the BIOS Setup program only when installing motherboard, reconfiguring system, or prompted to “Run Setup”. This chapter explains the Setup Utility of BIOS utility.

After powering up the system, the BIOS message appears on the screen, the memory count begins, and then the following message appears on the screen:

Press DEL to run setup

If this message disappears before you respond, restart the system by pressing <Ctrl> + <Alt> + keys, or by pressing the Reset button on computer chassis. Only when it failed by these two methods can you restart the system by powering it off and then back on.

After pressing key, the main menu screen appears.

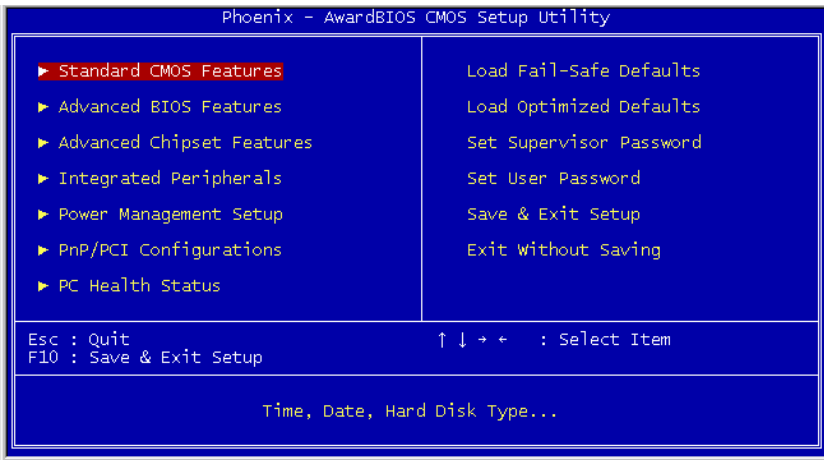

NOTE: In order to increase system stability and performance, our engineering staffs are constantly improving the BIOS menu. The BIOS setup screens and descriptions illustrated in this manual are for your reference only, may not completely match what you see on your screen.

3.1. Standard CMOS Features

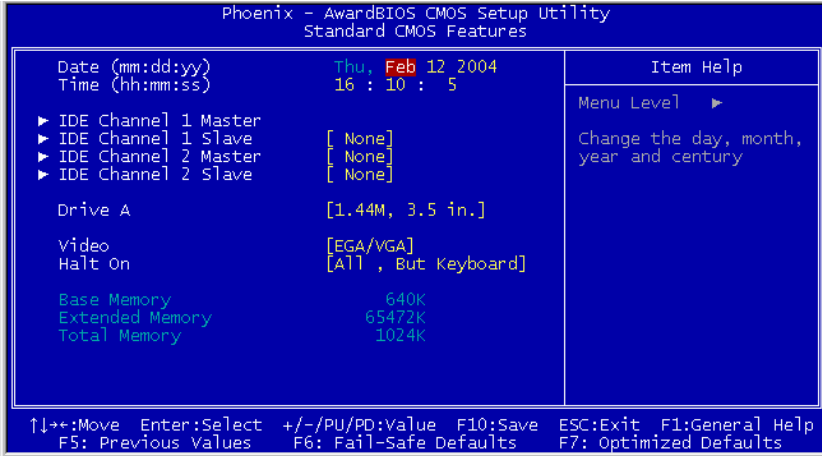

Date (mm:dd:yy)

This item sets the date you specify (usually the current date) in the format of [Month], [Date], and [Year].

Time (hh:mm:ss)

This item sets the time you specify (usually the current time) in the format of [Hour], [Minute], and [Second].

IDE Channel 1 Master/Slave, IDE Channel 2 Master/Slave

Click <Enter> key to enter its submenu:

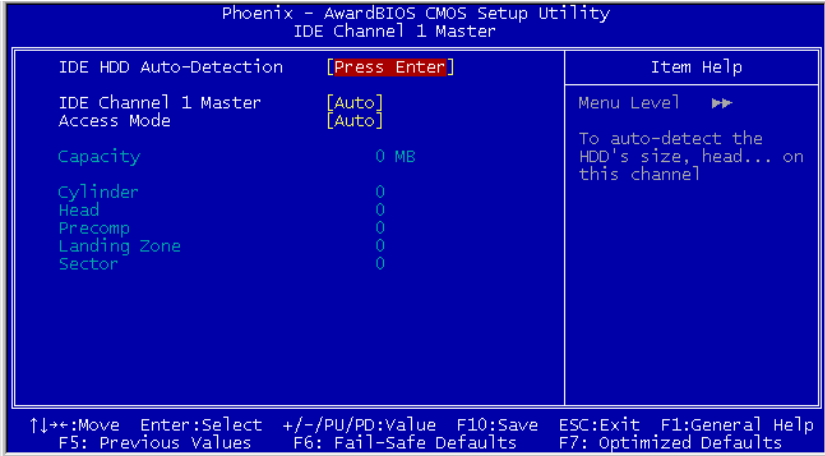

IDE HDD Auto-Detection

This item allows you to detect the parameters of IDE drives by pressing the <Enter> key. The parameters will automatically be shown on the screen.

IDE Primary Master

When set to [Auto], the BIOS will automatically check what kind of IDE drive you are using. If you want to define your own drive by yourself, set it to [Manual] and make sure you fully understand the meaning of the parameters. Refer to the manual provided by the device manufacturer to get the settings right.

Access Mode

This item selects the mode to access your IDE devices. Leave this item to its default [Auto] settings to let BIOS detects the access mode of your HDD and makes decision automatically.

✱ **Capacity**

This item automatically displays your HDD size. Note that this size is usually slightly greater than the size given by a disk-checking program of a formatted disk.

NOTE: The following [Cylinder], [Head], [Precomp], [Landing Zone], and [Sector] items are available when you set the item "IDE Primary Master" to "Manual".

*** Cylinder**

This item configures the numbers of cylinders.

*** Head**

This item configures the numbers of read/write heads.

*** Precomp**

This item displays the number of cylinders at which to change the write timing.

*** Landing Zone**

This item displays the number of cylinders specified as the landing zone for the read/write heads.

*** Sector**

This item configures the numbers of sectors per track.

Drive A

This item sets the type of floppy drives installed.

[None]: No floppy drive installed

[360K, 5.25 in.]: 5.25-inch standard drive; 360KB capacity

[1.2M, 5.25 in.]: 5.25-inch AT-type high-density drive; 1.2MB capacity

[720K, 3.5 in.]: 3.5-inch double-sided drive; 720KB capacity

[1.44M, 3.5 in.]: 3.5-inch double-sided drive; 1.44MB capacity

[2.88M, 3.5 in.]: 3.5-inch double-sided drive; 2.88MB capacity

Video

This item selects the type of video adapter used for the primary system monitor.

[EGA/VGA]: (Enhanced Graphics Adapter/Video Graphics Array) For EGA, VGA, SVGA and PGA monitor adapters.

[CGA 40]: (Color Graphics Adapter) Power up in 40-column mode.

[CGA 80]: (Color Graphics Adapter) Power up in 80-column mode.

[Mono]: (Monochrome adapter) Includes high-resolution monochrome adapters.

Halt On

This item determines whether the system stops if an error is detected during system boot-up.

[All Errors]: The system-boot will stop whenever the BIOS detect a non-fatal error.

[No Errors]: The system-boot will not stop for any error detected.

[All, But Keyboard]: The system-boot will stop for all errors but keyboard error.

[All, But Diskette]: The system-boot will stop for all errors but disk error.

[All, But Disk/Key]: The system boot will stop for all errors but disk or keyboard error.

Base Memory

This item displays the amount of base memory installed in the system. The value of the base memory is typically 640K for system with 640K or more memory size installed on the motherboard.

Extended Memory

This item displays the amount of extended memory detected during system boot-up.

Total Memory

This item displays the total memory available in the system.

3.2. Advanced BIOS Features

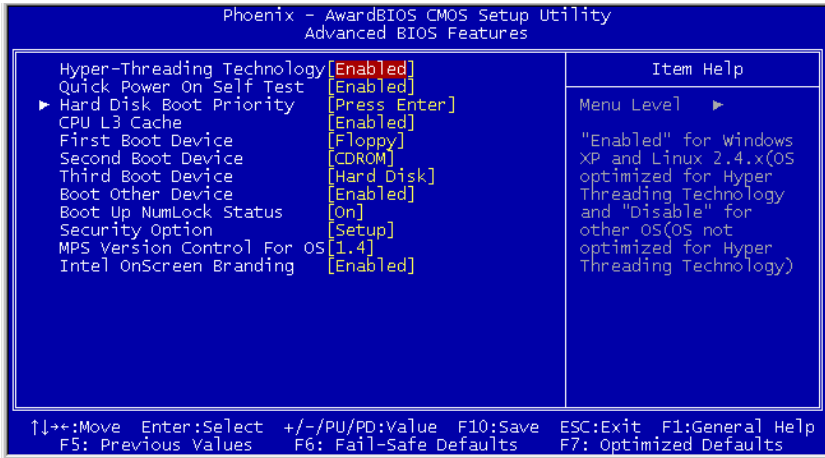

Hyper-Threading Technology

This item is used to enable the functionality of the processor with Hyper-Threading Technology and will appear only when using such processor.

The Hyper-Threading Technology helps your PC work more efficiently by maximizing processor resources and enabling a single processor to run two separate threads of software simultaneously, bringing forth greater performance and system responsiveness when running multiple applications at once.

Quick Power On Self Test

When set to [Enabled], this item speeds up the Power On Self Test (POST) after powering on the system. The BIOS shorten or skip some check during the POST.

Hard Disk Boot Priority

This item selects the hard disks booting priority. By pressing <Enter> key, you can enter its submenu where the hard disks detected can be selected for the booting sequence to boot up system.

This item functions only when there is the option of [Hard Disk] in any one of the First/Second/Third Boot Device items.

CPU L3 Cache

This item is used to enable the L3 cache (default setting), and appears only for certain CPU (Intel Pentium 4 processor with HT Technology Extreme Edition) that possesses L3 cache.

First Boot Device / Second Boot Device / Third Boot Device / Boot Other Device

This item selects the drive to boot first, second and third in the [First Boot Device], [Second Boot Device], and [Third Boot Device] fields respectively. The BIOS will boot the operating system according to the sequence of the drive selected. Set [Boot Other Device] to [Enabled] if you wish to boot from another device other than these three items.

Boot Up NumLock Status

This item determines the default state of the numeric keypad at system booting up.

[On]: The numeric keypad functions as number keys.

[Off]: The numeric keypad functions as arrow keys.

Security Option

This item determines when the system will prompt for password - every time the system boots or only when enters the BIOS setup.

[Setup]: The password is required only when accessing the BIOS Setup.

[System]: The password is required each time the computer boots up.

NOTE: Don't forget your password. If you forget the password, you will have to open the computer case and clear all information in the CMOS before you can start up the system. But by doing this, you will have to reset all previously set options.

MPS Version Control For OS

This item specifies which version of MPS (Multi-Processor Specification) this motherboard will use. Leave this item to its default setting.

Intel OnScreen Branding

This item determines whether to display the "Intel Inside" logo or not at system boots up.

3.3. Advanced Chipset Features

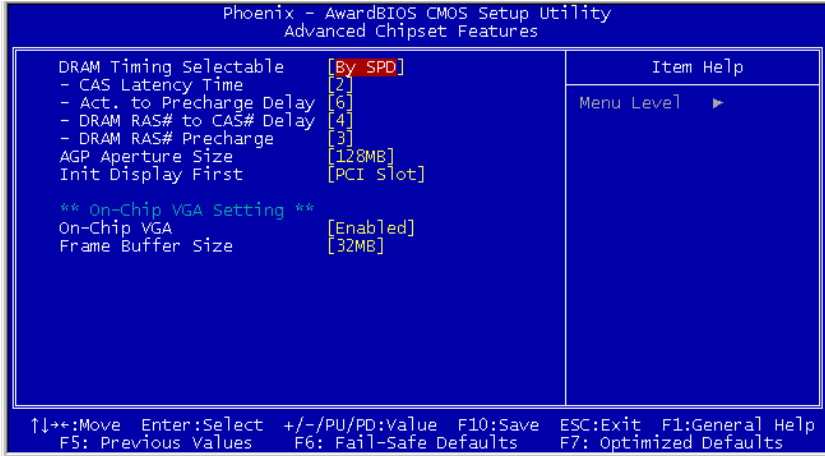

DRAM Timing Selectable

This item sets the optimal timings for the following four items, depending on the memory module you are using. The default setting “By SPD” configures these four items by reading the contents in the SPD (Serial Presence Detect) device. The EEPROM on the memory module stores critical parameter information about the module, such as memory type, size, speed, voltage interface, and module banks.

* CAS Latency Time

This item controls the latency between the DRAM read command and the time that the data becomes actually available.

* Act. to Precharge Delay

This item controls the number of DRAM clocks used for the DRAM parameters.

* DRAM RAS# to CAS# Delay

This item controls the latency between the DRAM active command and the read/write command.

* DRAM RAS# Precharge

This item controls the idle clocks after issuing a precharge command to the DRAM.

AGP Aperture Size

This option specifies the amount of system memory that can be used by the AGP device. The aperture is a portion of the PCI memory address range dedicated for graphics memory address space.

Init Display First

This item selects to initialize Onboard/AGP or PCI Slot first when the system boots.

On-Chip VGA

This option enables or disables the on-chip VGA controller.

Frame Buffer Size

This option selects the size of on-chip frame buffer.

3.4. Integrated Peripherals

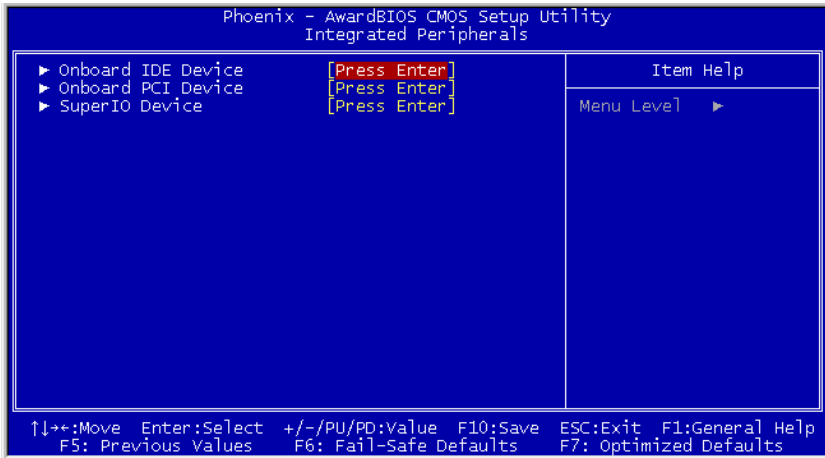

↩ Onboard IDE Device:

Click <Enter> key to enter its submenu:

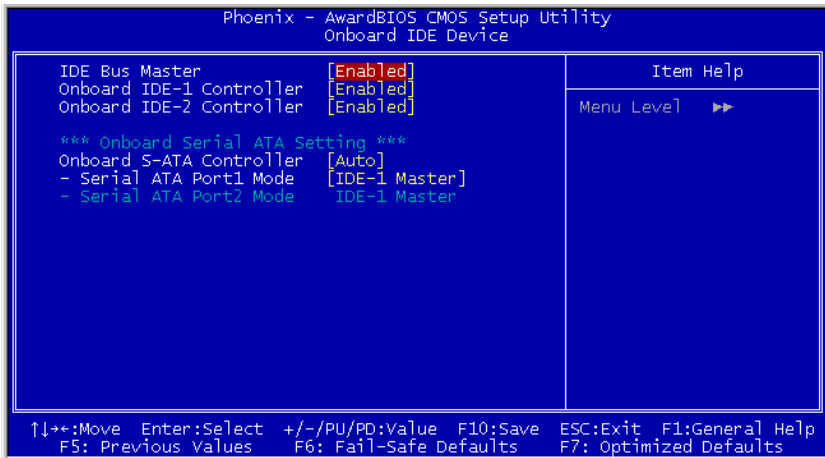

IDE Bus Master

This option enables or disables the IDE bus mastering capability under the DOS environment.

Onboard IDE-1 Controller

This item enables or disables the onboard IDE-1 controller.

Onboard IDE-2 Controller

This item enables or disables the onboard IDE-2 controller.

Onboard S-ATA Controller

This item determines the function for on-chip Serial ATA.

[Disabled]: Disable the Serial ATA controller.

[Auto]: Allows the Serial ATA controller to be arranged by BIOS automatically.

[Combined Mode]: Parallel ATA and Serial ATA are combined together. Supports up to 2 IDE drives in each channel.

[Enhanced Mode]: Enable both Parallel ATA and Serial ATA. Supports up to 6 IDE drives.

[SATA Only]: The SATA is operating in legacy mode.

※ **Serial ATA Port1 Mode / Serial ATA Port2 Mode**

This item determines the function mode for Serial ATA Port 1 (i.e. The SATA1 connector in this model) and Serial ATA Port 2 (i.e. The SATA2 connector in this model). Both SATA1 and SATA2 will be served each as one single IDE connector after selected as the following modes:

Mode	Serial ATA Port 1 (SATA1)	Serial ATA Port 2 (SATA2)	Description
Enhanced	IDE-3 Master	IDE-4 Master	<ul style="list-style-type: none"> • SATA1 serves as IDE-3 Master • SATA2 serves as IDE-4 Master • OnChip IDE-1 and IDE-2 controller enabled
	IDE-4 Master	IDE-3 Master	<ul style="list-style-type: none"> • SATA1 serves as IDE-4 Master • SATA2 serves as IDE-3 Master • OnChip IDE-1 and IDE-2 controller enabled
Combined	IDE-1 Master	IDE-1 Slave	<ul style="list-style-type: none"> • SATA1 serves as IDE-1 Master • SATA2 serves as IDE-1 Slave • OnChip IDE-1 controller disabled
	IDE-1 Slave	IDE-1 Master	<ul style="list-style-type: none"> • SATA1 serves as IDE-1 Slave • SATA2 serves as IDE-1 Master • OnChip IDE-1 controller disabled
	IDE-2 Master	IDE-2 Slave	<ul style="list-style-type: none"> • SATA1 serves as IDE-2 Master • SATA2 serves as IDE-2 Slave • OnChip IDE-2 controller disabled
	IDE-2 Slave	IDE-2 Master	<ul style="list-style-type: none"> • SATA1 serves as IDE-2 Slave • SATA2 serves as IDE-2 Master • OnChip IDE-2 controller disabled
SATA Only	Logical IDE-1	Logical IDE-2	<ul style="list-style-type: none"> • SATA1 serves as IDE-1 Master • SATA2 serves as IDE-2 Master • OnChip IDE-1 and IDE-2 controller disabled
	Logical IDE-2	Logical IDE-1	<ul style="list-style-type: none"> • SATA1 serves as IDE-2 Master • SATA2 serves as IDE-1 Master • OnChip IDE-1 and IDE-2 controller disabled

↶ **Onboard PCI Device:**

Click <Enter> key to enter its submenu:

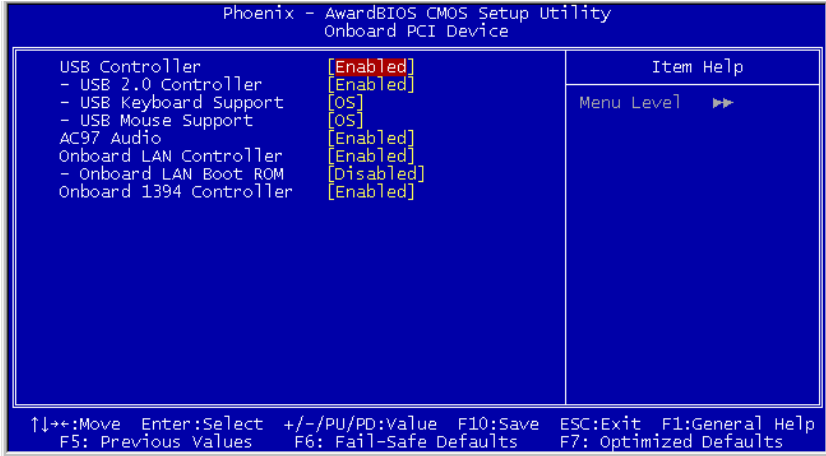

USB Controller

This option enables or disables the USB controller.

✱ **USB 2.0 Controller**

This option enables or disables the USB 2.0 controller.

✱ **USB Keyboard Support**

This item allows you to select [BIOS] for using USB keyboard in DOS environment, or [OS] in OS environment.

✱ **USB Mouse Support**

This item allows you to select [BIOS] for using USB mouse in DOS environment, or [OS] in OS environment.

AC97 Audio

When set to [Enabled], the onboard audio codec will be detected and supported. If you want to use audio adapter other than the one onboard, set this item to [Disabled]

Onboard LAN Controller

This item enables or disables the onboard LAN controller.

* Onboard LAN Boot ROM

When set to [Enabled], this item allows the system to boot from network by the onboard LAN controller boot ROM.

Onboard 1394 Controller (IS-12)

This item enables or disables the onboard IEEE 1394 controller.

↩ SuperIO Device:

Click <Enter> key to enter its submenu:

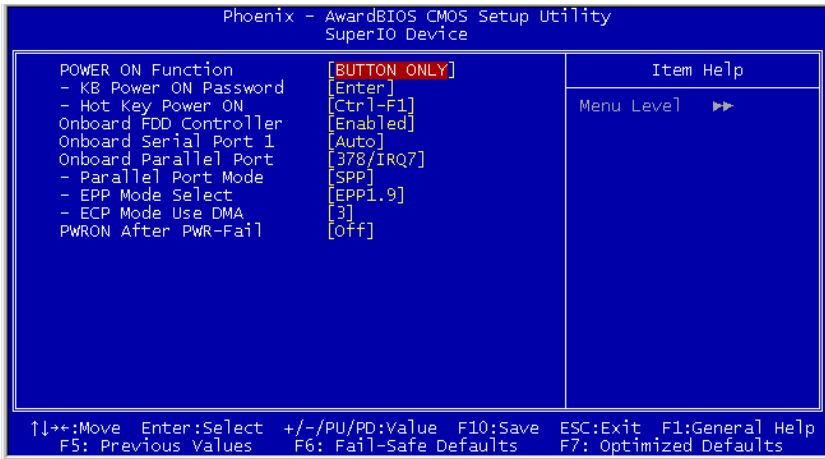

POWER ON Function

This item selects the way you want your system to power on.

[Password]: Use a password to power on the system, select this option then press <Enter>. Enter your password. You can enter up to 5 characters. Type in exactly the same password to confirm, and then press <Enter>.

[Hot KEY]: Use any of the function keys between <F1> to <F12> to power on the system.

[Mouse Left]: Double click the mouse left button to power on the system.

[Mouse Right]: Double click the mouse right button to power on the system.

[Any KEY]: Use any keyboard keys to power on the system.

[BUTTON ONLY]: Use only the power button to power on the system.

[Keyboard 98]: Use the power-on button on the “Keyboard 98” compatible keyboard to power on the system.

NOTE: The mouse wake up function can only be used with the PS/2 mouse, not with the COM port or USB type. Some PS/2 mice cannot wake up the system because of compatible problems. If the specs of your keyboard are too old, it may fail to power on.

✱ **KB Power ON Password**

This item sets the password required in order to power on your computer.

NOTE: Do not forget your password, or you will have to clear the CMOS and reset all parameters in order to utilize this function again.

✱ **Hot Key Power ON**

This item powers on the system by pressing <Ctrl> key plus one of each function key (<F1> ~ <F12>) simultaneously.

Onboard FDD Controller

This item enables or disables the onboard FDD controller.

Onboard Serial Port 1

This item determines which I/O addresses the onboard Serial Port 1 controller will access.

[Auto]: The system automatically select an I/O address for the onboard Serial Port 1.

[3F8/IRQ4, 2F8/IRQ3, 3E8/IRQ4, 2E8/IRQ3]: Allows you to manually select an I/O address for the onboard Serial Port 1.

[Disabled]: Disables the onboard Serial Port 1.

Onboard Parallel Port

This item specifies the I/O address used by the parallel port.

[Disabled]: This option prevents the parallel port from accessing any system resources. When the value of this option is set to [Disabled], the printer port becomes unavailable.

[378/IRQ7]: This option allows the parallel port to use [378/IRQ7] as its I/O port address. The majority of parallel ports on computer systems use IRQ7 and I/O Port 378H as the standard setting.

[278/IRQ5]: This option allows the parallel port to use [278/IRQ5] as its I/O port address.

[3BC/IRQ7]: This option allows the parallel port to use [3BC/IRQ7] as its I/O port address.

✱ **Parallel Port Mode**

This item specifies the parallel port mode.

[SPP]: (Standard Parallel Port) Allows bi-directional parallel port operation at normal speed.

[EPP]: (Enhanced Parallel Port) Allows bi-directional parallel port operation at maximum speed.

[ECP]: (Extended Capabilities Port) Allows bi-directional parallel port operation at a speed faster than the normal mode's data transfer rate.

[EPP+ECP]: Using parallel port as EPP & ECP mode.

✱ **EPP Mode Select**

This item selects the EPP mode.

✱ **ECP Mode Use DMA**

This item selects the DMA channel of the parallel port.

PWRON After PWR-Fail

This item sets the system action after a power failure.

3.5. Power Management Setup

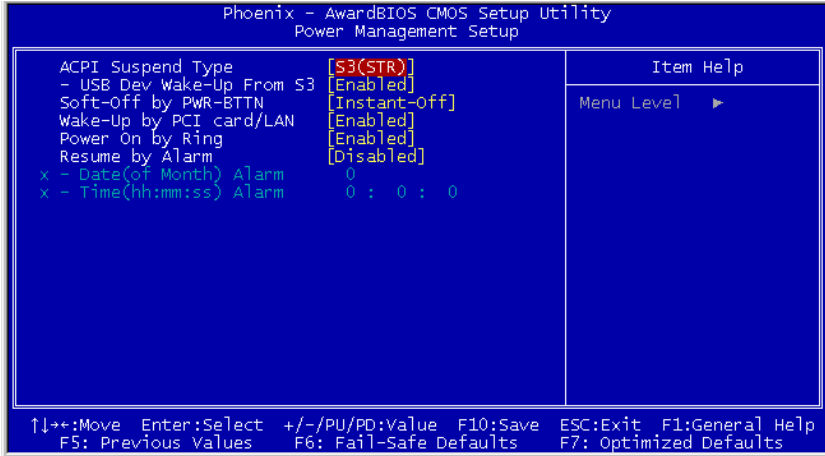

ACPI Suspend Type

This item selects the type of Suspend mode.

[S1(POS)]: Enables the Power On Suspend function.

[S3(STR)]: Enables the Suspend to RAM function.

* USB Dev Wake-Up From S3

When set to [Enabled], this item allows you to use a USB device to wake up a system that is in the S3 (STR - Suspend To RAM) state. This item can only be configured if the [ACPI Suspend Type] field is set to [S3(STR)].

Soft-Off by PWR-BTTN

This item selects the method of powering off your system:

[Hold 4 Sec.]: Pushing the power button for more than 4 seconds will power off the system. This will prevent the system from powering off in case you accidentally hit or pushed the power button.

[Instant-Off]: Pressing and then releasing the power button at once will immediately power off the system.

Wake-Up by PCI card/LAN

When set to [Enabled], access to the onboard LAN or a PCI card such as a modem or LAN card will cause the system to wake up. The PCI card must support the wake up function.

Power On by Ring

Two options are available: Enabled and Disabled. Default setting is *Disabled*. If you connect an external modem to the onboard serial port, the system will be turned on when a telephone ring-up occurs.

Resume by Alarm

When set to [Enabled], you can set the date and time you would like the Soft-Off PC to power-on in the “Date (of Month) Alarm” and “Time (hh:mm:ss) Alarm” items. However, if the system is being accessed by incoming calls or the network (Resume On Ring/LAN) prior to the date and time set in these items, the system will give priority to the incoming calls or network instead.

*** Date (of Month)**

[0]: This option power-on the system everyday according to the time set in the “Time (hh:mm:ss) Alarm” item.

[1-31]: This option selects a date you would like the system to power-on. The system will power-on on the date set, and the time set in the “Time (hh:mm:ss) Alarm” item.

*** Resume Time (hh:mm:ss)**

This item sets the time you would like the system to power-on.

3.6. PnP/PCI Configurations

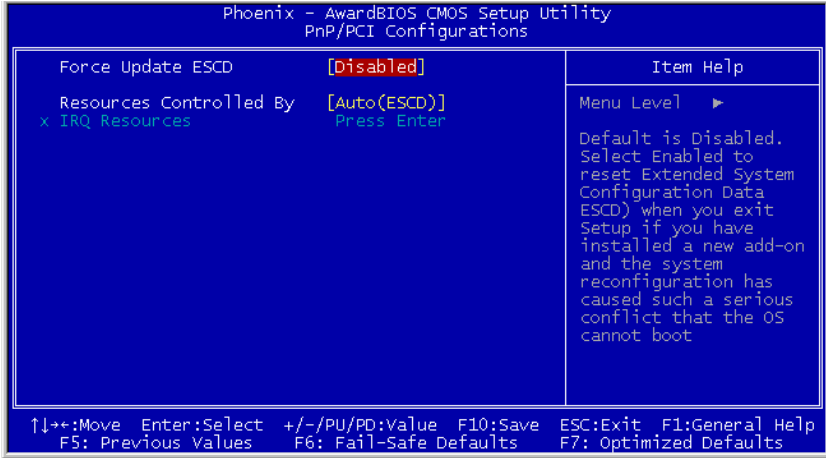

Force Update ESCD

If you want to clear ESCD data next time you boot up, and ask the BIOS to reset the settings for the Plug & Play ISA Card and the PCI Card, select Enabled. But the next time you boot up, this option will automatically be set as Disabled.

NOTE: The ESCD (Extended System Configuration Data) contains the IRQ, DMA, I/O port, memory information of the system. This is a specification and a feature specific to the Plug & Play BIOS.

Resources Controlled By

This item configures all of the boot and Plug-and-Play compatible devices.

[Auto(ESCD)]: The system will automatically detect the settings.

[Manual]: Choose the specific IRQ resources in the “IRQ Resources” menu.

IRQ Resources

Click <Enter> key to enter its submenu:

This item sets each system interrupt to either [PCI Device] or [Reserved].

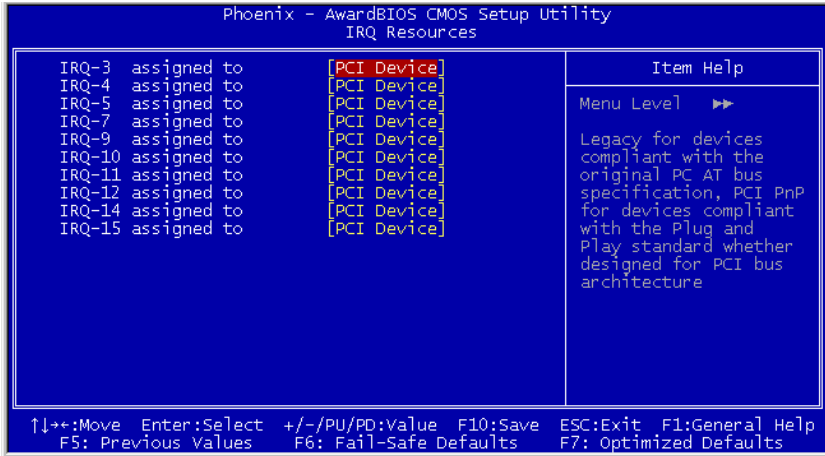

3.7. PC Health Status

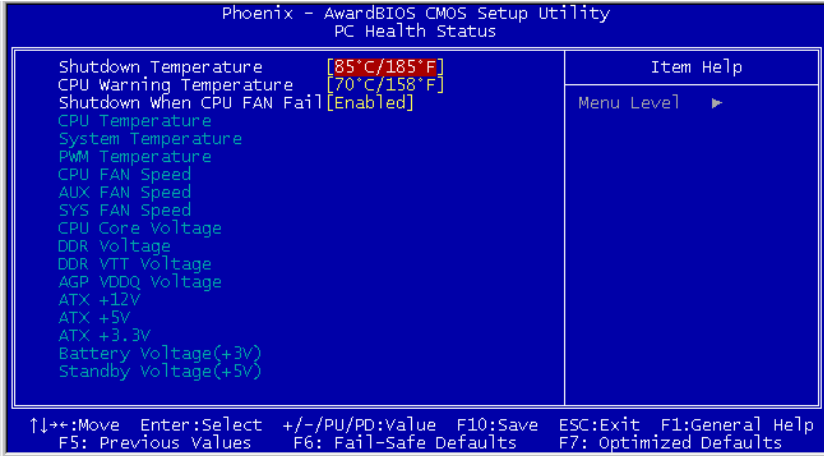

Shutdown Temperature

This item sets the temperature that would shutdown the system automatically in order to prevent system overheats.

CPU Warning Temperature

This item selects the CPU's warning temperature limit. Once the system has detected that the CPU's temperature exceeded the limit, warning beeps will sound.

NOTE: The onboard hardware monitor function is capable of detecting these system health conditions. If you want a warning message to pop-up or a warning alarm to sound when an abnormal condition occurs, you must install the "Hardware Doctor" utility. This utility is included in the "Driver & Utility CD" that came packed with this motherboard.

Shutdown When CPU FAN Fail:

When set to [Enabled], the system will be shut down if the CPU fan is not running.

All Voltages, Fans Speed and Thermal Monitoring

These unchangeable items list the current status of the CPU and environment temperatures, fan speeds, and system power voltage.

NOTE: The hardware monitoring features for temperatures, fans and voltages will occupy the I/O address from 294H to 297H. If you have a network adapter, sound card or other add-on cards that might use those I/O addresses, please adjust your add-on card I/O address to avoid using these addresses.

3.8. Load Fail-Safe Defaults

This option loads the BIOS default values for the most stable, minimal-performance system operations.

3.9. Load Optimized Defaults

This option loads the BIOS default values that are factory settings for optimal-performance system operations.

3.10. Set Supervisor Password

This option protects the BIOS configuration or restricts access to the computer itself. The Supervisor Password is used to protect the stored CMOS options from being changed by unauthorized users.

3.11. Set User Password

This option protects the BIOS configuration or restricts access to the computer itself. The User Password requires all users to enter a password in order to use the system, and/or enter the BIOS setup (but can't change its contents).

3.12. Save & Exit Setup

This option saves your selections and exits the setup menu.

3.13. Exit Without Saving

This option exits the setup menu without saving any change.

Chapter 4. Driver Installation

All the necessary drivers are included within the Drivers & Utilities CD that came packaged with your board. The display shown in the following figure should appear after inserting this CD into your CD-ROM drive, if not, enter → [My Computer] → [CD-ROM] Drive → double click [autorun.exe]. Please follow the on-screen instruction.



4.1. Setup Items

- **Intel Chipset Software Utility**
Install the Intel chipset driver for Windows Operating System.
- **Intel Extreme Graphics Driver**
Install Intel graphics adapter driver for Windows Operating System.
- **Audio Driver**
Install the audio driver for Windows Operating System.
- **LAN Driver**
Install the LAN driver for Windows Operating System.
- **USB 2.0 Driver**
Install the USB 2.0 driver for Windows Operating System.
- **Manual**
View the user's manual in PDF file.
- **Utility**
Click to enter the sub-screen for installing DirectX, Acrobat Reader, and Award Flash utility software.
- **Browse CD**
Browse the contents of this CD-ROM.
- **Close**
Exit the CD setup Items Menu.

Appendix A. How to Get Technical Support

(From our website) <http://www.abit.com.tw>

(In North America) <http://www.abit-usa.com>

(In Europe) <http://www.abit.nl>

Thank you for choosing ABIT products. ABIT sells all our products through distributors, resellers and system integrators; we have no direct sales to end-users. Before sending email for tech support please check with your resellers or integrators if you need any services, they are the ones who sold you your system and they should know best as to what can be done, how they serve you is a good reference for future purchases.

We appreciate every customer and would like to provide the best service to you. Providing fast service to our customers is our top priority. However we receive many phone calls and a huge amount of email from all over the world. At the present time it is impossible for us to respond to every single inquiry. Therefore it is quite possible that if you send an email to us that you may not receive a response.

We have done many compatibility tests and reliability tests to make sure our products have the best quality and compatibility. In case you need service or technical support, please understand the constraint we have and **always check with the reseller who sold the product to you first.**

To expedite service, we recommend that you follow the procedures outlined below before contacting us. With your help, we can meet our commitment to provide the best service to the **greatest number of ABIT customers:**

- 1. Check the Manual.** It sounds simple but we have taken a lot of care in making a well-written and thorough manual. It is full of information that doesn't only pertain to motherboards. The CD-ROM included with your board will have the manual as well as drivers. If you don't have either one, go to our Program Download Area of the Website or FTP server.
- 2. Download latest BIOS, software or drivers.** Please go to our Program Download area on our Website to check to see if you have the latest BIOS. They are developed over periods of time to fix bugs or incompatibilities. **Also please make sure you have the latest drivers from your peripheral cards makers!**
- 3. Check the ABIT Technical Terms Guide and FAQ on our Website.** We are trying to expand and make the FAQs more helpful and information rich. Let us know if you have any suggestions. For hot topics check out our HOT FAQ!

- 4. Internet Newsgroups.** They are a great source of information and many people there can offer help. ABIT's Internet News group, alt.comp.periphs.mainboard.abit, is an ideal forum for the public to exchange information and discuss experiences they have had with ABIT products. Many times you will see that your question has already been asked before. This is a public Internet news group and it is reserved for free discussions. Here is a list of some of the more popular ones:

alt.comp.periphs.mainboard.abit

comp.sys.ibm.pc.hardware.chips

alt.comp.hardware.overclocking

alt.comp.hardware.homebuilt

alt.comp.hardware.pc-homebuilt

- 5. Ask your reseller.** Your ABIT authorized distributor should be able to provide the fastest solution to your technical problem. We sell our products through distributors who sell to resellers and stores. Your reseller should be very familiar with your system configuration and should be able to solve your problem much more efficiently than we could. After all, your reseller regards you as an important customer who may purchase more products and who can urge your friends to buy from him or her as well. They integrated and sold the system to you. They should know best what your system configuration is and your problem. They should have reasonable return or refund policies. How they serve you is also a good reference for your next purchase.
- 6. Contacting ABIT.** If you feel that you need to contact ABIT directly you can send email to the ABIT technical support department. First, please contact the support team for the branch office closest to you. They will be more familiar with local conditions and problems and will have better insight as to which resellers offer what products and services. Due to the huge number of emails coming in every day and other reasons, such as the time required for problem reproduction, we will not be able to reply to every email. Please understand that we are selling through distribution channels and don't have the resources to serve every end-user. However, we will try to do our best to help every customer. Please also remember that for many of our technical support team English is a second language, you will have a better chance of getting a helpful answer if your question can be understood in the first place. Be sure to use very, simple, concise language that clearly states the problem, avoid rambling or flowery language and always list your system components. Here is the contact information for our branch offices:

North America and South America:

ABIT Computer (U.S.A.) Corporation

45531 Northport Loop West,
Fremont, California 94538, U.S.A.

Tel: 1-510-623-0500

Fax: 1-510-623-1092

sales@abit-usa.com

technical@abit-usa.com

<http://www.abit-usa.com>

U.K. and Ireland:

ABIT Computer (U.K.) Corporation Ltd.

Unit 3, 24-26 Boulton Road,
Stevenage, Herts SG1 4QX, U.K.

Tel: 44-1438-228888

Fax: 44-1438-226333

sales@abitcomputer.co.uk

technical@abitcomputer.co.uk

***Germany, Benelux (Belgium, Netherlands, Luxembourg),
Denmark, Norway, Sweden, Finland, and Switzerland:***

AMOR Computer B.V. (ABIT's European Office)

Van Coehoornstraat 7,
5916 PH Venlo, The Netherlands

Tel: 31-77-3204428

Fax: 31-77-3204420

sales@abit.nl

technical@abit.nl

<http://www.abit.nl>

***Austria, Czech, Romania, Bulgaria, Yugoslavia, Slovakia,
Slovenia, Croatia, Bosnia, Serbia, and Macedonia:***

Asguard Computer Ges.m.b.H

Schmalbachstrasse 5,
A-2201 Gerasdorf/Wien, Austria

Tel: 43-1-7346709

Fax: 43-1-7346713

asguard@asguard.at

Japan:

ABIT Computer (Japan) Co. Ltd.

Fax: 81-3-5396-5110

<http://www.abit4u.jp>

Shanghai:

ABIT Computer (Shanghai) Co. Ltd.

Tel: 86-21-6235-1829

Fax: 86-21-6235-1832

<http://www.abit.com.cn>

Russia:

ABIT Computer (Russia) Co. Ltd.

Fax: 7-095-937-2837

techrussia@abit.com.tw

<http://www.abit.ru>

France, Italy, Spain, Portugal, and Greece:

ABIT Computer France SARL

Tel: 33-1-5858-0043

Fax: 33-1-5858-0047

<http://www.abit.fr>

***All other territories not covered above please contact
Taiwan Head Office:***

When contacting our headquarters please Note we are located in Taiwan and we are 8+ GMT time. In addition, we have holidays that may be different from those in your country.

ABIT Computer Corporation

No.323, Yang Guang St., Neihu,

Taipei, 114, Taiwan

Tel: 886-2-8751-8888

Fax: 886-2-8751-3382

server_sales@abit.com.tw

market@abit.com.tw

technical@abit.com.tw

<http://www.abit.com.tw>

7. **RMA Service.** If your system has been working but it just stopped, but you have not installed any new software or hardware recently, it is likely that you have a defective component. Please contact the reseller from whom you bought the product. You should be able to get RMA service there.
8. **Reporting Compatibility Problems to ABIT.** Because of tremendous number of email messages we receive every day, we are forced to give greater weight to certain types of messages than to others. For this reason, any compatibility problem that is reported to us, giving detailed system configuration information and error symptoms will receive the highest priority. For the other questions, we regret that we may not be able to reply directly. But your questions may be posted to the Internet news group in order that a larger number of users can have the benefit of the information. Please check the news group from time to time.

Thank You

ABIT Computer Corporation

<http://www.abit.com.tw>



Technical Support Form

Company Name:

Phone Number:

Contact Person:

Fax Number:

E-mail Address:

Model	*	BIOS ID #	*
Motherboard Model No.		DRIVER REV	
OS/Application	*		
Hardware Name	Brand	Specifications	
CPU	*		
HDD	<input type="checkbox"/> IDE1 <input type="checkbox"/> IDE2		
CD-ROM-Drive	<input type="checkbox"/> IDE1 <input type="checkbox"/> IDE2		
System Memory			
ADD-ON CARD			

Problem Description:

