



MUSTANG
COMMUNICATIONS

MACRO SYSTEM AMPLIFICATION

INSTALLATION, COMMISSIONING & MAINTENANCE HANDBOOK

Issue No.6

SCOPE OF THIS ISSUE:

M/8M	M8/M
M1008	M1008/D
M2508	M2508/D
M100/S	M100/SD
M250/S	M250/SD

Input modules
Standard options

Mustang Communications Ltd
Eastfield Industrial Estate
Scarborough
England
YO11 3UT

Telephone U.K. 01723 582 555
Telephone International 44 1723 582 555

Fax U.K. 01723 581 673
Fax international 44 1723 581 673

Email info@mustang.co.uk
Web www.mustang.co.uk

Author: M. R. Tetley M. Inst. S. C. E.

INDEX

.....	page
Introduction	5
- The Company and its quality statement	5
- The MACRO system concept and applications	5
General specifications	6
Front panel controls and indicators	6
Tone control & Master gain adjustment	6
Input module system	7
- module installation	7
- module range	7
- features & general specifications	8
- input connections	9
- module adjustments	10
Priority input facilities	10
- priority/passive setting of modules	12
- priority memory	12
Pre-announcement chimes	12
Mixer facility connections - 0dB signal access point	12
- 0dB signal in/out access for mixers & mixer amplifiers	12
- input connections for slave amplifiers	12
- tape recording	13
- tape playback	13
- interconnection of several amplifiers	13
Power amplifier module	14
Loudspeaker output	14
- typical loudspeaker load arrangements	15
Auxiliary output connections	16
- Priority controlled DC current sinks	16
- Chime duration monitor sinks (CDM)	16
- 100V line output	16
- 24V DC supply	16
Combining the loudspeaker outputs of two or more amplifiers	17
Power supply	17
- AC mains power input	17
- DC power input	17
- Systems powered by both AC and DC supplies	17
- Main ON-OFF front panel switch	17
- Error status indicator LED	19
- Power status indicator LED	19
- Power supply failure monitoring	19
- Power supply change-over	20
- Battery charger circuit	20
Earthing & hum loops	20
Factory fitted options	20
- Free-standing case	20
- Automatic level control	21
- Balanced line input for M/100 and M/250 slave amplifiers	21
- Line surveillance	22
Installation	22
- selection of signal input cables	22
- selection of loudspeaker cable	22
- fitting Locking DIN connectors	22
- siting	23
- ventilation	23
- interference	23
- removal of control knobs	23
- checklist	23
Fuses	24
Faults - symptoms and check-list	24
Repairs and maintenance	24
- free-standing case removal	24
- removal of main pre-amplifier circuit board	24
Warranty	24

 Electromagnetic compatibility (EMC) directive 89/336/EEC and amendment directive 92/31/EEC
 This equipment has been designed and manufactured to the highest standards. If connected and operated as set out in this manual, there should be no Electromagnetic Compatibility problems. If any aspect of operation gives rise to concern, then please contact the manufacturer for advice.

	PAGE	
Table 1	The current range of input modules	8
Table 2	Module adjustments and settings	11
Fig. 1	Location of Treble, Bass, and Master gain controls	7
Fig. 2	Input connector pin identification	10
Fig. 3	Location of priority sequence setting switches	11
Fig. 4	Mixer facility connections for standard locking DIN connector	12
Fig. 5	Mixer facility connector pin identification	12
Fig. 6	Tape record and playback connections	13
Fig. 7	Interconnection of several amplifiers	14
Fig. 8	Power amplifier module fixings and adjustments	15
Fig. 9	Priority connections for multiple amplifier systems	18
Fig. 10	AC & DC supply connections and monitoring	19
Fig. 11	Balanced line input connections	21
Block schematic diagram		APPENDIX A
Typical priority control and auxiliary arrangements		APPENDIX B
Typical loudspeaker circuits		APPENDIX C
Chassis layout & main component identification		APPENDIX D
Locations of module adjustments and fuses		APPENDIX E

INTRODUCTION

Thank you for purchasing this unit. We are confident that you have made a wise decision, and that you will have many years of trouble-free operation. Considerable care has been taken during the design and manufacturing processes to ensure your entire satisfaction and naturally, we would hope that the unit will perform to our design expectations, though this will be possible only if the installation is in line with professionally accepted standards and techniques.

This manual is intended, therefore, to ensure that both the installer and operator have all the necessary information to enable them to install, commission, and operate the unit in the most effective manner. We hope you will find the manual helpful, and easy to read.

The Company and its quality statement

Mustang Communications, is the manufacturing mark of equipment manufactured by Mustang Communications Limited, of Scarborough, England. The company is independent, wholly British, and dedicated to the manufacture and distribution of high-reliability, high performance public address and associated control equipment. Mustang Communications was first registered in 1966, in England.

The Company undertakes to manufacture equipment to the highest standards of workmanship and performance. Our Quality Assurance scheme operates to, or exceeds, the standards set out in British Standard BS.5750, Part 2. 1987 or European standard ISO.9002. If you have cause to doubt at any time that the manufacture, or distribution does not comply, then you are invited to write to us with your comments, which will be most welcome.

Please address your correspondence to The Engineering Director.

The MACRO system concept and applications

MACRO System is a comprehensive range of AC mains and AC mains/24V DC amplification, controls and surveillance units and associated peripherals, designed for use by emergency services and high integrity communication and alarm systems, manufactured to the highest standards of electronic and mechanical performance and with Quality Assurance to British Standard BS.5750 AC/DC equipment is designed to operate normally from 220/240V AC mains, with the capability to operate indefinitely, and without loss of any facilities, from a standby DC power source (battery system) in the event of mains failure.

Full compatibility within the MACRO range is assured, thus easing system design and enabling fully integrated systems to be specified using standard MACRO components and options.

The current manufacturing programme features a variety of 8 input mixers, 100 Watt and 250 Watt 8 input mixer amplifiers and corresponding slave amplifiers, all offered in AC mains only or AC/DC format. AC/DC units provide full AC and DC power integrity monitoring and indication, and all except mixers feature a trickle-charge circuit as standard. Mixer input versions accommodate up to 8 modules, selected from the comprehensive range of microphone, line input and alarm tone generator modules. These are plugged into an internal mother board system which generates 8 levels of ladder priority, equal access priority or any combination of both. Priorities may be set up easily at system commissioning stage. The module circuits feature various aspects of memory trigger, priority sinking for use with MACRO zone controllers, remote relays, system busy indicators etc., and such functions are taken to a rear "D" connector. Each module is associated with a front panel gain control whose knob and spindle may be removed at commissioning stage and replaced by a discreet blanking plug to discourage unauthorised tampering. Line driver and stabilised low voltage PSU facilities are also on plug in modules. Treble and bass tone, and master gain adjustments are internal and pre-settable.

The amplifier power output stage is in the form of a self contained bolt-on pluggable module for ease of maintenance, and pre-set adjustment for sensitivity, overload threshold, and bias are featured. Output devices are very robust bipolars and errors on the module are notified by a front panel LED. Other front indicators are a segmented bargraph output VU, AC (and DC where appropriate) supply input monitoring, and an illuminated power switch. A soft-start DC switch on circuit is employed. The transformers employed in MACRO amplifiers are in-house designed and manufactured to the highest standards of tolerance and quality to maximise the efficiency of the electronics.

Mechanically, MACRO amplifiers utilise a 3U 19" rack mount format with plated steel chassis, contoured aluminium alloy anodised front/rear panels, chromed handles, nut and bolt fastenings, and connectors are tough locking DIN as standard for signals, "D" connector for auxiliary control functions, IEC mains, and military specification 97 series DC input.

By appropriate choice of input modules, the MACRO range of equipment will perform with outstanding results in a multitude of applications, and a few only are listed under:-

- Factory paging, time signals and alarm amplification
- Retail stores paging and background music
- Theatre show relay and prompt calls etc.
- Multi-zone exclusive paging using one amplifier
- Shopping centre automatic "spot announcements" and security paging etc.
- Zoned fire alarm systems

In use the amplifiers will give trouble free and accurate performance, and failure or partial failure is likely to be a result of external problems with loudspeaker or input cabling etc. The following pages will provide a guide to setting up, operation and maintenance of the amplifier, but in case of difficulty it would be advisable to consult a qualified dealer or the manufacturer.

GENERAL SPECIFICATIONS

MIXER AMPLIFIERS	M1008 M1008/D	M2508 M2508/D
Input channels	8	8
Input channel level & response	dependent upon input modules fitted	
Treble & Bass adjustment	± 12dB @ 100Hz & 10kHz ref.1kHz	
Power output (Watts RMS contin.)	100	250
Current sinks	250mA maximum, each channel module	
Auxiliary DC output	nominally +24V. 1A fused.	
Mixer facility level	775mV nominal. 0dBV	
Power amplifier input	775mV, 0dBV @ 10k ohms	
Power amplifier power freq. resp.	-3dB @ 20Hz & 20kHz ref. 1kHz, low imp -3dB @ 20Hz & 15kHz ref. 1kHz, 100V	
Loudspeaker matching	100V/50V line balanced	
AC mains supply input	240V 50-60Hz +5% -15%	
24V DC supply input (22-28V)	6 Amp	18 Amp
DC quiescent consumption (approx)	350mA	350mA
SLAVE AMPLIFIERS	M100 M100/D	M250 M250/D
Power output (Watts RMS contin.)	100	250
Audio input level	775mV, 0dBV @ 10k ohms	
Power amplifier power freq. resp.	-3dB @ 20Hz & 20kHz ref. 1kHz, low imp -3dB @ 20Hz & 15kHz ref. 1kHz, 100V	
Loudspeaker matching	100V/50V line balanced	
AC mains supply input	240V 50-60Hz +5% -15%	
24V DC supply input (22-28V)	6 Amp	18 Amp
DC Quiescent consumption (approx)	250mA	250mA
MIXERS	M8M	M8M/D
Input channels	8	8
Input level & response	dependent upon input modules fitted	
Treble & Bass adjustment	± 12dB @ 100Hz & 10kHz ref.1kHz	
Current sinks	250mA maximum, each channel module	
Auxiliary DC output	nominally +24V, fused 1A	
Audio output level	775mV nominal. 0dBV	
AC mains input	240V 50-60Hz +5% -15%	
24V DC supply input (22-28V)	—	250mA (module dependent)
DC quiescent consumption (approx)	—	150mA

FRONT PANEL CONTROLS & INDICATORS

By design, user accessible controls are kept to a minimum to avoid inadvertent maladjustment which could render the system ineffective.

Each input channel of a **MACRO** mixer or mixer-amplifier may be adjusted for gain by using the front panel controls. Should the commissioning engineer deem it prudent, he may remove any of the complete control knob/spindle assemblies, after adjustment is complete, simply by pulling the knob. The resulting holes may then be blanked off using the blanking plugs supplied. The controls may be refitted at any time subsequently. Slave amplifiers to standard specification are not fitted with a front gain control. An illuminated power switch controls AC power input (and if applicable, DC power input simultaneously).

A series of LED indicators provides a simple means of assuring the user of correct amplifier operation. A 10 segment ladder gives an indication of output level expressed in decibels - i.e. dB relative to maximum output amplitude. Under normal programme conditions this will fluctuate between the extreme left and extreme right segments in accordance with the amplitude of the programme at any particular instant. No segment is illuminated when the amplifier output is zero. If the illuminated segment is predominantly to the extreme right (maximum) then it is likely that the amplifier is being over-driven and that the resulting sound will be distorted on peaks. Reduce the corresponding front input gain control accordingly.

A fast attack/slow decay circuit is used to drive the display so that amplitude peaks are recognised.

Two further LEDs indicate the status of the power supply in use, and of the power amplifier module where appropriate. For further details see page 19.

tone control & MASTER GAIN ADJUSTMENT

Tone control facilities are provided on the line driver module, type TB.6 which is located at second right, on a mixer or mixer amplifier when viewed from the front. Two trimmer potentiometers are located at the bottom of the module, just above the edge connection tabs. Viewed from the front, the nearest is the bass adjustment and the furthest is the treble. Each controls a cut & lift correction circuit with the central position of the rotator giving nominally flat response. At the extremities of rotation, the corrections are ± 12dB at 100Hz and 10kHz respectively. Rotate controls clockwise to increase the gain at bass or treble frequencies. On

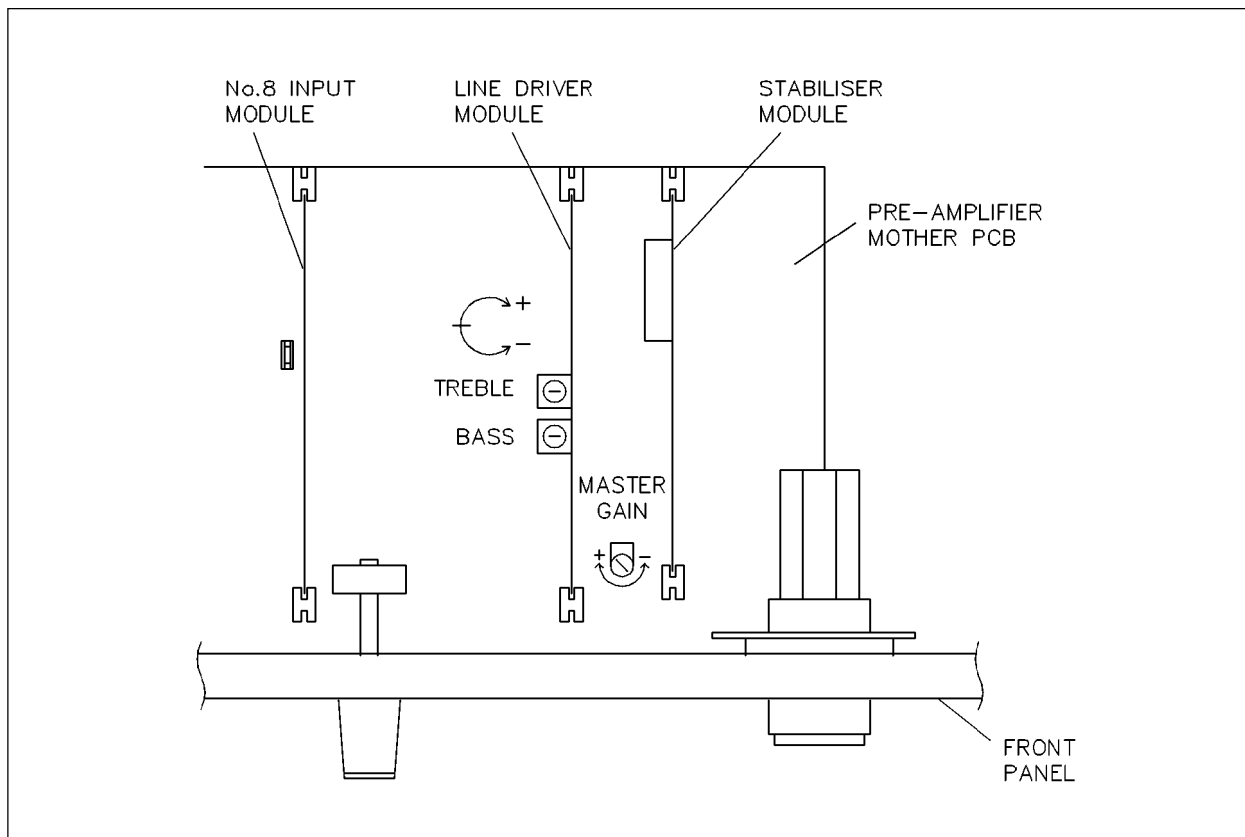

Fig. 1 Location of Treble, Bass, and Master gain controls

leaving the factory, the controls will be set for level response. See Fig. 1

A conventional master level control is featured on the mother PCB between the line driver module (TB.6 etc) and the pre-amplifier stabiliser module (PS.9 etc.) next to it. This control is set to maximum (fully clockwise) on leaving the factory. See Fig. 1

INPUT MODULE SYSTEM

The general accent of **MACRO** system amplification is towards flexibility of system design. Each **MACRO** mixer or mixer amplifier will accommodate up to 8 purpose designed input modules selected from over 30 variations of pre-amplifiers, tone signal and alarm generators. Any of the modules from the published list may be used in any of the 8 input channels of the amplifiers. Modules are available to accept audio input signals for low-level processing from all known audio sources. Depending on type, each module may be given a priority within the amplifier as described below. The chosen group of modules is set up within the amplifier by the commissioning engineer to exhibit the required sequence of priorities for the specific sound system, and further individually adjusted on the module for sensitivity, tone frequency, etc. These system adjustments are not directly accessible to the user, who is confined to the front panel controls. Modules may be changed, removed, or adjusted at any time without disturbance to the general operation of the system. Where priority sinking is featured, two alternative sinks are offered simultaneously - "Any" priority, and "Individual input" priority. Therefore, external circuits such as relays, lamps, **MACRO** zone control systems etc., may be triggered by any input channel or a specific input channel (or channels) by appropriate auxiliary connections. A "Chime Duration Monitor" circuit, where fitted, gives "clearance-to-speak" information for paging systems via the "CDM" current sink connection of the auxiliary output. Priority sinks and "CDM" current sinks operate independently of each other. The general concepts are illustrated in APPENDIX B

Module installation

MACRO range amplification is intended for permanent installation, and consequently the plug-in concept of the modules does not anticipate continuous or regular changing of modules. Whilst this is possible, the edge connector contacts may wear prematurely and become intermittent and unreliable. Modules are located between vertical supports immediately behind the respective front panel volume control, and only moderate force will be required when fitting or removing. DO NOT put pressure on the components during this operation.

Module range

The range of input modules extends to cover all common functions though others may be added to suit demand. The current range is shown below.

MICROPHONE & LINE INPUT MODULES	
M24	Universal low impedance transformer balanced, priority/passive
M26	Low imp. transformer balanced, with priority, chimes and CDM
M28	Low impedance transformer balanced, audio operated priority
M30	Low impedance transformer balanced, priority/passive, phantom DC
L24	600 ohm transformer balanced priority/passive, 50mV - .775V
L25	10k ohm transformer balanced priority/passive, 50mV - .775V
L26	47k ohm transformer balanced priority/passive, 50mV - 80V
L27	600 ohm transformer balanced, priority, chime, CDM. 50mV - .775V
L28	10k ohm transformer balanced, priority, chime, CDM. 50mV - .775V
L29	47k ohm transformer balanced, priority, chime, CDM 50mV - 80V
L30	600 ohm transformer bal., audio activated priority, 50mV - .775V
L31	10k ohm transformer bal., audio activated priority, 50mV - .775V
L32	47k ohm transformer bal., audio activated priority, 50mV - 80V
L33	Aux unbalanced line, 50mV & .775V, priority/passive
L34	Aux unbalanced line, 50mV & .775V, priority, chimes (no CDM)
NON-PRIORITY MODULES	
E26	RIAA equalised 5mV @ 50K for magnetic phono cartridge Flat response, 80mV to 1V for ceramic phone cartridge
TONE GENERATOR MODULES	
T24	1kHz sine wave generator, momentary triggering
T25	Time pips, with timer, priority hold & memory
T26	Repeating gongs with timer, priority hold & memory
T27	Alternating dee-dah alarm with timer, priority hold & memory
T28	Warble alarm with timer, priority hold & memory
T30	Trimphone telephone simulator, momentary triggering
T32	Triple chimes with timer, priority hold, & memory
T34	Slow whoop with timer & priority hold

Table 1 The current range of input modules

Module features & general specifications

MICROPHONE INPUT MODULES	M24	M26	M28	M30
Transformer or Electronic balanced	T	T	T	T
Priority only or priority/passive option	PP	PO	PO	PP
Priority controlled current sink	✓	✓	✓	✓
Chimes & Chime Duration Monitor sink		✓		
Phantom DC supply				✓
Audio activated priority (VOX)			✓	
Bass cut facility	✓	✓	✓	✓

GENERAL SPECIFICATIONS - MICROPHONE INPUT MODULES

Sensitivity range	100uV to 2mV
Input impedance	Suitable for 200 ohm microphones
Frequency response -3dB points	20Hz - 20kHz
Bass cut response	-3dB @ 200Hz -6dB @ 100Hz
Signal to noise ratio	58dB minimum
Input overload capability	50dB
Sink capability (mA max. continuous)	250mA
Phantom supply	+15V via 1k0
VOX delay	3 seconds maximum

LINE INPUT MODULES	L24	L25	L26	L27	L28	L29	L30	L31	L32	L33	L34
Transformer input or unbalanced	T	T	T	T	T	T	T	T	T	U	U
Priority operation only				✓	✓	✓	✓	✓	✓		
Priority/passive switchable	✓	✓	✓							✓	✓
Sensitivity 50mV - .775V	✓	✓		✓	✓		✓	✓		✓	✓
Sensitivity 50mV - 80V			✓			✓			✓		
Input impedance (ohms)	600	10k	47k	600	10k	47k	600	10k	47k	4k7	4k7
Priority controlled sink	✓	✓	✓	✓	✓	✓	✓	✓	✓	✓	✓
Chimes				✓	✓	✓	✓	✓	✓		✓
Chime Duration Sink				✓	✓	✓					
Audio activated priority (VOX)							✓	✓	✓		

GENERAL SPECIFICATIONS - LINE INPUT MODULES

Sensitivity range and impedance	See above
Frequency response -3dB points	20Hz - 18kHz
Signal to noise ratio	58dB minimum
Input overload capability	50dB
Sink capability (mA max. continuous)	250mA
VOX delay	3 seconds maximum

TONE GENERATORS	T24	T25	T26	T27	T28	T30	T31	T32	T34
Momentary or timed triggering	M	T	T	T	T	M	T	T	T
Adjustable tone frequency		✓	✓	✓	✓	✓	✓	✓	✓
Priority hold for tone sequence		✓	✓	✓	✓		✓	✓	✓
Priority memory		✓	✓	✓	✓		✓	✓	✓
Adjustable duration timer		✓	✓	✓	✓		✓	✓	✓

GENERAL SPECIFICATIONS - TONE GENERATOR MODULES

Trigger switch requirements	1.5mA maximum @ +15V DC
Duration timer	2 - 30 seconds approx
Trigger memory capacity	Indefinite
Sink capability (mA max. continuous)	250mA

MISCELLANEOUS MODULES	E26	
Function	Magnetic phono pre-amp	Ceramic phono pre-amp
Sensitivity	5mV@50k	80mV-1V @ 1M
Equalisation	RIAA	Flat

Input connections

Standard amplifiers are fitted with Locking 5 pin DIN input connectors on a 180 degree spacing pattern. See Fig. 2 below to identify the pin numbers. The input connections will vary depending upon which module is being used in the corresponding module position, as follows:

Balanced microphone & line input modules i.e. M24 to M30 and L24 to L32 inc.

Standard Locking 5 pin DIN -

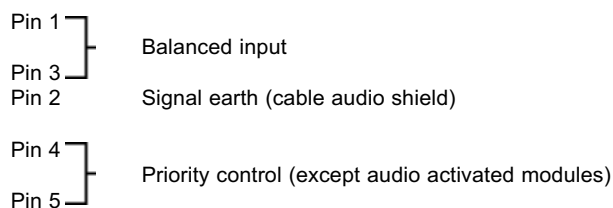

Auxiliary inputs and music modules i.e. L33, L34, E24, E25.

Standard Locking 5 pin DIN -

Pin 1	Signal input
Pin 2	Signal earth (cable audio shield)
Pin 3	Signal input
Pin 4	Priority control (except E24, E25, T35)
Pin 5	

Tone generator modules i.e. T24 to T34 inclusive

Standard Locking 5 pin DIN -

Pin 1	No connection
Pin 2	No connection
Pin 3	No connection
Pin 4	Priority control & tone trigger
Pin 5	

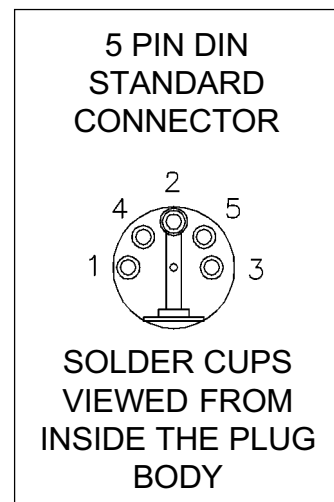

Fig. 2
Input connector pin identification

Locking 5 pin DIN connector plugs are not furnished automatically with the unit, and must be ordered as a separate item.

Module adjustments

Various adjustments are available on each module, dependent on type and function, etc and are shown in table 2. The general locations are shown in APPENDIX E.

PRIORITY INPUT FACILITIES

Each **MACRO** amplifier (with input module facilities) can be programmed to provide up to 8 levels of signal priority which may be arranged in a descending order access (sometimes referred to as 'ladder priority'), or an equal access first-come-first-served priority, or any combination of both. The modules available may be categorised into 'priority' and 'passive' modules, and it is the 'priority' modules which generate the ladder sequence. Thus if a **MACRO** amplifier were fitted with say five priority modules, then obviously only a maximum of five levels of priority could be available. However, the amplifier containing the five modules may be set up to exhibit ladder priority, for example, on inputs 1 and 2 whilst inputs 3-4-5 may be given equal access. This set-up could now be referred to as exhibiting just 3 levels of priority.

Equal access is a form of priority whereby the first to access the priority chain locks out one (or more) other inputs for the duration. As supplied from the factory, the amplifier will exhibit a ladder sequence downwards from input No.1 as first priority. Equal access between any modules must be between physically adjacent modules, and is instigated by depressing the small blue PCB switch button which is located between the module input sockets on the main mother PCB. See Fig. 3. Later units utilise a DIL or Molex type switch, which should be set to 'ON'. There are 7 such switches, and any number may be depressed at any time to give the required priority arrangement.

MACRO systems may be designed to include music or other non-priority facilities, and the appropriate modules will have been specified. All such modules are 'passive' modules and as such should occupy module sockets at the lowest end of the priority chain. i.e. towards input No.8. Passive modules will be overridden by any priority modules in the chain, but have no facilities to instigate any priority functions (such as current sinking) of their own.

In all cases, the priority functions of priority modules are triggered by bridging pins 4 and 5 of the DIN channel input socket. The switching current is in the order of 2mA @ 15V. On successful access to the signal priority chain, the module circuitry will perform certain functions:

- a) Modules of equal or lower priority will be inhibited, whether of priority or passive format.
- b) The audio signal path of the accessed module will be enabled
- c) The channel current sink (250mA max) will be enabled
- d) The 'any channel' current sink will be enabled (250mA max)
- e) The modules in immediately higher priority will be inhibited if the equal access PCB switches have been set
- f) The tone sequence of a tone generator module will be started either via the module timer circuit, or momentarily for the duration of the trigger
- g) The chime sequence of a chime-microphone module will be triggered and consequently enable a CDM (chime duration monitor) current sink to be energised (250mA max).

Should a module which is currently in an accessed mode be inhibited by the triggering of a higher priority module, all the above functions (a) to g) where appropriate) will be lost immediately, for the duration. However the timer function will still be operative and may re-enable the original module, if timing permits, when the higher priority is released.

Voice operated modules attempt to gain access by triggering on amplitude peaks and the resulting functions are consistent with a) to e) above.

The audio paths of lower priority passive modules will be inhibited for the duration.

FACILITY	USAGE or FUNCTION
Audio gain	Sets the level of amplification of incoming signal. Influenced by no other adjustment
Chime level	Determines the level of chime tone to be injected. Influenced by no other adjustment
VOX sensitivity	Sets level of audio input at which the VOX circuit is triggered. Influenced by 'Audio gain'. Temporarily set sensitivity to maximum, and set Vox delay to maximum to enable 'Audio level' to be set using typical input signal, then reset 'VOX sensitivity' and then 'VOX delay'.
VOX delay	Determines the time delay between cessation of audio input signal and release of priority and/or muting of channel. Influenced by Audio gain and VOX sensitivity. Adjust those first.
Chime frequency	Sets collective pitch of chime sequence. Tones may not be adjusted individually. Influenced by no other adjustments.
Bass cut link	Cut this link to introduce a sensitivity roll-off at bass frequencies. Particularly effective for paging applications.
Sensitivity link	Cut link to change the scope of Audio gain adjustment to 50mV-2V, from 2V-80V RMS.
Priority/passive jumpers	See relevant information on page 12
Timer duration	Sets period of on-board timer within the range 2-30 seconds, after which the priority is released and tone ceases. Influenced by no other adjustments.
Output level	Sets level of audio tone output from module. Influenced by no other adjustment.
Tone generator frequency	Sets audio pitch of tone generation sequence. Influenced by no other adjustments.
ALC threshold level	See Factory Fitted Options - Automatic level control, on page 21. Influenced by no other adjustment on this module.
ALC sensitivity	See Factory Fitted Options - Automatic level control, on page 21. Influenced by no other adjustment on this module.
Surveillance tone level	See Factory Fitted Options - Line surveillance on page 22. Influenced by no other adjustment on this module.s

Table 2 Module adjustments and settings

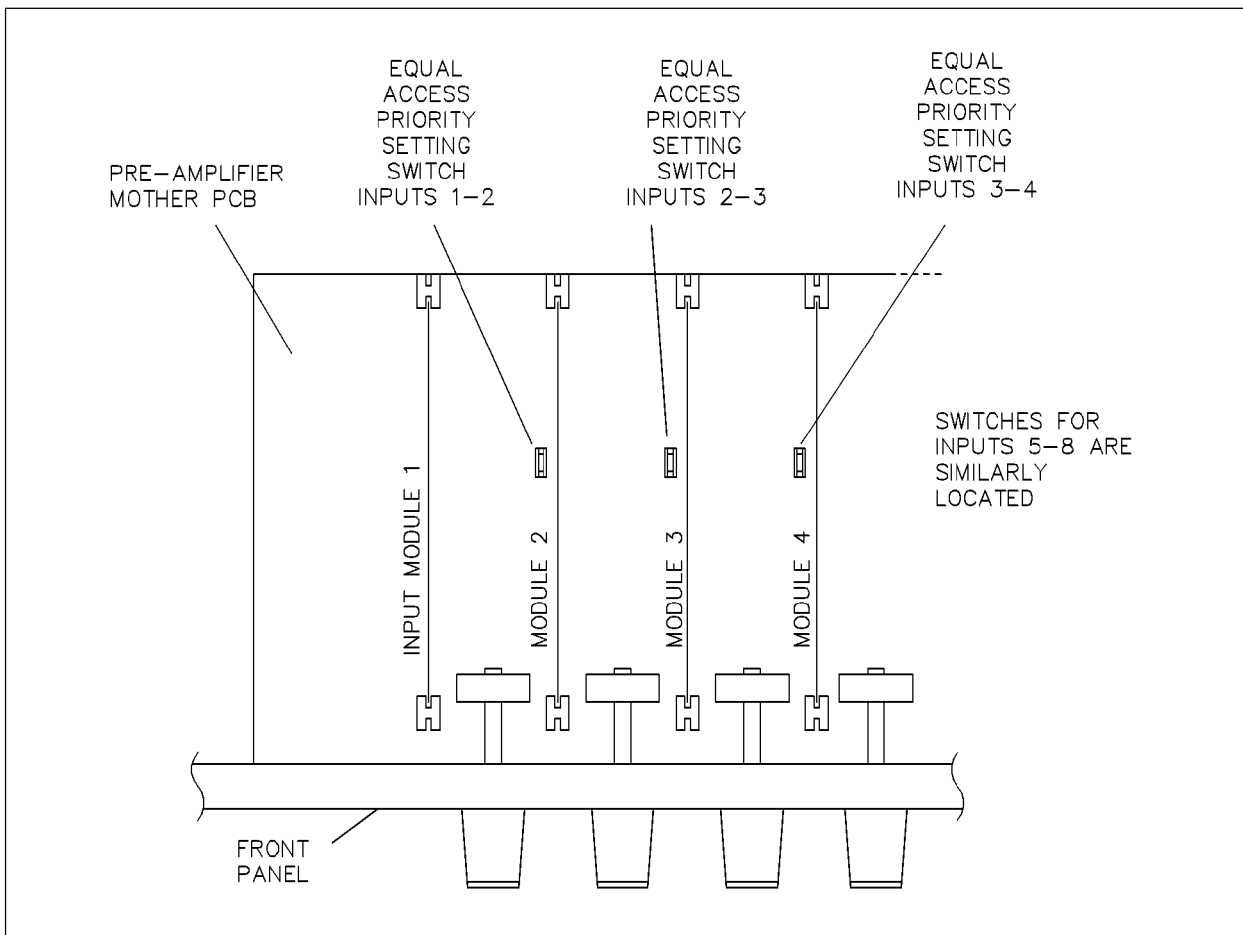

Fig. 3 Location of priority sequence setting switches

Priority/passive setting of modules

Certain modules contain features enabling the commissioning engineer to set them to operate as normal priority modules, or as passive modules. Referring to APPENDIX E, this is accomplished on the M24 microphone input module for example by transposing the position of a jumper link on the module, from lower middle (position B) to lower left (position A) for the change to passive (non-priority) mode. In this mode, the module audio signal path is permanently enabled, though it will be inhibited by access of any higher priority module and is itself rendered unable to inhibit any other module. The jumper link may be changed at any time, and is a simple push fit.

Priority memory

If, whilst a priority module is being accessed, an attempt is made to trigger a tone generator module which is installed in a lower priority level, and which features a priority memory, then no apparent action will result until the higher priority is released, at which time the memory circuit will automatically and immediately trigger the timer circuit of the module, causing it to operate in the normal manner for its pre-set duration.

PRE-ANNOUNCEMENT CHIMES - all units except slave amplifiers

The customary ding-dong chime signals which can often be heard to precede announcements in public buildings, are generated in **MACRO** range equipment by certain standard microphone or line input, and tone generator modules. It is possible therefore to install two or more such modules, and adjust them so as to be readily distinguishable. The chime is triggered only on successful access to the priority chain. See APPENDIX E for location of adjustments.

MIXER FACILITY CONNECTIONS - 0dB SIGNAL ACCESS POINT

This connection may be used to gain access to the output of the pre-amplifier section, or the input of the power amplifier section, at 0dBV level. Standard connection is by Locking 5 pin DIN panel socket with 180 degree pin spacing pattern. Connections are as follows:

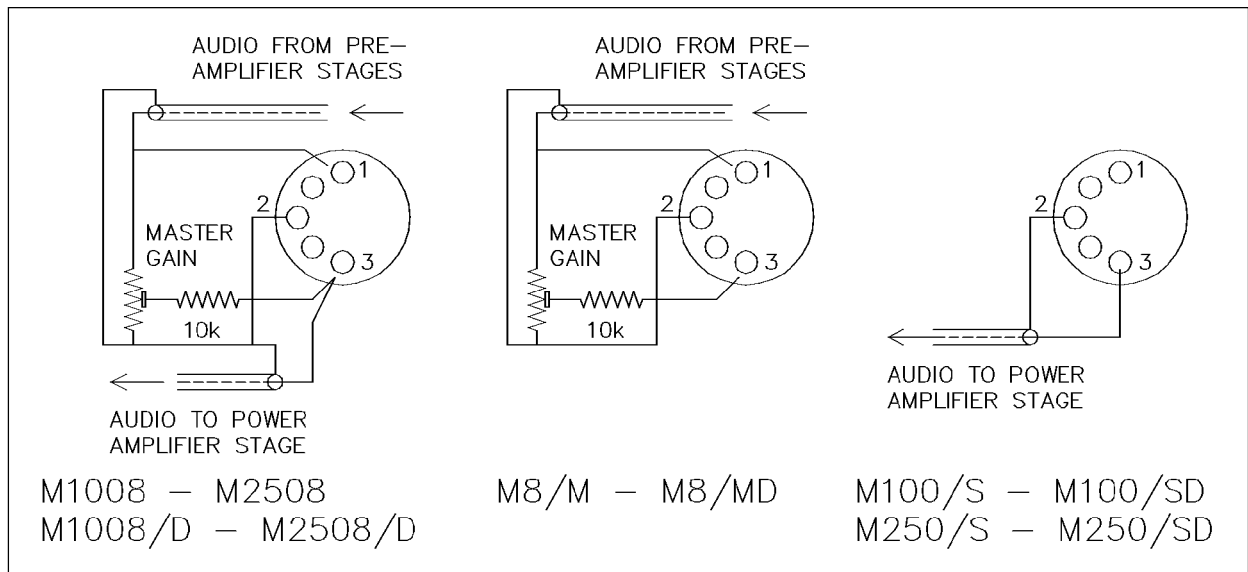

Fig. 4 Mixer facility connections for standard locking DIN connector

0dB signal in/out access for mixers & mixer amplifiers -

The standard Locking DIN pin connections are as follows:-

- Pin 1 Pre master gain control direct from TB.6 module
- Pin 2 Signal earth (cable audio shield)
- Pin 3 Post master gain control (via 10k source)

With the master control at position "0" the loading effect exhibited by pin 3 is approximately 6k8 ohms. For further clarification of this arrangement see the block schematic diagram - APPENDIX A

Input connections for slave amplifier

The standard input circuit is suitable for unbalanced line operation, and the locking DIN signal input connections are:-

- Pin 1 No connection
- Pin 2 signal earth (cable braiding)
- Pin 3 .775v @ 10k ohms power amplifier input

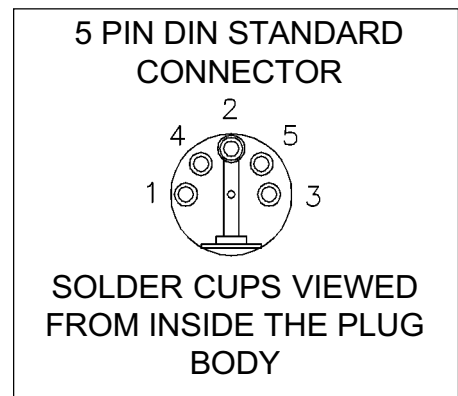

Fig. 5 Mixer facility connector pin identification

Signal arrangements and DIN cable connections are shown in Fig. 4

As a factory fitted option, a line input transformer may be fitted. See page 21 for further details.

Slave amplifiers have a fixed sensitivity and no input control is provided on standard models. The input impedance is approximately 10k ohms. Immediate technical advice for specific problems is available from the Technical Services Department, Mustang Communications Ltd. Please also see the section of this manual which covers earthing and earth/hum loops, on page 20.

Tape recording

The mixer facility socket of mixers and mixer amplifier units will provide suitable signals for tape recording, though it will normally be necessary to make up a suitable recording and/or playback lead.

This socket is associated with the master gain control, so either pin 1 or pin 3 of the standard Locking DIN connector may be taken as the signal connection dependent on whether the recorded signal is to be influenced by it:-

- Pin 1 signal non-dependent on master gain control
- Pin 2 signal earth (cable braiding)
- Pin 3 signal via master control

For recording on a stereo recorder connect both left and right channel signal input connections together to pins 1 or 3 as required.

The manufacturer's handbook should be consulted to ensure that the recorder will accept signal levels of approximately 0.75V without distortion and that the recorder does not short out the signal recording connections when in the playback mode. In either case, insert a resistor of suitably high value in series with the recording lead. An experimental starting value would be 22k ohms. See Fig. 6

Certain tape decks send a signal from the tape playback output during a recording session. If, in this case, the recording and playback leads are connected simultaneously to an input channel of the amplifier, a closed-loop feedback path to the amplifier will result and cause problems unless the loop is broken. This in its simplest form would necessitate disconnecting the tape playback lead whilst recording, or alternatively, reducing to zero the amplifier input gain control associated with playback.

Tape playback

A playback signal would preferably be routed through a standard line input module (L25, L33, L34 etc) which accommodate a wide variety of signal levels. The module may be located in any module position. The L25 for example has a floating input circuit, and

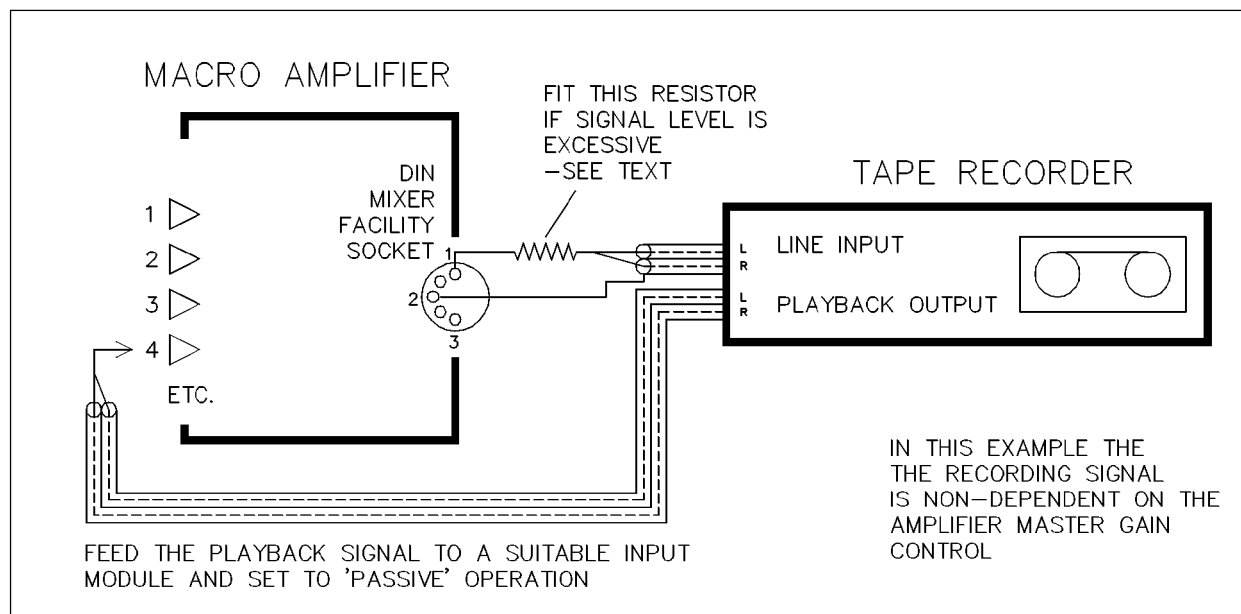

Fig. 6 Tape record and playback connections

would be most useful where hum loops are likely to be a problem - such as in complex sound installations. See the module details for connection data. The module will need to be set to the "passive" mode of operation - see page 12.

Interconnection of several amplifiers

Larger scale amplification systems may necessitate the interconnection of several amplifiers. The most usual situation would be the attachment of extra slave amplifiers to a mixer amplifier in order to increase the available power output whilst delivering the same program. This is made possible by linking the appropriate mixer facility socket pin (pre or post master gain where available) of the mixer amplifier to the input pin of the slave amplifier(s). The cable should be single conductor screened, and the braid/shield connections should also be made between the appropriate pins. See Fig. 7 for clarification.

NOTE: This is the only means of interconnection that is permitted. It is most inadvisable to attempt to combine the loudspeaker outputs of several amplifiers into one loudspeaker feed line. At the very least, severe problems, and most likely serious damage will result.

The loudspeaker system should always be planned such that it is divided up into sections, each of which will be powered by just one amplifier output section.

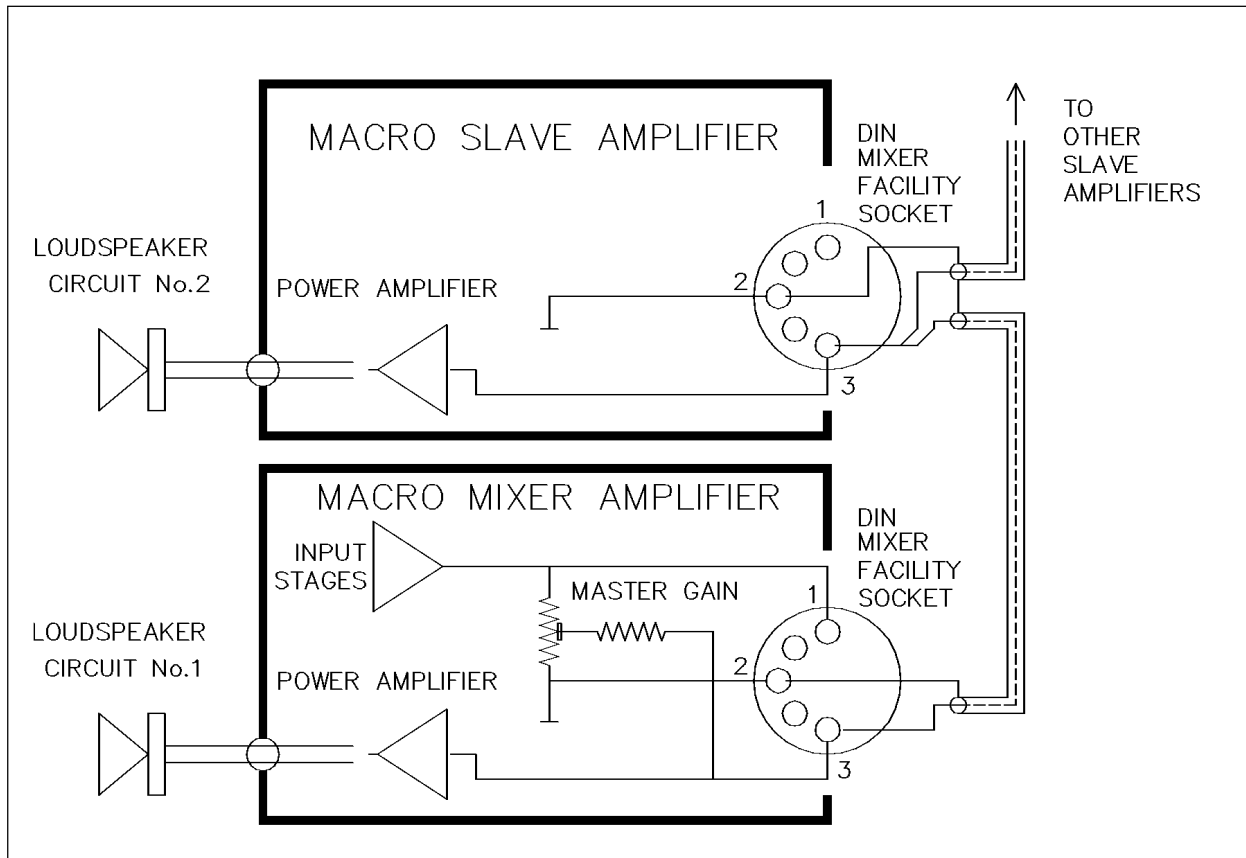

Fig. 7 Interconnection of several amplifiers

POWER AMPLIFIER MODULE

The power output stage of the amplifier including all low level drive circuitry, and output devices are contained in a module which is bolted to the rear panel by four screws. The module is connected into circuit by push-on tab connectors facilitating easy change of a suspect module. The module may be unbolted and swung out to enable circuitry to be worked on with power connected, though as the heatsink is no longer coupled, the module should not be driven into a load for any length of time. Output devices are mounted on sockets so they may be replaced without dismantling the PCB from the heatsink plate. See Fig. 8

Adjustments There are three pre-settable adjustments on the power output module which are accessible from the top of the amplifier. When received from the factory, the amplifier will have been adjusted for correct overload protection, output device biasing, and input sensitivity, and no further adjustment will be necessary. The recommended adjustments are:

OVERLOAD: Top left of module when viewed from front: Set for tripping at full amplitude on a load of 3 x rated output.

OUTPUT DEVICE BIASING: Centre top of module: Set nominally for a total module drain of 200mA, measured via the supply push-on tab.

INPUT SENSITIVITY: Top right of module: Set for 0.775V RMS at 1kHz.

The above adjustments necessitate the use of certain test equipment and facilities, and the precise methods are outside the scope of this manual. The adjustments may be identified by referring to Fig. 8

The front panel 'error' LED is energised for a minimum period of 1.5 sec. when an output overload condition is detected. During this time, the signal drive to the output stage is suppressed.

The detection circuit and LED will remain energised for the entire duration of any such overload, and the amplifier will return to normal operation 1.5 second after removal of the overload. Note therefore that this circuit will not register an overload until a suitable signal is present.

LOUDSPEAKER OUTPUT

The amplifier is designed to work primarily with 100V line loudspeaker systems. Facilities are also provided for 50V line and low impedance loads. IT IS ESSENTIAL to provide the correct loudspeaker load for safe and distortion-free reproduction.

When connecting a **MACRO** mixer amplifier or slave amplifier onto an existing loudspeaker network, the load should be ascertained by measuring the load by a proprietary impedance bridge

The cover provided on the output barrier terminals is a safety cover and should be retained. Access to the terminals is gained by

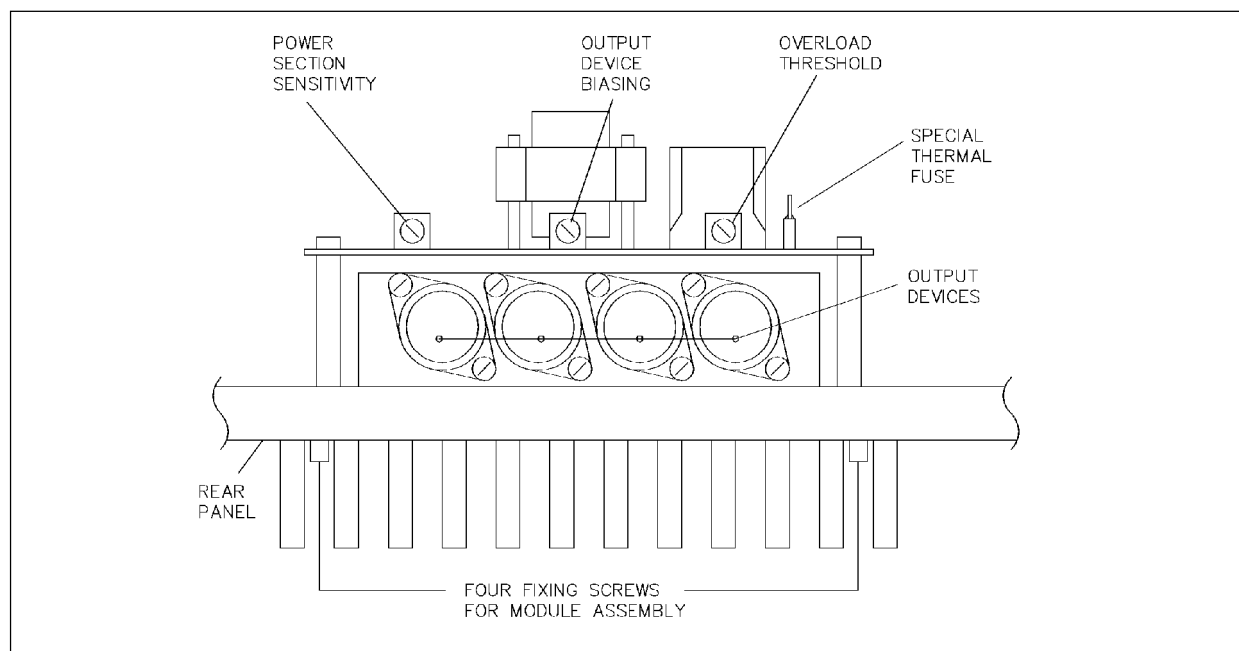

Fig. 8 Power amplifier module fixings and adjustments

removing the 4BA nut on the left and lifting that end clear of the stud. The cover may now be swung round. 100V output

The general concept of a 100V line loudspeaker system is that a quantity of 100V line loudspeakers are connected in parallel across the amplifier output terminals. The loudspeakers may be arranged in any order, any combination and if necessary, using any number of feeds from the amplifier. They may be grouped onto sub-circuits which may then be controlled by switching or group volume controls, etc., as required to suit the operational requirements of the system. Sub circuits may be dedicated to 'Page-only' operation and switched in by means of relays powered by the comprehensive **MACRO** current sinks. See APPENDIX C for typical arrangements.

The 100V line loudspeaker output terminals will deliver conventional full program content, i.e. all music and all paging/priority signals. For 100V line loads connect between the two outer terminals and for 50V line systems connect between the centre and right terminals.

All three 100V line output terminals fully floating, earth-free, and centre-tapped. This latter is useful in certain critical installations where careful balancing of the loudspeaker network may be necessary. The terminal marked 'CT' may be earthed to chassis if required.

Low impedance output

Power output to the loudspeaker load may be taken at low impedance (low Z). The terminals marked A-O-B present a very low impedance output across A-B and which is centre-tapped at O. These terminals are not specifically rated, but as a guide, the output impedance across the A-B terminals is in the order of 2 ohms. The centre-tap is a direct connection to 0V level (chassis, signal earth, and -24V).

Typical loudspeaker load arrangements

The following are acceptable examples of loudspeaker loading arrangements:

- A 400 x 1/2 Watt 100 Volt line speakers = 200 Watts total load to the amplifier. Use a 250 Watt amplifier
- B 200 x 1 Watt 100 Volt line speakers = 200 Watts total load to the amplifier. Use a 250 Watt amplifier
- C 2 x 50 Watt 100 Volt line speakers = 100 Watts total load to the amplifier: Use either a 100 Watt amplifier (or a 250 Watt amplifier to allow for 150 Watts future development).
- D 12x 5 Watt 100 Volt line speakers = 60 Watts total load to the amplifier, and therefore 40 Watts spare capacity for future expansion if using a 100 Watt amplifier
- E 10 x 5 Watt, and 6 x 2 Watt 100 Volt line speakers = 50 + 12 Watts = 62 Watts total load to the amplifier. Use a 100 Watt amplifier.
- F 4 x 60 Watt units each tapped at 30 Watts, and 20 x 4 Watt units tapped as follows: 5 @ 4 Watt, 5 @ 2 Watt and 20 @ 0.5 Watt 100 Volt line speakers = 160 Watts total load and therefore 90 Watts spare capacity for future expansion or for final adjustments. Use a 250 Watt amplifier

See APPENDIX C for typical loudspeaker arrangements.

AUXILIARY OUTPUT CONNECTION

A standard 25 way 'D' connector on the amplifier rear provides all the auxiliary connections associated with current sinking, alarms, auxiliary DC and signal outputs, etc., where applicable. The standard connections are as follows:

1	250mA current sink activated by input module No.1 during priority access	
2	250mA current sink activated by input module No.2 during priority access	
3	250mA current sink activated by input module No.3 during priority access	
4	250mA current sink activated by input module No.4 during priority access	
5	250mA current sink activated by input module No.5 during priority access	
6	250mA current sink activated by input module No.6 during priority access	
7	250mA current sink activated by input module No.7 during priority access	
8	250mA current sink activated by input module No.8 during priority access	
9	250mA current sink bus activated by any module gaining priority access	
10	250 mA CDM current sink bus activated by any module with this feature	
11	0V for general purpose	
12	Nominal 24V+ DC unregulated output, for use with current sinks	
13	} Mains power input failure alarm contacts - normally open	
14		
15	} DC power input failure alarm contacts - normally open	
16		
17	} process/equaliser control for future use.	
18		
19		
20	nc	
21	nc	
22	nc	
23	50V	} duplication of 100V loudspeaker output terminals
24	0	
25	50V	

Notes:

a) The current sink connections originate on individual modules. These current sinks are unfused and can carry a maximum of 250mA from a positive (+ve) source.

b) The pin 12 connection originates from the pre-amplifier stabiliser module (PS.9 etc.) where a F1A fuse is located - see APPENDIX E

c) The 'fail' alarm connections are 'open' when the unit is de-energised, and closed during normal powered operation.

Priority controlled DC current sinks

This unusually comprehensive feature is rarely found on general purpose amplifiers but is useful in microphone paging or alarm systems where a number of operations may be required co-incident with the use of the priority facilities, e.g.

- a) The introduction of 'page only' 100 Volt loudspeaker circuits by using relays to switch them on only during paging.
- b) The restoration to full volume of a remote 100 Volt loudspeaker group volume control, such as the Mustang MVC series.
- c) The powering of lamps at a microphone position, to indicate that the amplifier priority system is already in use (by an alarm tone generator for example)
- d) The interruption by means of a relay of the sound output of another amplification system.
- e) The sending of a low-level paging signal by means of a relay, to another remote amplification system
- f) Control of a designated loudspeaker zone control unit from the Mustang ZC or MC ranges.

The principle of operation is that when the signal priority circuit of any of the input modules is activated, the associated DC current sink is operated and the associated terminal of the Auxiliary output connector - becomes a 0 Volt point. This is used to complete a simple external circuit comprising relays or lamps etc., connected to the +24V DC terminal.

Terminals 1-8 are individual sinks controlled individually, whilst terminal 9 is activated whenever ANY of the individual sinks is operated.

The current sinks are polarity protected for use in positive (+ve) applications up to 40V. DO NOT ATTEMPT to pass more than 250mA.

NEVER connect the +24V and current sink connections directly together - serious damage to the module will result. In the off state there is effectively no connection.

See APPENDIX B for typical applications of the Auxiliary Output connections.

Chime duration monitor sinks - (CDM)

This facility is provided on those modules which feature a chime generator. The sink output lasts for the duration of the chime tones (which are triggered on priority access) and the individual sinks are connected to a sink 'bus' so that a lamp may be energised on a paging microphone to indicate at which point to commence speaking. This connection is unfused, and is limited to 250mA from a positive (+ve) source. See APPENDIX B for typical application.

100V line output

This is an extension of the rear 100V loudspeaker output barrier terminals to facilitate all connections to be 'pluggable' if required.

24V DC supply

The 24V+ terminal of the Auxiliary output connector provides an unstabilised DC supply, which is limited to 1 amp by an internal fuse on the pre-amplifier stabiliser module (see APPENDIX E) and the return is via the 0V terminal. This feature would normally be used with the DC current sink.

COMBINING THE INPUT/OUTPUT FACILITIES OF TWO OR MORE UNITS

This may be considered where one single amplifier cannot provide enough input facilities or output power for a particular application. Mixers may be combined with mixer amplifiers, and with slave amplifiers in any combination via their respective mixer facility sockets.

Example M2508 and M250 to provide 8 inputs and 500 Watt output to two loudspeaker zones. Interconnect using pins 3 of each mixer facility socket.

Example M2508 and two M100 to provide 8 inputs and 450 Watt output. Interconnect using pins 3 of each mixer facility socket.

Example M8/M and M1008 to provide 15 priority inputs and 100 Watts output capability. Fit an L.25 module in input 1 of the M1008 and drive it from the mixer facility output of the M8/M. Connect the 'ANY' sink of the M8/M to pin 5 of the input No.1 M1008 such that any priority operation of the M8/M seeks access to input No.1 M1008 as though a normal input. All individual sinks on either unit will still be relevant. The mixer facility of M1008 may be used to drive slave amplifiers in the same system if required. See Fig. 9 for clarification.

NOTE

The loudspeaker system should always be planned such that it is divided up into sections, each of which will be powered by just one amplifier output section.

It is most inadvisable to attempt to combine the loudspeaker outputs of several amplifiers into one loudspeaker feed line. At the very least, severe problems, and most likely serious damage will result. Whilst it is technically feasible, the risks faced will render it an impractical option. For clarification, consult the System design department of Mustang Communications Ltd.

POWER SUPPLY

AC Mains power input

A standard IEC 3 pin mains connector is supplied with each **MACRO** amplifier. It is essential that the Earth connection is made properly, as the chassis of the amplifier is earthed via this facility. The mains power required is 230V to 240V AC at 50-60Hz. If a slightly lower voltage is used, then the battery charging facility (if fitted) may be impaired.

The power requirement for the amplifier, even when used at full power, is minimal and should be taken from the AC mains supply via a 3 core flexible cable. It is vital that the connections to the mains input line socket are made to the correct terminals. The connections are:-

L	Live
N	Neutral
E	Earth

DO NOT operate the amplifier under any circumstances without an electrical earth connected. This is a permanent safety earth.

DC power input (if applicable)

Certain models in the **MACRO** range are designed to operate from 24V DC during periods of mains supply failure. It is permissible for this voltage to vary between 20V and 28V without undue problem, though the battery charging capability will vary accordingly. A style MS.62 military style connector is supplied with each amplifier, and the corresponding connections are printed alongside the panel connector, as follows;

Pin A	+24V
Pin B	Chassis
Pin C	-(0V)

Important: If either positive or negative terminals must unavoidably be earthed, it is preferable that it be **NEGATIVE**. Note that the DC connections are not totally free of earth, as the signal earth and DC (-) of the amplification are connected to chassis by a 220 ohm resistor.

Any conflict of DC earthing is likely to result in severe damage to the module printed circuit tracks should incoming circuitry be earthed too.

Systems powered by both AC and DC supplies

Systems utilising several **MACRO** amplifiers to be powered from both AC and emergency DC supplies should be connected such that the AC is supplied by the routine mains supply - for normal operation, and upon failure of this, the DC is supplied from an emergency DC battery system with integral charging circuitry. The internal **MACRO** battery charger circuit should be disabled (see below).

For clarification see Fig. 10

Main ON-OFF front panel switch

For mains powered **MACRO** equipment (or non standard DC only units) a two pole switch is used. Mains powered units are switched in the Neutral and Live connections. DC units are switched in the +ve DC input connection only.

AC Mains/DC equipment utilises a three pole switch which combines both the above functions.

Due to the very high inrush current of an AC mains/DC powered **MACRO** amplifier, a time lapse circuit and holding solenoid are employed. The DC section of the power switch therefore carries minimal current. This is not a feature of mixer units.

If a loaded slave amplifier is subject to an input signal during the switch-on sequence using only the DC input, the resulting drain on the time lapse circuit may prevent the holding solenoid from operating properly.

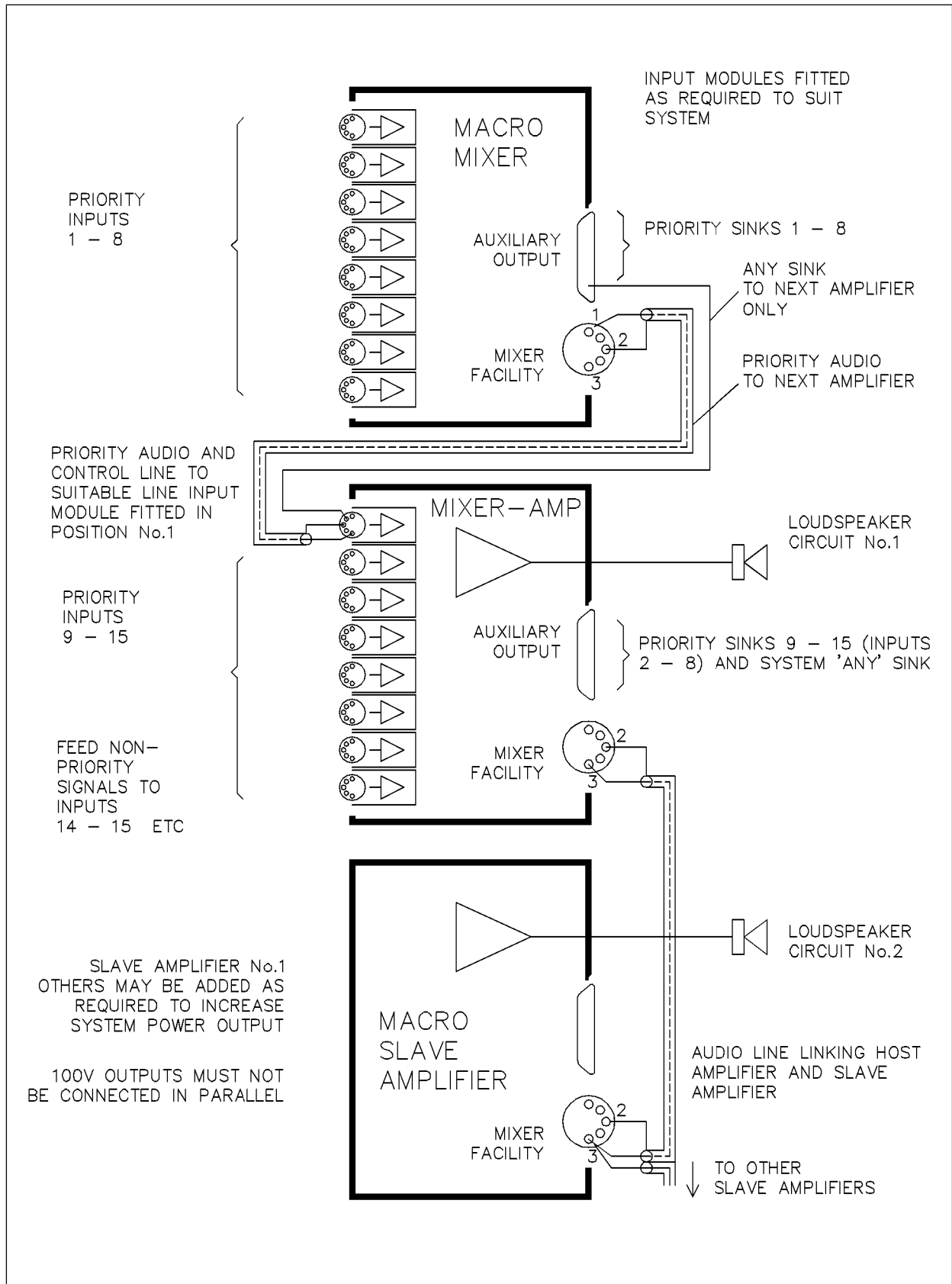

Fig. 9 Priority connections for multiple amplifier systems

The front panel of the power switch may be removed by light leverage to enable lamp replacement. Power for the lamp is derived from a small 18V stabiliser on the Power Management Board.
Failure to illuminate will indicate one of the following:-

- a) Lamp failure
- b) Neither AC nor DC power to the amplifier
- c) Both AC mains and DC fuses on the rear panel have failed
- d) Stabiliser circuit has failed

'ERROR' status indicator LED

Illumination of this LED is as a consequence of the overload protection circuit in the power output module being triggered. This could be as a result of the following:

- a) A severe overload on the loudspeaker line
- b) Transitory saturation of 100V line loudspeaker transformers connected to the 100V line terminals.
- c) An electronic fault in the power output module drive circuit.

Illumination resulting from a) or b) will occur only whilst an audio drive signal is present. During periods of illumination the amplifier output will be muted and minimal current will be drawn from the power supply. This condition can be maintained indefinitely without further risk to the amplifier.

'POWER' status indicator LED

A three colour LED is used to indicate the integrity of AC and DC power supplies:

- Green AC supply connected
- Red DC supply connected
- Orange AC an DC supplies connected

Power supply failure monitoring

The 'Auxiliary' output D connector provides the facility to monitor the integrity of both the AC mains and DC standby supplies. Each supply energises a relay with light duty normally open contacts which are taken to pins 13/14 and 15/16. The relays are located

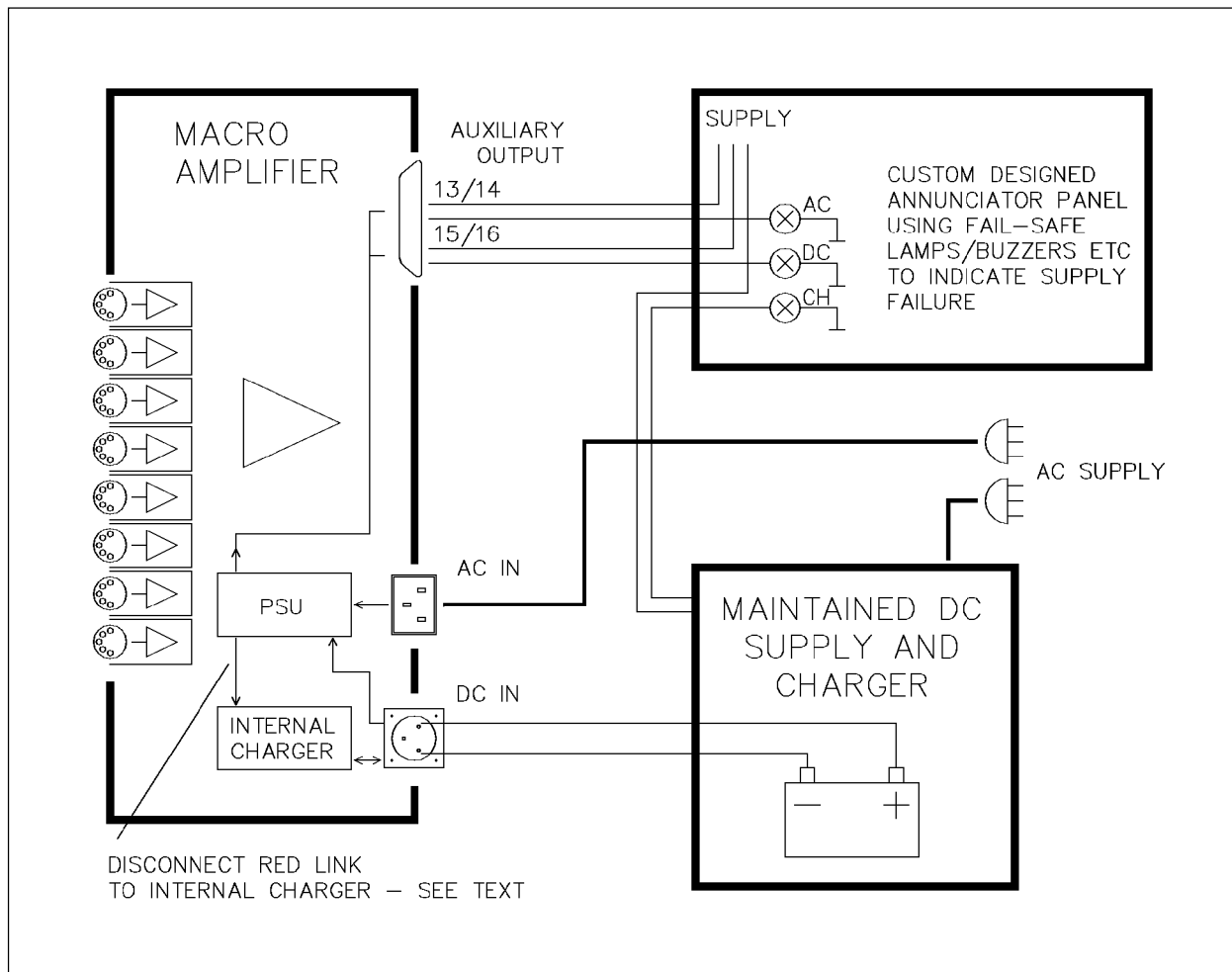

Fig. 10 AC & DC supply connections and monitoring

on the Power Management Board and will drop out as a result of :-

- AC: AC supply failure
AC fuse failure
AC supply disconnection
Amplifier switched off
Rectifier circuit failure
- DC: DC supply fuse failure
DC supply disconnection (even with charger operational)
DC standby supply failure
Amplifier switched off

These relay contacts may be used to trigger remote audible or visual alarms within the system to draw attention to a possible problem.

Power supply change-over

This function is carried out automatically and instantaneously upon failure of the regular AC mains supply. There is no break in service and all facilities are retained (except battery charging), for the duration of the condition. Upon reinstatement of the AC supply, the amplifier automatically reverts to AC operation and battery charging re-commences.

The change-over process may be monitored by making use of the power supply failure monitoring relay contact mentioned above. See Fig. 10 above, for clarification.

Battery charger circuit

Units except mixers provide trickle charge facilities for use with standby batteries connected to an AC mains/DC amplifier. Output is in the form of a 0.5 second pulse at 1 second intervals and is controlled from the Power Management Board, (PMB.1, etc.). Low AC mains input supplies will adversely effect the charge rate.

If, however, the charging facility is not required - perhaps because the battery system provides its own dedicated charger - then it is preferable to disable the amplifier charger by cutting the red wire link at the end of the heat-sink type power resistor attached to the Power Management Board heatsink plate. See APPENDIX D for identification of this link.

EARTHING AND HUM LOOPS

In all systems it is possible to inadvertently set up a hum loop. Each manufacturer has different methods of earthing his equipment and so lack of familiarity with them may result in problems. A loop will manifest itself as a low level soft hum at either 100Hz or 50Hz which is not generally effected in tonal or amplitude content by any user or adjustment controls. There are many potential earth loop paths in any system, but the larger the system, the more they are compounded, and resolving the problem can be extremely exasperating unless a disciplined and logical approach is used.

Each system must be considered separately although rules of thumb do apply. Generally an audio loop will be set up wherever two points in an audio system are interconnected by two earth paths. The resulting circuit will act as a 'turn' in a transformer, with any stray magnetic fields setting up resultant electrical currents in it. These currents are superimposed on whatever currents are intentionally there, and these may be very low level audio signal currents.

However, the electronic circuitry within the chassis is earthed to chassis independently of the electrical safety earth by means of a wire link or a 220 ohm resistor - dependent upon the unit - adjacent to the mixer facility socket. This provides earthing to prevent self-oscillation whilst avoiding any tendency to cause earth loop problems. (See also the preceding sections covering the 'Mains power input' and 'DC power input' requirements).

In designing the **MACRO** system, we have borne in mind that the applications for the equipment will generally be in large scale installations where there may be many conflicting requirements. Therefore **MACRO** amplifier chassis are always earthed via the power input connections.

***** THIS IS A SAFETY EARTH AND MUST NEVER BE DISREGARDED. *****

Particular care should be taken when terminating the Locking DIN input plugs, as the cable clamp will connect with the plug body on assembly and thence with the amplifier rear panel on insertion. Thus, if the signal cables' audio screen is connected both to the clamp and to pin 2, a loop will result. Similarly with the mixer facility connector. Aim to earth each amplifier fully in one place only, with interconnection of amplifiers or ancillary equipment via input modules featuring transformer input circuitry, - for example L.24 to L.32. These may be wired in a fully floating mode thus providing full isolation. Connect the audio screen of a signal cable to a signal earth at one end only.

Bear in mind, also that with DC powered systems, the signal earth of each amplifier will be connected to the -ve terminal of the DC supply. If that is already unavoidably earthed, it dictates that it must be the central earthing point of the system.

FACTORY FITTED OPTIONS

- TB/ALC Automatic audio level control (ALC)
- TB/S Loudspeaker line surveillance facility
- MAC/LT Balanced line input for slave amplifiers

Free-standing cased units - specified only for earlier models. Originally Mustang product code FS.3U
Current amplifiers specified as rack mounting or free-standing.

A wrap-round sleeve case can only be factory fitted to a **MACRO** unit. A rack mounting unit, once shipped, cannot be fitted with such a case due to the design of front panel being different for rack and free-standing versions.

Automatic level control - all units except slave amplifiers. Mustang product code TB/ALC

The standard module fitted to a mixer or mixer-amplifier to provide line driver facilities is a TB.6 and is located second from the right when viewed from the front. This is replaced with a TB.6A to provide the Automatic level control facility (ALC) and it will enable the system to be set up such that a pre-settable amplitude cannot be exceeded. All signals that would normally pass through the amplifier circuitry are subject to automatic level control operation.

The module operates to produce a fast "attack" so that limiting to a pre-determined level takes place almost instantly, and a slow "decay" whereby the sensitivity - or gain - is allowed to increase progressively over several seconds or until another limit is triggered.

To set the module to give the required performance: Firstly, referring to APPENDIX E, identify the 'GAIN' pre-set control which is adjacent to the integrated circuit at the left of the board approximately half way up. Then identify the 'THRESHOLD' pre-set control which is a little below it. Set the Master Level control on the mother PCB to maximum (see Fig.1 on page 7). Set the GAIN pre-set fully anti-clockwise to give approximately unity gain. Now, whilst running the amplifier at full volume using a test signal, adjust the THRESHOLD to the desired maximum output level indicated by the output meter. Clockwise adjustment increases the threshold level. The threshold is adjustable from -24 dBm to +8dBm.

The module will now be operating as a limiter. To enable the Automatic Level Control aspect, the GAIN control should now be adjusted clockwise until sufficient gain is available to enable the lowest level input signal to attain the THRESHOLD.

The ALC facility will have been specified where -

- a) The amplifier output is required to be limited to prevent clipping distortion;
- b) The average sound level is to be limited to a specific audible level;
- c) Inductive loop systems which may be unattended though still need to operate to the requirements of the current legislation.

As supplied by the factory, GAIN is set to 0dB (unity) and the THRESHOLD control is set to maximum, and therefore no effect will initially be apparent. See APPENDIX D to locate the module, and APPENDIX E for identification of the adjustments.

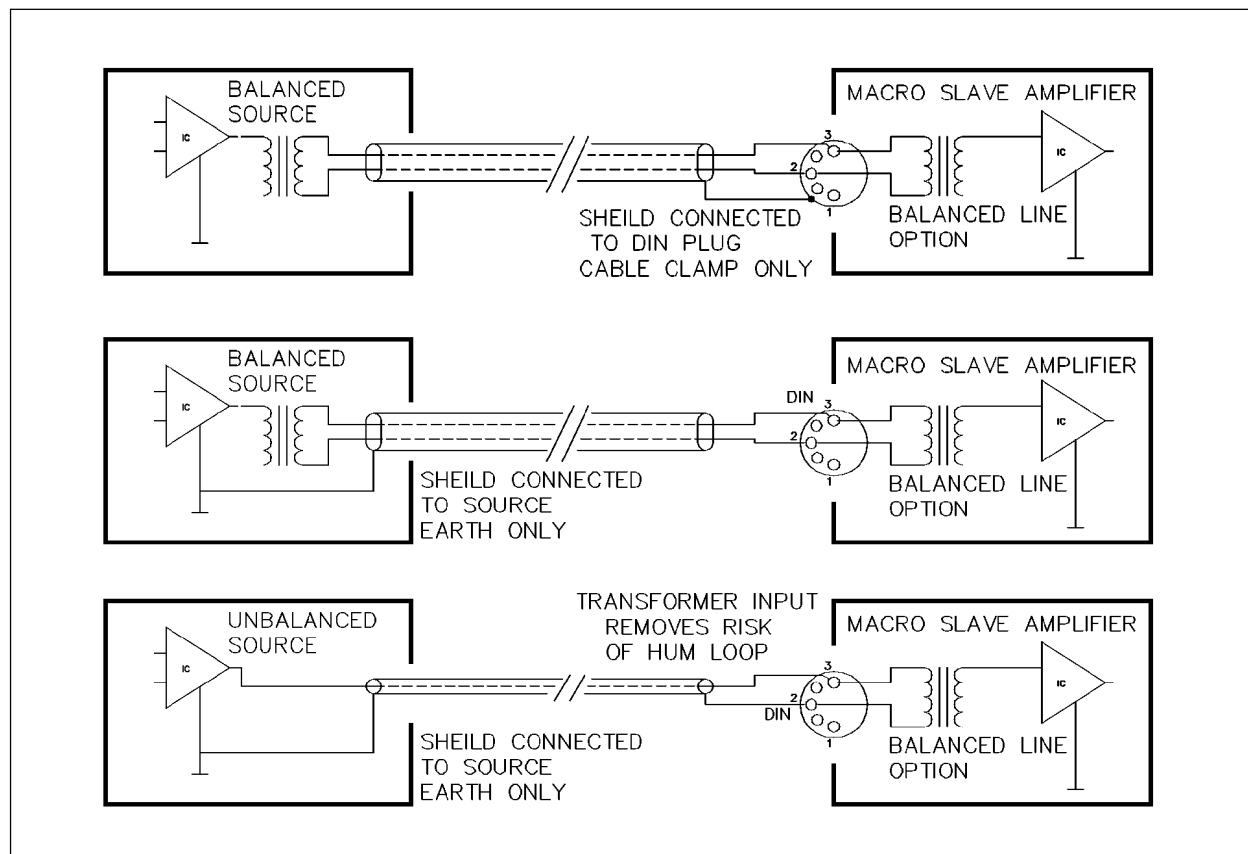

Fig. 11 Balanced line input connections

Balanced line input for M/100 and M/250 slave amplifiers. Mustang product code MAC/LT

This option would normally be fitted where difficulty may otherwise be experienced with hum/earth loops. The input signal circuit has no earth connection, and is referred to as being "fully floating".

The Locking DIN pin connections are:-

Pin 1	No connection	}	.775V RMS @ 10k ohms balanced (floating)
Pin 2	out of phase audio		
Pin 3	in phase audio		

It would normally be appropriate to interconnect two pieces of equipment using twin-screened cable. The braiding should be earthed to one unit only. If the decision is made to use the Mustang power amplifier for earthing, then the cable clamp of the DIN plug may be used for the purpose, without the likelihood of a hum loop.

As this is a fully floating input facility, either single or twin core screened cable may be used. This will depend upon the specification of the equipment supplying the input signal.

The input impedance of balanced input slave amplifiers is 10k ohms.

See Fig. 11 for further clarification.

Line surveillance. Mustang product code - TB/S

The standard module fitted to a mixer or mixer-amplifier to provide line driver facilities is a TB.6 and is located second from the right when viewed from the front. This is replaced with a TB.6S to provide the Line surveillance facility, which, in the **MACRO** system is carried out by injection of an encoded supersonic tone into the audio signal path at the line driver stage. The presence of the current which this signal induces into the loudspeaker line is subsequently monitored externally for deviation from a pre-set level.

The amplitude of the injected signal is adjusted using the pre-set potentiometer at the top right hand corner of the TB.6S (viewed from component side - see APPENDIX E). Turning the control clockwise will increase the level of injection. The correct factory setting is such that 2V is the amplitude of the signal appearing across the fully loaded loudspeaker output terminals at the amplifier rear. Useful re-adjustment of this control can be accomplished only with the aid of an oscilloscope of suitable bandwidth. The same level applies in the case of **MACRO** systems incorporating mixers and slave amplification. See APPENDIX D to locate the module, and APPENDIX E for identification of the adjustments. Adjustment of the modules treble or bass controls will not effect the surveillance injection. Do not attempt to alter the ferrite cored inductor of the injection circuit.

The loudspeaker current monitoring function as mentioned above would be facilitated by using a **MACRO** SL/10 unit.

INSTALLATION

Selection of signal input cables

It is essential that input connections are made carefully, using appropriate screened cable, soldered to DIN connector plugs, and using the appropriate terminal numbers indicated in the section describing the input modules in this manual. Unscreened "telephone" type cables are NOT suitable. Either twin conductor, or single conductor types may be used depending upon the application. For long fixed cable runs, a cable with a conventionally braided outer shield is preferable to a lap-screened type. A conductive plastic shield type is ideal for cables which will be subject to constant flexing such as those connected directly to microphones. Failure to meet these requirements will result in inferior performance, and at worst, damage to the amplifier.

It is not possible in this manual to be specific about the exact types of input cable for use in any particular amplification system, as many practical factors will need to be taken into account. However, as a guide, we would recommend the following:

Balanced lines should be wired in twin, twisted core, screened cable with a conductor size of at least 0.22sq.mm., and preferably 0.5sq.mm. This is equally valid for dynamic or phantom-powered microphones, and line inputs.

Paging microphone lines will need an extra two conductors to operate the priority circuit of the amplifier. These need not be screened. For short runs, (up to 2 Metres), paging microphones may be connected using 4-core overall screened cable, and for longer runs, (up to 10 Mtrs), 4-core individually screened cable. If it is necessary to run a cable over say 10 Mtrs, then there may be some performance advantage in using a separate twin-twisted screened cable for the audio, and a separate twin unscreened cable for the priority operate cores.

Line level cables, such as those between a tape recorder and the amplifier, which may be up to a few metres in length are less critical and may be run using lap-screened, single or twin cable with conductors of 7/0.1mm or 7./0.2mm.

Selection of loudspeaker cables

Use of an appropriate cable for the connection of loudspeakers to the amplifier will ensure that a minimum amount of audio power is lost during transmission to the loudspeaker network. The loss will depend upon several factors - loudspeaker loadings, size of cable conductor, length of cable, etc.

As a general rule, for any particular loudspeaker system, the longer and the thinner the cable, the greater will be the loss. We therefore recommend, that the system is planned such that the amplifier is as near as possible to the loudspeakers, and that the cable used is as large as practicable.

Mineral insulated cables may be used without problem.

Either solid or flexible conductor cables may be used, or a combination of both. It would be appropriate for a heavy duty cable to be used between the amplifier location and the general loudspeaker location - carrying the full load, and for the subsequent loudspeakers of the network to be interconnected with thinner cable.

Fitting Locking DIN connectors

Signal input connections are made via a locking DIN 5-pin plug (Mustang Code 5-180). To insert:- rotate the plug until the pins line up with the corresponding socket contacts, and push fully in. Rotate the locking ring clockwise to secure. Similar plugs used for domestic Hi-Fi systems may be used though they are generally of inferior quality, and have a weaker cable clamp with no locking facility.

When connecting the input cables to the locking DIN plugs, it is most important to observe the following:-

- A. DO NOT allow the cable braiding/shield to contact the cable clamp, plug body or fixing screw. An earth/hum loop will result. This topic is fully covered on page 20.
- B. Application of silicon grease to the cable outer sleeve will facilitate easy insertion into the grommet.
- C. Be careful when soldering. Avoid bridging adjacent pins of the locking DIN connectors with solder. If pins 4 and 5 are not to be used, break them off to provide extra space for soldering.

Siting

The position chosen for installation of the amplifier will depend upon many individual factors outside the scope of this manual. However, the amplifier should be positioned as close as possible to the loudspeaker network, to minimise losses. Ideally, loudspeaker cables should be routed separately from sensitive microphone cables to avoid the possibility of spurious coupling and resultant oscillation. Please also refer to the following paragraph on ventilation. Choose a position where there is little likelihood of any liquid being spilled on the amplifier.

Ventilation

Individual mixers and amplifiers in the **MACRO** range develop very little heat when switched on and not in use. M8/M and M8/MD units develop virtually no heat in use and need minimal ventilation. Mixer amplifiers and slave amplifiers develop moderate amounts of heat dependent upon the amount of sound power delivered to the loudspeaker loads. The design of these amplifiers is such that heat is conducted from the rear panel across the whole of the chassis which is in effect a very large heatsink and designed to dissipate the heat by convection. However, in order to do this the amplifiers needs ventilation space at least at the rear and sides. Rack mounting amplifiers in irregular or spasmodic use may be stacked as required provided that there is sufficient free flowing air at the rear.

If several 250 Watt amplifiers, are mounted in a rack, and used in a demanding application e.g. alarm tone generation, continuous full power music, etc., then it is likely that the heatsink temperature will exceed 100 degrees centigrade at which temperature certain components will start to be thermally stressed. This can be inconvenient (or dangerous in an alarm generation system) and consideration should be given to spacing the amplifiers. A 1U space should be provided between every second amplifier, and for systems over 400 Watts, forced ventilation should be considered. Mustang FP.2S or FP.2B fan panels and corresponding ventilation panels may be specified. The amplifiers' naturally long operational life may be realised by a cool operating environment.

To summarise, if **MACRO** amplifiers are to be used at high power levels DO NOT:-

- A) install in small enclosed spaces
- B) stack in rack cabinets without adequate cooling, spacing, or ventilation
- C) install above radiators or near heaters
- D) block-in side and/or bottom surfaces

Interference

Steps have been taken in the designs of the range to minimise interference from external sources. The main possibilities would be -

- a) faulty or insufficiently suppressed lighting dimmer
- b) incorrectly shielded or earthed lighting dimmer
- c) lighting dimmer lines close to signal input lines
- d) strong radio/TV transmission immediately adjacent
- e) faulty fluorescent tubes or tube fittings
- f) unsuppressed heavy electrical contacts
- g) stray magnetic fields from other mains equipment adjacent
- h) computer, calculator, or related equipment adjacent

The source of interference should be established by elimination and logic, and equipment repaired or modified accordingly, rather than attempting modifications to the amplification equipment.

Removal of control knobs

Mixer and mixer-amplifier units are fitted with removable control knobs to deter tampering. Remove simply by pulling firmly away from the front panel. The knobs are of the collet type, and will disconnect the splined spindle from the potentiometer inside the chassis. The panel holes may be plugged using the blanking plugs supplied. They are a push-clip fit and cannot be removed from outside the amplifier. The knobs and spindles may be replaced at any time.

Checklist

During the commissioning of the amplifiers in the **MACRO** range, various options are available to the engineer to enable him to meet various technical requirements and the operating requirements of the user:

- Use of priority or passive operation for input channels
- Priority control out to remote relays, lamps, etc.
- Individual input module sensitivity adjustment
- Bass cut on microphone input module
- Timer setting of tone generator modules
- Pre-announcement chime level
- Optional auto level control adjustment (ALC)
- Control knobs to be removed

FUSES

Fuses for the protection of both the AC and DC supplies are located on the rear panel.

Certain fuses are contained within the chassis of **MACRO** equipment rather than on accessible front/rear panels:

- (A) F1A pre-amplifier DC fuse on the pre-amplifier stabiliser module
- (B) F1A auxiliary DC fuse on the pre-amplifier stabiliser module
- (C) Special fusible link on the power output module

See APPENDIX D and APPENDIX E for identification.

Failure of the top fuse (a) could indicate a problem in the stabiliser module or within the subsequent mixer circuitry. The lower fuse (b) protects the Auxiliary +24V DC output (pin 12 of the 'D' connector). It is rated at 1 Amp and if this supply is used to source current for the priority current sinks transistors, then these may have been damaged by the overload. These sinks are located on each priority module.

The failure of fuse (c) would indicate that the power output module has been seriously damaged. Output transistors and associated driver transistors may have failed, so simple fuse replacement is therefore inadvisable.

If a fuse blows repeatedly, a fault is indicated. Do not attempt to force the amplifier by fitting larger fuses. All standard fuses should be replaced as a matter of routine every year if in regular use.

When replacing fuses, disconnect the mains supply and allow a few minutes for capacitors to discharge.

REPAIRS AND MAINTENANCE

Should components be required for replacement purposes, these may be obtained without delay from the address on the cover of this manual. It would be preferable to use original specification components rather than improvise or modify the amplifier.

The **MACRO** range of amplification has been planned so that servicing and maintenance is extremely uncomplicated. All main potential sources of failure are either pluggable or accessible from the top of the main circuit board. It is unlikely that the main board will ever need to be removed except for the removal of spilled liquid, or broken mechanical parts. The following information is a procedural guide for the most likely problems.

Free standing case removal

Free standing cased amplifiers are dispatched with the case fitted and to make any internal adjustments or module changes it will be necessary to remove it. Turn the amplifier upside-down on a clean soft surface to avoid scratching and remove the four outer cross-point headed screws. Revert the amplifier and using strong finger pressure, push out the bottom flanges at both sides of the case, and slide it upwards over the chassis. Replacement is a reversal of this process. Line up the holes in case and chassis before attempting to re-fit the screws. Use the correct size of screwdriver.

The case is manufactured from PVC clad aluminium and therefore, whilst being washable it will not withstand any direct heat, i.e. cigarettes, soldering irons etc.

Removal of main pre-amplification circuit board

Remove the gain control knobs and associated spindles by pulling firmly. Remove all the modules. Spring in the 8 plastic support pillars, spaced along the board. By lifting the rear edge of the board it will now be possible to push to board backwards and upwards giving access to the bottom of this board. De-solder the signal cableform if complete access is required.

WARRANTY

This amplifier should operate successfully for many years if installed correctly. However, should any fault occur within 24 months of installation, irrespective of usage or application, the manufacturer undertakes to replace parts, or the whole unit, at their discretion, free of all labour or parts charges. However, should investigation of such a fault indicate operation of the unit outside its specification, then the manufacturer reserves the right to levy an appropriate repair charge.

Should a fault be suspected, your dealer should be notified in the first instance. All returns should be made via your dealer, forward carriage paid, and be accompanied by details of:

- a the reported symptoms
- b brief details of the installation.
- c details of the circumstances of failure

Following the routine warranty period, Mustang amplifiers may be returned via your dealer, to the manufacturer for any necessary repairs or refurbishing. Details of the work required/reported fault must accompany the unit, and nominal charges will be levied.

FAULTS - SYMPTOMS AND CHECKLIST

The following list of fault symptoms and check points cannot be considered as comprehensive, but as a guide to the most likely faults and causes. We assume that the input sources and loudspeakers are properly connected and in good working order. Be sure to check these carefully first before investigating the amplifier.

	FAULT SYMPTOM	CHECKLIST
1	Sound off, main power switch lamp off	AC mains fuse, mains lead, mains power, mains switch. DC supply, fuse, or leads.
2	Sound off, main power switch lamp on	Internal AC/DC power fuses, output transistors, input connections, module edge connectots, output transformer continuity, pre-amplifier stabiliser module, line driver module, priority channel not being triggered, input module not being set by dedicated jumper pins, input module being muted by operation of higher priority.
3	Sound faint	Module sensitivity adjustment, incorrect output connections, overload on mixer facility socket, incorrect input pin selection, incorrect choice of input module.
4	Sound loud but distorted	Incorrect choice of input module, incorrect module sensitivity setting or pin selection, incorrect loudspeaker load, volume control too far advanced, system requires amplifier of greater power or more efficient loudspeakers, master control set too low.
5	Sound distorted on bass peaks	Bass controls too high, poor quality 100V line loudspeaker transformers. See also No.4 above.
6	Sound distorted and low	Incorrect choice of input module, incorrect module sensitivity setting or pin selection, incorrect loudspeaker load, partial loudspeaker line short, output transformer short circuit, master control set too low.
7	Case gets very hot	Incorrect (excess) loudspeaker loadings, see page 18, parasitic oscillation (usually accompanied by soft hum and mild distortion and appears and disappears at a certain treble control setting) see 8 below, insufficient ventilation, see page 31
8	Parasitic/supersonic oscillation	Insufficient screening on high sensitivity input signal cables, insufficient earthing, loudspeaker/input leads adjacent or parallel for some length, unloaded input line, incoming parasitic on signal line from ancillary equipment, braiding on input cable disconnected or intermittently faulty.
9	Soft hum - volume controls down	Earth/hum loop - see page 25, power supply capacitor failing, induced magnetic field from nearby mains equipment.
10	Hum	Incoming hum from ancillary equipment, induced hum on sensitive input cables, incorrect earthing to amplifier or ancillary equipment, earth/hum loop, see page 25
11	Hiss	Excess treble, signal noise incoming from ancillary equipment, unloaded input signal line, noisy input module.
12	Fizz	Interference from lighting dimmers, dimmer lines, faulty fluorescent lights, earth/hum loop, see page 25
13	Loud harsh hum	Disconnected signal input braiding, or buzz earth/hum loop, see page 25
14	Intermittent loud cracking	Strained input module edge connectors, dirty edge connectors, intermittent input lead connections, dirty voltage selector pins, dirty mains plug pins, loose mains fuse, radiated interference from thermostat etc. see also No.5 above.
15	Howling or ringing and booming	Acoustic feedback between microphone and loudspeakers
16	DC fuses blowing	Failed output transistors and/or driver board
17	Mains line fuse blowing	Mains switch suppressor shorted, main rectifier failed, mains transformer failed, output transistors failed
18	Input channel off	Incorrect priority triggering, module edge connector, module muted by higher priority, input signal fault, module not set to passive mode
19	Incorrect signal priority	Incorrect setting of PCB priority switches or of priority/passive jumpers
20	Intermittent sound	Strained input module or driver board edge connector, fractured input cable, worn volume control track.
21	Mixer AC supply fuse blowing	Regulator module
22	Power switch unlit	AC (and/or DC) power missing, switch lamp, internal lamp regulator, power fuses.
23	ERROR lamp flashing infrequently	Signal bass peaks triggering protection infrequently circuitry
24	ERROR lamp flashing frequently	Loudspeaker load excessive, or faulty threshold frequently setting.
25	ERROR lamp on permanently, no audio output	Faulty power section module.
26	Rhythmic clicking	Incompatibility of internal charging system and earthing in multi-amplifier installation, red wire on Power Management PCB not disconnected

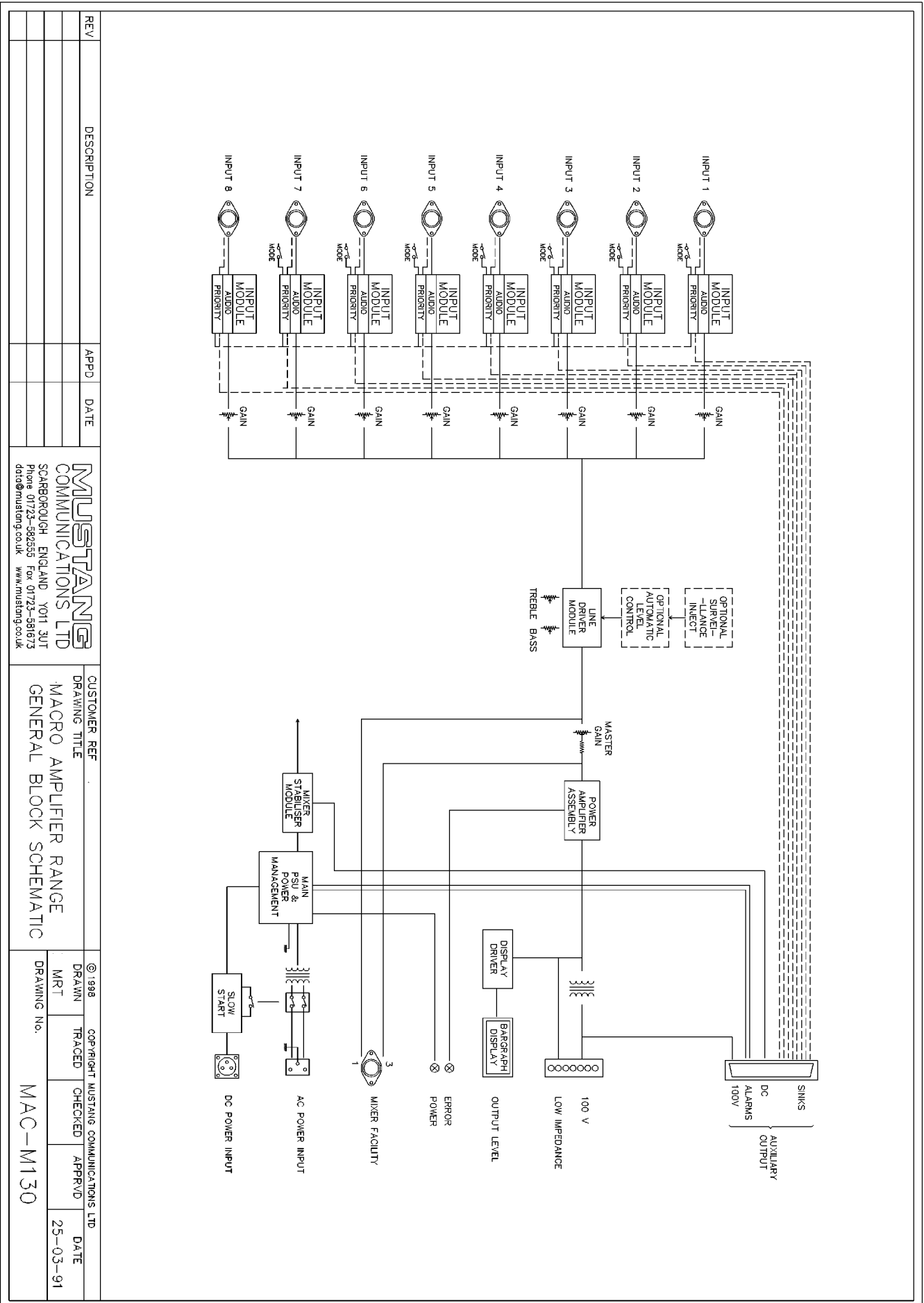

REV	DESCRIPTION	APPD	DATE

MUSTANG COMMUNICATIONS LTD
 SCARBOROUGH ENGLAND YO11 3UT
 Phone 01723-582555 Fax 01723-581673
 data@mustang.co.uk www.mustang.co.uk

CUSTOMER REF
 DRAWING TITLE
MACRO AMPLIFIER RANGE
GENERAL BLOCK SCHEMATIC

© 1998	COPYRIGHT MUSTANG COMMUNICATIONS LTD		
DRAWN	TRACED	CHECKED	APPVD
MRT			
DRAWING No.	DATE		
MAC-M130	25-03-91		

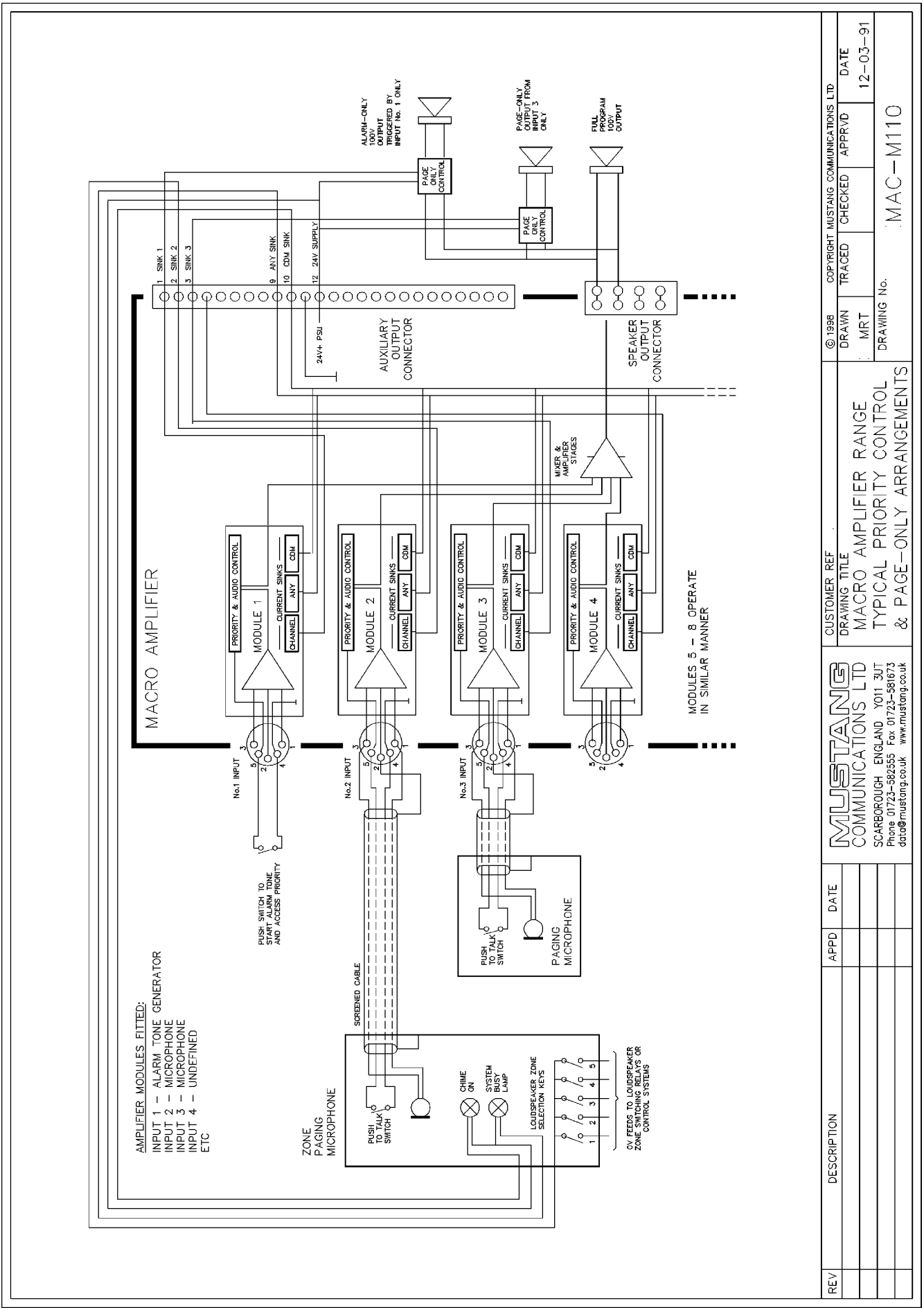

REV	DESCRIPTION	APPD	DATE	MUSTANG COMMUNICATIONS LTD SCARBOROUGH ENGLAND YO11 3UT Phone 01723-582555 Fax 01723-581673 data@mustang.co.uk www.mustang.co.uk	
				CUSTOMER REF DRAWING TITLE MACRO AMPLIFIER RANGE TYPICAL PRIORITY CONTROL & PAGE-ONLY ARRANGEMENTS	
				© 1998 COPYRIGHT MUSTANG COMMUNICATIONS LTD DRAWN MRT TRACED	CHECKED APPROVD DATE 12-03-91
				DRAWING No. MAC-M110	

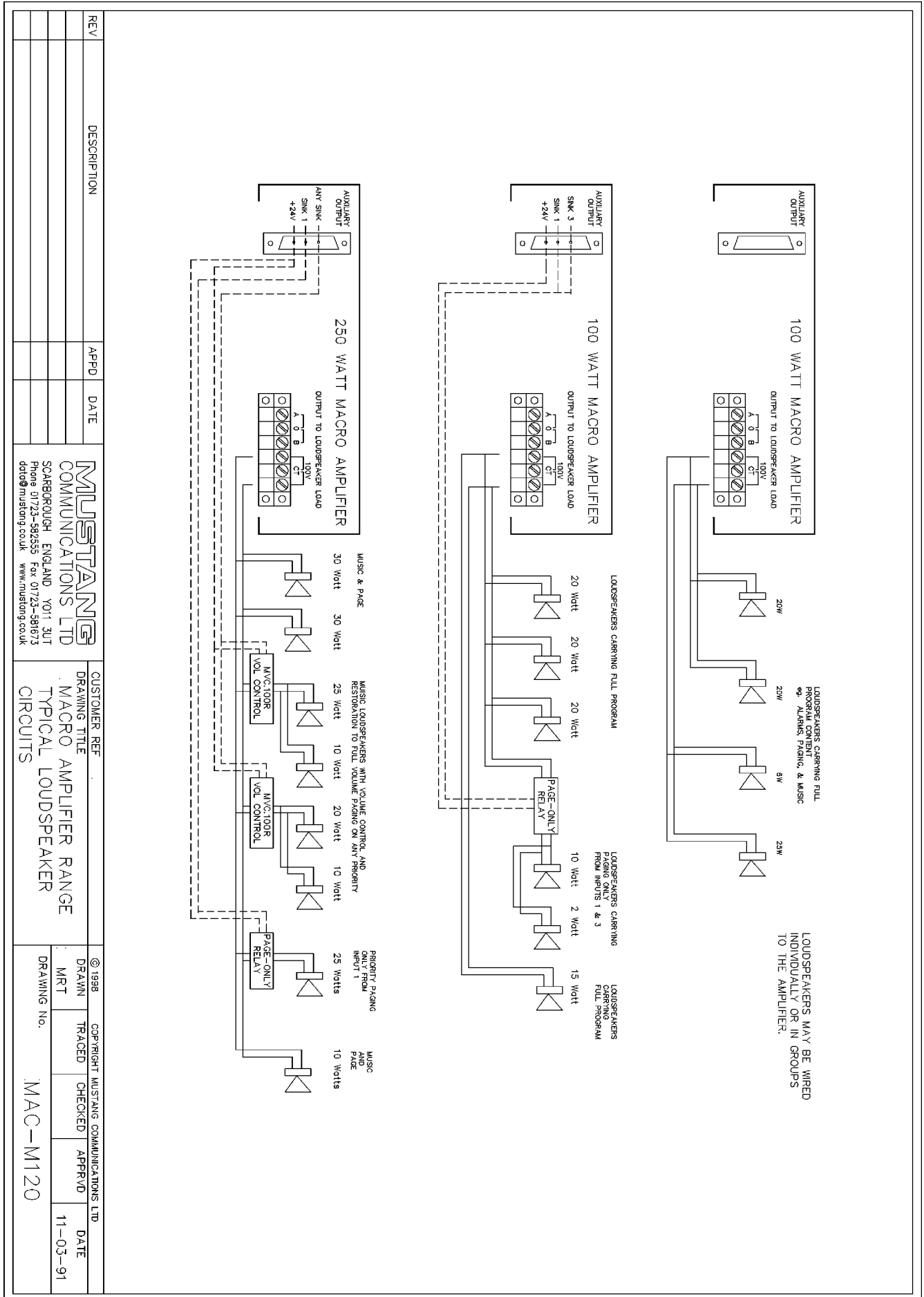

REV	DESCRIPTION	APPD	DATE	CUSTOMER REF	©1998	COPYRIGHT MUSTANG COMMUNICATIONS LTD.			
				DRAWING TITLE	DRAWN	TRACED	CHECKED	APPVD	DATE
				MUSTANG COMMUNICATIONS LTD	MRT				11-03-91
				SCARBOROUGH ENGLAND Y01 3UT	DRAWING No. MAC-M120				
				Phone 01723-582555 Fax 01723-581673					
				ddc@mustang.co.uk www.mustang.co.uk					

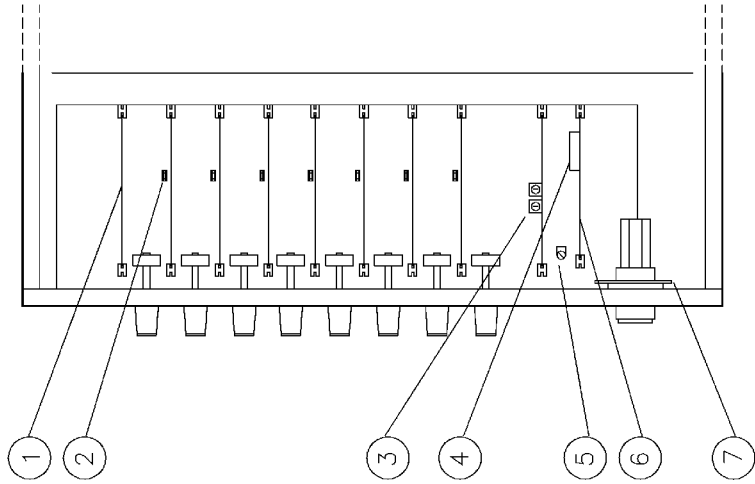

PRE-AMPLIFICATION SECTION

- 1 INPUT MODULE No.1
- 2 EQUAL ACCESS PRIORITY SWITCH INPUTS FOR INPUTS 1-2
- 3 TREBLE (ON RIGHT) & BASS CONTROLS
- 4 PRE-AMPLIFIER & AUX DC FUSES
- 5 MASTER GAIN CONTROL
- 6 POWER SUPPLY STABILISER MODULE

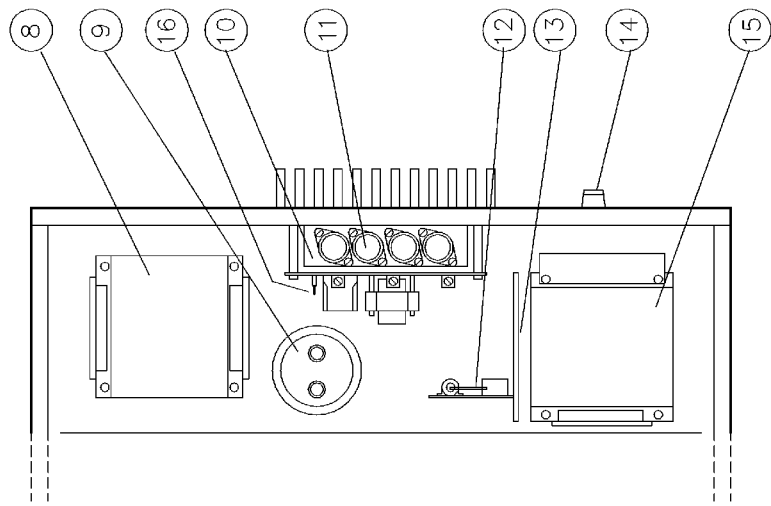

100 & 250 WATT POWER SECTION

- 7 DISPLAY PCB
- 8 OUTPUT TRANSFORMER
- 9 MAIN DC SUPPLY CAPACITOR
- 10 POWER AMPLIFIER OUTPUT MODULE
- 11 OUTPUT TRANSISTORS
- 12 BATTERY CHARGER 'RED' LINK
- 13 POWER MANAGEMENT PCB
- 14 AC AND DC INPUT SUPPLY FUSES
- 15 MAINS TRANSFORMER
- 16 SPECIAL FUSIBLE LINK

REV	DESCRIPTION	APPD	DATE	CUSTOMER REF DRAWING TITLE MACRO AMPLIFIER RANGE MAIN COMPONENT IDENTIFICATION		© 1998 COPYRIGHT MUSTANG COMMUNICATIONS LTD DRAWN MRT	TRACED CHECKED APPROVD	DATE 11-03-91
				MUSTANG COMMUNICATIONS LTD SCARBOROUGH ENGLAND YO11 3UT Phone 01723-582555 Fax 01723-581673 data@mustang.co.uk www.mustang.co.uk		DRAWING No. MAC-M100		

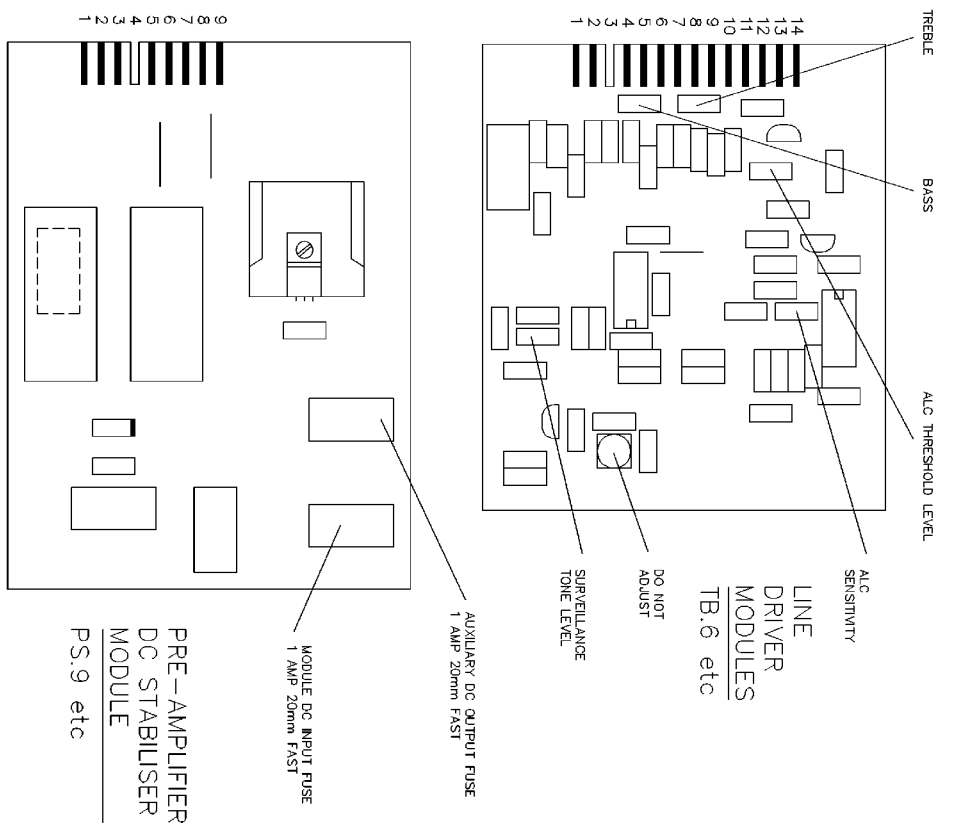
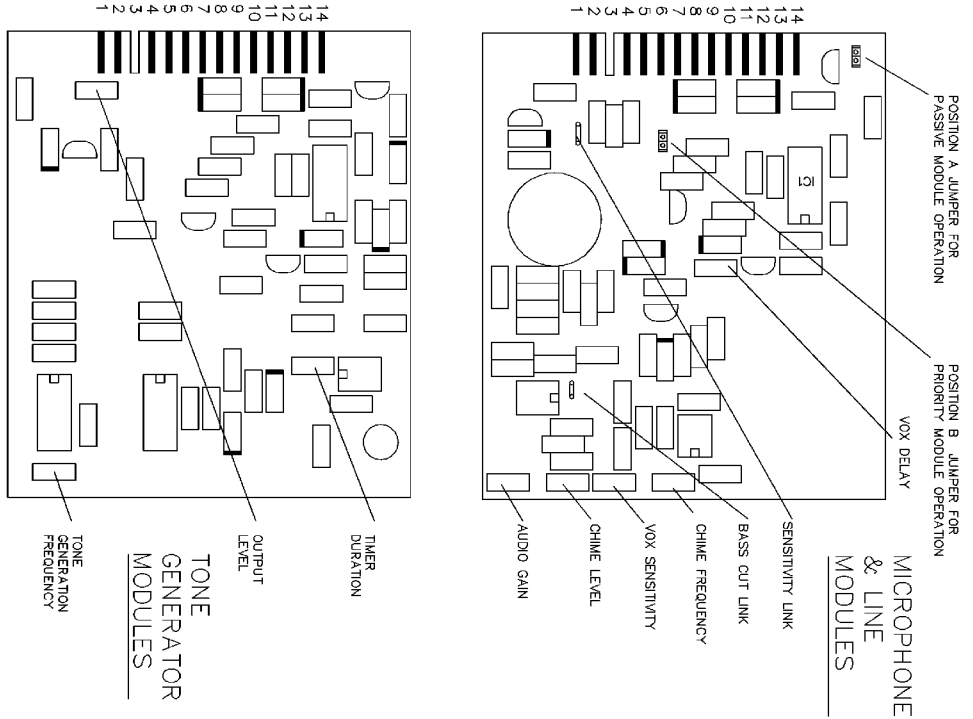

NOTE: FEATURES AND ADJUSTMENTS FITTED DEPEND UPON EXACT MODULE TYPE

VIEW FROM COMPONENT SIDE

REV	DESCRIPTION	APPD	DATE

MUSTANG COMMUNICATIONS LTD SCARBOROUGH, ENGLAND, YO11 3JT Phone 01723-582335 Fax 01723-581673 dtd@mustang.co.uk www.mustang.co.uk		CUSTOMER REF DRAWING TITLE MACRO AMPLIFIER RANGE LOCATION OF MODULE ADJUSTMENTS & FUSES	©1998 COPYRIGHT MUSTANG COMMUNICATIONS LTD DRAWN TRAGED MRT DRAWING No.	DATE 25-03-91
---	--	---	--	------------------

MAC-M140