



Clever Features, Contractor Friendly

IS600

IS1200

Stereo Professional Audio Amplifiers



Installation

&

Operation Manual

Introduction

The Australian Monitor Installation Series **IS600** & **IS1200** are 2 RU stereo power amplifiers. The **IS600** delivers 300 watts per channel @ 4 ohms & the **IS1200** delivers 600 watts per channel @ 4 ohms. Designed for permanent installations where high quality audio reproduction is required on a small budget, the **IS** series deliver the sound quality & features contractors require. The **IS** series continues the Australian Monitor tradition of delivering an amplifier packed with clever features at a contractor friendly price.

| | |
|---|---|
|  <p>CAUTION RISK OF ELECTRIC SHOCK DO NOT OPEN</p> <p>CAUTION: TO REDUCE THE RISK OF ELECTRIC SHOCK. DO NOT REMOVE COVER (OR BACK). NO USER-SERVICEABLE PARTS INSIDE. REFER SERVICING TO QUALIFIED SERVICE PERSONNEL.</p> |  <p>This symbol is intended to alert the user to the presence of uninsulated "dangerous voltage" within the product's enclosure that may be of sufficient magnitude to constitute a risk of electric shock to persons.</p> |
| <p>WARNING !</p> <p>TO REDUCE THE RISK OF FIRE OR ELECTRIC SHOCK. DO NOT EXPOSE THIS EQUIPMENT TO RAIN OR MOISTURE.</p> |  <p>This symbol is intended to alert the user to the presence of important operation and maintenance (servicing) instructions in the literature accompanying the appliance.</p> |
| | <p>Caution: To prevent electric shock do not use this (polarized) plug with an extension cord, receptacle or other outlet unless the blades can be fully inserted to prevent blade exposure.</p> |
| | <p>To prevent electric shock, match wide blade of plug to wide slot, fully insert.</p> |

Features

- Custom 2RU design.
- High efficiency toroidal mains transformer.
- Binding post and 4 pole speaker output connection.
- Stereo or Parallel operation.
- Balanced inputs and buffered attenuators.
- Signal Present indication.
- Output clip indication.
- Efficient front to back cooling.
- Twin speed axial fans.
- Thermal fault indication.
- Signal ground lift switch.

Protection Features

- Short circuit protection.
- Overload protection.
- Soft Start.
- Thermal protection.

Contents

| | | |
|--------------------------------------|------|----|
| | Page | |
| 1. Introduction | 2 | |
| 2. Controls, Connectors & Indicators | | 5 |
| 2.1 Front Panel | 5 | |
| 2.2 Rear Panel | 7 | |
| 3. Installation | 9 | |
| 4. Operation | 11 | |
| 5. Maintenance | | 14 |
| 6. Specifications | 15 | |

IMPORTANT!

Please read carefully.

This operation manual contains important information regarding safety precautions, installation, performance, operation and maintenance of your **IS-Series** power amplifier. You should familiarize yourself with the contents of this manual **before** operating your amplifier

The user should not attempt to service the amplifier. Only qualified and knowledgeable personnel familiar with the internal workings of the amplifier should attempt any repair, servicing or authorized modification to the amplifier. The amplifier does not contain any parts which the user can service or re-use in this or any other product.

If you are in need of special assistance and the information you require is outside the scope of this manual, please contact your nearest service agent or Australian Monitor direct:

THE TECHNICAL OFFICER
AUSTRALIAN MONITOR
C/- AUDIO TELEX COMMUNICATIONS PTY LTD
PRIVATE BAG 149,
SILVERWATER. N.S.W. 1811
AUSTRALIA.

| | | |
|---------------|----------------|----------------|
| | Phone | Fax |
| Australia | (02) 9647-1411 | (02) 9748-2537 |
| International | 61-2-9647-1411 | 61-2-9748-2537 |

Email ho@audiotelex.com.au
Internet www.australianmonitor.com.au

Front Panel

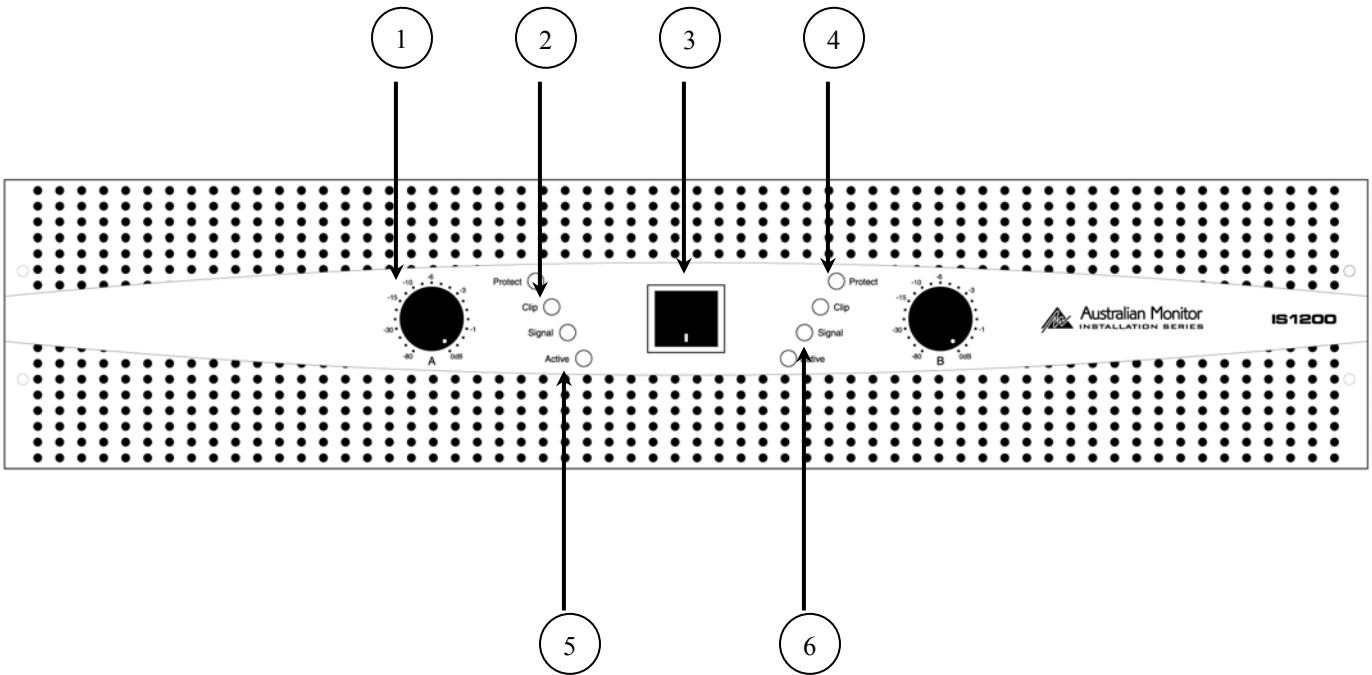

1 Attenuator

There are 2 level controls on all **IS** models. Each control is labelled for the channel which it controls. 0dB indicates minimum attenuation.

2 Clip Indicator

This LED displays the status of the output stage and displays two levels of operation.

These levels are:

Below clip level (unlit)
Clipping & above (**red**)

The LED will change to red once the output exceeds the clipping point of the amplifier's output stage. The threshold is referred to the amplifier supply rails and alters with changes in the mains supply, changes in the load and duty cycle fluctuations.

The attack and decay time (ballistics) of the status circuit are those of a Peak Programme Meter (P.P.M.)

NOTE: The amplifier is not damaged by running into clipping, **but speakers may be**. To maximise the life of your speakers, try to keep clipping infrequent.

3 Power Switch

This switches AC power to the amplifier. Press the switch to **up** for power **on** and **down** for power **off**. At start-up (turn-on), the input to the amplifier is muted for approximately two seconds.

4 Protect Indicator

This **red** LED will illuminate when thermal shutdown occurs.

5 Active Indicator

This LED will illuminate **blue** and indicates that the amplifier is **ON** and receiving AC mains power.

6 Signal Indicator.

This LED displays the status of the output stage and varies in intensity in proportion to the output signal level.

Rear Panel

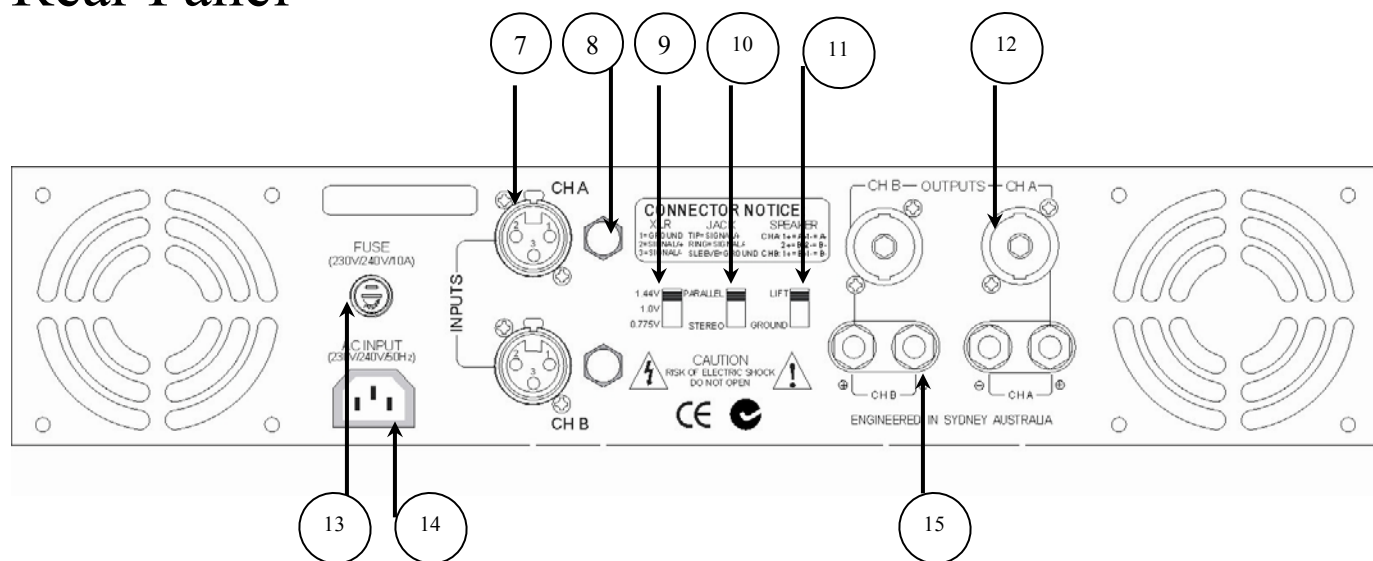

7 Balanced XLR Input

A female 3-pin XLR type connector is provided for each input:

Pin 1 = Signal Ground;

Pin 2 = Hot (non-inverting or in phase);

Pin 3 = Cold (inverting or reverse phase).

8 Balanced 6.35mm TRS Input

A female 6.35mm TRS connector is provided for each input.

Tip = Hot (non-inverting or in phase);

Ring = Cold (inverting or reverse phase);

Sleeve = Signal Ground.

9 Input Sensitivity Switch

This switch allows the amplifiers input sensitivity to be correctly matched to the equipment providing the amplifiers input signal. See the Operation section (page 12) for more details.

10 Parallel/Stereo Switch

This switch determines whether channels A & B are receiving separate signals (i.e. Operating in stereo mode) or whether the input signal from channel A is being fed through to channel B.

Note: This is not Bridge mode.

11 Ground Lift Switch

When this switch is engaged, it disconnects signal ground from the input connectors on both channels. It is intended to be used when “hum” is caused by earth loops (due to different ground potentials between source equipment and the amplifier) or stray magnetic field pick up on the input ground/shield wiring. **The amplifier should be turned off before engaging this switch!**

12 Speaker Output Connector

A 4 pole speaker connector is provided as an additional speaker output. This standard of loudspeaker-to-amplifier connection allows access to both channels of the amplifier via the one connector for bi-amp applications. Channel-A is considered the dominant channel and has both channels wired to the speaker connector. See the installation section of this manual for detailed information on speaker connector wiring.

13 Mains Fuse

The IS600 is fitted with a 8 amp slow blow fuse & the IS1200 is fitted with a 15 amp slow blow fuse.

14 Mains Connection

Your amplifier is fitted with an internationally recognised IEC mains inlet connector. Please ensure that the connecting mains lead for use with the IEC connector is of an approved type and is of sufficient current carrying capacity.

NOTE: Your unit must always be earthed!

15 Binding Post Outputs

Touch-proof binding posts (banana jacks) are provided for speaker output termination with banana plugs or bare wire. The red post is used as **positive** and the black post is used as **negative**.

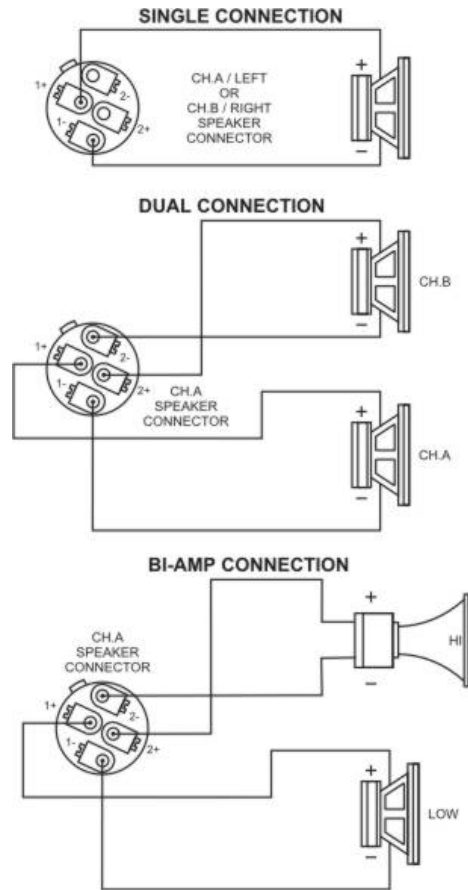

Installation

Power Requirements

Ensure that **your** mains voltage is the same as the rear panel mains voltage marker (+/- 10%).

Mounting

Your amplifier is designed for standard 19" rack mounting and occupies 2 EIA rack units.

Cooling

Each channel of your **IS** Series amplifier is cooled by an axial fan which draws cool air from the front of the amplifier and expels heated air out the rear of the amplifier. These amplifiers include two-speed fans which normally run at half speed, switching to full speed when the internal heatsink temperature exceeds 50°C. **An unrestricted airflow into and out of the amplifier must be provided.** Any restriction of the air flow will cause heat to build up within the amplifier and possibly force the amplifier into its thermal shutdown mode. If

the amplifiers are to be operated in an environment where the airflow is restricted, such as sealed racks, cooling should be supplemented by extra cooling fans to evacuate the heated air and aid the flow of cool air through the amplifier.

Input Wiring

IMPORTANT

Do not directly connect pin 1 on the amplifier's input XLR or TRS jack, to the amplifier's chassis, speaker ground or power ground!

NOTE: Input signal ground is not to be used as a safety ground (earth).

The input to your amplifier is a balanced 3-pin configuration and requires all three pins to be connected. Only high quality twin-core shielded cable should be used. When wiring for a balanced source, the connector going to the input of your amplifier should be wired as follows:

Pin 1 = GROUND / SHIELD.

Pin 2 = HOT (In Phase - non inverting).

Pin 3 = COLD (Reverse Phase - inverting).

When wiring for an unbalanced source you **must** ensure that pin 3 is connected to pin 1 (input ground), either by linking the pins in the input connector or by the source equipment's output wiring.

When wiring for an unbalanced source:

Pin 1 = GROUND/SHIELD

Pin 2 = HOT (in phase with the amplifier's output),

Pin 3 = GROUND/SHIELD (joins to pin 1).

NOTE:

In-line XLR connectors often have a termination lug that connects directly to the chassis of the connector. Do **not** link this lug to pin 1 at the amplifier's input as it will defeat the amplifier's input grounding scheme. This lug is often referred to as a "drain" and is used to provide a termination to the chassis for shielding purposes when a floating signal ground is required between the source and destination, or when disconnecting the signal ground is required to reduce earth loop noise, or noise induced into signal grounds from stray magnetic fields.

Output Wiring

When wiring to your speakers, always use the largest gauge wire your connector will accept. The longer the speaker lead, the greater the losses will be, resulting in reduced power and less damping at the load. We recommend using a heavy-duty, two core flex (four core flex if bi-amping) 10 to 12 gauge (2mm² to 2.5mm² or 50/0.25 or equivalent) as a minimum.

Binding Post Outputs

When terminating to the 4 mm binding post (banana jack) output connectors, banana plugs or bare wires can be used. The red terminal is **positive** and the black terminal is **negative** (ground).

Speaker Outputs

When using the 4 pole speaker connector for speaker output, use only the mating 4 pole in-line connector. This connector is designed so that both speakers can be fed from a single connector. Two speaker connectors are provided on the amplifier. The "Channel A" speaker connector actually carries both channel A & Channel B outputs (see: Speaker Connector Wiring Diagrams). The "Channel B" speaker connector carries the Channel B output only. This arrangement allows you the option of connecting to the outputs separately or together. Connecting through a single connector has the advantage of minimising connections, preserving phasing and simplifying channel allocation, which is particularly important when **bi-amping**.

IMPORTANT

Do not overload your amplifier by connecting the channel B output twice!

Channel A is used as the "dominant" channel and when sourcing a dual output from Channel A, the following standard should be used:

Channel A = Left or Low Frequencies.

Channel B = Right or High Frequencies.

Operation

IMPORTANT

All signal source equipment should be adequately earthed. This not only ensures **your** safety, but everybody else's as well. Faults can and do occur in mains connected equipment where the chassis can become "live" if it is not properly earthed. In these instances, the fault in a "floating" (ungrounded) piece of equipment will look for the shortest path to ground, which could possibly be your amplifier's input. If the fault current is large enough, it will destroy the input to your amplifier and look for the next available path, which **may be you!**

Before making any connections to your **IS** Series amplifier, observe the following:

Ensure the mains voltage supply matches the label on the rear panel of your amplifier (+/- 10%).

Ensure that the power switch is **OFF**.

Ensure that all system grounds (earth) are connected from a common point. Avoid powering equipment within a system from multiple power sources that may be separated by large distances.

Check the continuity of all interconnecting leads to your amplifier; ensure that there are no open or short circuited conductors.

Ensure that the power handling of your load (speakers) can adequately cope with the power output of the amplifier.

Before operating your **IS** Series amplifier, ensure that:

- The attenuators are at the "OFF" position (fully anticlockwise).
- The GROUND LIFT Switch is not engaged (should be in the "Ground" position).

Powering Up

REMEMBER

The amplifier should be the **last** piece of equipment that you turn **on** and the **first** piece of equipment that you turn **off**.

We recommend turning the attenuators on your amplifier **down** when turning the unit on. When you power up your **IS** Series, your amplifier goes through an initialising period before it will accept signal. The Inrush Current Suppression (ICS) circuit is in operation for the first 0.5 seconds. This limits the mains current, to prevent "nuisance-tripping" of circuit breakers. During this period you will hear a couple of relays "click", indicating mains is now directly applied to the amplifier and the signal path is connected. While the ICS circuit operates there is also a 30dB mute on the signal input. After two seconds this mute will release, allowing any applied signal to pass un-attenuated. When switching the amplifier off, **wait** a couple of seconds before switching the amplifier on again. This allows the ICS circuit to reset.

Level Matching

The normal operating position for the attenuator is the maximum position (fully clockwise, no attenuation). In this position the amplifier operates at full gain. Turning the attenuator down (anticlockwise) reduces the input sensitivity.

NOTE:

If full power output is required, you should operate your amplifier with the front panel attenuator above the half way (12o'clock) position, otherwise clipping of the input circuitry (and its resultant distortion) will occur before full output power is achieved.

Sensitivity

Your amplifier is a linear device operating with a fixed input to output voltage gain (less attenuation). The maximum output voltage swing is determined by the applied mains voltage, load, load type and the duty cycle of the applied signal. The **input sensitivity** for your **IS** Series amplifier when the attenuator is at maximum position (fully clockwise) is determined by the Input Sensitivity switch.

There are 3 settings for rated power into a 4 ohm load.

0.775V in for rated power out

1.0V in for rated power out

1.44 V in for rated power out.

Each channel of your **IS** Series amplifier has a nominal balanced **input impedance** of 20kOhms (@1kHz) and should not present a difficult load for any signal source. (i.e. the equipment feeding signal).

Hum Problems

Most equipment is designed for minimum hum when used under ideal conditions. When connected to other equipment and to a safety earth in an electrically noisy environment, problems may occur. The three "E"s of hum and hum related noise which can plague your audio system are:

- a) Electrostatic radiation,
- b) Electromagnetic radiation, and
- c) Earth loops

Electrostatic radiation capacitively couples to system elements, causing an interference voltage that mainly affects higher impedance paths, such as amplifier inputs. The source is generally a nearby high voltage, such as a mains lead or a speaker lead. The problem can usually be reduced by moving the offending lead away, or by providing additional electrostatic shielding (i.e. an earthed conductor which forms a barrier to the field).

Electromagnetic radiation induces interference currents into system elements that mainly effect lower impedance paths. Radio transmitters or stray magnetic fields from mains transformers are often the cause of this problem. It is generally more difficult to eliminate this kind of interference, but again, moving the source away or providing a magnetic shield (i.e. a steel shield) should help.

Earth loops can arise from the connection of the various pieces of equipment and their connections to various safety earths. This is by far the most common cause of hum and it occurs when source equipment and the amplifier are plugged into different points along the safety earth where the safety earth wiring has a current flowing through it. The current flowing through the wire produces a voltage drop due to the wire's resistance. This voltage difference between the amp earth and source equipment earth appears to the amplifier's input as a signal and is amplified as hum.

There are three things you can do to avoid earth loop problems:

1. Ensure the mains power for the audio system is "quiet" i.e. without equipment on it such as air-conditioning, refrigeration or lighting which may generate noise in the earth circuit.
2. Ensure all equipment within the system shares a common ground/ safety earth point. This will reduce the possibility of circulating earth currents, as the equipment will be referenced to the same ground potential.
3. Ensure that balanced signal leads connecting to the amplifier are connected to earth at one end only.

Signal Ground-Lift Switch

When proper system hook-up has been made, you may still have some hum or hum related noise. This may be due to any of the previously mentioned gremlins. Your **IS** Series amplifier has a "Signal Ground Lift" switch which disconnects the input ground wiring from the amplifier. A substantial drop in hum and/or hum related noise can result from the judicious use of this switch.

NOTE:

If the input ground lift switch is used, you must ensure adequate shielding of the input wiring. If the signal source equipment does not provide adequate shielding (i.e. a definitive connection to ground), you must disconnect the shield from the input connector's ground pin (Pin-1) and re-connect it to the "drain" contact on the input connector. This will ensure the shield on your input wiring actually goes to the amplifier chassis and subsequently to earth.

DO NOT CONNECT PIN-1 DIRECTLY TO THE DRAIN CONNECTION.

You will defeat the amplifiers internal grounding scheme and possibly cause instability in the amplifier. Always ensure that your amplifier is **off** and the attenuators are **down** when you engage this switch. This switch should only be used when the amplifier is operated from a **balanced** signal source.

NOTE:

Be wary of **quasi-balanced** outputs, these are often no more than floating **unbalanced** outputs.

Maintenance



Only **competent qualified** persons should attempt any service or maintenance of your amplifier. Your **IS** Series amplifier will need minimal maintenance. No internal adjustments need to be made to the unit to maintain optimum performance. To provide years of unhindered operation we suggest a maintenance inspection be carried out on a regular basis, say every 12 months or so.

NOTE:

The following instructions are intended for action by **qualified personnel only**.

Fans

Due to the openness of the air path through your IS Series amplifier, very little dust should settle within the amplifier. The unit has been designed so that any dust and/or foreign particles that do settle within the amplifier will not unduly hinder the cooling of the amplifier. The grille in front of the fans will act to limit the amount of dust and lint entering the amplifier. You will find that in time there will be a build up of dust and lint on the grille which may hinder the airflow through the amplifier. You should periodically remove the dust and keep the grille clean. Removal of dust from the rear grille will also aid cooling. Over time, dust may build up on the leading edge of the fan blades and reduce their cooling efficiency. The time taken for this to happen will depend on the environment and the amount of use. The fan blades are accessible once the lids are removed and can be easily cleaned. You need only hold the fan rotor still and wipe the dust off the blades. Many users **stall** the fan and use compressed air to blow the dust off the fan blades. It is important to note that the fan blades must be held still whilst blowing air over the blades otherwise you may burn out the bearings in the fan.

Fuses

Along with a rear panel mains fuse, there are four (4) internal rail fuses in the unit. These rail fuses are in series with the positive and negative output supply to each amplifier channel and provide overall protection for the output stage. If the amplifier is subjected to heavy use such as short circuits, these fuses will eventually fatigue and may require replacing to ensure they do not fail at an inconvenient time.

NOTE



Make sure the unit is **off** and is unplugged from the mains. Give the main filter capacitors time to discharge before removing lids and inspecting the fuses.

You should replace the fuse if the element is **sagging or discoloured**. Only ever replace with the same type fuse and current rating.

When checking for a failed fuse, do not rely on visual inspection alone. You should use an ohm meter to check continuity.

IS600 Specifications

| | |
|--------------------|----------------------------------|
| Output @ 8 ohms | 2 x 200 watts |
| Output @ 4 ohms | 2 x 300 watts |
| Frequency Response | <10Hz - >50kHz (-3dB) |
| THD | <0.03% @1 kHz |
| Crosstalk | 60dB |
| Slew Rate | 12.5 v/ms |
| Damping Factor | 250 into 8 ohms/ 125 into 4 ohms |
| Input Impedance | 20Kohm |
| Signal/noise ratio | >99dB 20Hz-20kHz |
| Weight | 16.5KG |
| Dimensions (wxdxh) | 483mm x 452mm x 89mm |

IS1200 Specifications

| | |
|--------------------|----------------------------------|
| Output @ 8 ohms | 2 x 400 watts |
| Output @ 4 ohms | 2 x 600 watts |
| Frequency Response | <10Hz - >50kHz (-3dB) |
| THD | <0.03% @1kHz |
| Crosstalk | 60dB |
| Slew Rate | 12 v/ms |
| Damping Factor | 250 into 8 ohms/ 125 into 4 ohms |
| Input Impedance | 20Kohm |
| Signal/noise ratio | >105dB 20Hz-20kHz |
| Weight | 20.5KG |
| Dimensions (wxdxh) | 483mm x 452mm x 89mm |

AUSTRALIA and NEW ZEALAND

www.australianmonitor.com.au

Sydney

(NSW & ACT Sales)

Private Bag 149, Silverwater NSW 1811
149 Beaconsfield Street, Silverwater NSW 2128
Ph: (02) 9647 1411
Fax: (02) 9648 3698
E-mail: nsw@audiotelx.com.au

Brisbane

(Qld Sales)

P.O. Box 871, Fortitude Valley QLD 4006
42 Commercial Road, Fortitude Valley QLD 4006
Ph: (07) 3852 1312
Fax: (07) 3252 1237
E-mail: qld@audiotelx.com.au

Perth

(WA Sales)

P.O. Box 404, North Perth WA 6906
299 Fitzgerald Street, West Perth WA 6005
Ph: (08) 9228 4222
Fax: (08) 9228 4233
E-mail: wa@audiotelx.com.au

Melbourne

(Vic & Tas Sales)

P.O. Box 131, Blackburn South VIC 3130
22/277 Middleborough Road, Box Hill VIC 3128
Ph: (03) 9890 7477
Fax: (03) 9890 7977
E-mail: vic@audiotelx.com.au

Adelaide

(SA & NT Sales)

P.O. Box 157, Hindmarsh SA 5001
31 Walsh Street, Thebarton SA 5031
Ph: (08) 8352 4444
Fax: (08) 8352 4488
E-mail: sa@audiotelx.com.au

Auckland

(NZ Sales)

P.O. Box 512, Albany 1331
Unit B, 11 Piermark Drive, Albany 1331
Ph: (09) 415 9426
Fax: (09) 415 9894
E-mail: audiotlx@nznet.gen.nz

EUROPE/ASIA/MIDDLE EAST

www.australianmonitor.com.au

International Sales

Private Bag 149, Silverwater NSW 1811
149 Beaconsfield Street, Silverwater NSW 2128
Australia
Ph: 61-2- 9647 1411
Fax: 61-2-9748 2537
E-mail: international@audiotelx.com.au