



# TECHNICAL SERVICE MANUAL

**VIKING** **MAG DRIVE**

MAGNETIC DRIVE PUMPS  
 SERIES 823 - STEEL  
 825 - CAST IRON  
 827 - STAINLESS STEEL  
 SIZES LQ, LS, Q & QS

SECTION	TSM 845.1
PAGE	1 OF 13
ISSUE	C

## CONTENTS

Introduction . . . . .	1
Special Information . . . . .	3
Pressure Relief Valves . . . . .	3
Maintenance . . . . .	3
Disassembly: Pump . . . . .	6
Pump Rotation . . . . .	7
Port Arrangement . . . . .	7
Disassembly: MD-D Series Coupling . . . . .	7
Bearing Housing . . . . .	9
Disassembly of Bearing Housing . . . . .	9
Assembly of Bearing Housing . . . . .	9
Installation of Bushings . . . . .	9
Pump Assembly . . . . .	10
Adjusting Head Gasket End Clearance . . . . .	11
Assembly: D Series Coupling . . . . .	11
Troubleshooting . . . . .	12
Pressure Relief Valves . . . . .	12
Pressure Adjustment . . . . .	12
Disassembly: Relief Valve . . . . .	13
Assembly: Relief Valve . . . . .	13

## INTRODUCTION

The illustrations used in this manual are for identification purposes only and should not be used for ordering parts. Secure a parts list from the factory or a Viking® representative. Always give the complete name of the part, model and serial number of the pump when ordering repair parts. The pump model and serial number can be found on the nameplate secured to the pump.

In the Viking model number system, the basic size letters are combined with series number (825, 823, or 827) indicating basic pump construction material (cast iron, steel or stainless steel).

## MODEL NUMBER CHART

UNMOUNTED PUMP	UNITS
LQ-825, 823, 827	Units are designated by the un-mounted pump model numbers followed by the magnetic coupling size and a letter indicating drive style:
LS-825, 823, 827	
Q-825, 823, 827	B – Bracket Mount R – Viking Reducer Drive P = Commercial Reducer Drive (Example: LS-827 MD-D140 R)
QS-825, 823, 827	

**WARNING !**

**Persons with surgical implants of a metallic or electronic nature should avoid working on pump – especially the inner magnet assembly.**

This manual deals only with Series 825, 823 and 827 magnetic drive pumps and couplings. Refer to Figures 1 through 21 for general configurations and nomenclature used in this manual. Pump specifications and recommendations are listed in Catalog Section 845.

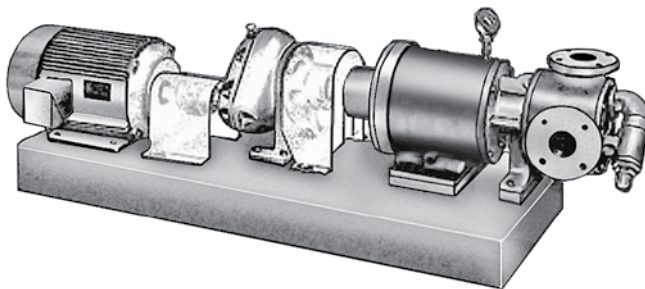

**FIGURE 1**  
**LS-825 MD-D290 R**  
 Complete Unit on Base with Viking "C" Reducer

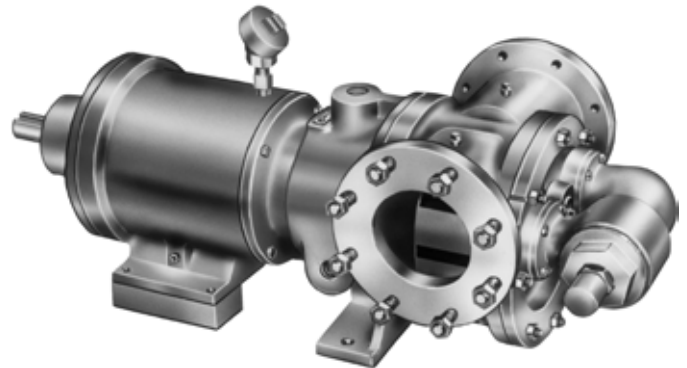

**FIGURE 2**  
**QS-825 MD-D450 B**  
 Bearing Carrier, Footed Pump and Coupling Bracket Jacketed Pump Bracket

# SAFETY INFORMATION AND INSTRUCTIONS

IMPROPER INSTALLATION, OPERATION OR MAINTENANCE OF PUMP MAY CAUSE SERIOUS INJURY OR DEATH AND/OR RESULT IN DAMAGE TO PUMP AND/OR OTHER EQUIPMENT. VIKING'S WARRANTY DOES NOT COVER FAILURE DUE TO IMPROPER INSTALLATION, OPERATION OR MAINTENANCE.

THIS INFORMATION MUST BE FULLY READ BEFORE BEGINNING INSTALLATION, OPERATION OR MAINTENANCE OF PUMP AND MUST BE KEPT WITH PUMP. PUMP MUST BE INSTALLED, OPERATED AND MAINTAINED ONLY BY SUITABLY TRAINED AND QUALIFIED PERSONS.

THE FOLLOWING SAFETY INSTRUCTIONS MUST BE FOLLOWED AND ADHERED TO AT ALL TIMES.

Symbol Legend :



**Danger** - Failure to follow the indicated instruction may result in serious injury or death.

**WARNING**

**Warning** - In addition to possible serious injury or death, failure to follow the indicated instruction may cause damage to pump and/or other equipment.



**BEFORE** opening any liquid chamber (pumping chamber, reservoir, relief valve adjusting cap fitting, etc.) be sure that :

- Any pressure in the chamber has been completely vented through the suction or discharge lines or other appropriate openings or connections.
- The pump drive system means (motor, turbine, engine, etc.) has been "locked out" or otherwise been made non-operational so that it cannot be started while work is being done on the pump.
- You know what material the pump has been handling, have obtained a material safety data sheet (MSDS) for the material, and understand and follow all precautions appropriate for the safe handling of the material.

**WARNING**

**INSTALL** pressure gauges/sensors next to the pump suction and discharge connections to monitor pressures.



**WARNING**

**USE** extreme caution when lifting the pump. Suitable lifting devices should be used when appropriate. Lifting eyes installed on the pump must be used **only** to lift the pump, **not** the pump with drive and/or base plate. If the pump is mounted on a base plate, the base plate must be used for all lifting purposes. If slings are used for lifting, they must be safely and securely attached. For weight of the pump alone (which does not include the drive and/or base plate) refer to the Viking Pump product catalog.



**BEFORE** operating the pump, be sure all drive guards are in place.



**DO NOT** attempt to dismantle a pressure relief valve that has not had the spring pressure relieved or is mounted on a pump that is operating.



**DO NOT** operate pump if the suction or discharge piping is not connected.



**AVOID** contact with hot areas of the pump and/or drive. Certain operating conditions, temperature control devices (jackets, heat-tracing, etc.), improper installation, improper operation, and improper maintenance can all cause high temperatures on the pump and/or drive.



**DO NOT** place fingers into the pumping chamber or its connection ports or into any part of the drive train if there is **any possibility** of the pump shafts being rotated.



**WARNING**

**THE PUMP** must be provided with pressure protection. This may be provided through a relief valve mounted directly on the pump, an in-line pressure relief valve, a torque limiting device, or a rupture disk. If pump rotation may be reversed during operation, pressure protection must be provided on **both** sides of pump. Relief valve adjusting screw caps must always point towards suction side of the pump. If pump rotation is reversed, position of the relief valve must be changed. Pressure relief valves cannot be used to control pump flow or regulate discharge pressure. For additional information, refer to Viking Pump's Technical Service Manual TSM 000 and Engineering Service Bulletin ESB-31.

**WARNING**

**DO NOT** exceed the pumps rated pressure, speed, and temperature, or change the system/duty parameters from those the pump was originally supplied, without confirming its suitability for the new service.



**WARNING**

**BEFORE** operating the pump, be sure that:

- It is clean and free from debris
- all valves in the suction and discharge pipelines are fully opened.
- All piping connected to the pump is fully supported and correctly aligned with the pump.
- Pump rotation is correct for the desired direction of flow.



**WARNING**

**THE PUMP** must be installed in a matter that allows safe access for routine maintenance and for inspection during operation to check for leakage and monitor pump operation.

## SPECIAL INFORMATION

### DANGER !

Before opening any Viking pump liquid chamber (pumping chamber, reservoir, relief valve adjusting cap fitting etc.) Be sure:

1. That any pressure in the chamber has been completely vented through the suction or discharge lines or other appropriate openings or connections.
2. That the driving means (motor, turbine, engine, etc.) has been "locked out" or made non-operational so that it cannot be started while work is being done on pump.
3. That you know what liquid the pump has been handling and the precautions necessary to safely handle the liquid. Obtain a material safety data sheet (MSDS) for the liquid to be sure these precautions are understood.

Failure to follow above listed precautionary measures may result in serious injury or death.

**ROTATION:** Viking Mag Drive® pumps are directional. Shaft rotation determines which port is suction and which is discharge. The port located where pumping elements (gear teeth) come out of mesh is the suction port. Do not attempt to operate the pump in the opposite direction. See **PUMP ROTATION** on page 7.

### PRESSURE RELIEF VALVES:

1. Viking pumps are positive displacement pumps and must be provided with some sort of pressure protection. This may be a relief valve mounted directly on the pump, an inline pressure relief valve, a torque limiting device or a rupture disk. Do not rely on decoupling of magnets for protection from over pressure; this may result in damage to the magnets, pump, or other equipment.
2. If pump rotation is to be reversed during operation, pressure protection must be provided on *both* sides of the pump.
3. The relief valve adjusting screw cap must always point towards the suction side of the pump. Refer to **Figure 3**. If the pump rotation is reversed, remove the pressure relief valve and turn end for end (see **PUMP ROTATION** on **page 7** first for additional steps required for proper operation.)
4. Pressure relief valves cannot be used to control pump flow or regulate discharge pressure.

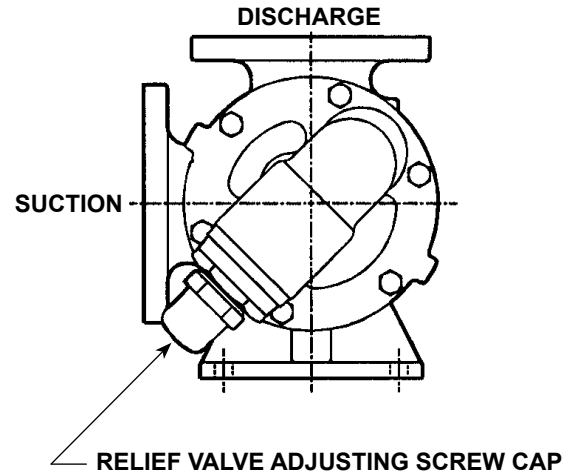

FIGURE 3

For additional information on pressure relief valves, refer to **Technical Service Manual TSM000** and **Engineering Service Bulletin ESB-31**.

## MAINTENANCE

### CAUTION !

Rare earth magnets used in these couplings have extremely strong magnetic fields capable of changing the performance or damaging items such as the following:

**Pacemakers**  
**Metal Implants**  
**Watches**  
**Computers & discs**  
**Credit Cards**

Completely assembled magnetic couplings will not affect items listed above.

Altered performance or damage can occur only when the coupling halves are separated.

There are no known harmful effects of these magnetic fields on the human body.

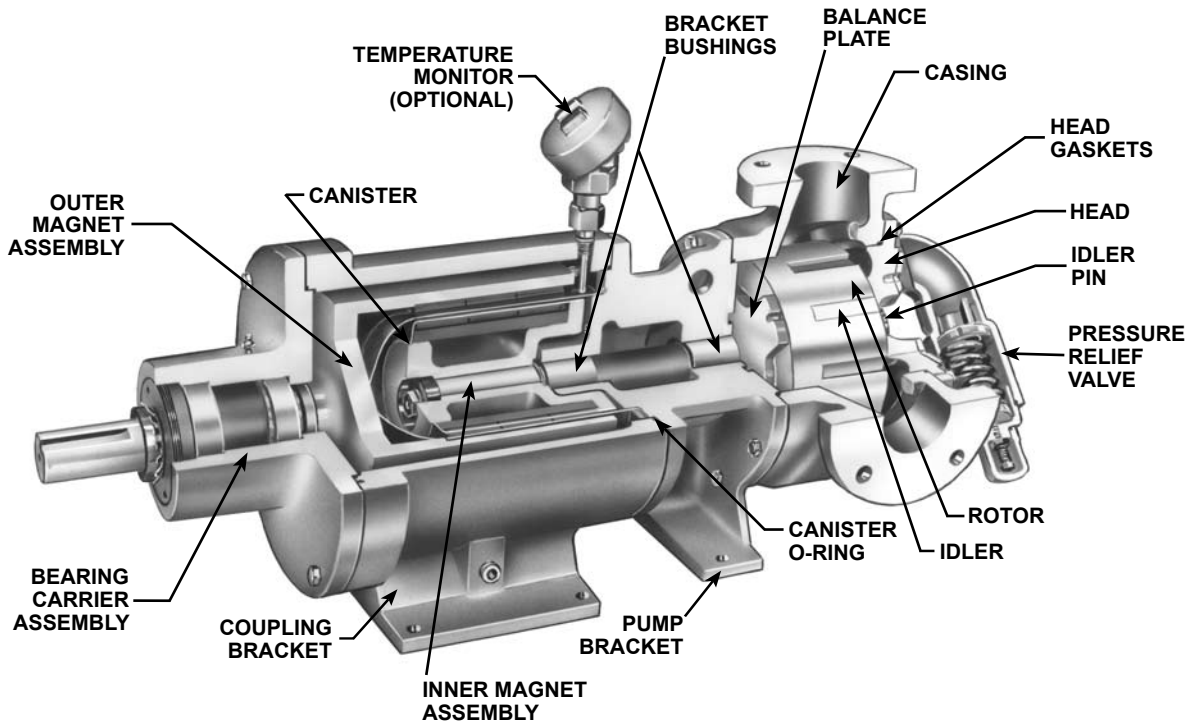

**FIGURE 4**  
**CUTAWAY VIEW MAG DRIVE PUMP, MODEL LS-825 MD-D B ILLUSTRATED**

Series 825, 823, 827 pumps are designed for long, trouble-free service life under a wide variety of application conditions with a minimum of maintenance. The points listed below will help provide long service life.

**CLEANING UNIT:** Keep the pump, coupling and motor as clean as possible. This will facilitate inspection, adjustment, and repair work.

**STORAGE:** If the pump or coupling are to be stored, drain the pump and pour non-detergent SAE 30 weight oil into the pump port. Apply grease to the pump or the coupling shaft extension, if present or accessible. Viking suggests rotating the pump shaft every 30 days to circulate the oil in the pump. The coupling should be stored in a dry area. **Note: if the liquid to be pumped reacts with oil, use an acceptable alternate.**

**SUGGESTED REPAIR TOOLS:** The following tools are required to properly repair a Mag Drive pump. These tools are in addition to standard mechanics tools such as open end wrenches, socket set, pliers, screw drivers, etc. Most items can be obtained from an industrial supply house.

1. Soft headed hammer
2. Allen wrenches
3. Spanner wrench, adjustable pin type for use on end cap (Source: #482 J.H. Williams & Co. or equal)

4. Snap ring pliers (heavy duty) EXTERNAL 2-810-029-375
5. Bearing locknut spanner wrench (Source: #471 J.H. Williams & Co. or equal)
6. Arbor press
7. Feeler gauge set
8. Bearing housing jack screws (2 required) (Supplied with coupling 2-297-022-999)
9. Brass bar

**DANGER !**

**Follow recommended procedures to assemble or disassemble magnetic couplings.**

**Failure to do so may result in serious injury.**

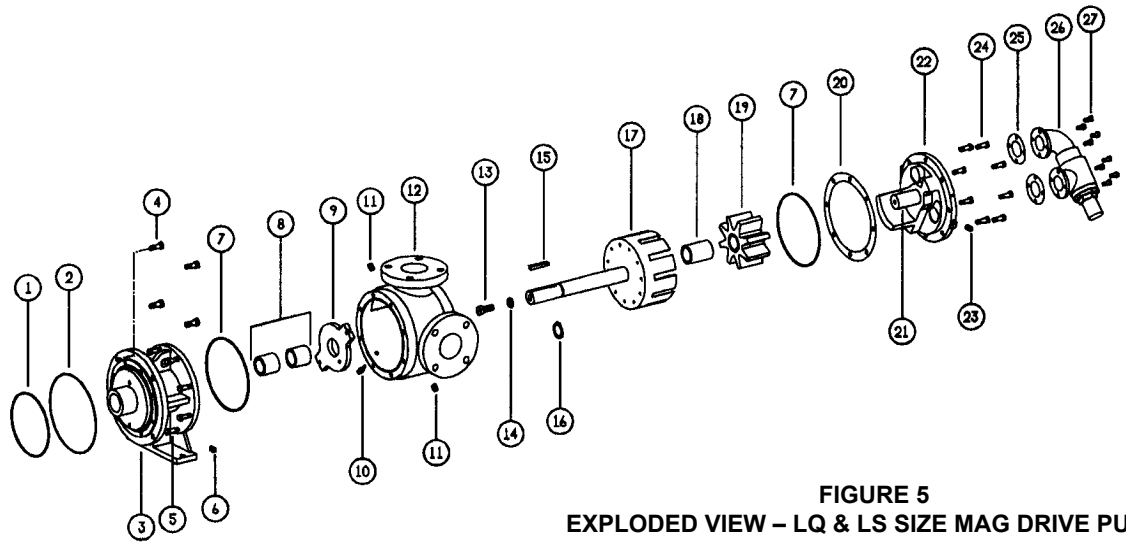

**FIGURE 5  
EXPLODED VIEW – LQ & LS SIZE MAG DRIVE PUMPS**

ITEM	DESCRIPTION	ITEM	DESCRIPTION	ITEM	DESCRIPTION
1	Brkt Gasket - Pilot Face	10	Locating Pin	19	Idler & Bushing
2	Brkt Gasket - Pilot O.D.	11	Pipe Plugs	20	Head Gaskets
3	Bracket	12	Casing	21	Idler Pin
4	Capscrews for Bracket	13	Capscrew w/Orifice	22	Head & Idler Pin
5	Capscrews for Casing	14	Lockwasher	23	Pipe Plug
6	Pipe Plug	15	Key	24	Capscrews for Head
7	Casing Gasket	16	External Snap Ring	25	Gaskets for Relief Valve
8	Bracket Bushings	17	Rotor & Shaft	26	Relief Valve
9	Balance Plate	18	Idler Bushing	27	Capscrews for Relief Valve

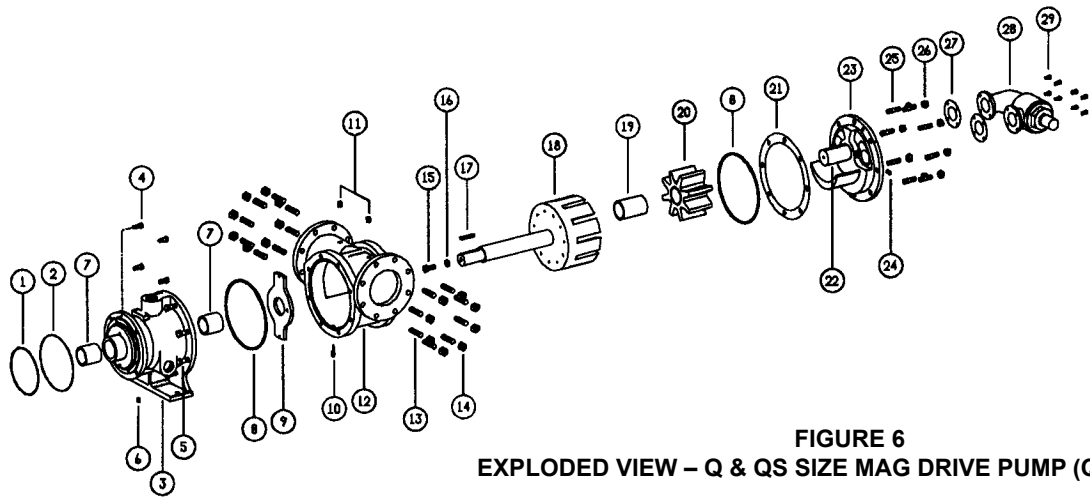

**FIGURE 6  
EXPLODED VIEW – Q & QS SIZE MAG DRIVE PUMP (QS SHOWN)**

ITEM	DESCRIPTION	ITEM	DESCRIPTION	ITEM	DESCRIPTION
1	Brkt Gasket - Pilot Face	11	Pipe Plugs	21	Head Gaskets
2	Brkt Gasket - Pilot O.D.	12	Casing	22	Idler Pin
3	Bracket	13	Studs for Flanges	23	Head & Idler Pin
4	Capscrews for Bracket	14	Nuts for Flanges	24	Pipe Plug
5	Capscrews for Casing	15	Capscrew w/Orifice	25	Stud for Head
6	Pipe Plug	16	Lockwasher	26	Nuts for Head
7	Bracket Bushings	17	Key	27	Gaskets for Relief Valve
8	Casing Gasket	18	Rotor & Shaft	28	Relief Valve
9	Balance Plate	19	Idler Bushing	29	Capscrews for Relief Valve
10	Locating Pin	20	Idler & Bushing		



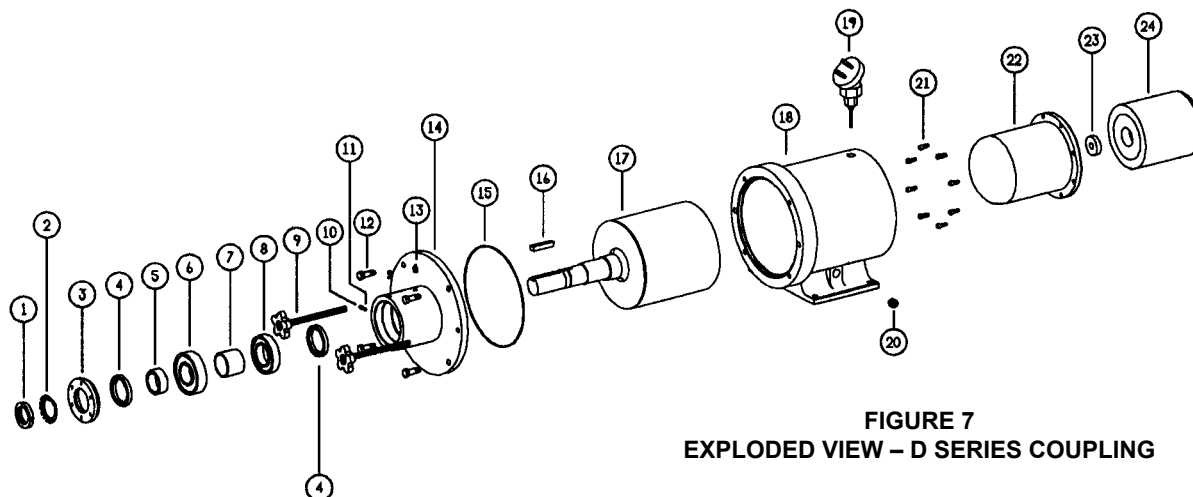

**FIGURE 7  
EXPLODED VIEW – D SERIES COUPLING**

ITEM	DESCRIPTION	ITEM	DESCRIPTION	ITEM	DESCRIPTION
1	Locknut	9	Jack Screws	17	Outer Magnet Assembly
2	Lockwasher	10	Set Screws	18	Bracket
3	Endcap	11	Insert	19	Temperature Monitor (Optional)
4	Lip Seals	12	Capscrews, Bearing Housing	20	Pipe Plug
5	Bearing Spacer, Outer	13	Grease Fitting	21	Capscrews for Canister
6	Tapered Roller Bearing, Outer	14	Bearing Housing	22	Canister
7	Bearing Spacer, Inner	15	Gasket, Bearing Housing	23	Washer
8	Tapered Roller Bearing, Inner	16	Key	24	Inner Magnet Assembly

## DISASSEMBLY: PUMP

### **DANGER !**

**Before opening any Viking pump liquid chamber (pumping chamber, reservoir, relief valve adjusting cap fitting etc.) Be sure:**

1. That any pressure in the chamber has been completely vented through suction or discharge lines or other appropriate openings or connections.
2. That the driving means (motor, turbine, engine, etc.) has been “locked out” or made non-operational so that it cannot be started while work is being done on pump.
3. That you know what liquid the pump has been handling and the precautions necessary to safely handle the liquid. Obtain a material safety data sheet (MSDS) for the liquid to be sure these precautions are understood.

**Failure to follow above listed precautionary measures may result in serious injury or death.**

1. See **Figure 5** or **Figure 6** on **page 5** for name of parts.
2. Mark the head, casing and bracket before disassembly to insure proper reassembly. The idler pin, which is offset in pump head, must be positioned toward and equal distance between port connections to allow for proper flow of liquid through pump.
3. Unless there appears to be something wrong with the relief valve (if present), leave assembled and attached to the pump head. If disassembly is required, refer to **PRESSURE RELIEF VALVES** on **page 12**. Remove the pump head capscrews (LQ & LS) or the nuts (Q & QS).
4. Carefully remove the head from the pump. Make sure the idler does not slide off the idler pin by tilting the pump head back while removing. Avoid damage to the head gasket set or O-ring since all gaskets are required to set end clearance and the O-ring enhances sealing.
5. Remove the idler and bushing assembly from idler pin. If the idler bushing needs replacing, see **INSTALLATION OF BUSHINGS** on **page 9**.

Disassembly and inspection of the pump in this manner is generally sufficient for routine evaluation of the pump's condition. If the idler pin and bushing are original parts and in good condition, usually the rest of the pump is also in good condition.

Before further disassembly of the pump can occur, the pump must be separated from the coupling. Refer to **DISASSEMBLY: MD-D SERIES COUPLING** on page 7 before proceeding with step 6.

6. After the inner magnet is removed from pump shaft, remove the external snap ring from pump shaft (LQ & LS only). The rotor and shaft may now be removed by tapping on the end of shaft with a soft face hammer or, if using a regular hammer, use a piece of hardwood between the shaft and hammer.
7. Because the balance plate is designed to be used in either rotation, mark the balance plate prior to removal. Remove balance plate by pulling out of casing.

Examine the casing for wear, particularly the area between the ports. All parts should be cleaned and checked for wear or damage before pump is assembled.

When making major repairs, such as replacing a rotor and shaft, it is advisable to also install a new head and idler pin, idler and bushing, bracket bushings, balance plate and head gaskets. See **INSTALLATION OF BUSHINGS** on page 9.

## PUMP ROTATION

Viking Mag Drive® pumps are directional. If it is necessary to rotate in the opposite direction, the pump must be disassembled through step 7. Rotate the balance plate 180° and reinstall into the casing. Second, the pipe plug (item 23 for LQ & LS, item 24 for Q & QS) must be on the suction side of the head. Remove the pipe plug and reinstall in the other similar hole in the head. Follow the procedure for pump assembly. Reverse the relief valve orientation so the adjusting cap points towards suction port.

## PORT ARRANGEMENT

Standard configuration (as viewed from the pump shaft) is right angle porting (LQ, LS & Q) – the suction port for clockwise rotation is at 9 o'clock. The top port (at 12:00) is the standard discharge port. If the desired configuration is different and the rotation is still clockwise, mark the suction port, remove the (8) bracket to casing cap screws and carefully rotate the casing on the bracket pilot then reinstall the cap screws. The QS features opposite ports and can not be rotated because the flanged ports will interfere with the pump bracket foot.

## DISASSEMBLY: MD-D SERIES COUPLING

### CAUTION !

**Magnet sets are extremely powerful. Serious injury may result if proper procedures are not followed.**

1. Install the two jackscrews (2-297-022-999) into the bearing housing. See **Figure 7 on page 6**, and **Figure 8**. Remove two 0.50" cap screws and thread a 0.50" NC x 8" threaded rod into these holes. Remove other two 0.50" cap screws.



FIGURE 8



FIGURE 9



FIGURE 10

2. Turn in the two jackscrews evenly, backing the bearing housing away from the bracket. See **Figure 8**. Install a strap from overhead to support the housing and outer magnet when the housing is approximately 1.50" away from the bracket. See **Figure 9**. Continue turning the jackscrews until the outer assembly comes out freely. See **Figure 10**.

3. Set the outer assembly with magnets down on a clean, flat surface (preferably not steel) to keep from rolling around. Remove temperature probe (if present).
4. To facilitate disassembly, it may be necessary to slide a block of wood under the pump casing or clamp pump foot as shown, since the pump alone will not balance on foot. See **Figure 11**. Remove the (4) 0.50" capscrews securing the pump to the coupling bracket. After parting the bracket slightly, it will have a tendency to be drawn to one side due to the inner magnet. Pull the coupling bracket completely away.

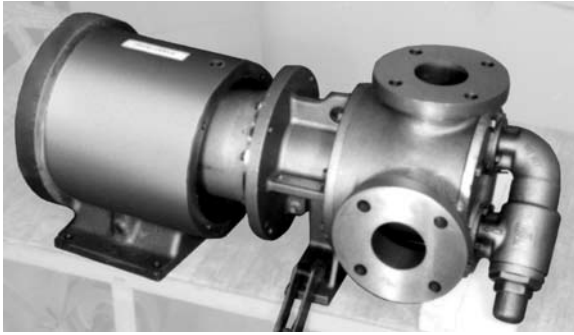

**FIGURE 11**

5. There will probably be some liquid left in the canister so take the necessary safety precautions. The canister drain is located behind the mounting flange and near the underside. Removing plug will drain most of the canister. Once the liquid has drained, replace the plugs.
6. Remove the (8) 0.375" Allen head capscrews holding the canister in place then slide the canister off. See **Figure 12**.



**FIGURE 12**

7. Insert a brass bar through a port between two rotor teeth and loosen the capscrew holding the inner magnet onto the shaft. See **Figure 13**. The 0.437" capscrew has right hand threads therefore turn it counterclockwise. **THE INNER MAGNET HAS A VERY STRONG MAGNETIC FIELD AND IS MOST DANGEROUS IN THE UN-ASSEMBLED CONDITION. THE MAGNET IS QUITE HEAVY AND WILL BE DRAWN TO ANY FERROUS OBJECT OR SURFACE CAUSING POTENTIAL PINCHING. BEWARE OF THE CAUTIONS LISTED ON (PAGE 3). USE EXTREME CARE SLIDING THE MAGNET OFF OF THE PUMP SHAFT. SET THE MAGNET DOWN ON EITHER END AWAY FROM ALL OTHER OBJECTS.** See **Figure 14**. Remove the key and the external snap ring (LQ & LS) and then finish disassembly of the pump.



**FIGURE 13**



**FIGURE 14**



# BEARING HOUSING

## DISASSEMBLY OF BEARING HOUSING

The bearing housing features two grease packed tapered roller bearings (TRB) along with a one-piece outer magnet assembly with shaft. The unit may be greased externally using the grease fitting. See **Figure 15** if further assembly is required and proceed as follows:

1. Cover the open end of the outer magnet with a piece of sheet metal. This will keep foreign material out of magnet area and protect the magnets. Set the assembly face down with the shaft pointing up and remove jackscrews.
2. Bend the lockwasher tab up and gently tap the locknut in a counterclockwise direction with a punch until loose. (If this does not work, place a key into shaft of outer magnet. Use 1.875" wrench to hold outer magnet and a spanner wrench to loosen lock nut. Remove the locknut and lockwasher. Then lift the bearing carrier off the shaft of the outer magnet assembly.
3. Back out the (2) setscrews holding the bearing cap then remove the bearing cap with a spanner wrench. The inner and outer spacers, outer TRB and inner TRB cone should all slide out of the bearing housing.
4. One lip seal is pressed into the bearing cap and the other is pressed into the bearing housing. Do not remove unless replacing.
5. If inner TRB is worn or damaged, remove cup of inner TRB.

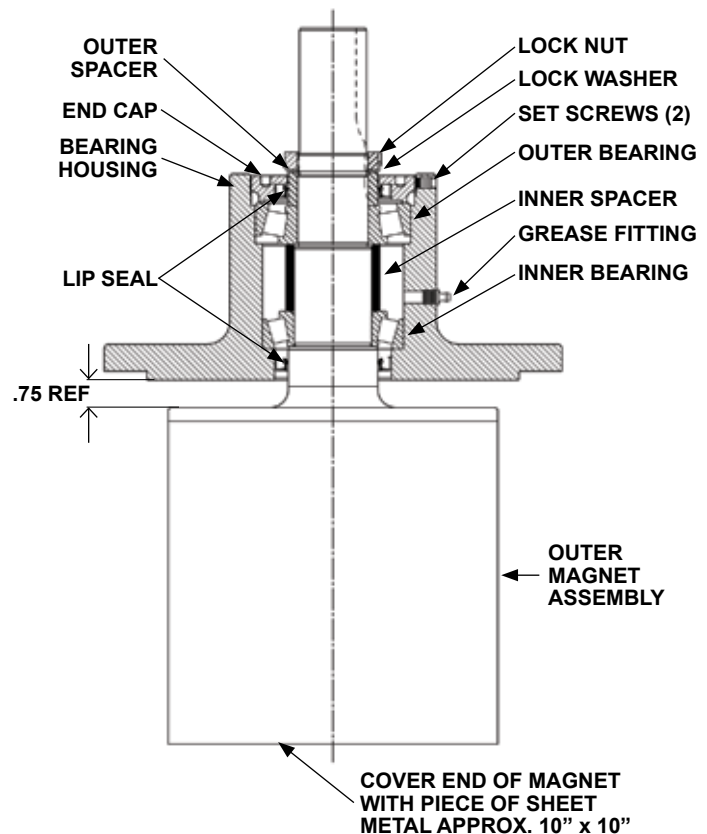

FIGURE 15

## ASSEMBLY OF BEARING HOUSING

Depending on the condition of the bearings either replace or recondition existing bearings by cleaning and packing with a heavy duty grease. Replace the lip seals if necessary.

1. Place the bearing carrier down with the cast surface up. Install the inner lip seal (if removed). Then install the cup (if removed) of the inner TRB and the cone into the bearing housing bore. Insert the inner bearing spacer (longer one of the two) and the outer TRB into the bore. Place outer spacer on top of the cone of the outer TRB.
  2. The outer end cap houses the second lip seal. If the seal is in good condition, slide the endcap over the outer spacer then thread into bearing housing. Center the inner spacer so the shaft will slide through the two bearings. Thread in the end cap until it makes contact with the outer TRB. Tighten the endcap by hand until tight and secure in position with the (2) setscrews.
  3. Insert the outer magnet shaft through the bearings and the spacers. When the shaft is in the proper position there should be approximately 0.75" between the magnet and the housing. See **Figure 15**.
  4. Place the lock washer onto the shaft then thread the locknut onto the shaft. Tighten locknut to 50 Ft-Lbs then bend over a lockwasher tab.
  5. Tighten the endcap to 75 Ft-Lbs and rotate bearing housing 2-3 turns. Back off the end cap and then retighten to 75 Ft-Lbs. Tighten the two .31" setscrews onto the endcap.
- Use the grease fitting to fill the bearing chamber with additional grease.

## INSTALLATION OF BUSHINGS

### CARBON GRAPHITE:

When installing carbon graphite bushings, extreme care must be taken to prevent breaking. Carbon graphite is a brittle material and easily cracked. If cracked, the bushing will quickly disintegrate. Using a lubricant on the bushing and mating part will help in installation. The additional precautions listed below must be followed for installation:

1. An arbor press must be used for installation.
2. Be certain bushing is started straight.
3. Do not stop pressing operation until bushing is in proper position, starting and stopping will result in cracking bushing.
4. Check bushing for cracks after installation.

### SILICON CARBIDE:

When installing silicon carbide bushings into a metal part the mating part must be heated to 600°F (preferably in an oven). Bushing must be quickly put into the proper position before the mating part cools down and the bushing heats up. **FAILURE TO FOLLOW THIS PROCEDURE WILL RESULT IN CRACKED BUSHINGS.**

# PUMP ASSEMBLY

Use a lubricant compatible with the fluid being handled when reassembling the pump.

Inspect all parts, replacing any worn parts. Polish out any nicks or burrs and clean all parts thoroughly. Make sure drilled holes in rotor, shaft, orifice, balance plate and bracket are clear. Plugged areas will cause heat buildup and destroy the magnets. Also check the drilled passageways in the head and idler pin to be sure they are clear.

1. If the casing was removed from the bracket, place the O-ring into the groove on back mounting face of casing (side closest to the hole for the locating pin), and carefully slide the casing onto the pilot of the bracket and install capscrews. Install the locating pin into the casing.
2. Place the balance plate into the casing bore with grooved side out. Orient the groove toward the discharge port. Push to the bottom of the casing. Line up the notch in plate with the pin projecting through the casing bore.
3. Insert the shaft gently into the inner bushing bore and push through until rotor is up against the balance plate.
4. If the old head gaskets are not reusable, refer to Gasket Table **Figure 18**. Otherwise, place all head gaskets on the head. Proper placement of gaskets. Improper placement will adversely affect the operation of the pump. The Gasket Table shows the recommended end clearance and itemizes the content of gaskets in a set. The O-ring is the primary seal and should be installed onto the head pilot after the proper gaskets have been put in place.
5. Coat the idler pin with suitable lubricant and place the idler on the idler pin in head.
6. The head can now be assembled on the pump. Tilt the top of the head away from the pump slightly until the crescent enters the inside diameter of the rotor and rotate the idler until its teeth mesh with the rotor teeth. Line up mark on head and casing, which were previously marked to insure proper reassembly. Be sure idler pin, which is offset in pump head, is positioned toward and equal distance between port connections to allow for proper flow of liquid through pump. Tighten the head capscrews (or nuts onto studs in the Q size). Check the end clearance using a feeler gage as illustrated. See **Figure 20** on page 11. If end clearance is not correct, refer to section on **ADJUSTING HEAD GASKET END CLEARANCE** on page 11.
7. Install relief valve if provided and removed.
8. Install the snap ring onto the shaft (not required on Q size). Apply a lubricant to the canister O-ring and place into the face groove in the bracket.

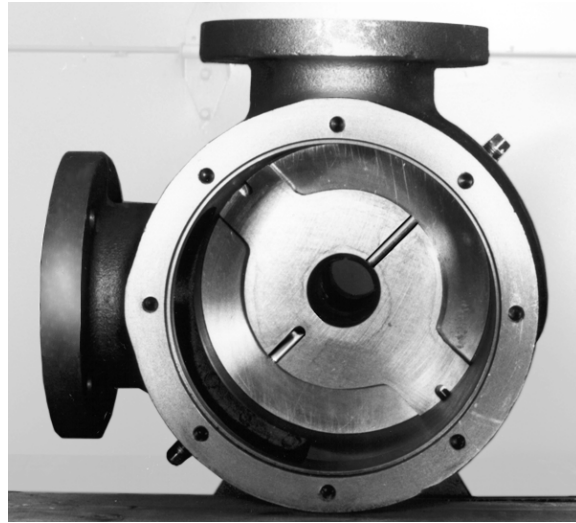

FIGURE 16



FIGURE 17

## GASKET TABLE

PUMP MODEL	NORMAL ① END CLEARANCE	ONE SET OF GASKETS CONSISTS OF THE FOLLOWING
LQ & LS-825	.008	(1) .015
		(2) .007
		(2) .005
Q & QS-825	.010	(1) .015
		(2) .007
		(3) .005

① End clearances are adequate for viscosities up to 750 SSU (SAE 20-lube oil at room temperature). Higher viscosity liquids require additional end clearances.

As a general guideline, for viscosities between 750 and 7500 SSU (heavier lube oils) add an additional 50% of the end clearance listed, for viscosities between 7500 and 25,000 SSU (e.g., resins) double the amount indicated.

For specific recommendations for end clearances for viscosity or for operating temperatures above 225°F, check with your Viking representative or consult the factory.

FIGURE 18

## ADJUSTING HEAD GASKET END CLEARANCE

Use either of the following procedures to properly adjust the end clearance, when replacing gaskets.

### PROCEDURE A:

With the casing secured to the bracket and balance plate in position, slide the rotor and shaft into the casing. Insert the feeler gage of the proper thickness into the port and between two rotor teeth. Install one .015" and .007" gasket onto the head. With the idler on idler pin, place head into the pump casing. With capscrews tight, the feeler gage should fit snugly; otherwise gaskets should be added or removed until the proper clearance is attained. See **Figure 19**.

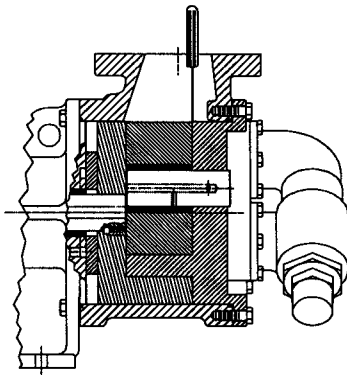

FIGURE 19

### PROCEDURE B:

If the pump is in the pipeline and not accessible through ports, remove the head and remove gaskets. Put the head back on and measure the gap as shown. See **Figure 20**. After determining the gap between head and casing, select a combination of gaskets with approximately 25% more total thickness than the feeler gage plus required end clearance. See **Figure 18 on page 10**. Note: gaskets will compress when head is tightened down. Remove head, install all gaskets and the O-ring, and then install head. Tighten the head capscrews and then check the pump by making sure the pump turns over freely by hand.

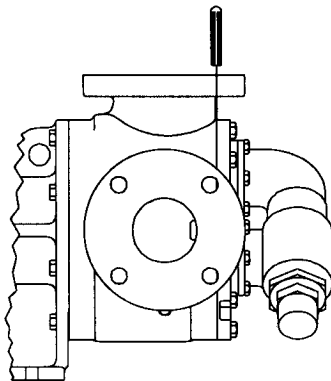

FIGURE 20

## ASSEMBLY: D SERIES COUPLING

1. Remove any foreign material attached to the magnets. Place key in pump shaft and slide inner magnet on shaft until it comes to rest against shoulder on shaft. Insert washer, lockwasher and capscrew into end of magnet and tighten. May require inserting brass bar into port to block rotor from turning. Install O-ring into face of pump bracket then slide canister over inner magnet and secure with the capscrews.

### DANGER !

**Follow these directions exactly to avoid injury to self or damage to pumping unit, be extremely careful to keep inner & outer magnets at least (1) foot apart until step 3. Do not allow magnets to engage in any other fashion. Be aware of health hazards listed on (page 2).**

2. Place a spacer under pump so the foot sits flat and clamp foot to the table. Install one of the secondary O-Ring seals onto the pump pilot then slide the coupling bracket up to pump and bolt together.
3. Install two threaded rods into the bracket on the other end. Insert the (2) jackscrews into their holes of the bearing housing and thread in completely. Install other secondary O-ring onto the bearing housing pilot. Support the bearing housing assembly from over head then slide onto the (2) threaded rods. Balance the assembly and glide outer magnet onto canister until jackscrews come to rest in the two counter bored holes on the bracket. **BE CAREFUL TO CENTER THE OUTER MAGNET WHILE STARTING TO ENGAGE CANISTER.** Depending on lengths of magnets the unit may be drawn in as the jackscrews are removed or may require pushing in. Evenly back off the jack screws until the housing is approximately 1" from the bracket then remove the over head support and finish backing off the jack screws. The housing may require a slight lift to get into the pilot of the bracket. Secure with (2) capscrews then remove the rods and install final (2) capscrews.

### DANGER !

**Before starting pump, be sure all drive equipment guards are in place.**

**Failure to properly mount guards may result in serious injury or death.**

## TROUBLESHOOTING

Some of the following may help pinpoint the problem:

### Pump does not pump:

- Pump has lost its prime from air leak or low level in tank.
- Suction lift is too high
- Pump is rotating in the wrong direction
- Suction and/or discharge valves not open.
- The strainer may be clogged.
- The bypass valve is open, the pressure relief valve is set too low or the pressure relief valve poppet stuck open.
- Improper end clearance
- The pump is worn out.
- Are there any changes in liquid, system or operation that would influence pump or coupling performance, e.g. new liquid, additional lines or process changes?
- Temperature changes either in the liquid or the environment.
- The magnetic coupling is decoupling. Changes in application (temperature, pressure, viscosity, etc.) may require torque beyond coupling capabilities.

### Pump starts, then loses its prime:

- The supply tank is empty
- Liquid vaporizing in the suction line
- An air leak or air pocket in the suction line.

### Pump is noisy:

- Pump is being starved (heavy liquid cannot get to pump fast enough). Increase suction pipe size, reduce its length or slow down the pump.
- Pump is cavitating (liquid vaporizing in suction line). Increase suction pipe size or reduce its length.
- Check alignment.
- The magnetic coupling has decoupled. Shut off and restart.

### Pump is not delivering up to capacity:

- The pump is starving or cavitating – increase suction pipe size or reduce length or reduce pump speed.
- The strainer is partially clogged.
- An air leak somewhere in suction line.
- The pump may be running too slow. Is motor the correct speed and wired up correctly?
- The pressure relief valve is set too low, stuck open or has a damaged poppet or seat.
- The bypass line around the pump is partially open.
- The pump is worn out or has too many gaskets.

### Pump takes too much power (stalls motor):

- The liquid is more viscous than the unit is sized to handle.
- The system pressure relief valve is set too high.
- The coupling is misaligned.
- The bushings have frozen up or the liquid has set up in the coupling.

## PRESSURE RELIEF VALVES

### PRESSURE ADJUSTMENT

If a new spring is installed or if pressure setting of pressure relief valve is to be changed from that which the factory has set, the following instructions must be carefully followed.

1. Carefully remove the valve cap, which covers adjusting screw. Loosen locknut, which locks adjusting screw so pressure setting will not change during operation of pump.
2. Install a pressure gauge in discharge line for actual operating adjustment.
3. Turn adjusting screw in to increase pressure and out to decrease pressure.
4. With discharge line closed at a point beyond pressure gauge, gauge will show maximum pressure valve will allow while pump is in operation.



FIGURE 21

### LIST OF PARTS

1.	Valve Cap	6.	Valve Body
2.	Adjusting Screw	7.	Valve Spring
3.	Lock Nut	8.	Poppet
4.	Spring Guide	9.	Cap Gasket
5.	Bonnet	10.	Bonnet Gasket

**IMPORTANT:** In ordering parts for pressure relief valve, always give model number and serial number of pump as it appears on nameplate and name of part wanted. When ordering springs, be sure to give pressure setting desired.





SECTION	TSM 845.1
PAGE	13 OF 13
ISSUE	C

## DISASSEMBLY: RELIEF VALVE

### DANGER !

Before opening any Viking pump liquid chamber (pumping chamber, reservoir, relief valve adjusting cap fitting, etc.) be sure:

1. That any pressure in the chamber has been completely vented through the suction or discharge lines or other appropriate openings or connections.
2. That the driving means (motor, turbine, engine, etc.) has been "locked out" or made non-operational so that it cannot be started while work is being done on pump.
3. That you know what liquid the pump has been handling and the precautions necessary to safely handle the liquid. Obtain a material safety data sheet (MSDS) for the liquid to be sure these precautions are understood.

Failure to follow above listed precautionary measures may result in serious injury or death.

Mark valve and head before disassembly to insure proper reassembly.

1. Remove valve cap.
2. Measure and record length of extension of adjusting screw. Refer to "A" on **Figure 21 on page 12**.
3. Loosen locknut and back out adjusting screw until spring pressure is released.
4. Remove bonnet, spring guide, spring and poppet from valve body. Clean and inspect all parts for wear or damage and replace as necessary.

## ASSEMBLY: RELIEF VALVE

Reverse procedures outlined under Disassembly. If valve is removed for repairs, be sure to replace in original position. Relief valve adjusting screw cap must always point toward suction side of pump. If pump rotation is reversed, remove relief valve and turn end for end. See **Figure 3 on page 3**. Also refer to **PUMP ROTATION on page 7**.



## WARRANTY

Viking warrants all products manufactured by it to be free from defects in workmanship or material for a period of one (1) year from date of startup, provided that in no event shall this warranty extend more than eighteen (18) months from the date of shipment from Viking. If, during said warranty period, any products sold by Viking prove to be defective in workmanship or material under normal use and service, and if such products are returned to Viking's factory at Cedar Falls, Iowa, transportation charges prepaid, and if the products are found by Viking to be defective in workmanship or material, they will be replaced or repaired free of charge, FOB. Cedar Falls, Iowa.

Viking assumes no liability for consequential damages of any kind and the purchaser by acceptance of delivery assumes all liability for the consequences of the use or misuse of Viking products by the purchaser, his employees or others. Viking will assume no field expense for service or parts unless authorized by it in advance.

Equipment and accessories purchased by Viking from outside sources which are incorporated into any Viking product are warranted only to the extent of and by the original manufacturer's warranty or guarantee, if any.

THIS IS VIKING'S SOLE WARRANTY AND IS IN LIEU OF ALL OTHER WARRANTIES, EXPRESSED OR IMPLIED, WHICH ARE HEREBY EXCLUDED, INCLUDING IN PARTICULAR ALL WARRANTIES OF MERCHANTABILITY OR FITNESS FOR A PARTICULAR PURPOSE. No officer or employee of IDEX Corporation or Viking Pump, Inc. is authorized to alter this warranty.

### DANGER !

Before starting pump, be sure all drive equipment guards are in place.

Failure to properly mount guards may result in serious injury or death.