



Users Manual

Defender 3 – 480V or 480Y/277V in
Three Phase
Online Emergency Lighting Inverter

Technical Manual #018-0105-01 Revision A

Phone: 1.877.DSPM.POWER
1.877.377.6769

Fax: 909.930.3335

Website: www.DSPManufacturing.com

E-Mail: techsupport@dspmanufacturing.com

TABLE OF CONTENTS

Introduction.....	3
Important Safety Instructions.....	4
General.....	6
Unit Information.....	6
Front Panel Description.....	7
History Log Key.....	8
Bypass Switch Description.....	9
System Component Layout.....	10
Installation.....	12
Inspection.....	12
Placement.....	12
Connections.....	13
Interface.....	13
Internal Battery Pack.....	14
Connection to Utility.....	14
Charging of the Batteries.....	14
Connection of the Loads.....	14
System Ratings.....	15
Operation.....	16
Start Up.....	16
Turning System Off.....	16
Manual Bypass.....	17
Battery Run Audible Alarm.....	17
Low Battery (Rapid Alarm).....	17
Direct Communications.....	17
Maintenance.....	18
Technical Support.....	18
Battery Connections.....	18
Environmental Control Module.....	19
Notes.....	23

Introduction

Save these instructions

Please read and save this manual!

Thank you for selecting this Emergency Lighting Inverter System. It provides you with perfect protection for connected loads and equipment. The manual is a guide to install and use the Emergency Lighting Inverter System. It includes important safety instructions for operation and correct installation of the Emergency Lighting Inverter System. If you should have any problems with the Emergency Lighting Inverter System, please refer to this manual or call technical support at 1.877.377.6769

Please save or recycle the packaging materials!

The Emergency Lighting Inverter System shipping materials are designed with great care to provide protection within delivery. These materials are invaluable if you have to return the Emergency Lighting Inverter System for service. Damage happening during transit not covered under the warranty; please call the freight carrier immediately or DSPM customer service to report any damage.

Intelligent Microprocessor Control

The product is an advanced Emergency Lighting Inverter System based on microprocessor control.

The Emergency Lighting Inverter System is an intelligent protector and provides pure, reliable AC power to the emergency loads – protecting them from utility power blackouts, swells, sags, surges and interference. Our lighting inverter supports all types of lamps.

Under normal power conditions, the design enables the system to adjust and filter power fluctuations continuously and automatically. In the event of power failure, it can immediately provide back-up power from the batteries without any interruption.

When the utility power is connected, the charger will automatically recharge the batteries.

Advanced Battery Management

The visual and audible indications of the Emergency Lighting Inverter System present the battery's status, including capacity and battery conditions. The self-test function lets the Emergency Lighting Inverter System detect a weak battery. The Emergency Lighting Inverter System performs a self-test at power up. Self-test function can be conducted manually with the ON/TEST switch at any time.

Important Safety Instructions

Transportation and/or Moving Unit

Please transport the Inverter with care to ensure the unit is protected against shock and impact.

Set-up

Ensure the unit is completely dry before being installed. Moving the unit directly from a cold to warm environment may cause condensation to form on electronic/electrical parts. Please allow an acclimatization time adequate for all condensation/water to evaporate.

Do not install the Inverter near water or in damp environments.

Do not install the Inverter where it could be exposed to direct sunlight or near heat.

Do not block off ventilation openings in the Inverter cabinet.

◆ **WARNING:** Intended for installation in a controlled environment.

Installation

Connect conduit in such a way that no one can step on or trip over the conduit.

Batteries

◆ **CAUTION:** Risk of electrical shock – Hazardous live parts inside unit are energized from the internal battery supply even when the input AC power is disconnected.

◆ **CAUTION:** Risk of electrical shock, non-isolated battery circuit. Hazardous voltage may exist between battery terminals and ground.

◆ **CAUTION:** Do Not dispose of batteries in a fire, the battery may explode.

◆ **CAUTION:** Do Not open or break apart the battery, released electrolyte is harmful to the skin and eyes.

◆ **CAUTION:** A battery can present a risk of electrical shock and high short circuit current. The following precautions should be observed when working on batteries:

- Remove watches, rings and/or other metal objects.
- Use tools with insulated handles.
- Servicing of batteries should be performed or supervised by personnel knowledgeable of batteries and the required precautions.

DO NOT Dismantle the Emergency Lighting Inverter System.

Operation

- ◆ **CAUTION:** The Inverter System features its own internal power source (batteries). The UPS/Inverter System output circuits may be electrically live, even if the Inverter System is not connected to the building wiring power source (utility).
- ◆ **CAUTION:** Ensure that no fluids or other foreign objects can enter the Inverter System.
- ◆ **CAUTION:** The Inverter System operates with hazardous voltages. Only qualified maintenance personnel may carry out service.

Service

- ◆ **CAUTION:** Risk of electrical shock, do not remove cover. No user serviceable parts inside. Refer servicing to qualified service personnel.
- ◆ **CAUTION:** To reduce the risk of electrical shock; disconnect the Emergency Lighting Inverter System from the main supply before installing an interface signal cable. Reconnect the power only after signaling interconnections have been made.
- ◆ **CAUTION:** The Inverter System operates with hazardous voltages. Only qualified maintenance personnel may carry out repairs.
- ◆ **CAUTION:** Risk of electrical shock, non-isolated battery circuit. Hazardous voltage may exist between battery terminals and ground.

Only TRAINED personnel familiar with batteries and with the required precautionary measures may replace batteries and supervise operations. Unauthorized persons must be kept well away from the batteries.

- ◆ **CAUTION:** A battery can present a risk of electrical shock and high short circuit current. The following precaution should be observed when working on batteries:

- Remove watches, rings and/or other metal objects.
- Use tools with insulated handles.
- Servicing of batteries should be performed or supervised by personnel knowledgeable of batteries and the required precautions.
- Keep unauthorized personnel away from batteries.

When replacing or charging batteries, install the same number and same type of batteries.

Do not attempt to dispose of the batteries by burning them. This could cause batteries to explode.

- ◆ **CAUTION:** Do Not open or break apart the battery, released electrolyte is harmful to the skin and eyes.

General

Unit Information

The Defender 3 is an Emergency Lighting Inverter System incorporating double-conversion technology. It provides perfect protection specifically for Egress Lighting for facilities.

The inverter is a double-conversion three-phase unit that eliminates all sources of power disturbances. A rectifier converts the alternating current from the building source to Direct Current (DC). This DC charges the batteries and powers the inverter. With the basic DC voltage, the inverter generates a sinusoidal alternating current (AC) voltage, which continuously supplies the load.

The load is powered by the inverter, which receives its power from the building source. In the event of the loss of the building source power the inverter will then derive it's power from the batteries.

All units come standard with a 90-minute backup time.

Front Panel Description

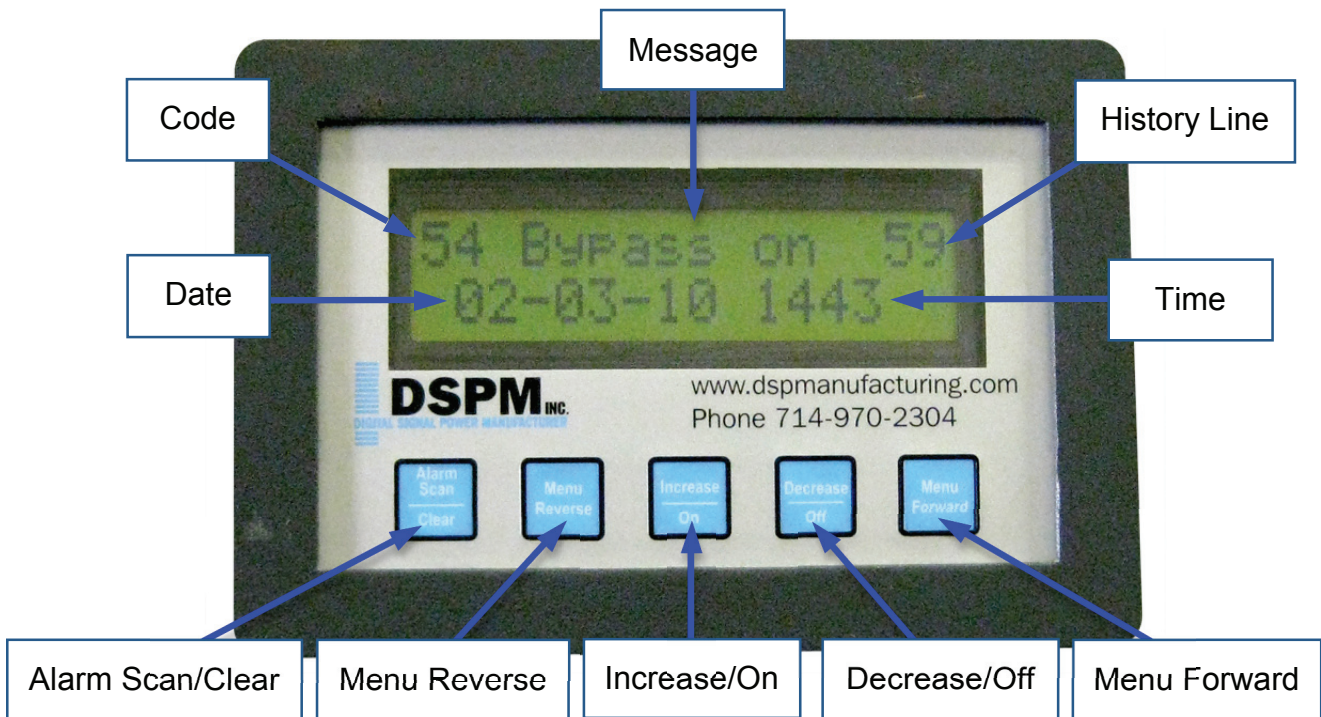

Code: Indicated which alarm has been triggered. Use the History Log Key to help find the description of the alarm.

Message: Indicates the message for the alarm that was triggered.

History Line: Indicates the line that an event has been recorded on.

Date: Indicates the date that the alarm was triggered.

Time: Indicates what time the alarm was triggered; the time is shown in military time.

Alarm Scan / Clear: By holding down this button you can scroll the history log. By pressing this button you can clear.

Menu Reverse: To scroll menu left.

Increase / On: To change setting up.

Decrease / Off: To change setting down.

Menu Forward: To scroll menu right.

History Log Key

The *History Log* is used to record certain events that reflect the status and operating mode of the unit.

There are 64 lines (00 through 63).

It is read by holding down the *Alarm Scan* button. Each time the button is pressed, the log is read sequentially with the recent event being displayed first. After 00 is displayed, the system will cycle around to 63. After 64 events are logged, the system will start recording again at 00.

Code	Message	Description
00	00	Blank - Used for clearing Alarm History
01	alarm clr	Alarm History has been cleared
02	Phase SEQ	Input phase sequence has caused a fault and must be changed
04	Input OV	Input voltage has gone over fault limit
05	Input UV	Input voltage has gone below fault limit
07	Input CONT	System has failed to detect closure of the Input Contactor
08	Output Hi V	Output voltage has gone over fault limit
09	Output Lo V	Output voltage has gone below fault limit
10	Output O Frq	Output frequency has gone over fault limit
11	Output U Frq	Output frequency has gone below fault limit
12	Phase FLT	Input phase sequence fault has not been corrected and system has timed out
13	Invrtr FLT	A hardware fault has been detected by the inverter control board (IGBT PCBA); caused by IGBT failure, unexpected power on reset, or DC Bus over voltage
14	DC Bus OV	DC Bus has gone over fault limit
15	DC Bus UV	DC Bus has gone below fault limit
16	Input O Frq	Input frequency has gone over fault limit
17	Input U Frq	Input frequency has gone below fault limit
18	RECT off	Rectifier has shut off unexpectedly
20	Invert O Frq	Inverter frequency has gone over fault limit
21	Invert U Frq	Inverter frequency has gone below fault limit
22	ISBS open	Inverter Static Bypass Switch has not engaged and system has timed out
23	USBS fault	Utility Static Bypass Switch has failed test
24	USBS short	Utility Static Bypass Switch failure, output voltage still detected after off command was issued
26	Output OVL	Output Current has gone over fault limit
28	Estop OPEN	Emergency Stop option enabled during system to switch to bypass
35	UPS abort	System faults have caused system to switch to bypass

Code	Message	Description
36	Normal run	Automated system test concluded
37	BATT test	Automated system test initiated (15 minutes rectifier shutoff and battery run)
38	Inv start	Inverter has been started and matched with utility voltage
40	NMI trap	NMI button on processor board has been pressed, date and time marker
41	STKUF trap	Software Stack underflow detected
42	STKOF trap	Software Stack overflow detected
43	WDTMR trap	Software has detected a Watchdog timer overflow
45	ISBS xfer	Static Bypass Switch has transformed load to Inverter
46	Inv Stop	Inverter has unexpected shut off
47	Pwr on RST	CPU initialization complete
49	ESTOP trap	Emergency Stop option has caused an emergency transfer to utility
50	RunState0	Power has been applied to system
51	RunState1	Initial system checks complete, awaiting DC breaker closure
52	RunState2	Startup complete, system ready
53	RunState3	Utility power failure, system is on a battery run
54	Bypass on	System is in bypass
56	Battery Low	Battery Voltage is low, causing a system shutdown
57	Key Code OK	Key Code Accepted
58	Air Flow DN	Air Flow fault detected, DC Bus set to minimum value
59		Master reset code excepted
60		Auto Equalizer
61		Manual Equalize On
62		Manual Equalize Off

Bypass Switch Description

This switch is located on the top shelf, on the left hand side of the system. (See system component diagram for exact location). The bypass switch is used in case of a failure of the lighting inverter. If the lighting inverter fails place the bypass switch in the “MAN” position. In this position the inverter section is bypassed allowing the load to be powered by the utility until the inverter can be repaired. Contact factory for service.

Normal Operation



Bypass Option



NOTE: Operation of the bypass switch will cause the static switch to utility bypass and turn off the inverter (if it was running.)

◆ **WARNING:** The manual bypass switch should only be operated by authorized personnel.

System Component Layout

The following layout will help you find the parts and components in your Emergency Lighting Inverter. If you need technical assistance, please contact DSPM. Do not attempt to service. Factory-trained personnel should perform maintenance only.

- 1 - Input Breaker
- 2 - Input Terminal Blocks
- 3 - Fuses
- 4 - Bypass Switch
- 5 - Reference Transformer
- 6 - Contactor
- 7 - Rectifier Breaker
- 8 - Reference Transformer
- 9 - Rectifier Bridge
- 10 - Battery Breaker
- 11 - Drive Transformer
- 12 - Fan Transformer
- 13 - Main Output Breaker
- 14 - Fuses
- 15 - Reference Transformer
- 16 - Output Terminal Blocks
- 17 - Manufacturer's Label
- 18 - Input Filters
- 19 - Output Filters
- 20 - Transformer
- 21 - Inductors
- 22 - DC Reactor
- 23 - DC Caps
- 24 - Inverter Filters

(Batteries are to be placed on top shelf)

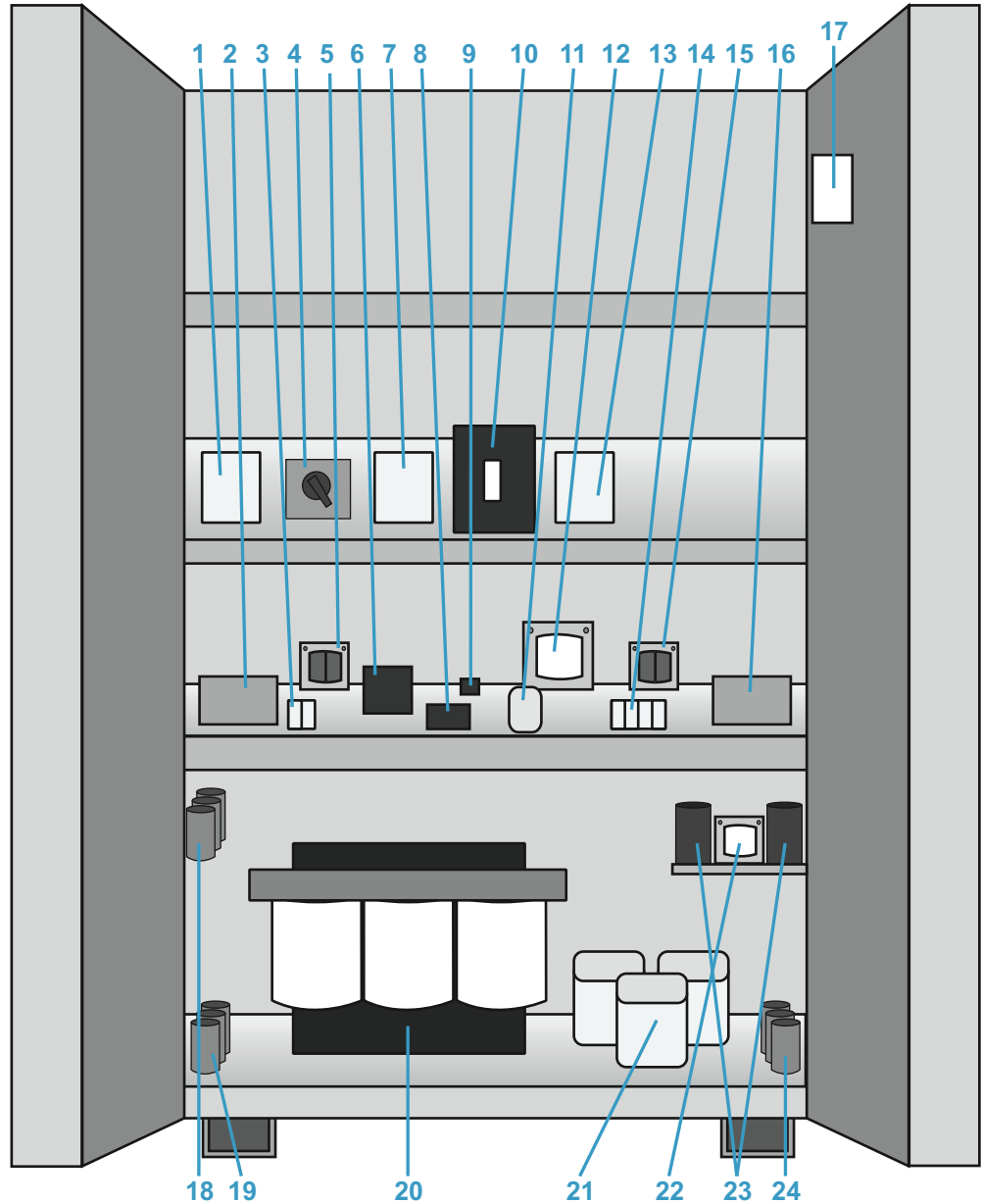

Inside door layout:

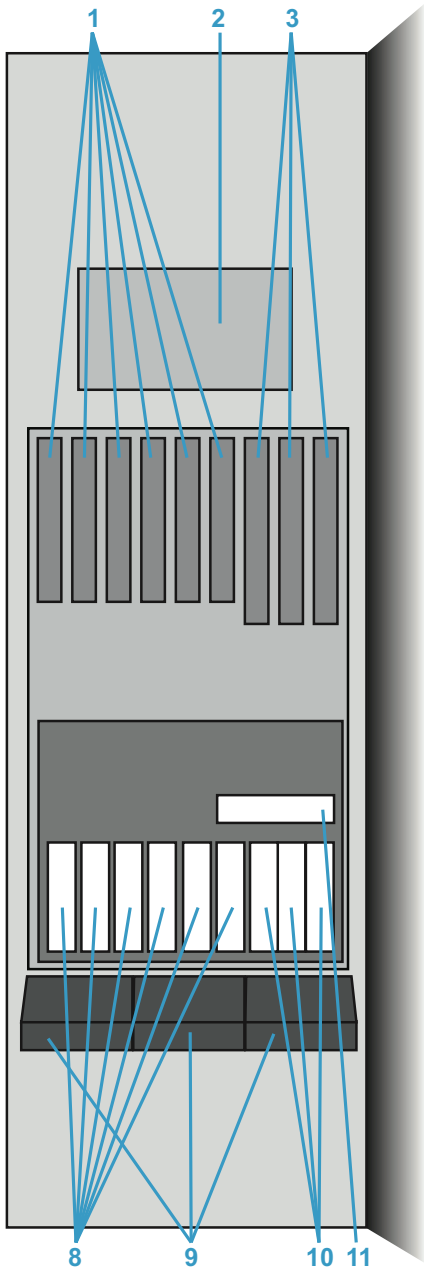

- 1 - SBS Driver Boards
- 2 - SBS PCBA
- 3 - Rectifier Driver Boards
- 4 - Manufacturer's Label
- 5 - Monitor PCBA
- 6 - Display
- 7 - Computer Interface*
- 8 - SBS SCR's
- 9 - Cooling Fans
- 10 - Rectifier SCR's
- 11 - Diode
- 12 - Inverter Assembly

*Please see the "Interface" section of this manual for more detailed information

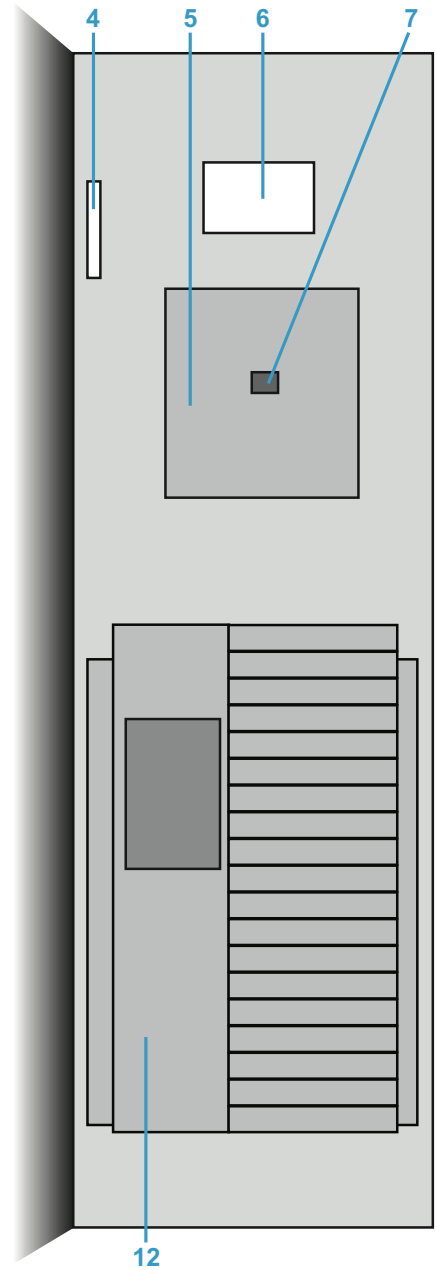

Installation

Inspection

Inspect the Emergency Lighting Inverter System upon receipt. If there was any damage during transportation; Do Not turn on the unit and notify the carrier and DSPM immediately.

The packaging is recyclable; keep it for reuse or please disposed of it properly.

Placement

Install the Emergency Lighting Inverter System in a protected area with adequate airflow and free from excessive dust. Do not operate the Emergency Lighting Inverter System where the temperature and humidity is out of the specified limits.

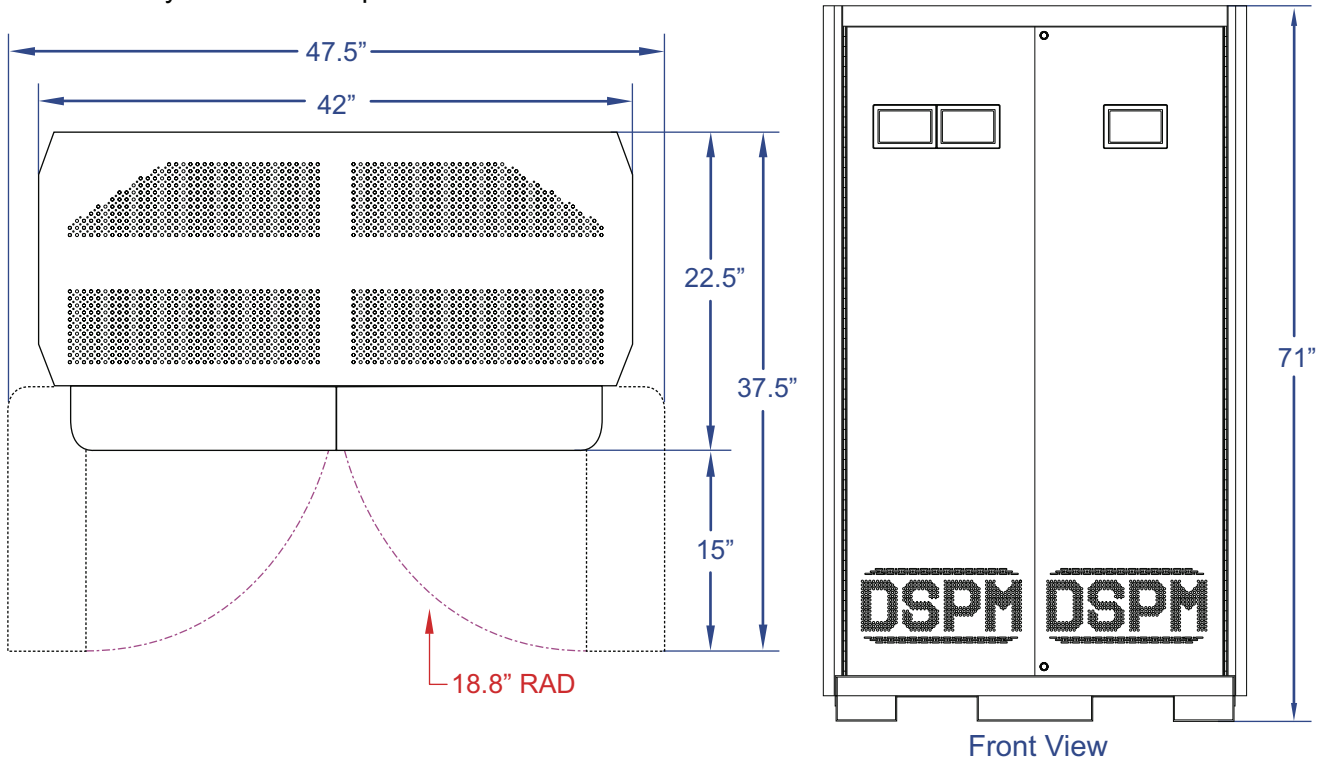

Per code requirements please leave 3" on each side of the cabinet including the back, and a 3 foot clearance in front.

Storage of the system should be in a cool and dry area with the unit being upright and covered. The unit cannot be stored for more then 3 months without charging the batteries.
The warranty can be affected.

Operating Temperature: 0° to 40°C (32° to 104°F) Storage Temperature: -20° to 60°C (-4° to 140°F)



Defender 3: 480V or 480Y/277V in • Online Emergency Lighting Inverter
Technical Manual #018-0105-01 Rev A

Connections

◆ **WARNING:** Condensation of water may occur if the system is unpacked in a very low temperature environment. In this case it is necessary to wait until the system is fully dried inside out before proceeding with the connection of any power, otherwise there are hazards of electrical shock.

Installation and wiring must be performed in accordance with the local electric code and the instructions of professional personnel.

Interface (optional)

Software interface kits can be used with this Emergency Lighting Inverter System. Contact the factory for kits supplied or approved by DSPM. If used, connect the interface cable to the 9-pin computer interface port (RS-232 Standard Interface Port) on the main control PCB in top of Emergency Lighting Inverter System.

The RS-232 interface uses 9-pin female D-sub connector. This information consists of data about utility, load and the Emergency Lighting Inverter System. The interface port pins and their functions are identified in the following table.

NOTE: Interface connection is optional. The Emergency Lighting Inverter System works properly without an optional interface connection.

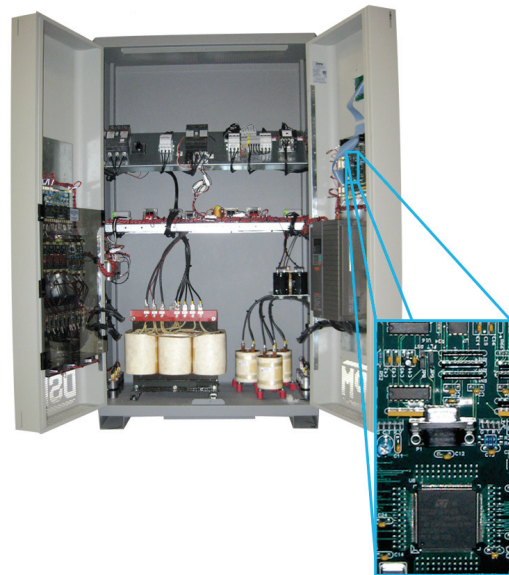
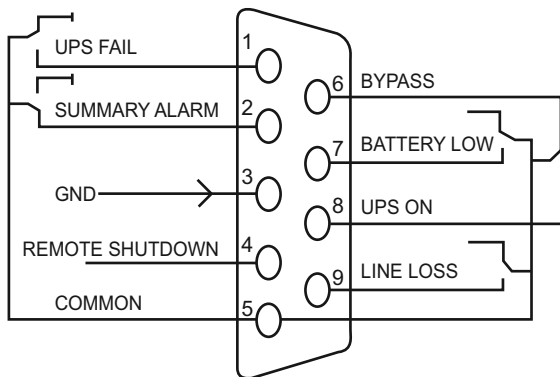

◆ **CAUTION:** Use only factory supplied or authorized Emergency Lighting Inverter System monitoring cable!

Internal Battery Pack

Before connecting, ensure that the batteries are connected according to the battery diagram (negative of first battery to positive of the second battery, negative of the second battery to positive of third battery, etc.). After connecting all the batteries connect the positive lead (Red) from the battery circuit breaker(s) (CB2) to the positive terminal. Connect the black to the negative side of the circuit breaker.

◆ **WARNING:** Make sure the proper polarity is observed. DC bus should be between 96 and 108 Vdc as tested at the top of the battery circuit breaker (CB2).

Connection to Utility

Ensure that the utility power to be connected is as listed on the system label, and the hots, neutral and grounds are correctly identified and wired to the input terminal blocks as designated.

Charging of the Batteries

The Emergency Lighting Inverter System charges it's battery whenever it is connected to utility power and the input circuit breakers (CB1) is turned on. For the best results, charge the battery for 24 hours in the initial use.

Connection of the Loads

Ensure that the loads to be connected are as listed on the system label, and the hots, neutral and grounds are correctly identified and are wired to the output terminal block as designated.

◆ **CAUTION:** Do not bond the output neutral to chassis ground! The system has been bonded as required by the manufacturer and NEC.

Loads not powered by the system cannot use the neutral of the Emergency Lighting Inverter System. Any load powered by the Emergency Lighting Inverter System line and neutral outputs only.

System Current Ratings

All circuit breakers provided by the end user that are connected to the inputs and outputs need to have a trip curve which is at least 10 times the rated current for .3 seconds. This is to prevent the breakers from tripping during startup of the unit or the loads, attached to the unit. Some manufacturers refer to these breakers as “High Inrush” breakers.

KW	Input Voltage	Utility Feed Amps	Output Voltage	Max Output Amps
3.0	480Y/277	6.3/111	208Y/120	8.3/14.5
			480Y/277	3.6/6.3
	480	6.3	208Y/120	8.3/14.5
			480Y/277	3.6/6.3
4.5	480Y/277	9.5/16.4	208Y/120	12.5/21.7
			480Y/277	5.4/9.4
	480	9.5	208Y/120	12.5/21.7
			480Y/277	5.4/9.4
6.0	480Y/277	12.6/22	208Y/120	16.7/28.9
			480Y/277	7.2/12.5
	480	12.6	208Y/120	16.7/28.9
			480Y/277	7.2/12.5
8.0	480Y/277	16.9/29.2	208Y/120	22.2/38.5
			480Y/277	9.6/16.7
	480	16.9	208Y/120	22.2/38.5
			480Y/277	9.6/16.7
10.0	480Y/277	21/36.5	208Y/120	27.8/48.2
			480Y/277	12/20.9
	480	21	208Y/120	27.8/48.2
			480Y/277	12/20.9
12.0	480Y/277	25.3/43.8	208Y/120	33.3/57.8
			480Y/277	14.5/25
	480	25.3	208Y/120	33.3/57.8
			480Y/277	14.5/25
16.0	480Y/277	33.7/58.4	208Y/120	44.5/77.1
			480Y/277	19.3/33.4
	480	33.7	208Y/120	44.5/77.1
			480Y/277	19.3/33.4
20.0	480Y/277	42.1/73	208Y/120	55.6/96.3
			480Y/277	24.1/41.7
	480	42.1	208Y/120	55.6/96.3
			480Y/277	24.1/41.7

KW	Input Voltage	Utility Feed Amps	Output Voltage	Max Output Amps
24.0	480Y/277	50.6/87.6	208Y/120	66.7/115.6
			480Y/277	28.9/50.1
	480	50.6	208Y/120	66.7/115.6
			480Y/277	28.9/50.1
30.0	480Y/277	63.2/109.6	208Y/120	83.4/144.5
			480Y/277	36.1/62.6
	480	63.2	208Y/120	83.4/144.5
			480Y/277	36.1/62.6
40.0	480Y/277	84.3/146.1	208Y/120	111.2/192.7
			480Y/277	48.2/83.5
	480	84.3	208Y/120	111.2/192.7
			480Y/277	48.2/83.5
60.0	480Y/277	126.4/219.1	208Y/120	166.7/298
			480Y/277	72.3/125.2
	480	126.4	208Y/120	166.7/298
			480Y/277	72.3/125.2
80.0	480Y/277	168.6/292.1	208Y/120	222.3/385.4
			480Y/277	96.3/166.9
	480	168.6	208Y/120	222.3/385.4
			480Y/277	96.3/166.9
100.0	480Y/277	210.7/365.2	208Y/120	277.9/481.7
			480Y/277	120.4/208.7
	480	210.7	208Y/120	277.9/481.7
			480Y/277	120.4/208.7
125.0	480Y/277	263.4/456.5	208Y/120	347.4/602.1
			480Y/277	150.5/260.8
	480	263.4	208Y/120	347.4/602.1
			480Y/277	150.5/260.8

Operation

Start Up

1. Check the input A.C. circuit breaker is off.
2. Check all output circuit breaker(s) (optional) are off.
3. Check the battery circuit breaker(s) are off.
4. Energize the utility feeder to the unit.
5. Turn input circuit breaker on (CB1).
6. Turn rectifier breaker on (CB2).
7. Wait for the system display message instructing you to close the battery breaker.
8. Turn on the battery circuit breaker (CB3).
9. Wait for the system display message stating that the unit is operational.
10. Turn on the output circuit breaker(s) (CB4).

◆ **WARNING:** Do Not overload the Emergency Lighting Inverter System. Refer to the wattage rating of the unit to ensure no overloading.

◆ **WARNING:** Failure to call for phone assistance for the initial start-up will void the warranty.

Turning System Off

1. Turn off the output circuit breakers (CB4).
2. Turn off the battery circuit breaker (CB3).
3. Turn off the rectifier breaker (CB2).
4. Turn off the input A.C. circuit breaker (CB1).

Manual Bypass

NOTE: Operation of the bypass switch will cause the static switch to utility bypass and turn off the inverter if it was running.

Battery Run Audible Alarm

(3-6KVA Only)

When the system is running on “Battery Backup” mode, the system will alarm. The alarm stops when the Emergency Lighting Inverter System returns to “Normal” mode operation.

Low Battery (Rapid Alarm)

(3-6KVA Only)

In the “Backup” mode, when the energy of the battery is 5% - 10%, the system will alarm until the system shuts down.

Direct Communications

(3-6KVA Only)

The Emergency Lighting Inverter System has an interface allowing direct communication via RS232, the location of which can be found on the front right hand door. See the system component diagram exact location. Please see the “interface” section for more information.

Maintenance

Factory-trained personnel should perform maintenance only. Factory training is available. Training can be done on-site, over the phone or at the factory. Do not attempt to service. Various maintenance contracts are available; please contact “customer service” for more details.

Technical Support

For technical support or help with any questions not covered in the manual, contact:

DSPM Inc.
1921 S. Quaker Ridge Place
Ontario, CA 91761

Work Hours: 8 a.m. – 5 p.m. Pacific Standard Time
Phone: 1.877.DSPM.POWER
1.877.377.6769

After Hours: 5 p.m. – 1 a.m. Pacific Standard Time
951.840.0811

Fax: 909.930.3335

techsupport@dspmanufacturing.com

Battery Connections

Please see the inside door of your unit to see the battery layout. Battery interconnects are provided by factory. Cabinet interconnects provided by other (if applicable). If you have any further questions about battery connections please contact DSPM.

Environmental Control Module

