

# Earthquake Tactile Transducers



Quake 10.0

Mini Quake

## Users Manual

# Earthquake® Tactile Transducers Basic Information

By now, you may have some knowledge about Tactile Transducers. To help clarify this application further, please read on:

## What is a Tactile Transducer?

A tactile transducer or "bass shaker" is a device which is made on the principle that low bass frequencies can be felt as well as heard. A shaker transmits low-frequency vibrations into various surfaces so that they can be felt by people. This is called tactile sound. Tactile transducers may augment or in some cases, substitute for a subwoofer.

Tactile transducers may be used in a home theater, a commercial movie theater, or for special effects in an arcade game, amusement park ride or other application.

### In Home Theater and Music Applications:

A surround sound audio system complements a video action movie by responding to the events that are unfolding on the screen. The surround sound extends from 30 Hz (if you are lucky) and up to 20Khz. For the most part, it is the low frequency response that brings you closer to the action. A tactile transducer system will tap into the low frequency signal that is emanating for LFE output, which is typically located in the back of your receivers. This signal is amplified through a resilient power amplifier and then used to drive the tactile transducer; Thus, picking up and enhancing everything your subwoofer lacks.

### In Gaming Applications:

Tactile transducers are an explosive way to generate massive vibration, which brings players into the video game. Mounting a Mini Quake in a gamer seat will lead to an incredible interactive experience unlike any other.

### In Music Applications:

Music recording can be immensely enhanced by allowing musicians (drummers in particular) who rely on sound and impact to literally feel their progress while recording. Now, musicians can rely on tactile transducers to transmit vibrations through their seats. This vibration allows them to feel the beat more naturally and confidently synchronize it with others in the band.

## Mounting Quake Tactile Transducers

The Earthquake® Quake 10.0 and Mini Quake need to be mounted vertically at all times. Mounting them vertically maximizes the output and increases the over all tactile experience.

Horizontally mounting the units will diminish the output and may damage them over time.

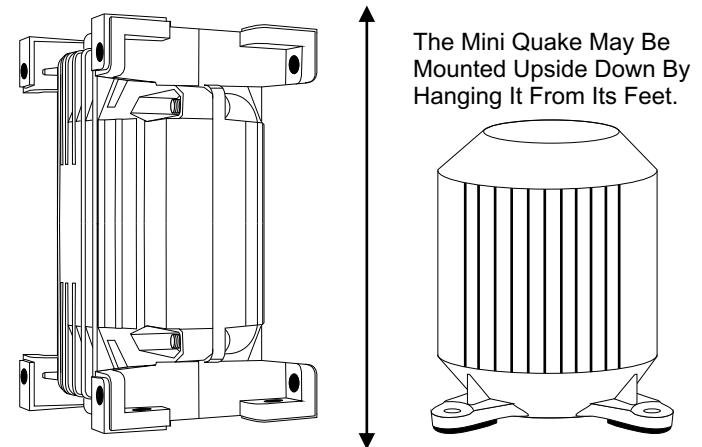

# How To Connect to an Amplifier

## Equipment that will be needed for installation:

- "Y" Connector to apply from receiver or pre-amp to the XJ-600R
- Minimum 12-gauge speaker cable.

## XJ-600R CONNECTION OPTIONS

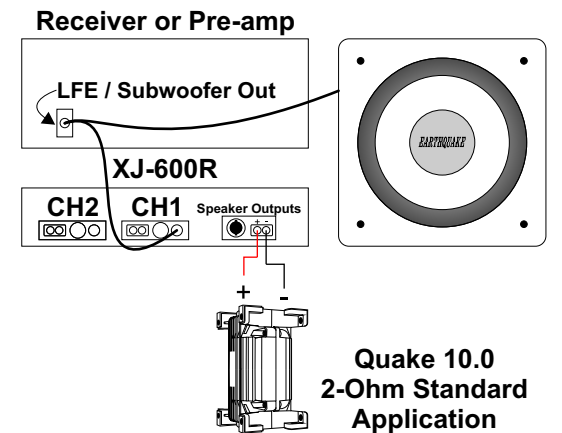
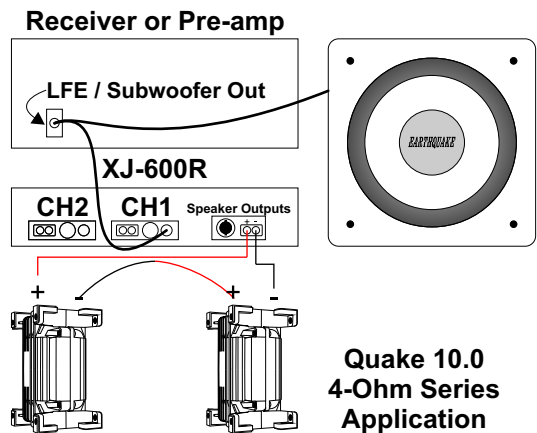
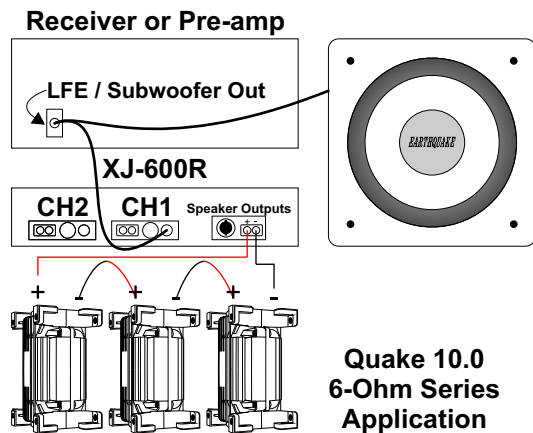
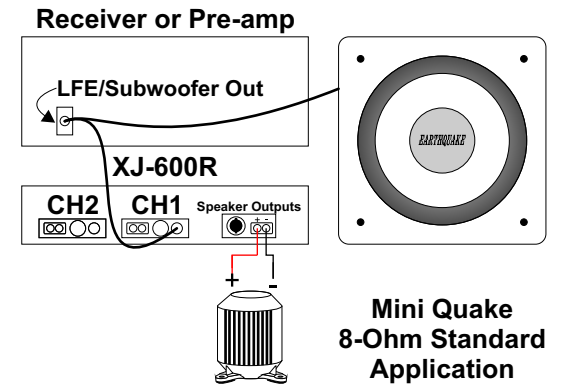
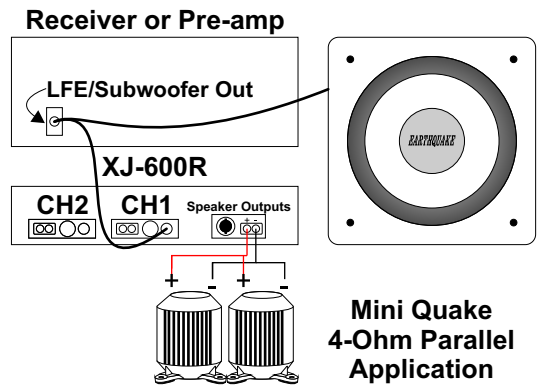
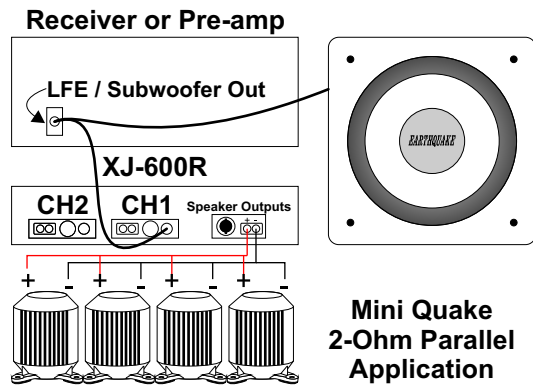

# How To Connect to an Amplifier

## Equipment that will be needed for installation:

- "Y" Connector to apply from receiver or pre-amp to the XJ-300R
- Minimum 12-gauge speaker cable.

## XJ-300R CONNECTION OPTIONS

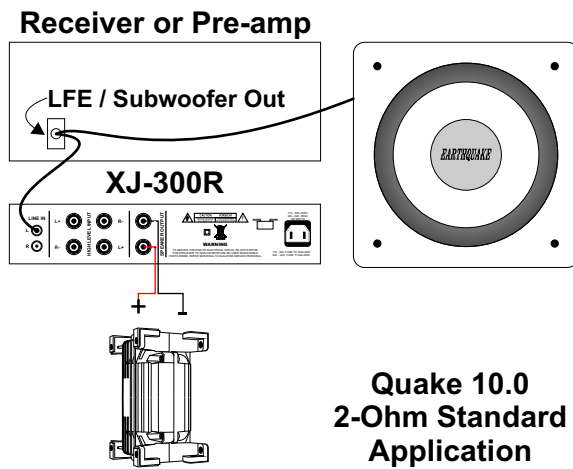
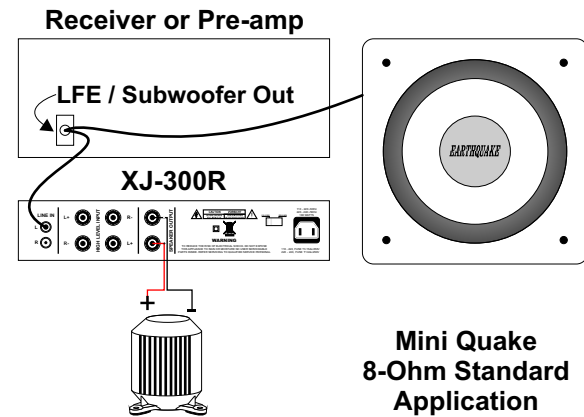
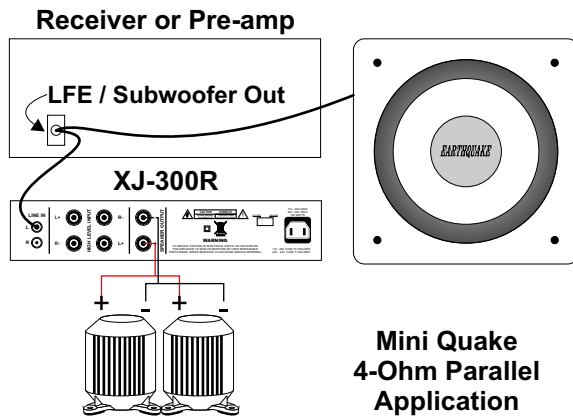

# Recommended XJ-600R / XJ-300R Front Panel Settings

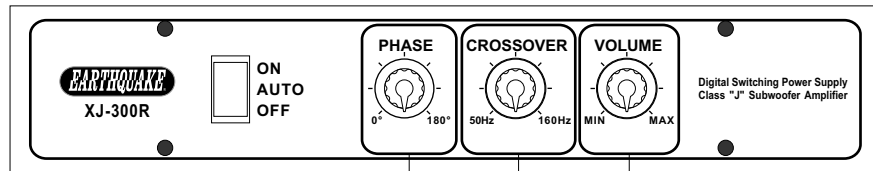
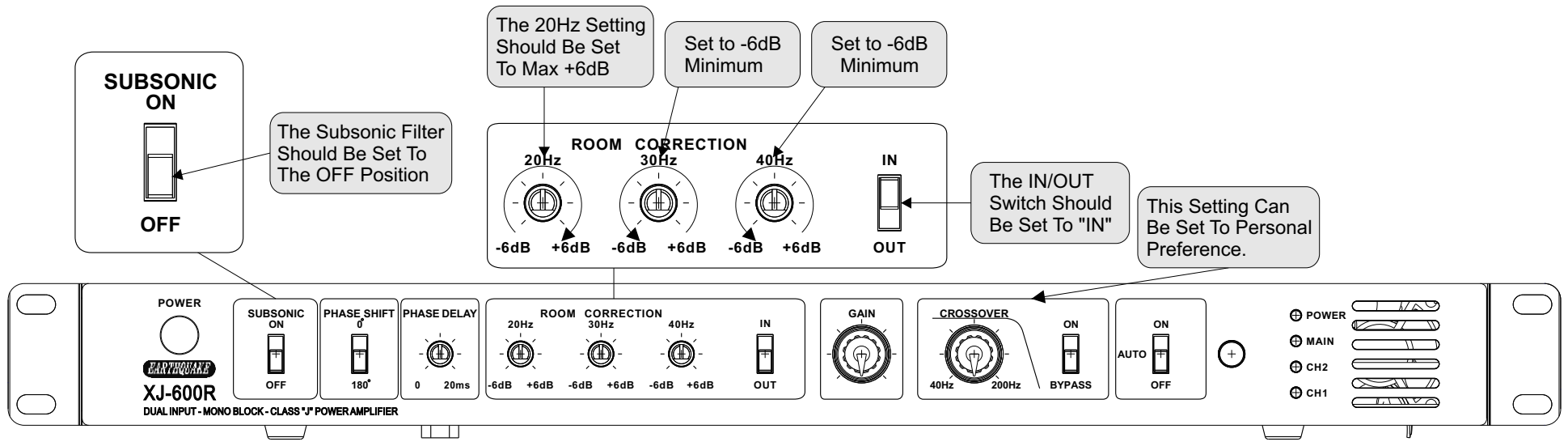

**Phase Control** - Since your subwoofer is at some distance from your chair, the sound will take a certain amount of time to reach your ears. The signal arriving at the shaker is instantaneous by comparison. The Phase Control lets you delay the signal reaching the Quake shaker so that it will shake at exactly the same time as the low frequency sound from your subwoofer arrives at your ears. To make the adjustment, simply play a low frequency test tone through your subwoofer and shaker (most receivers have test tone generators for adjusting the volume of all the channels, including the subwoofer). Then, sit in the chair or couch where you have attached the shaker, with the XJ-300 amplifier close at hand, and adjust the Phase Control so that the sound and the tactile sensations appear to be synchronized. Note that you can get an "additional channel effect" by simply adjusting the phase control so the sound and the tactile sensations are as out of synchrony as possible. In other words, adjust the Phase Control so that it gives you the effect you want.

**Crossover Control** - The idea is to have your chair or couch shake with certain movie special effects, but not with someone slamming a door (unless you want it to). This is where the Crossover Control comes into play. Depending on how high you have set the Volume Control, you should adjust the Crossover Control so that it is only shaking with the sound effects that you want, and not with every loud noise that occurs on screen. Start by setting the Crossover Control at its lowest point, i.e., 50 Hz, which is fully counter clockwise. Then, with some special effects scenes from one of your favorite movies (the attack scene from Pearl Harbor is great for this purpose), adjust the Crossover Control so that you get the shaking effect just with the explosions, crashes, and gunfire. If you adjust the Crossover Control too high, you will be shaking with such things as deep voices, and that may or may not be what you want.

**Volume Control** - First of all, when you turn on your new XJ-300 amplifier, make sure the Volume Control is at the lowest setting possible (fully counter clockwise). Then, as you play test tones or watch movies, adjust the Volume Control so that you feel the Quake shaking your chair or couch with the test tone, or in the case of movies, when special low frequency effects such as explosions, machine guns, or such large machines as army tanks (isn't it great to be a guy?) occur on-screen. Note that the XJ-300 is very powerful, and you will probably not need to turn the volume up all the way (you may need to adjust the volume of the subwoofer output on your receiver so that the input on the XJ-300 receives enough signal to drive it properly).

# How To Mount Directly To Furniture

## Applications

- ✓ Sofas
- ✓ Theater Chairs
- ✓ Recliners

## Mounting

- ✓ Direct
- ✓ Multiplier
- ✓ Internally
- ✓ Externally

## Enhancements

- ✓ Home Theater
- ✓ Music

### Mini Quake Side Mount Multiplier

Back of Sofa

Mini Quake

Mini Quake,  
Side Mount Multiplier

Strongest Joist / Brace  
in Sofa or Chair

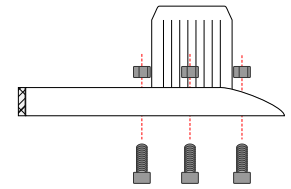
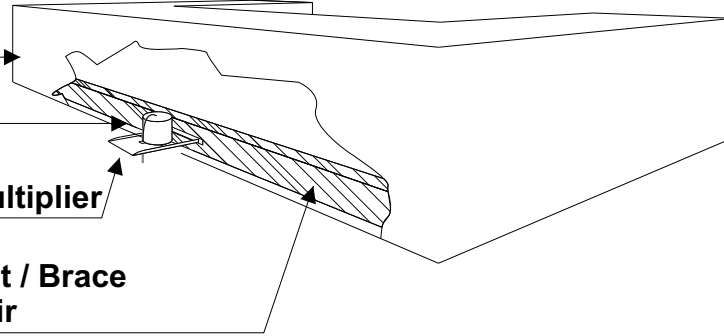

### Quake-10.0 Side Mount Multiplier

Back of Sofa

Quake-10.0

Quake-10.0  
Side Mount Multiplier

Strongest Joist / Brace  
in Sofa or Chair

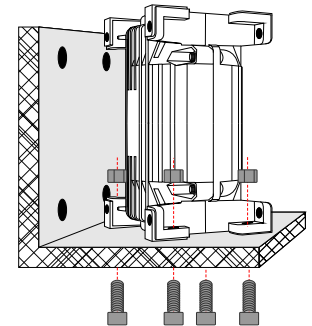
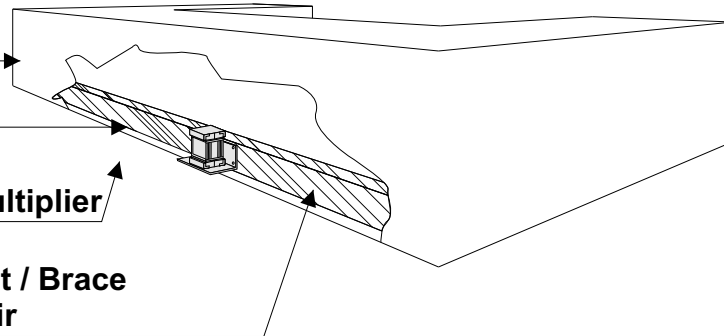

## Multiplier Options

Quake 10.0 / Mini Quake  
Side Mount Multiplier

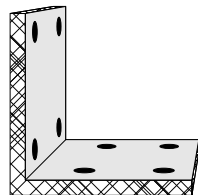

Mini Quake  
Side Mount Multiplier

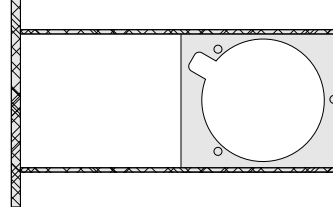

# How To Mount To a Platform

## Applications

- ✓ Sofas
- ✓ Theater Chairs
- ✓ Recliners

## Mounting

- ✓ Direct
- ✓ Multiplier
- ✓ Internally
- ✓ Externally

## Enhancements

- ✓ Home Theater
- ✓ Music

## Multiplier Options

When designing your custom platform, be sure to allow 1-1/2 to 2 feet of space around the outer perimeter of the chairs or couch. This much space is not required in between the chairs.

All platforms should be constructed with no less than 1/2" plywood and built sturdy for some seriously high speed entertainment. Also, the use of rubber stabilizers is an excellent way to eliminate rattles and vibrations that may cause valuables to fall off the walls or shelves. In addition, the rubber feet will provide a great suspension, allowing the Quake 10.0 to really shine.

The optional Platform Mount Multiplier can be installed underneath or inside couches or chairs as in previous illustrations, but it is more effective when mounted directly to the platform. Once the Multiplier is mounted to the platform, you may then move a chair or couch over it for a more plush cosmetic appearance.

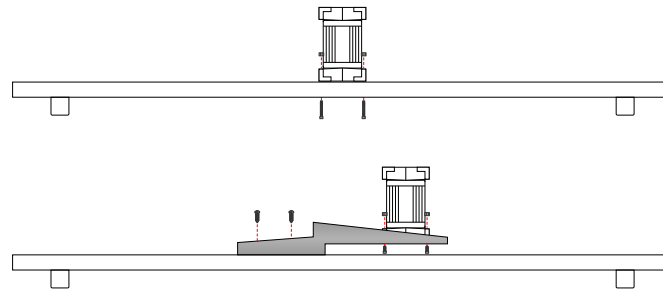
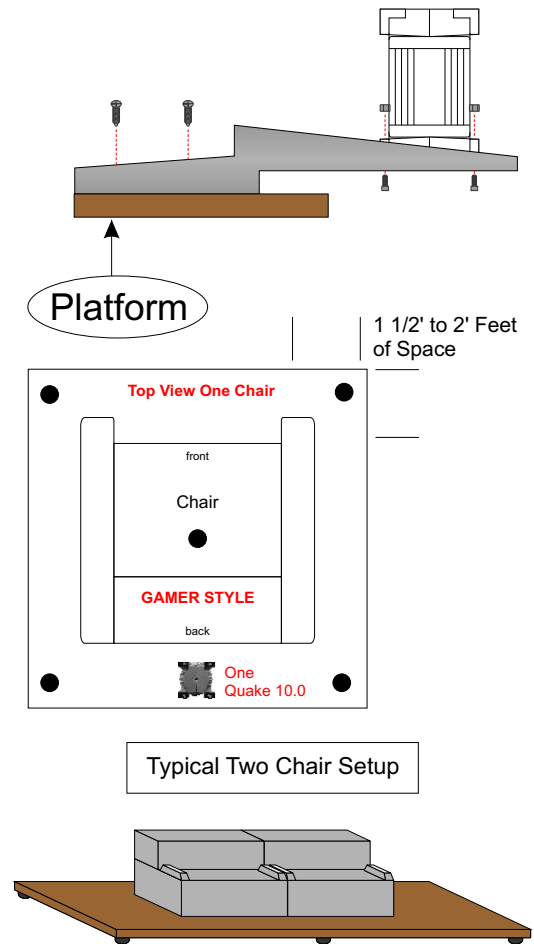

### Quake 10.0 Platform Multiplier

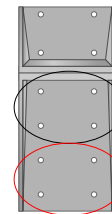

Reduce intensity by mounting the Quake here.

Get a higher intensity by mounting the Quake here.

# How To Mount To a Platform

## Applications

- ✓ Office Chairs
- ✓ Thrones
- ✓ Game Chairs

## Mounting

- ✓ Direct
- ✓ Multiplier

## Enhancements

- ✓ Gaming
- ✓ Music
- ✓ Music Recording

## Multiplier Options

### Mini Quake Gaming Multiplier

Rotating Chair or Throne

Rotating Chair Pole Piece

Mini Quake

Mini Quake, Gaming Multiplier

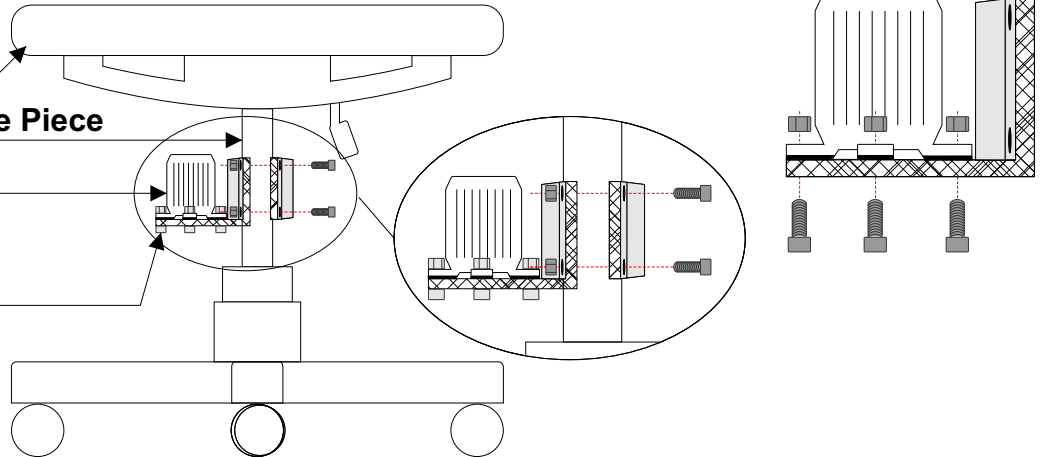

### Mini Quake Gaming Multiplier

Pre-built gaming chairs come in all different shapes and sizes. The illustration to the right is only a demonstration on how you may install a Mini Quake to this type of application.

Always be sure that what you are mounting the bracket to is very solid and won't pierce any pre-existing wiring or damage the chair's upholstery.

In addition, please keep in mind that the Mini Quake is very powerful and will deteriorate poorly constructed chairs, thrones, etc. You may even need to modify existing construction.

Pre-built Gamer Chair

Mini Quake, Gaming Multiplier  
(Minus the Second Half of The Bracket)

Mini Quake

Strongest, Mountable Area on Chair (This Will Vary From Chair to Chair)

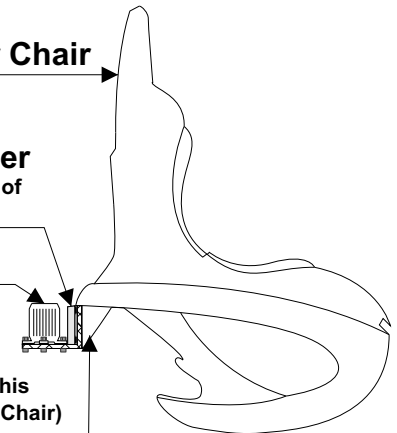

### Mini Quake Gaming Multiplier

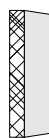
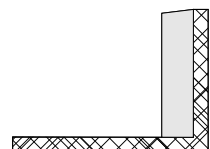

First Half



Second Half





## Mini Quake Specifications:

- 15 - 50Hz frequency response
- 8 $\Omega$  impedance
- 20-500 Watts
- Dimensions:
  - H = 3 1/2" • 88.9mm
  - W = 3 1/8" • 79.375mm
  - D = 3 1/8" • 79.375mm

## Quake 10.0 Specifications:

- 5 - 40Hz frequency response
- 2 $\Omega$  impedance
- 40-1000 Watts
- Dimensions:
  - H = 3 9/16" • 90.4875mm
  - W = 6 3/16" • 157.1625mm
  - D = 3 9/16" • 90.4875mm

## PRODUCT SUPPORT:

Please contact Earthquake Sound Technical Support Department for questions regarding your Tactile Transducer.

Earthquake Sound Corporation  
1-800-576-7944, 9:00 am - 5:00 pm Mon-Fri, Pacific Time  
Email us at: [techsupport@earthquakesound.com](mailto:techsupport@earthquakesound.com)

## PRODUCT REGISTRATION

This product can be registered by returning the Product Registration card attached to this manual or by visiting

[www.earthquakesound.com/form\\_reg.htm](http://www.earthquakesound.com/form_reg.htm)

Please also retain the bill of sale, which represents proof of purchase this will ease the flow of service and allow us to expedite your products servicing much quicker than without one. Also, bare in mind that any products purchased via an UNAUTHORIZED EARTHQUAKE DEALER will not be honored any warranty. You will have to pay full service pricing, these guidelines are outlined in the warranty section of this manual.

Earthquake Sound Corporation  
1-800-576-7944, 9:00 am - 5:00 pm Mon-Fri, Pacific Time  
2727 McCone Avenue Hayward, CA 94545, USA  
Email us at: [tech@earthquakesound.com](mailto:tech@earthquakesound.com)

### **Limited 5-Year Warranty**

Earthquake warrants the original purchaser that all Factory Sealed New Audio Products to be free from defects in material and workmanship under normal and proper use for a period of five (5) years from the date of purchase (as shown on the original bill of sale with serial number affixed/written on it). The five (5) year warranty period is valid only if an authorized Earthquake dealer properly installs the product and the warranty registration card is properly filled out and sent to Earthquake Sound Corporation. If a non-authorized party installs the product, a ninety (90) day warranty period will be applied.

#### **(A) Five (5) years limited warranty plan coverage guidelines:**

- **First year:** Earthquake pays for labor, parts, and ground freight (only in US mainland, not including Alaska and Hawaii. Shipping to us is not covered).
- **Second year:** Earthquake pays for labor only, customer must pay freight both ways.
- **Third, fourth & fifth year:** Earthquake pays labor only. Customer must pay for parts and freight both ways.

#### **(B) Warning:**

Products (sent for repair) that are tested by Earthquake technicians and deemed to have no problem(s) will not be covered by the five (5) year limited warranty. Customer will be charged a minimum of one (1) hour of labor (at the ongoing rates) plus shipping charges back to customer.

#### **(C) Earthquake will repair or replace at our option all defective products/parts subject to the following provisions:**

- Defective products/parts have not been altered or repaired by other than an Earthquake factory-approved technicians.
- Products/parts are not subjected to negligence, misuse, improper use or accident, damaged by improper line voltage, used with incompatible products or have its serial number or any part of it altered, defaced or removed, or have been used in any way that is contrary to Earthquake's written instructions.

#### **(D) Warranty Limitations:**

Warranty does not cover products that have been modified or abused, including but not limited to the following:

- Damages to speaker cabinet and cabinet finish due to misuse, abuse or improper use of cleaning materials/methods.
- Bent speaker frame, broken speaker connectors, holes in speaker cone, surround & dust cap, burnt speaker voice coil.
- Fading and/or deterioration of speaker components & finish due to improper exposure to elements.
- Bent amplifier casing, damaged finish on the casing due to abuse, misuse or improper use of cleaning material.
- Burnt tracers on PCB.
- Product/part damaged due to poor packaging or abusive shipping conditions.
- Subsequent damage to other products.

A warranty claim will not be valid if the warranty registration card is not properly filled & returned to Earthquake with a copy of the sales invoice. Warranty card is located on the last page of this manual.

#### **(E) Service Request:**

To receive product service, contact Earthquake Service Department at (510) 732-1000 and request an RMA number (Return Material Authorization). Items shipped without a valid RMA number will be refused. Make sure you provide us with your complete/correct shipping address, a valid phone number, and a brief description of the problem you are experiencing with the product. In most cases, our technicians might be able to resolve the problem over the phone; Thus, eliminating the need to ship the product.

#### **(F) Shipping Instructions:**

Product(s) must be packaged in its original protective box(es) to minimize transport damage and prevent repackaging cost (at the ongoing rates). Shipper claims regarding items damaged in transit must be presented to carrier. Earthquake Sound Corporation reserves the right to refuse improperly packed product. Original bill of sale must accompany product returned to service. We encourage you to include with the package a written description of the problem. Ship product to: Earthquake Sound Corp. 2727 McCone Avenue, Hayward, CA 94545. Ph: (510) 732-1000. You are responsible for the cost of shipping the product to Earthquake Sound Corporation.

#### **(G) Disputes Resolution:**

All disputes between clients and Earthquake Sound Corporation resulting from the five (5) year limited warranty policy must be resolved according to the laws & registration of the county of Alameda California.





*Sound That Will Move You.*

**Earthquake Sound Corporation**  
1-800-576-7944, 9:00 am - 5:00 pm Mon-Fri, Pacific Time  
2727 McCone Avenue Hayward, CA 94545, USA  
[www.earthquakesound.com](http://www.earthquakesound.com)