



WT-204 GSM Wireless Terminal (4 Ways)

WITURA CORPORATION SDN BHD

Office Address: 18-8-C, Gurney Tower, Persiaran Gurney, 10250 Penang, Malaysia. Tel: 604 - 228 9053 Fax: 604 – 228 9054
URL: [http:// www.witura.com](http://www.witura.com) Email: sales@witura.com

Features

- Adopts advanced microprocessor controlling circuit, runs steadily and its functions are all complete
- Enhanced high gains external antenna
- Be suitable to GSM900/1800MHz
- Locking terminal, locking SIM card and locking network can be set up flexibly.
- Diversiform function on calling out or being called in can be set according to your need
- Display incoming calls
- Barred telephone numbers can be set flexibly
- Prefixal code can be set according to user's requirement
- Can be connected to charging device
- Can be connected to PBX
- With the function of network management, the parameters can be set through network manager



The Frontal Appearance of WT-204

The instructions to the frontal appearance of WT-204

Indicators and knobs (from up to down)

- Status indicator—flashing once in one second indicates that the terminal has been on GSM network
- Used indicator —Staying lit during calls and during parameters' setting
- Warn indicator—Staying lit for less than 10 seconds indicates that the terminal is dealing with SMS. If it stays lit for more than 10 seconds, there is some trouble with the terminal.
- Reset knob — press this knob, its corresponding board will reset.
- Power switch—push to “On” or “OFF” side to turn on or shut off the terminal.



The Rear Appearance of WT-204

Instructions to the rear appearance of WT-204

- Power port—connect to power adapter
- Phone port—connect to a phone
- Antenna port—connect to antenna

WITURA CORPORATION SDN BHD

Office Address: 18-8-C, Gurney Tower, Persiaran Gurney, 10250 Penang, Malaysia. Tel: 604 - 228 9053 Fax: 604 – 228 9054
URL: [http:// www.witura.com](http://www.witura.com) Email: sales@witura.com

Installing the SIM Card

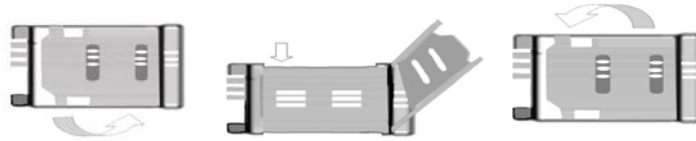

Proceed as follows:

- Slide back the SIM door and lift it up
- Slide the SIM card into the SIM door making sure that the clipped corner of the SIM card lines up with the clipped corner of the SIM holder
- Close the SIM door
- Slide the SIM door to lock the SIM card in place

Setting up the Terminal

The Condition for Installation

The terminal asks for 220V AV power supply. It must be installed in the area where the GSM network can cover. The strength of the signal can affect the quality of voice direct.

The Installation for Connect to Ordinary Telephone

- Screw off the screws that are on the back of the terminal and pull out the corresponding circuit board. Install SIM card for every circuit board and install the circuit board in place, and then tighten the screws.
- Install antenna. In order to ensure the quality of voice, antenna must be put beyond 1.5m from the telephone and terminal.
- One end of the telephone line connects to the “Phone” port of the terminal, the other end connects to telephone.
- “Power” port connects to power adapter that is connected to 220V AC power supply. About 15—45 seconds later (the time is subject to local wireless network), the terminal will work in gear.

The sketch for connecting to ordinary telephone: each circuit board can be connected to one telephone

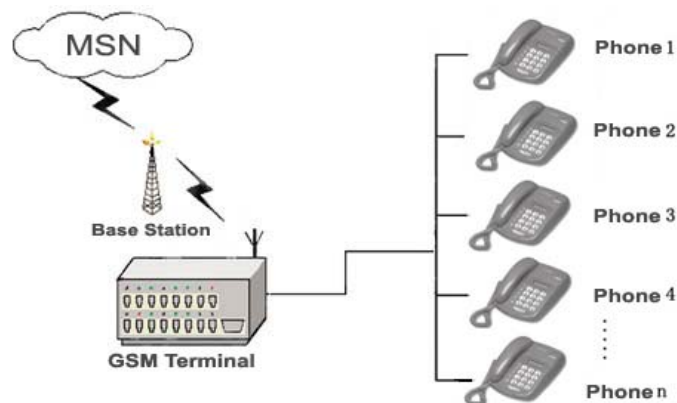

Draw your attention: Because there are many types of ordinary telephone and their electric parameters are different. In order to avoid mutual disturbance between telephone and terminal and affect voice quality. The distance between telephone and terminal is 1.5m at least.

WITURA CORPORATION SDN BHD

Office Address: 18-8-C, Gurney Tower, Persiaran Gurney, 10250 Penang, Malaysia. Tel: 604 - 228 9053 Fax: 604 - 228 9054
URL: <http://www.witura.com> Email: sales@witura.com

The installation connecting to charging device

If the users demand to register cost during calls, charging device can be connected between terminal and ordinary telephone. Charging device register cost according to the anti-polarity signal that is provided by terminal.

1. The sketch map of connecting multi-route charging device

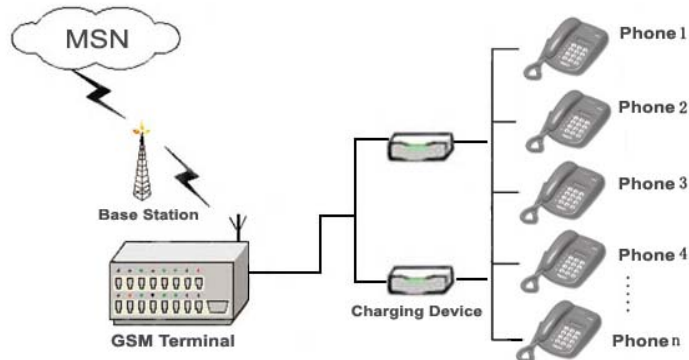

2. The sketch map of connecting to computer charging system

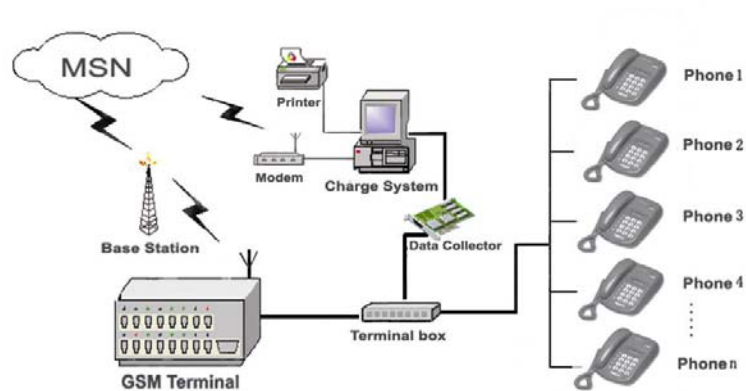

The installation for connecting to PBX

If users want to connect small PBX to this terminal, connect terminal's "Phone port" to the PBX.

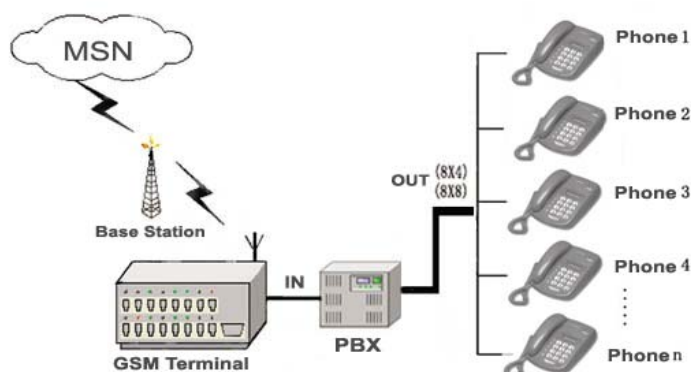

Making Calls and Answer Incoming Calls

Making Calls

1. Lift the handset or press “hand-free” key, you will hear dialing tone, then you can dial the telephone numbers you want to call.
2. Dialing: dialing the telephone numbers you want to call
3. On completion of dialed digits, you can press “#” to transmit the called telephone numbers. If you don't dial any key for continual 6 seconds during the dialing, terminal transmits called telephone numbers automatically.
4. During calls, if the telephone numbers is not free ones, the terminal sends out anti-polarity signal (the signal is used to register cost by charging device).
5. If the calling party or called party hangs up, the terminal stops sending out anti-polarity signal.
6. If users dial barred numbers telephone will give out the sound of three-time toot to ask the user to hang up.

Answering Incoming Calls

When some calls are coming in, if the connected telephone has the function of displaying incoming calls, the telephone rings and displays the incoming telephone numbers. Now users can lift the handset or press “hand-free” to answer it.

Turn on or turn off the terminal

Put power switch to “OFF” side to turn off the terminal and put the power switch to “ON” side to turn on the terminal.

The Information about Signal Quality, Malfunction and Software Version

If the connected phone has the function of displaying incoming calls, the telephone rings after the terminal is login onto GSM network successfully and a code of 8 digits will be displayed .The code indicates the information about signal quality, malfunctions and software version as follows:

The first two digits indicate the signal quality; it ranges from “00” to “31”. Stronger the signal is, bigger the digits is. If it is less than 10, the quality of voice will be poor.

WITURA CORPORATION SDN BHD

Office Address: 18-8-C, Gurney Tower, Persiaran Gurney, 10250 Penang, Malaysia. Tel: 604 - 228 9053 Fax: 604 – 228 9054
URL: [http:// www.witura.com](http://www.witura.com) Email: sales@witura.com



The third and the fourth digit is the code of malfunction:

“00”: good “11”: failed in login onto GSM network
“22” or “33”: PIN error (PIN code isn’t 1234 or PIN isn’t disabled),
“44”: lock card error, “55”: lock terminal error
“77”: lock network error, “99”: read card error

The later four digits is the code of software version: for example 4060 indicates the software version code is 4.06.

If the telephone displays “11” or “22” or “33” or “44” or “77” or “99” or the telephone can’t work in gear, please contact service provider.

Inquire Signal Quality and Software Version

Lift the handset and then dial “**9#”. Hang up as soon as you hear the busy tone. The telephone rings and displays a code of 8 digits. The code indicates the information of signal quality and software version as follows:

The first two digits indicate signal quality. It ranges “00” to “31”. Stronger the signal is, bigger the digits is. If it is less than 10, the quality of voice will be poor.

The third and the fourth digits are both standby.

The later four digits is the code of software version: for example 4060 indicates the software version code is 4.06.

Adjusting the Volume of Voice

Lift the handset or press “hand-free” key.

Dial “*33XY#” and then hang up when hear the sound of toot.

X and Y both belong to the digits that range from 1 to 5. X indicates microphone volume and Y indicates speaker volume. Level 1 is the lowest volume and level 5 is the highest.

WITURA CORPORATION SDN BHD

Office Address: 18-8-C, Gurney Tower, Persiaran Gurney, 10250 Penang, Malaysia. Tel: 604 - 228 9053 Fax: 604 – 228 9054
URL: <http://www.witura.com> Email: sales@witura.com

The Instructions for Terminal's Running Status

1. The instruction for initializing terminal
2. When Power indicator is lit, the terminal begins to initialize. If Status indicator and Used indicator are flashing simultaneously, the terminal is searching for network. About 15~45 seconds later, the telephone rings that indicates the process of initialization terminal finishes. If Warn indicator stays lit, initialization is unsuccessful. On this condition user can set parameters for the terminal but the terminal can't be used to make any calls. If users dial telephone numbers, the Warn indicator will flash and the telephone will give out the sound of three-time toot to ask the user to hang up.
3. While users dialed barred numbers or other error numbers, the telephone gives out the sound of three-time toot to indicate that user should hang up and redial.
4. While you are lifting the handset and don't dial any key for continuous 15 seconds or nobody answer the dialed telephone for 90 seconds after the called telephone has ringed, the telephone will give out the sound of three-time toot to indicate the user to hang up. If the user doesn't hang up for a long time, all indicating sound will stop after 1 minute.
5. While calls coming in, Used indicator flashes. IF user answers the call, the Used indicator stays lit until the call is hung up.
6. When user is lifting the handset, Used indicator stays lit until user hangs up.
7. When the terminal receives SMS, Warn indicator and Used indicator both stay lit that indicates that the terminal is dealing with SMS.
8. If Warn indicator stays flashing and the telephone continuously gives out the sound of three-time toot, which indicates that the terminal is on the warning status. Please hang up.

Technical Specification

1. Working condition
Environment temperature: 0~+50°C
Relative humidity: 10%~95%
Air pressure: 86~106kpa
Environment yawp: ≤60Db (A)
2. Working frequency: GSM900/GSM1800MHz
3. Stability of frequency: better than 2.5PPM
4. Signal sensitivity: -103DbM
5. Transmit power: <2w
6. Power Supply: 220v ± 15% AC
7. The maximal distance between terminal and telephone: 100M

Maintenance and storage

1. The terminal should be saved in the desiccant place.
2. If there are some matters with the terminal, please send it to the appointed repair center. (The damages that are caused by error operation are beyond the scope of our free maintenance). Don't take apart the terminal by yourself without our agreement
3. The packed terminal should be put in dry and ventilated place. The number of layers of piled terminal can't more than 10. The condition of the storehouse is listed as follows:
Temperature: -10 to +45°C Relative humidity: ≤95%
You should ensure that there is no corrosive gas in the storehouse too.

Familiar Trouble and Troubleshooting

WITURA CORPORATION SDN BHD

Office Address: 18-8-C, Gurney Tower, Persiaran Gurney, 10250 Penang, Malaysia. Tel: 604 - 228 9053 Fax: 604 - 228 9054
URL: <http://www.witura.com> Email: sales@witura.com

| Phenomena | Trouble | Trouble Shooting |
|---|--|--|
| Warn indicator stay bright for long time | Failed in login onto GSM network | <ol style="list-style-type: none"> 1. The signal is too weak Please move the terminal to the place where signal is stronger. 2. Check whether antenna is connected well. 3. SIM card is locked. Please contact the service provider. |
| Power indicator isn't bright | Having not connect to power supply | <ol style="list-style-type: none"> 1. Check whether the adapter is connected well. 2. There is some trouble with the power adapter Please contact the terminal provider. |
| Only free numbers can be called out | The residual money on SIM card is too less | Add money to the SIM card |
| Can't hear of sound during calls | The malfunction on the telephone | Change the connected telephone with a good one |
| Poor voice quality during calls or there is echo during calls | The voice volume is too high or the signal of GSM network is too weak. | <ol style="list-style-type: none"> 1. Adjust the voice volume to be lower. 2. The local signal is too weak. Move the terminal to the place where signal is stronger. 3. Make the antenna is longer from the telephone 4. The voice quality of the connected telephone isn't good. Change the connected telephone 5. Trouble on the network. |
| No ringing sound | The malfunction on the telephone | <ol style="list-style-type: none"> 1. Malfunction on connected telephone 2. Malfunction on terminal. Please contact the terminal provider. |
| Incoming calls can't be answered | The connected telephone does not match the terminal or forbidding answering incoming calls are set | <ol style="list-style-type: none"> 1. Chang the connected telephone with a suitable one. 2. Forbidding answering incoming calls is set. Please contact the service provider. |

WITURA CORPORATION SDN BHD

Office Address: 18-8-C, Gurney Tower, Persiaran Gurney, 10250 Penang, Malaysia. Tel: 604 - 228 9053 Fax: 604 – 228 9054
 URL: [http:// www.witura.com](http://www.witura.com) Email: sales@witura.com