

**OPERATING INSTRUCTIONS • ISTRUZIONI D'USO
NOTICE D'UTILISATION • BEDIENUNGSANLEITUNG
INSTRUCCIONES DE USO**

MONO SPLIT

**MTA8FIA0R5I--
MTA8FBI0R5I--**

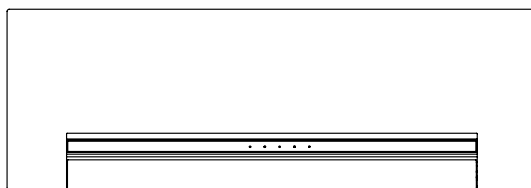

MULTI SPLIT

**MTAFIA0R5I--
MTAFBI0R5I--**

MONO/MULTI SPLIT

KPA8FIA0R5I--

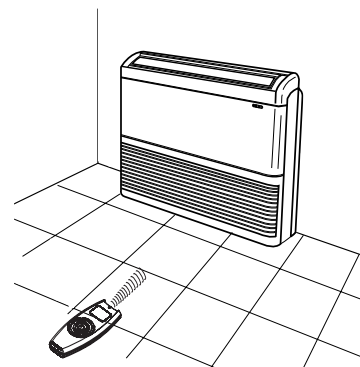
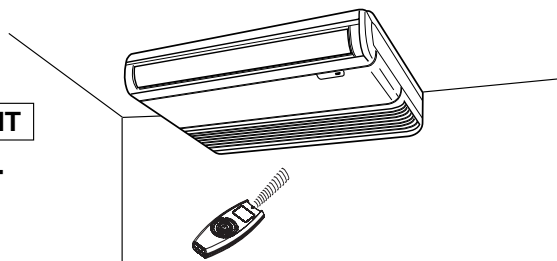

MONO/MULTI SPLIT

CA8FIA0R5I--

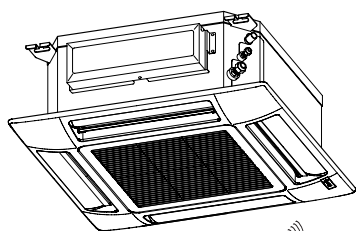

MONO/MULTI SPLIT

SDA8FIA0R5I--

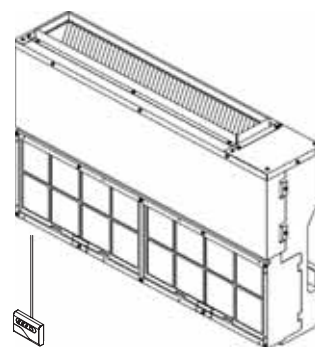

**Split air conditioner system • Condizionatore d'aria split system
Climatiseurs split • Split-klimagerät
Acondicionador de aire de consola partida sistema split •
ΔΙΑΙΡΟΥΜΕΝΕΣ ΜΟΝΑΔΕΣ ΚΛΙΜΑΣΜΟΥ**

CONTENTS

NAME OF PARTS AND OPERATION SELECTOR SWITCH	3
INSTALLATION LOCATION	5
ELECTRICAL REQUIREMENTS	5
SAFETY INSTRUCTIONS	5
USING THE REMOTE CONTROL UNIT	5
REMOTE CONTROL UNIT	6
HOW TO SET THE PRESENT TIME	7
COOLING	7
HEATING	7
AUTOMATIC OPERATION	7
DEHUMIDIFYING (DRY)	7
FAN ONLY	8
ADJUSTING THE FAN SPEED	8
FILTER TiO ₂	8
NIGHT MODE/ENERGY SAVING	8
HIGH POWER MODE	8
SETTING THE TIMER	9
SETTING THE 1 HOUR TIMER	9
ADJUSTING THE AIR FLOW DIRECTION	9
OPERATION WITHOUT THE REMOTE CONTROL UNIT	11
CARE AND CLEANING	11
TIPS FOR ENERGY SAVING	13
TROUBLESHOOTING	14

PRODUCT INFORMATION

If you have problems or questions concerning your Air Conditioner, you will need the following information. Model and serial numbers are on the nameplate on the bottom of the cabinet.

Model No. _____

Serial No. _____

Date of purchase _____

Dealer's address _____

Phone number _____

ALERT SYMBOLS

The following symbols used in this manual, alert you to potentially dangerous conditions to users, service personnel or the appliance:



WARNING

This symbol refers to a hazard or unsafe practice which can result in severe personal injury or death.



CAUTION

This symbol refers to a hazard or unsafe practice which can result in personal injury or product or property damage.

NOTE

This air conditioner is equipped with cooling, drying, heating and fan only functions.

Details on these functions are provided below; refer on these descriptions when using the air conditioner.

DECLARATION OF CONFORMITY

This product is marked  as it satisfies Directives:

– Low voltage no. 2006/95/CE.

– Electromagnetic Compatibility no. 89/336 EEC, 92/31 EEC and 93/68 EEC.

This declaration will become void in case of misuse and/or from non observance though partial of Manufacturer's installation and/or operating instructions.



INFORMATION FOR CORRECT DISPOSAL OF THE PRODUCT IN ACCORDANCE WITH THE EUROPEAN DIRECTIVE 2002/96/EC

At the end of its working life this equipment must not be disposed of as an household waste.

It must be taken to special local community waste collection centres or to a dealer providing this service.

Disposing of an electrical and electronic equipment and its batteries separately avoids possible negative effects on the environment and human health deriving from an inappropriate disposal and enables its components to be recovered and recycled to obtain significant savings in energy and resources.

In order to underline the duty to dispose of this equipment and batteries separately, the product is marked with a crossed-out dustbin.

NAME OF PARTS AND OPERATION SELECTOR SWITCH

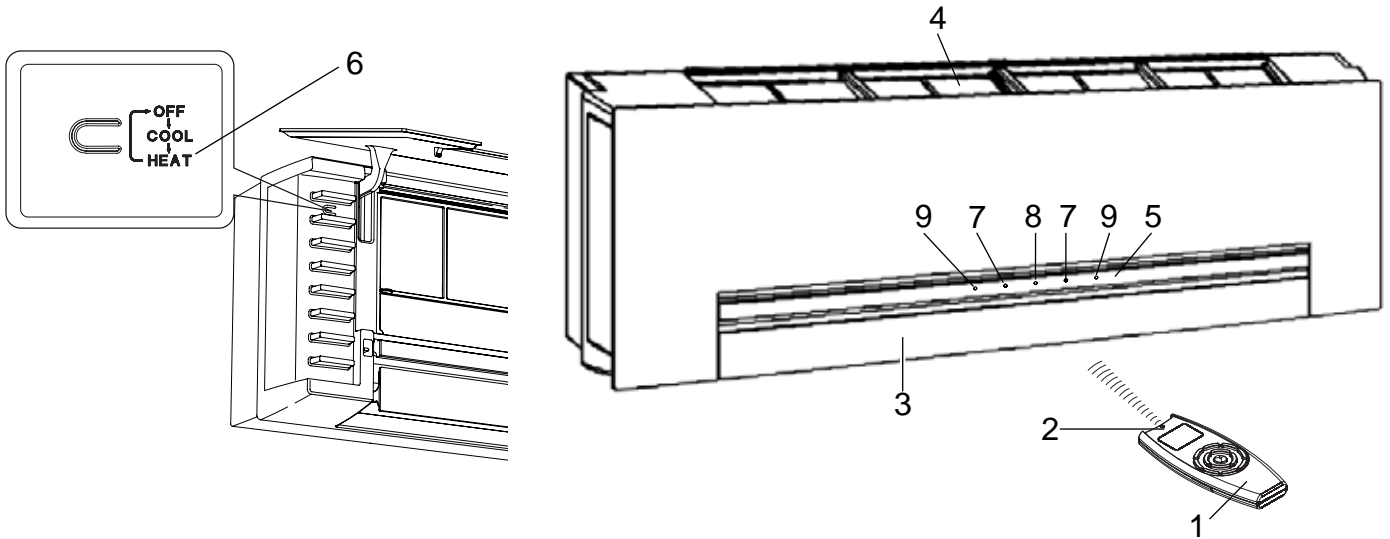

EG

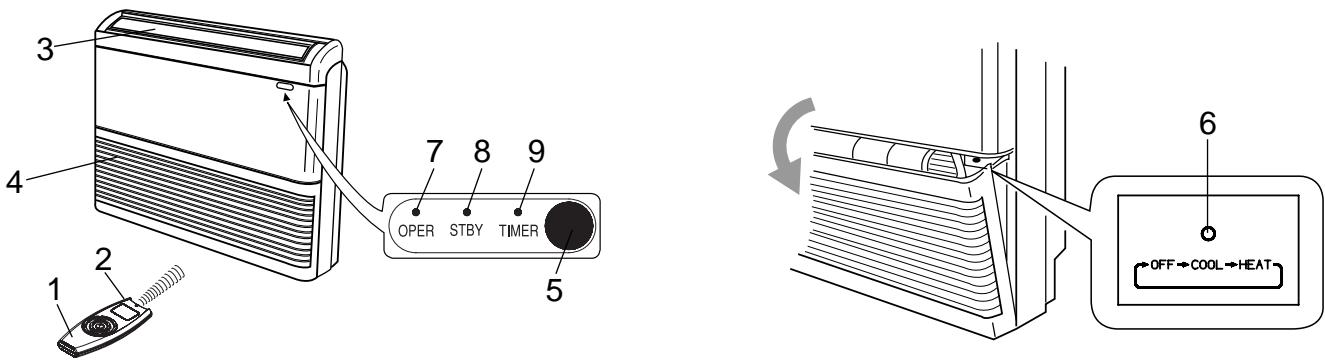

1. Remote control unit.

2. **Remote control sensor:** Detects the room temperature around the remote control unit, the air conditioner is controlled accordingly.

3. **Air outlet:** Conditioned air is blown out of the air conditioner through the air outlet.

4. **Air intake:** Air from the room is drawn into this section and passes through air filter which removes dust.

5. **Remote control receiver:** This section picks up infrared signals from the remote control unit (Transmitter).

6. **Operation selector (without remote control):** Push the button to walk through the operation modes (OFF, COOL and HEAT)



WARNING

The OFF position does not disconnect the power. Use the main power switch to turn off power completely.

7. **OPERATION lamp:** This lamp lights up during operation. It blinks once to announce that the remote control signal has been received and stored.

8. **STANDBY lamp:** This lamp lights up when the air conditioner is connected to the power and ready to receive the remote control command.

9. **TIMER lamp:** This lamp lights up when the system is being controlled by the timer.

NOTES

- It is possible to set the air conditioner in order to let the OPERATION, TIMER and STANDBY lamps always OFF, even during operation.

Press contemporary the IFEEL and FAN buttons on the remote control unit for more than 5 seconds. Repeat the same procedure to set again the normal operation conditions.

- In case of troubleshooting the air conditioner diagnostic system activates the lamps accordingly, even if they are set to OFF. See paragraph TROUBLESHOOTING for further details.

MULTI SPLIT only

- The blinking of TIMER and STANDBY lamps and OPERATION lamp ON, indicates that the operating mode selected is not compatible with the unit. If this happens the air conditioner does not operate until the correct mode is selected.
- AUTOMATIC Mode is not available. If this mode is selected OPERATION lamp is on, STANDBY and TIMER lamps are blinking.

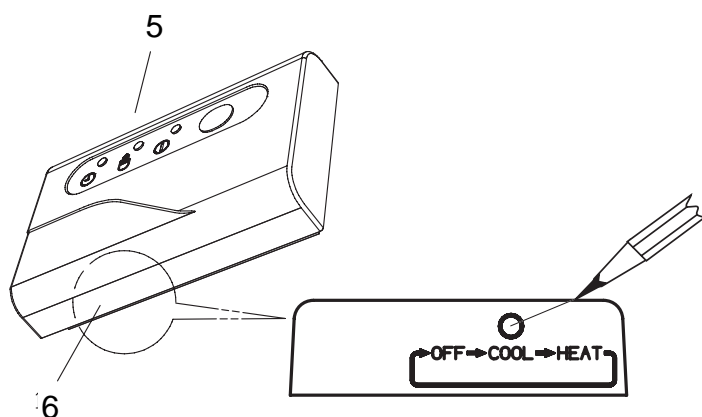
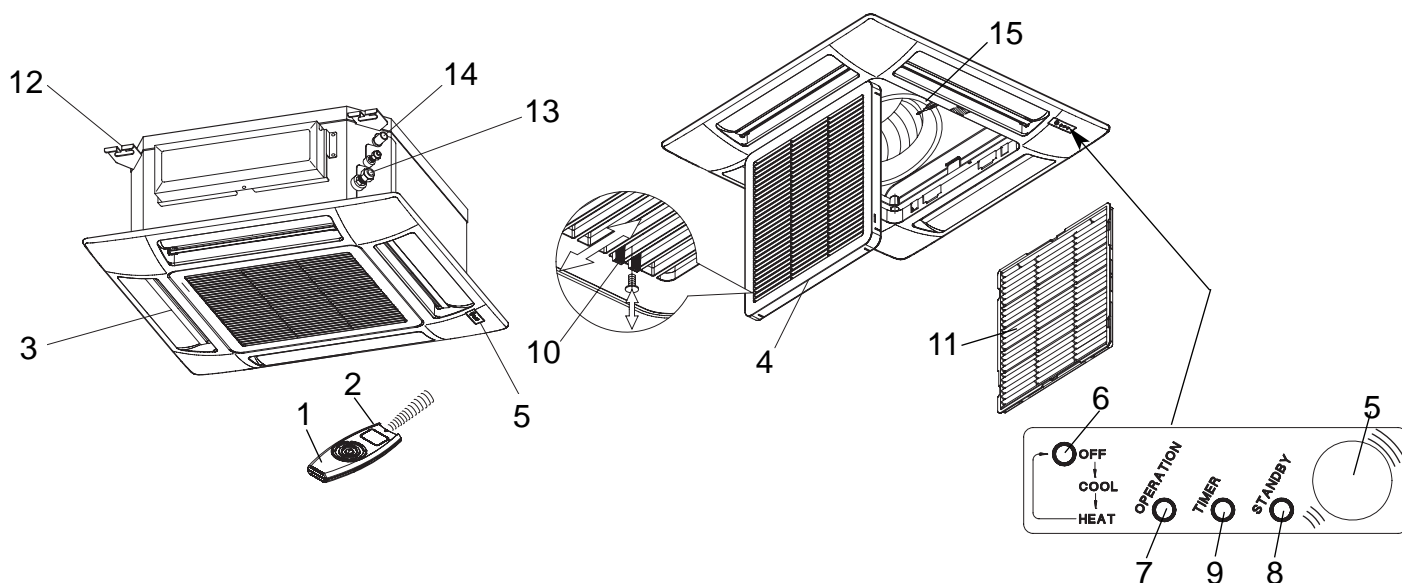

1. Remote control unit.
2. Remote control sensor: Detects the room temperature around the remote control unit, the air conditioner is controlled accordingly.
3. Air outlet: Conditioned air is blown out of the air conditioner through the air outlet.
4. Air intake: Air from the room is drawn into this section and passes through air filter which removes dust.
5. Remote control receiver: This section picks up infrared signals from the remote control unit (Transmitter).
6. Operation selector (without remote control): Push the button to walk through the operation modes (OFF, COOL and HEAT)



WARNING

The OFF position does not disconnect the power. Use the main power switch to turn off power completely.

7. OPERATION lamp: This lamp lights up during operation. It blinks once to announce that the remote control signal has been received and stored.
8. STANDBY lamp: This lamp lights up when the air conditioner is connected to the power and ready to receive the remote control command.
9. TIMER lamp: This lamp lights up when the system is being controlled by the timer.
10. Air intake latch, on two sides.
11. Air filter.
12. Suspension brackets.
13. Refrigerant couplings.
14. Condensate drain connection.
15. Sensor: Detects the room temperature around the unit; when the remote control unit is not active the air conditioner will be set by the detected temperature.

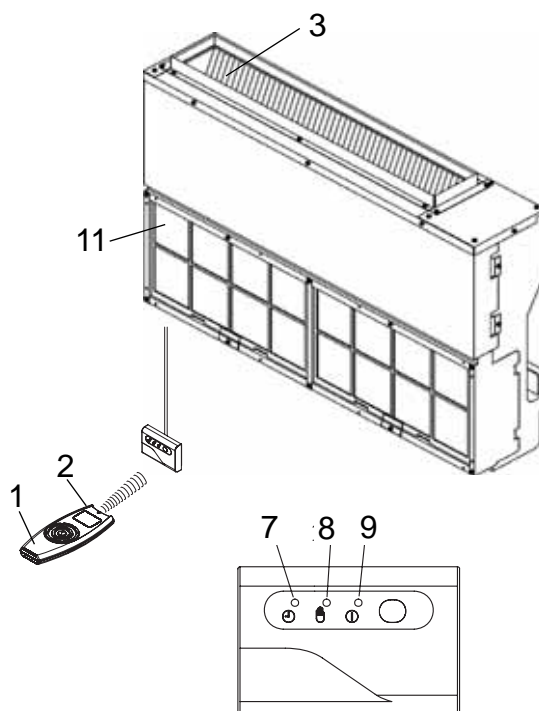

NOTES

- It is possible to set the air conditioner in order to let the OPERATION, TIMER and STANDBY lamps always OFF, even during operation. Press contemporary the IFEEL and FAN buttons on the remote control unit for more then 5 seconds. Repeat the same procedure to set again the normal operation conditions.
- In case of troubleshooting the air conditioner diagnostic system activates the lamps accordingly, even if they are set to OFF. See paragraph TROUBLESHOOTING for further details.

MULTI SPLIT only

- The blinking of TIMER and STANDBY lamps and OPERATION lamp ON, indicates that the operating mode selected is not compatible with the unit. If this happen the air conditioner does not operate until the correct mode is selected.
- AUTOMATIC MODE is not available. If this mode is selected OPERATION lamp is on, STANDBY and TIMER lamps are blinking.

INSTALLATION LOCATION

- We recommend this air conditioner to be installed properly by qualified installation technicians in accordance with the installation instructions provided with the unit.



WARNING

- Do not install this air conditioner where there are fumes or flammable gases, or in an extremely humid space such as a green house.
- Do not install the air conditioner where excessively high heat-generating objects are placed.
- Do not install the air conditioner where the atmosphere is extremely damp or humid (e.g. greenhouse or laundry) it could be wetted by drops of water (i.e. in laundries).
- To protect the air conditioner from heavy corrosion, avoid installing the outdoor unit where salty sea water can splash directly onto it or in sulphurous air near a spa.

ELECTRICAL REQUIREMENTS

- Before installation, check that the voltage of the electric supply in your home or office is the same as the voltage shown on the nameplate.
- All wiring must conform to the local electrical codes. Consult your dealer or a qualified electrician for details.
- Each unit must be properly grounded with a ground (or earth) wire or through the supply wiring.
- Wiring must be done by a qualified electrician.

SAFETY INSTRUCTIONS

- Read this booklet carefully before using this air conditioner. If you still have any difficulties or problems, consult your dealer for help.
- This air conditioner is designed to give you comfortable room conditions. Use this only for its intended purpose as described in this Instruction Manual.



WARNING

- Never use or store gasoline or other flammable vapor or liquid near the air conditioner. It is very dangerous.
- **Never install electrical equipment, which is not protected with IPX1 protection (protection against vertical water drop), under the unit.**
- The manufacturer assumes no responsibilities if the safety regulations or local codes are not observed.



CAUTION

- Never use the power main switch to start or stop the air conditioner: always use the ON/OFF button on the remote control unit or the selector switch on the unit.
- For your safety care check periodically the conditions of the electric supply cable; the electrical connection of the unit is Y type with cable prepared in a special way; in case you should notice any damage due to usage, call the nearest After Sale Service to get the cable replaced.
- Do not let children play with the air conditioner.
- Do not cool the room too much if babies or invalids are present.
- This air conditioner is not intended for use by persons (including children) with reduced physical, sensory or mental capabilities, or lack of experience and knowledge, unless they have been given supervision or instruction concerning use of the air conditioner by a person responsible for their safety.

USING THE REMOTE CONTROL UNIT

HOW TO INSTALL BATTERIES

- Remove the lid in the rear part of the remote control unit and check the settings of the four microswitches as shown below:

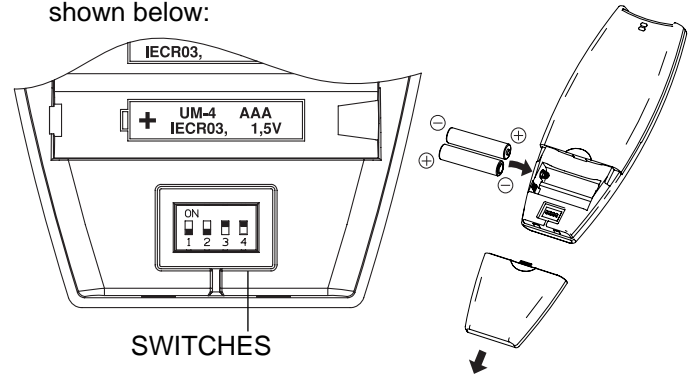

- Insert two AAA alkaline batteries of 1,5 V-DC making sure that point in the direction marked in the battery compartment. The displayed time flashes. Press the SEL TYPE button. Remote controller is now ready for operation.
- The batteries last about six months. Depending on how much you use the remote control unit. Remove the batteries if you do not use the remote control unit for more than one month. Replace the batteries when the remote control unit lamp fails to light, or when the air conditioner does not receive the remote control unit signals.
- The batteries of the remote control contain polluted substances. Exhausted batteries must be disposed according to the laws in force.

NOTE

MULTI SPLIT

Set unit A or B with Remote Control (see procedure in Installation Manual of Outdoor Unit).

TEMPERATURE SENSOR SELECTOR

- Under normal conditions the room temperature is detected and checked by the temperature sensor placed in the remote controller (I FEEL icon displayed). This function is designed to provide a comfortable room temperature by transmitting the temperature control command from the location next to you. Therefore, when using this function, the remote control should always be pointed at the air conditioner.
- It is possible to disable the remote controller room sensor pressing the I FEEL button. In this case the I FEEL icon on the remote controller display lights off and the sensor placed in the air conditioner becomes active.

NOTE

The remote control unit sends the temperature signal at any key pressing and automatically every five minutes. If, due to some troubles, the signal from the remote control is no longer detected, the air conditioner keeps operating using the temperature sensor of the indoor unit to control the room temperature. In this case, the temperature around the remote control unit may differ from the temperature detected in the air conditioner position.

OPERATION WITH THE REMOTE CONTROL UNIT

When using the remote control unit, always point the unit transmitter head directly at the air conditioner receiver.

HOW TO TURN ON THE AIR CONDITIONER

Press the ON/OFF button to turn the air conditioner on. The operation lamp will light up, indicating the unit is in operation.

REMOTE CONTROL UNIT

DISPLAY

Information is displayed when the remote controller is switched on. If switched off, only the operating mode, the room temperature and the clock are shown

I FEEL mode is active (remote controller sensor active)

Operation mode

- Automatic
- Cooling
- Heating
- Dehumidification
- Fan

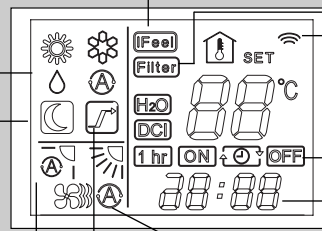

Filter TiO₂ is ON

Displayed when transmitting data

Timer modes

Clock

Room temperature

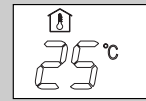

Set point temperature

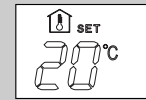

Night mode



Oscillation Flap



HIGH POWER mode

Fan speed

- Automatic
- High speed
- Medium speed
- Low speed

EG

SENSOR

A temperature sensor inside the remote control unit detects the room temperature.

TEMPERATURE SENSOR SELECTOR

Press the I FEEL button to modify the active setting for room temperature detection (from remote controller to air conditioner and viceversa)

TEMPERATURE SETTING BUTTONS

TEMP - (cooler)

Press this button to decrease the set temperature.

TEMP + (warmer)

Press this button to increase the set temperature.

PUSH-BUTTON FLAP

Press this button in order to select the desired function.

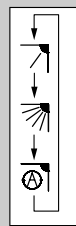

Fixed: six position

Continuous oscillations

Automatically oscillations

TRANSMITTER

When you press the buttons of the remote control unit, the mark appears on the display to transmit the setting changes to the receiver in the air conditioner.

"NIGHT"/"HIGH POWER" BUTTON

Press this button in order to select the desired mode:

NIGHT mode

HIGH POWER mode

FILTER TiO₂ BUTTON (if present)

Press this button in order to select the mode.

"TIMER SEL" BUTTON

Press this button to select the type of timer to activate. For details refer to paragraph "SETTING THE TIMER".

MODE SELECTOR BUTTON

Press this button to modify the air conditioner mode.

(automatic) NOT AVAILABLE FOR MULTISPLIT

When this setting is selected, the air conditioner calculates the difference between the thermostat setting and the room temperature and automatically switches to the "cool" or "heat" mode.

(heating)

The air conditioner makes the room warmer.

(dry)

The air conditioner reduces the humidity in the room.

(cooling)

The air conditioner makes the room cooler.

(fan)

The air conditioner works only as a circulation fan.

ON/OFF BUTTON

This button turns the air conditioner ON and OFF.

"SEL TYPE" BUTTON

Press this button in order to:

- set the clock
- set the ON/OFF timer

For details refer to paragraphs "SETTING THE HOUR" and "SETTING THE TIMER".

"FAN" BUTTON

Fan speed is automatically selected by the microcomputer.

High speed.

Medium speed.

Low speed.

TIMER AND PRESENT TIME SETTING BUTTONS

With these buttons is possible to set the clock and the timer. For details refer to paragraphs "SETTING THE HOUR" and "SETTING THE TIMER".

HOW TO SET THE PRESENT TIME

1. Press the button SEL TYPE three times. The time indication alone flashes.
2. Press the SET H button until the present time hour is displayed. Press the SET M button until the present time minutes are displayed. The display will automatically stop flashing.

COOLING

NOTE

Verify that the unit is connected to the main power and the STANDBY lamp is light up.

1. Set the MODE selector to COOL .
2. Press the ON/OFF button and switch the air conditioner ON.
3. Press the TEMP. buttons to set the desired temperature (the temperature range is between 32 °C max. and 10 °C min.).

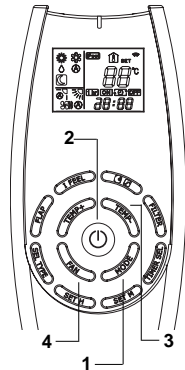

THE DISPLAY SHOWS THE SELECTED TEMPERATURE.



AFTER 5 SECONDS FROM THE REQUIRED TEMPERATURE SETTING THE DISPLAY WILL SHOW THE ROOM TEMPERATURE AGAIN.

4. Press the FAN button to select the fan speed.

HEATING

1. Set the MODE selector to HEAT .
2. Press the ON/OFF button and switch the air conditioner ON.
3. Press the TEMP. buttons to set the desired temperature (the temperature range is between 32 °C max. and 10 °C min.).



THE DISPLAY SHOWS THE SELECTED TEMPERATURE.



AFTER 5 SECONDS FROM THE REQUIRED TEMPERATURE SETTING THE DISPLAY WILL SHOW THE ROOM TEMPERATURE AGAIN.

4. Press the FAN button to select the fan speed.

NOTE

For several minutes after the start of heating operation, the indoor fan will stop until the indoor heat exchanger coil has warmed up sufficiently. This is because the COLD DRAFT PREVENTION SYSTEM is operating. During this period, the STANDBY lamp remains lit.

DEFROSTING OF OUTDOOR UNIT HEAT EXCHANGER

When the outdoor temperature is low, frost or ice may appear on the heat exchanger coil, reducing the heating performance. When this happens, a protection function for the heat exchanger defrosting is activated. During this function operation, the fan of the indoor unit stops and the STANDBY lamp remains lit until defrosting is completed. Heating operation restarts after several minutes. (This interval will vary slightly depending on the room and outdoor temperature).

HEATING PERFORMANCE

A heat pump conditioner heats a room by taking heat from outside air. The heating efficiency will fall off when the outdoor temperature is very low. If enough heat is not obtained with this air conditioner, use another heating appliance in conjunction with it.

AUTOMATIC OPERATION

- NOT AVAILABLE FOR MULTI SPLIT

1. Set the MODE selector to AUTO .
2. Press the ON/OFF button and switch the air conditioner ON.
3. Press the TEMP. buttons to set the desired temperature (the temperature range is between 32 °C max. and 10 °C min.).



THE DISPLAY SHOWS THE SELECTED TEMPERATURE.



AFTER 5 SECONDS FROM THE REQUIRED TEMPERATURE SETTING THE DISPLAY WILL SHOW THE ROOM TEMPERATURE AGAIN.

When this setting is selected, the air conditioner calculates the difference between the thermostat setting and the room temperature and automatically switches to the COOL or HEAT mode as appropriate.

4. Press the FAN selector button to the setting you want.

Example of operation diagram in the  (Auto) mode with the set room temperature at 23°C.

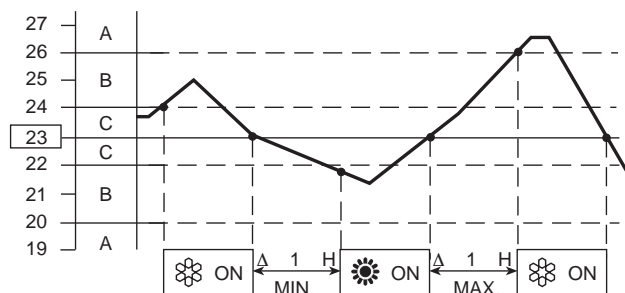

NOTE

The air conditioner changes the operation mode (from cool to heat or vice versa, if one of the following conditions occurs:

- **ZONE A:** changes if the difference between the room temperature and the temperature set on the remote control unit is at least 3°C..
- **ZONE B:** changes if the difference between the room temperature and the temperature set on the remote control unit is at least 1°C, one hour after the compressor stop.
- **ZONE C:** never changes if the difference between the room temperature and the temperature set on the remote control unit is no more than 1°C.

DEHUMIDIFYING (DRY)

1. Set the MODE button to DRY. The icon  is displayed.
2. Press the ON/OFF button and switch the air conditioner ON.
3. Press the TEMP. buttons to set the desired temperature (the temperature range is between 32 °C max. and 10 °C min.).



THE DISPLAY SHOWS THE SELECTED TEMPERATURE.



AFTER 5 SECONDS FROM THE REQUIRED TEMPERATURE SETTING THE DISPLAY WILL SHOW THE ROOM TEMPERATURE AGAIN.

NOTE

- Use DRY operation when you want to reduce the humidity in the room.
- Once the room temperature reaches the set level, the unit repeats the cycle of turning on and off automatically.
- During DRY operation, the fan speed is automatically set (Remote control lamp  is ON) to prevent overcooling.
- Dry operation is not possible if the indoor temperature is 10 °C or less.

EG

FAN ONLY

If you want to make air circulate without any temperature control, follow these steps:

1. Press the ON/OFF operation button and switch the air conditioner ON.
2. Press MODE button until only the  fan sign appears on the display.

ADJUSTING THE FAN SPEED

AUTOMATIC

Simply set the FAN selector to the  position. A microcomputer automatically controls the fan speed when the AUTO mode is selected. When the air conditioner starts operating, the difference between the room temperature and the set temperature is detected by the microcomputer which then automatically switches the fan speed to the most suitable level.



WHEN DIFFERENCE BETWEEN ROOM TEMPERATURE AND SET TEMPERATURE IS		FAN SPEED
Cooling and dehumidifying modes:	2 °C and over	High
	Between 2 and 1 °C	Medium
	Below 1 °C	Low
Heating mode:	2 °C and over	High
	Below 2 °C	Medium

NOTE

The above mentioned data make reference to the conditioner operating when the sensor on the remote control unit is ON. (Refer to temperature sensor selector). If the sensor on the indoor unit is being used then actual operation will slightly differ from that described in the above tables. The automatic speed is not available in FAN ONLY mode.

MANUAL

If you want to manually adjust speed just set the FAN selector as desired.

 High speed  Med. speed  Low speed

FILTER TiO₂ (if present)

Pressing the FILTER button (symbol  on the display) the filtering system with titanium dioxide is activated; this is very effective to prevent bad odours and to eliminate bacteria and micro-organisms.

NOTE

The filter is active only if the internal fan is operating.

NIGHT MODE / ENERGY SAVING

- This mode enables you to save energy.
1. Set the MODE selector to cool, dry or heat.
 2. Press the NIGHT button.
 3. The  mark appears on the display. Press the NIGHT button again to release the NIGHT function.

What does the NIGHT mode mean?

When you select the NIGHT mode, the air conditioner will modify automatically the set temperature after 60 minutes. This enables you to save energy without sacrificing your comfort.

OPERATING MODE	SET TEMPERATURE CHANGE
Heating	Lowered by 1 °C
Cooling and Dehumidifying	Raised by 2 °C

NOTA

During the NIGHT mode the internal fan speed is automatically lower and reduces the noise.

COOLING AND DEHUMIDIFYING

Function selection

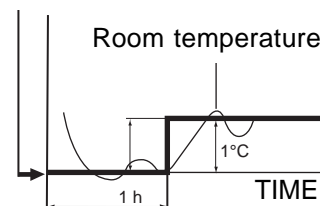

HEATING

Function selection

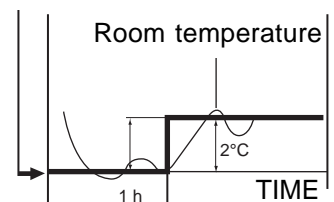

HIGH POWER MODE

When this mode is active the internal fan speed is set automatically and the air conditioner operates, for 15 minutes, at the maximum power. After 15 minutes from the selection the symbol  on the display switch off and the mode is automatically switched off.

NOTE

During the high power operation the room temperature could not correspond to the set temperature.

SETTING THE TIMER

A) HOW TO SET THE ON TIME

1. Press the SEL TYPE button once.
The ON and time indications flash.
2. Press the SET H button until the designed hour is displayed.
Press the SET M button until the designed minutes are displayed. The display will change automatically back to show the present time after 10 sec.
3. Press the ON/OFF button to start the air conditioner.
4. Press the TIMER SEL button to activate the ON timer.

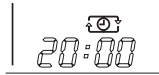
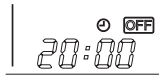
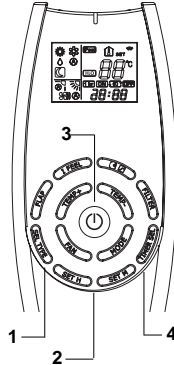
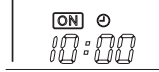

B) HOW TO SET THE OFF TIME

1. Press the SEL TYPE button twice.
The OFF and time indications flash.
2. Press the SET H button until the designed hour is displayed.
Press the SET M button until the designed minutes are displayed. The display will change automatically back to show the present time after 10 sec.
3. Press the ON/OFF button to start the air conditioner.
4. Press the TIMER SEL button two times to activate the OFF timer.

C) HOW TO SET A PROGRAM FOR DAILY ON/OFF OPERATION (OR VICEVERSA)

1. Set the timer ON/OFF as shown in A) and B).
2. Press the ON/OFF button to start the air conditioner.
3. Press three times the TIMER SELECT button to activate the DAILY timer.

NOTE

After timer setting, press PROGRAM button in order to check the ON/OFF setting time.

SETTING THE 1 HOUR TIMER

This function causes the unit to operate for one hour at the set conditions, regardless of whether the unit is on or off.
TIMER SETTING PROCEDURE.

- Press four times the TIMER SEL button. The 1 HOUR TIMER mark will appear on the display.



CANCELLATION PROCEDURE

- Press the ON/OFF button to turn the air conditioner off.
- Wait for the indoor unit to stop operating.
- Press the ON/OFF button again to turn the air conditioner on.

ADJUSTING THE AIR FLOW DIRECTION

HORIZONTAL (manual) Only for AWI-FCI models

The horizontal air flow can be adjusted by moving the vertical vanes to the left or right, as indicated in the following figures.

AWI MODELS

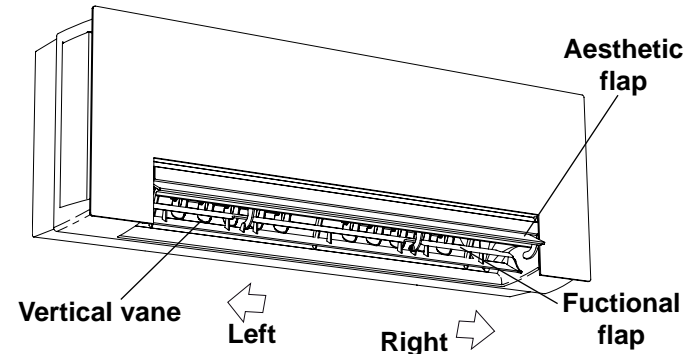

FCI MODELS

VERTICAL VANE

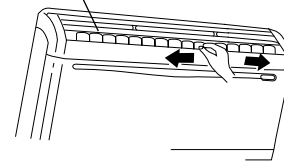

VERTICAL (with remote control unit)

Make sure that the remote control unit has been turned on. Press the FLAP button to select the flap function



Fixed:
six
position

Continous
oscillations

Automatically
oscillations

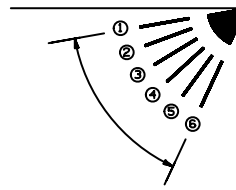

FLAP	MODE

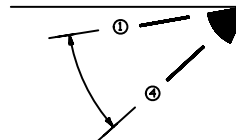

FLAP	MODE

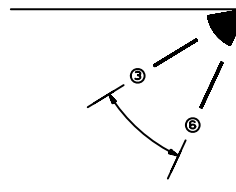

FLAP	MODE

NOTES

- The functional flap automatically closes when the unit is off.
- The aesthetic flap automatically closes 3 minutes after the unit is switched off. (ONLY FOR AWI MODELS)
- When the unit starts in heating operation, the fan speed will be low and the flap will be in the 4 position until the air being blown out of the unit begins to warm. Once the air warms up, the flap position and fan speed change to the settings specified with the remote control.

EG



CAUTION

Do not move the flap with your hands when the air conditioner is running.



CAUTION

- Use the **FLAP** button on the remote control to adjust the position of the flap. If you move the flap by hand, the factual flap position and the flap position on the remote control may no longer match. If this should happen, shut off the unit, wait for the flap to close, and then turn on the unit again; the flap position will now be normal again.
- Do not have the flap pointed down during cooling operation. Condensation may begin to form around the air vent and drip down.

AWI MODELS

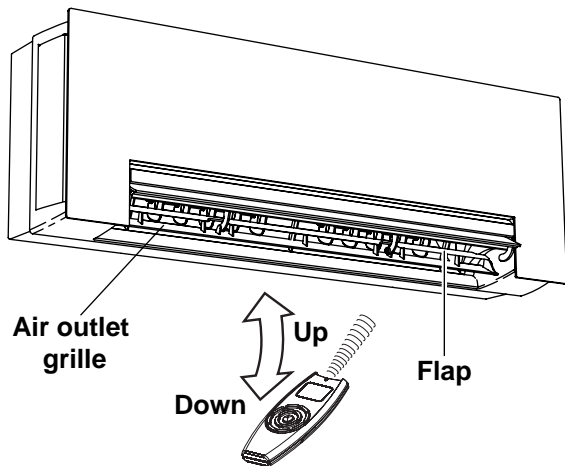

FCI MODELS

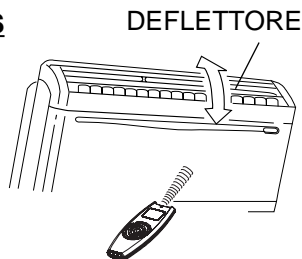

ASI MODELS

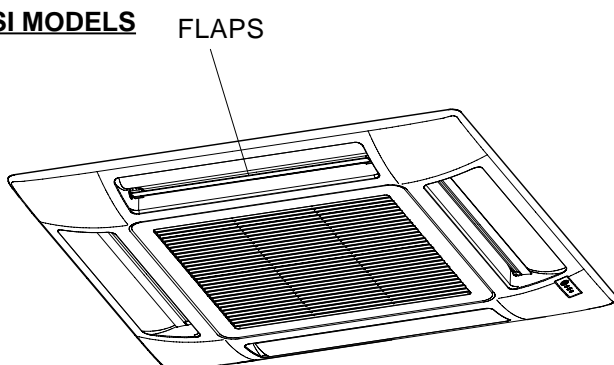

HOW TO ADJUST THE FLAP DIRECTION

AWI MODELS

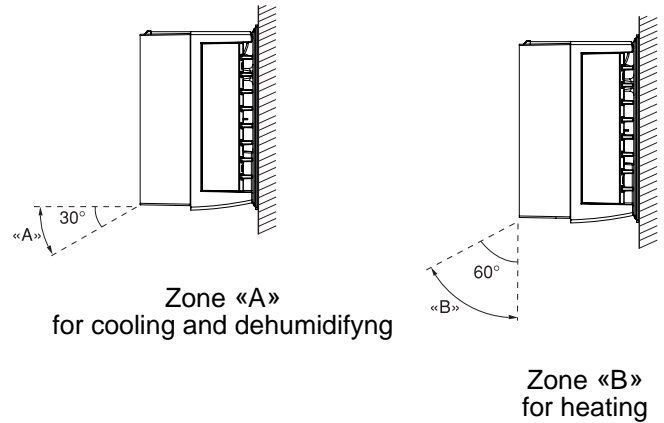

FCI MODELS

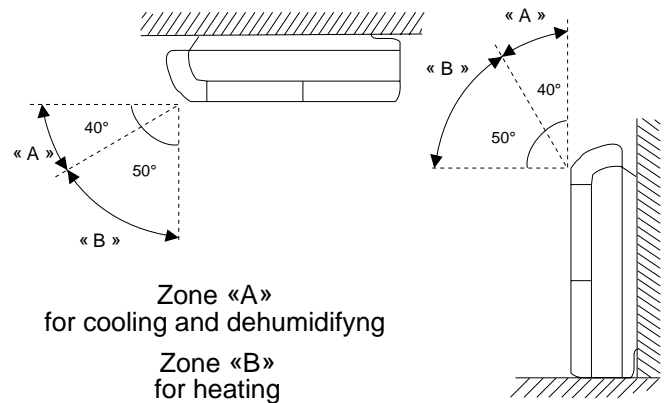

CAUTION

(ONLY AWI- FCI MODELS)

Set vertical vanes to the front position during **COOLING/DRY** operation if humidity is high. If the vertical vanes are set to the left-most or right-most position, condensation will form around the air outlet and drip off.

ASI MODELS

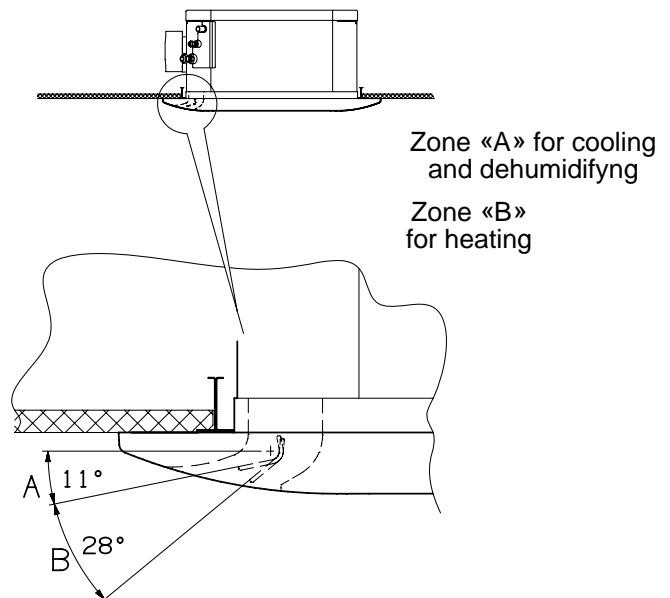

OPERATION WITHOUT THE REMOTE CONTROL UNIT

If you have lost the remote control unit or it has troubles, follow the steps below.

1. WHEN THE AIR CONDITIONER IS STOPPED

If you want to turn on the air conditioner push the operation selector with a pen to select the desired mode (COOL or HEAT).

NOTE

The air conditioner will start in **HIGH fan speed**. The temperature setting is **25°C for cooling mode and 21°C for heating mode**.

2. WHEN THE AIR CONDITIONER IS RUNNING

If you want to turn off the air conditioner push the operation selector with a pen until the OPERATION lamp is turned off.

NOTE

Power failure during operation.

In the event of power failure, the unit will stop. When the power is resumed, the unit will restart automatically after 3 minutes.

AWI MODELS

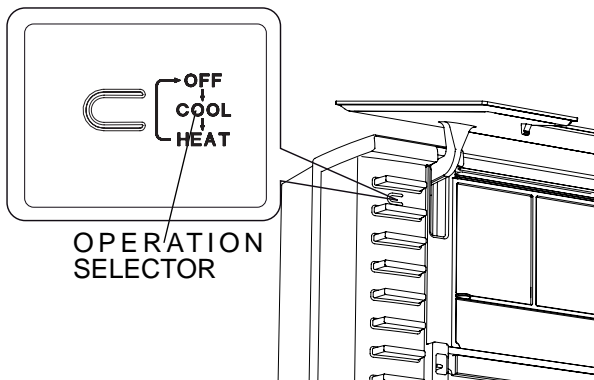

FCI MODELS

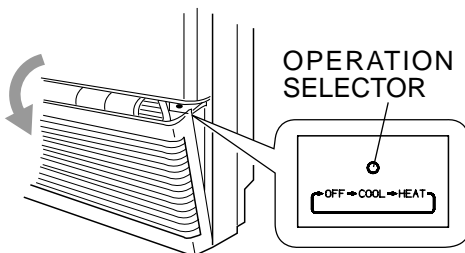

ASI MODELS

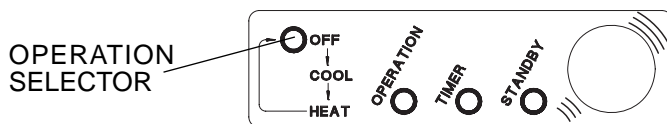

SDI MODELS

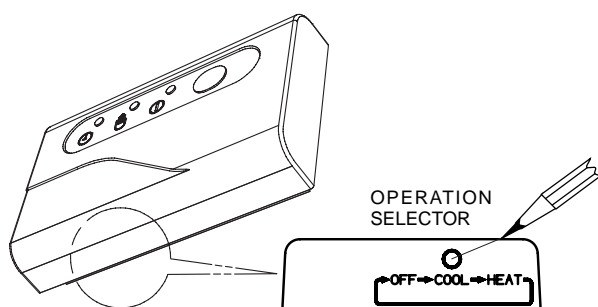

CARE AND CLEANING



WARNING

- Maintenance operations must be carried out by specially trained personnel.
- For safety, be sure to turn the air conditioner off and also to disconnect the power before cleaning.
- Do not pour water on the indoor unit to clean it. This will damage the internal components and cause an electric shock hazard.

CASING AND GRILLE (INDOOR UNIT)

Clean the casing and grille of the indoor unit with a vacuum cleaner brush, or wipe them with a clean, soft cloth.

If these parts are stained, use a clean cloth moistened with a mild liquid detergent.

When cleaning the grille, be careful not to force the vanes out of place.



CAUTION

- Never use solvents, or harsh chemicals when cleaning the indoor unit. Do not wipe the plastic casing using very hot water.
- Some metal edges and the vanes are sharp and may cause injury if handled improperly; be especially careful when you clean these parts.
- The internal coil and other components of the outdoor unit must be cleaned every year. Consult your dealer or service centre.

HOW TO REMOVE THE FRONT PANEL (ONLY FOR AWI-ASI MODELS)

The front panel can be removed in order to wash it with water.

AWI MODELS

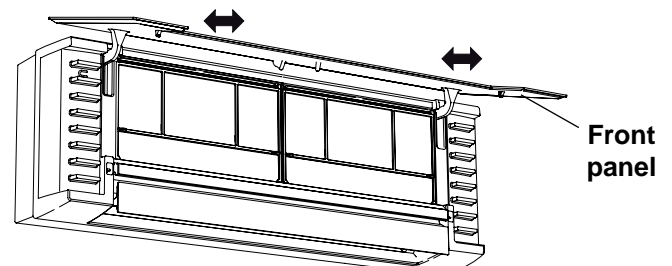

- With the front panel open all the way, grip both arms with your hands and pull toward you to remove.
- To remount, hold the front panel roughly horizontal and push it in until the arm shafts fit into the indentations in the main unit, then fit the front panel into place.

ASI MODELS

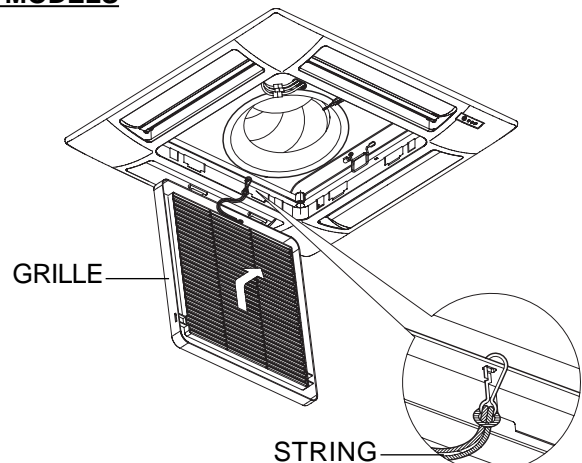

- Detach the safety string from the frame (remember to attach it again after cleaning or maintenance).
- Open the air intake grille, hold it on and pull it toward you to detach the two guides.

Washing the grille with water

- Clean the grille gently using a soft sponge, or the like. Then wipe away any remaining moisture.
- Neutral detergent may be used to remove stubborn dirt. Then rinse thoroughly with water and wipe away any remaining moisture.

ADDITIONAL MAINTENANCE (ONLY FOR ASI MODELS)

The inspection or replacement of internal components involve the removal of the condensate drain pan.

EG



CAUTION

Some metal edges and the vanes of heat exchanger are sharp and may cause injury if handled improperly; be especially careful when you clean these parts.

HOW TO REMOVE THE CONDENSATE DRAIN PAN

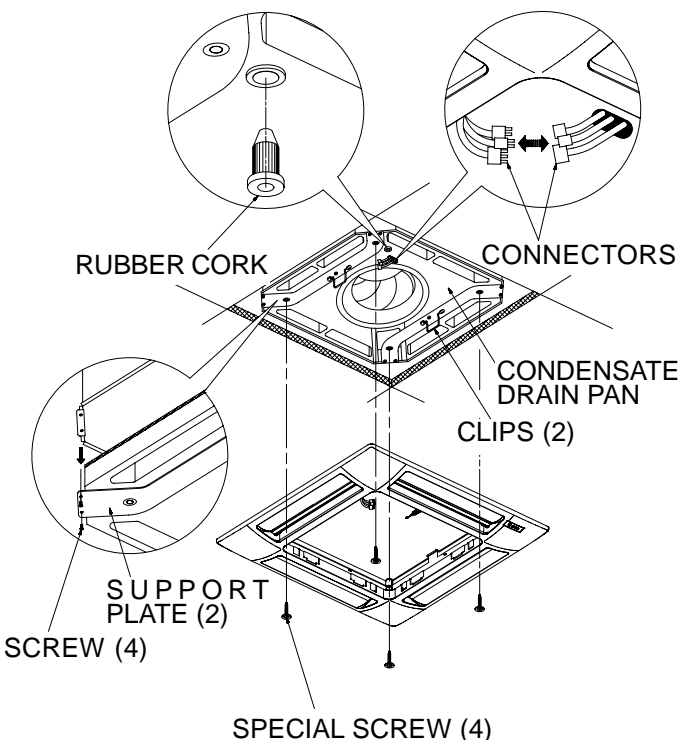

1. Open the air intake grille.
2. Drain the condensate water into a bucket through the rubber cork that should be soon closed.
3. Remove the frame-grille assembly by loosening the four special screws with washer; you can utilise the two clips that fix the frame to the unit.
4. Disconnect the electrical connectors between the frame-grille assembly and the unit.
5. Remove the four screws of the two support plates.
6. Grasp the two support plates, remove with care the condensate drain pan and clean it inside, if necessary.
7. Once finished the maintenance, reassemble the pan, aligning the side with the hole for condensate drain and the side with the pump; insert the connectors of the unit into the proper hole in the pan.
8. Fix again the four screws of the support plates and the frame group aligning the corner from which the wires exit and the corner with the connectors of the unit.
9. Mount the air intake grille along with the filter; be sure that the safety string has been attached and that the latch screw has been fixed on both sides.

AIR FILTER

AWI-FCI MODELS

The filter behind the front panel should be checked and cleaned at least once every two weeks.

HOW TO REMOVE THE FILTER

AWI MODELS

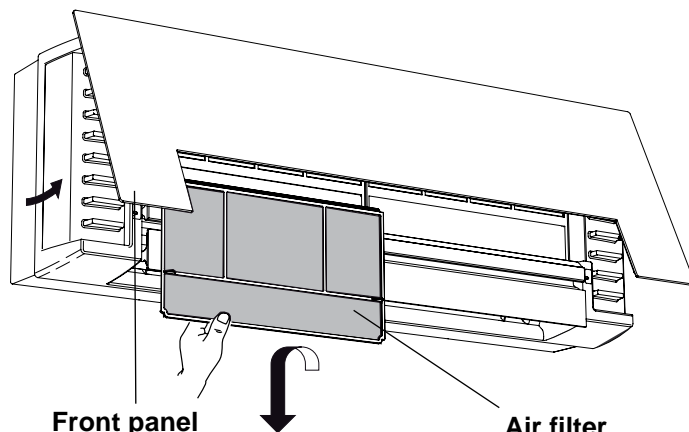

1. Grasp both ends of the front panel and pull it towards you and up.
2. Push the filter up slightly, and then take it out. Clean the air filter and replace it.

FCI MODELS

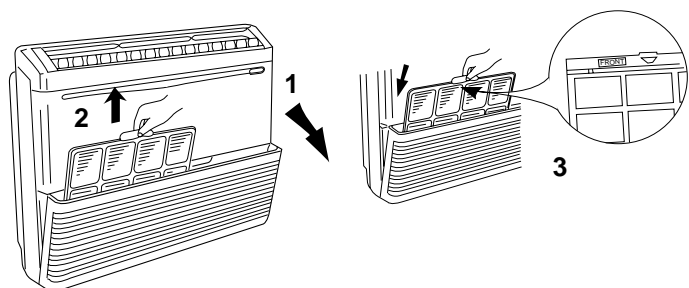

1. Grasp both ends of the air intake grille and pull to open it.
2. Hold the air filter by the tab and pull it upward. Clean the air filter.
3. When replacing the filter, make sure that the FRONT mark is facing you. Reinsert the filter into place and close the air intake grille.

ASI-SDI MODELS

The air filter should be cleaned at least once every six months or more frequently; it depends on the real operation conditions.

HOW TO REMOVE THE FILTER

ASI MODELS

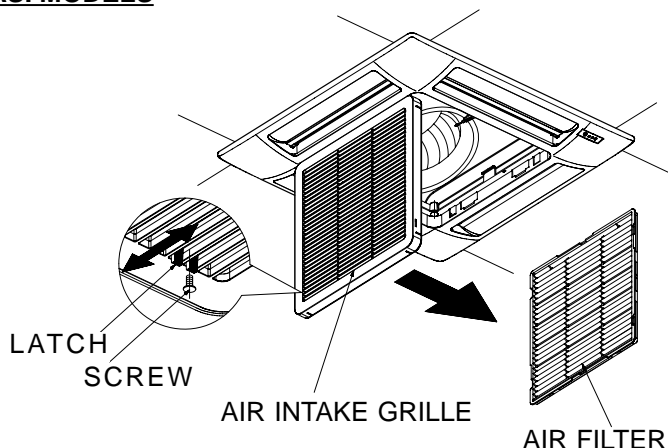

1. Remove the screw on each side out of the latch using a screwdriver.
2. Press on the two latches of the air intake grille with your thumbs in the direction of the arrow to open the grille.
3. Open the air intake grille downward.
4. Remove the air filter from the air intake grille. Clean the air filter.
5. Insert the filter correctly again inside the grille, close the grille letting the latches slide toward the outside and fix again the latch with the screw on both sides.

SDI MODELS

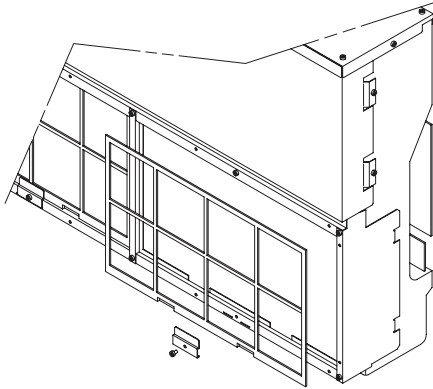

1. Remove the screw.
2. Remove the filter and clean it.
3. Insert the filter again and fix the screw.

FILTER CLEANING

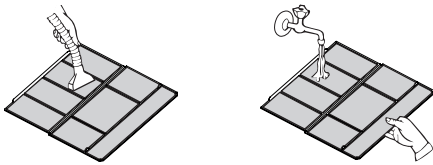

Use a vacuum cleaner to remove light dust. If there is sticky dust on the filter, wash the filter in lukewarm, soapy water, rinse it in clean water, and dry it.

ACTIVATED CARBON AIR FILTER (ACCESSORY SUPPLIED ON REQUEST - ONLY FOR FCI MODELS)

The activated carbon air filter is to be added to the standard filter.

It is made of two layers:

- the first layer consists in a synthetic honey comb high efficiency media to remove the dust and purifying the air.
- the second layer in charcoal media deodorizing the ambient air.

NOTE

1. Two activated carbon air filters for one indoor unit are in this polyethylene bag.
2. Open the bag just before installing the activated carbon air filters, if not the deodorizing effect durability of the filter may be decreased.



WARNING

This activated carbon air filter cannot remove harmful gases or vapors nor ventilate air in the room. You must open doors or windows frequently when you use gas or oil heating appliances. Otherwise there is a risk of suffocation in an extreme case.

REPLACEMENT OF ACTIVATED CARBON AIR FILTER

- The filter is disposable.
- Do not throw away the filter frame.
- The used filter cannot be reused even after cleaning up.
- Obtain the filters for replacement at your nearest dealer.
- Check the state of dirtiness at least once every two weeks.
- Replace the filter after six months' operation.

ACTIVATED CARBON AIR FILTER INSTALLATION PROCEDURE

1. Open the unit intake air grille and pull out the standard air filter.
2. Apply on the rear side of the filter the two springs supplied with the accessory.
3. Fix the activated carbon filter by the springs.
4. Insert the two air filters one over the other and close the intake grille.

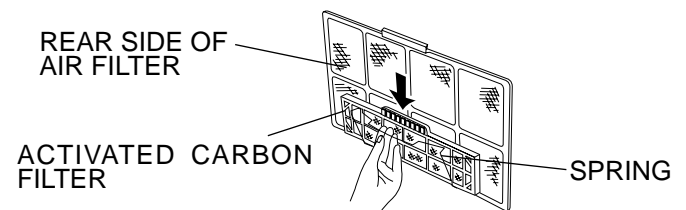

TIPS FOR ENERGY SAVING

DO NOT:

- Block the air intake and outlet of the unit. If they are obstructed, the unit will not work well, and may be damaged.
- Let direct sunlight into the room. Use sunshades, blind or curtain.

DO:

- Always try to keep the air filter clean. A clogged filter will impair the performance of the unit.
- To prevent conditioned air from escaping, keep windows, doors and any other openings closed.

TROUBLESHOOTING



WARNING

- The use of portable telephones near the air conditioner may cause disturbance to its normal operation and must be avoided. In case abnormal operation is noticed, (OPERATION lamp lights, but the air conditioner will not run) to restore normal operation turn-off electric supply for about 3 minutes, by disconnecting the main switch or the wall plug, then start again the air conditioner.

If your air conditioner does not work properly, first check the following points before requesting service.
If it still does not work properly, contact your dealer or service centre.

Trouble: the air conditioner does not run at all.

Possible cause:

- Power failure.
- Leakage breaker tripped.
- Operation button is OFF.
- Batteries in remote control unit have run down.

Remedy:

- Restore power.
- Contact service centre.
- Press the button again.
- Replace batteries.

Trouble: Poor cooling or heating performance.

Possible cause:

- Dirty or clogged air filters.
- Heat source or many people in room.
- Doors and/or windows are open.
- Obstacle near air intake or air discharge port.
- The set temperature on the remote control unit is too high.
- Outdoor temperature is too low (heat pump version).
- Defrosting system does not work (heat pump version).

Remedy:

- Clean air filters to improve airflow.
- Eliminate heat source if possible.
- Shut them to keep the heat or cold out.
- Remove it to ensure good airflow.
- Set the right temperature on the remote control unit.
- Try to use a back-up heater.
- Consult your dealer.

Trouble: Clicking sound is heard from the air conditioner.

Possible cause:

- During operation, any plastic parts may expand or shrink due to a sudden temperature change. In this event, a clicking sound may occur.

Remedy:

- This is normal, and the sound will disappear when an even temperature is settled.

AUTO-DIAGNOSIS

LEDS			POSSIBLE CAUSE	REMEDY
STANDBY	OPERATION	TIMER		
F	F	O	Defective indoor unit room sensor	Contact service centre
O	F	F	Defective Indoor unit coil sensor	Contact service centre
F	F	F	Communication trouble between indoor and outdoor unit Unit A or B has not been set for Multisplit System (see Installation Instruction)	Contact service centre Set unit A or B with Remote control
F	O	O	Outdoor unit trouble	Contact service centre
F	●	F	Automatic operation mode has been selected or the operating mode selected is not compatible with the unit for Multisplit System	Change mode
O	F	O	Malfunctioning of the condensate drainage system	Contact service centre

O = LED OFF

● = LED ON

F = Flashing LED

EG HOW TO REMOVE BATTERIES

- Remove the lid.
- Press the battery toward the negative end and lift it out by its positive end (as shown in the figure).
- Remove the other battery in the same way.

I COME RIMUOVERE LE BATTERIE

- Rimuovere il coperchio.
- Premere la batteria verso il polo negativo ed estrarla dalla parte del polo positivo (come mostrato in figura).
- Rimuovere l'altra batteria allo stesso modo.

F COMMENT ENLEVER LES PILES

- Enlever le couvercle.
- Pousser la pile vers le pôle négatif et enlever le pôle positif (comme représenté dans la figure).
- Enlever l'autre pile de la même manière.

D WIE DIE BATTERIEN ZU ENTFERNEN

- Die Abdeckung entfernen.
- Drücken Sie die Batterie nach dem negativen Pol und entfernen Sie sie vom positiven Pol (wie in Abbildung gezeigt ist).
- Entfernen Sie ebenso die andere Batterie.

E COMO REMOVER LAS PILAS

- Remover la tapa.
- Apretar la pila hacia el polo negativo y remover el polo positivo (como en figura).
- Remover así también la otra pila.

P COMO REMOVER AS PILHAS

- Remover a tampa.
- Premir a pilha para o polo negativo e remover a parte do polo positivo (como indicado na figura).
- Remover a outra pilha ao mesmo modo.

GR ΠΩΣ ΝΑ ΑΦΑΙΡΕΣΤΕ ΤΙΣ ΜΠΑΤΑΡΙΕΣ

- Πιέστε την μπαταρία προς τον αρνητικό πόλο και αφαιρέστε την από τη μεριά του θετικού πόλου (όπως φαίνεται στην εικόνα).
- Αφαιρέστε την άλλη μπαταρία με τον ίδιο τρόπο.

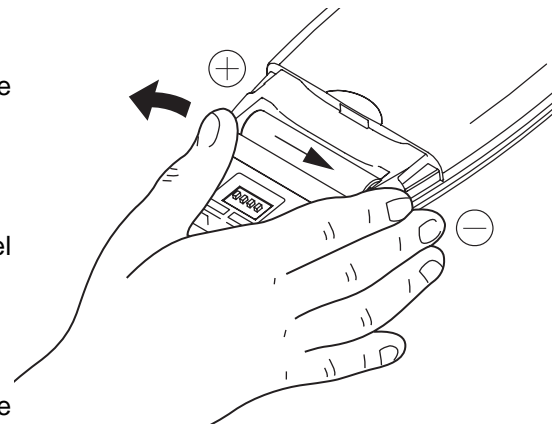

F-GAS Regulation (EC) No. 842/2006

- EG** Do not vent R410A into atmosphere: R410A is a fluorinated greenhouse gas, covered by Kyoto Protocol, with a Global Warming Potential (GWP) = 1975.
- I** Non disperdere R410A nell'atmosfera: R410A è un gas fluorinato a effetto serra, coperto dal protocollo di Kyoto, con potenziale di riscaldamento globale (GWP) = 1975.
- F** Ne déchargez pas R410A dans l'atmosphère : R410A est un gaz fluoré à effet de serre, couvert par le protocole de Kyoto, avec un potentiel de chauffage global (GWP) = 1975.
- D** Zerstreuen Sie R410A in Atmosphäre nicht: R410A ist ein fluoriertes Gas, abgedeckt durch Kyoto Protokoll, mit einem globalen wärmenden Potential (GWP) = 1975.
- E** No expulsar R410A a la atmósfera: el R410A es un gas fluorado de efecto invernadero, cubierto por el protocolo de Kyoto, con potencial de calentamiento global (GWP) = 1975.
- P** Não exale R410A na atmosfera: R410A é um fluorinated gás, coberto pelo protocolo de Kyoto, com um global Potencial Aquecendo-se (GWP) = 1975.
- GR** Μην αερίστε R410A στην ατμόσφαιρα: R410A είναι ένα φθοριωμένο θερμοκήπιο αέριο, που καλύπτεται από το πρωτόκολλο του Κιότο, με έναν σφαιρικό Δυνατότητα θέρμανσης (GWP) = 1975.

In order to carry on a constant improvement, our products can be modified without prior notice.
Per garantire un costante miglioramento dei nostri prodotti, ci riserviamo di modificarli senza preavviso.
Par souci d'amélioration constante, nos produits peuvent être modifiés sans préavis.
Unsere Produkte werden laufend verbessert und können Vorankündigung abgeändert Werden.
En el interés de mejoras constantes, nuestros productos pueden modificarse sin aviso previo.