

Service Manual for the Envision EN9410

Feb, 18th, 2005 Revision: 1A

Issued By:

Checked By:

The release of this document is under control by the company. Any extra copy of this document must be written permission by the product manager.

- Quanta Confidential -

History Page

Reversion	Date	Remark
1A	2/18/2005	1 ST Released.

Content

Chapter	Page
A. WARNING	4
B. SAFETY PRECAUTIONS	5
1. DIMENSIONS	6
2. GENERAL INFORMATION	8
3. SPECIFICATIONS	9
4. THEORY OF OPERATION	20
5. CONTROL LOCATION	23
6. NECESSARY EQUIPMENT LIST	32
7. BLOCK DIAGRAM	33
8. CONDUCTOR VIEW	35
9. SCHEMATIC DIAGRAM	38
10. EXPLODED VIEW	45
11. TROUBLE SHOOTING HINTS	46
12. REPLACEMENT PARTS LIST	48
13. AUTO BALANCE	48

WARNING

This service information is designed for experienced repair technicians only and is not designed for use by the general public

It does not contain warnings or cautions to advise non-technical individuals of potential dangers in attempting to service a product.

Products powered by electricity should be serviced or repaired only by experienced professional technicians.

Any attempt to service or repair the product or products dealt within this service information by anyone else could result in serious injury or death.

SAFETY PRECAUTIONS

1. CAUTION:

No modification of any circuit should be attempted. Service work should only be performed after you are thorough familiar with all of the following safety checks and servicing guide lines.

2. SAFETY CHECK

Care should be taken while servicing this LCD display. Because the high voltage is used in the inverter circuit. These voltages are exposed in such areas as the associated transformer circuits.

3. POWER SUPPLY REQUIREMENTS

The external power converter for this display utilizes AC and DC cords. AC cord is detachable, But DC cord is permanently attached. Any attempt to replace another adapter could result in serious problem on the display.

4. LEAKAGE CURRENT HOT CHECK

4-1 Plug the AC cord directly into the AC outlet. Do not use an isolation transformer during this check.

4-2 Connect a 1500 ohm, 10 watt resistor, paralleled by a 0.15uF capacitor between each metallic part and a good earth ground.

4-3 Use an AC voltmeter with 1000 ohm / volt or more sensitivity and measure the AC voltage across the combination 1500 ohm resistor and 0.15uF capacitor.

4-4 Move the resistor connection to each exposed metallic part and measure the voltage.

4-5 Reverse the polarity of the AC plug in the AC outlet and repeat the above measurement.

4-6 Voltage measured must not exceed 1.5 volt RMS, from any exposed metallic part to the ground. A leakage current tester may be used in the above hot check, in which case any circuit measured must not exceed 1 milliamp. In the case of a measurement exceeding the 1 milliamp value, a rework is required to eliminate the chance of a shock hazard.

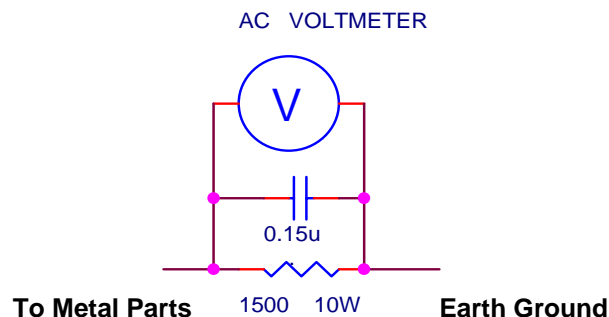

1. DIMENSIONS (Unit:mm)

1.1 Front View (ID1)

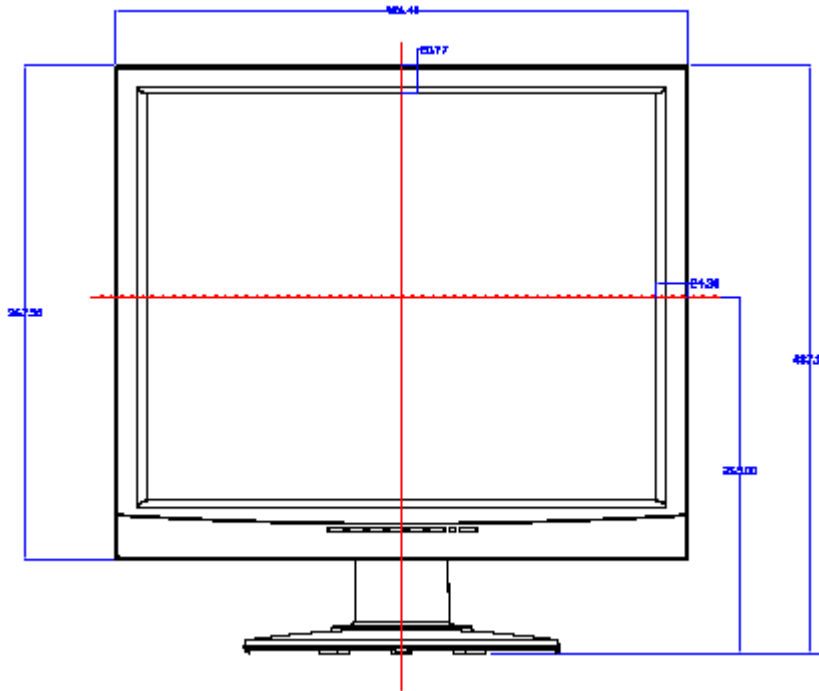

1.2 Top View

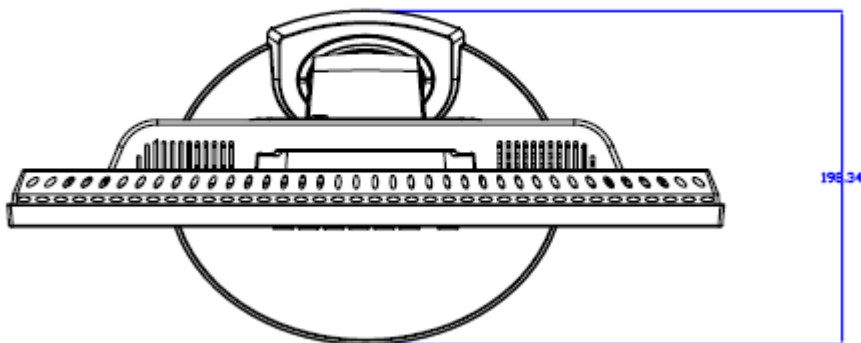

1.3 Rear View

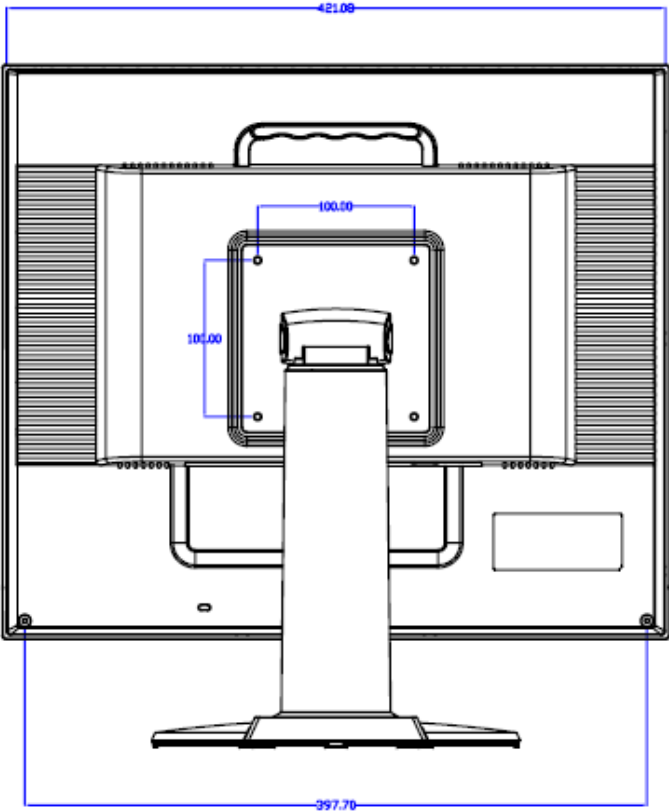

1.4 Side View

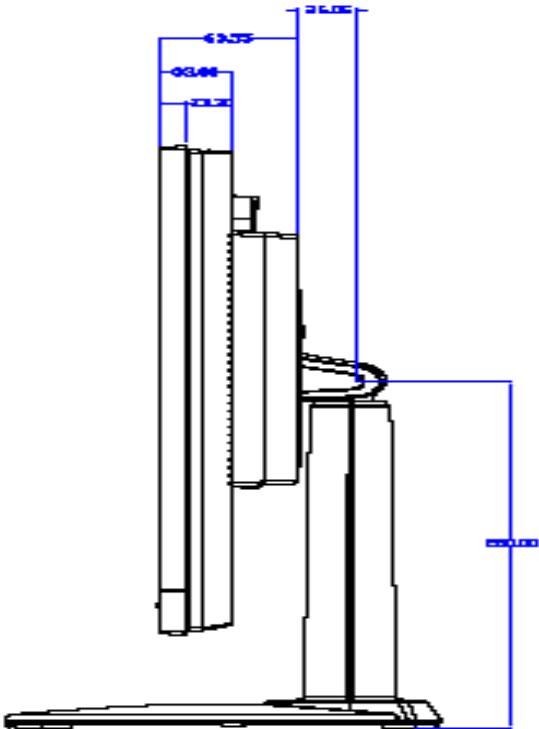

2. GENERAL INFORMATION

2.1. OUTLINE

This monitor is 19" multi-scan color LCD display with the following features OSD (on screen display) control allows easy user adjustment . Power saving function, which helps saving energy, is also one of the highlights of this model.

2.2. FEATURES

2.2.1 Power Saving

Built in Power Saving function based on VESA-DMPS standard. Power energy shall be saved by controlling the circuit in accordance with power save signal from computer.

2.2.2 OSD (on screen display) function

OSD (3 Languages) function is excellent and new man-machine interface.

Anyone is able to set up the picture as the like through OSD menu.

2.2.3 Self Test function

Self Testing picture comes out by pushing any key in the case of no-connection with computer or power saving operation. This function shows if monitor is alive or not and can be used for self aging test.

2.2.4 Ergonomic design

Low emission design to meet MPR II and TCO

2.2.5 Multi scan with digital technology

8 bit micro controller controls the circuit operation to meet with wide range signal of Fh=31~83 kHz and Fv= 56~75 Hz. So VGA720x400, VGA640x480, SVGA800x600,XGA 1024x768, SXGA 1280x1024 .

2.2.6 Factory preset

The product has 32 memory mode in total ,15 modes are preset and 17 modes are user definable.

2.2.7 Fine dot pitch

LCD panel with a fine dot pitch (Horizontal: 0.294 mm / Vertical: 0.294mm)

2.2.8 Superior display performance

High contrast: 500: 1(Typical)

High brightness: 250 cd / m2 (Typical)

Wide view angle: 140/ 130degrees (H/V)

2.2.9 Special function

VESA DDC2B (Display Data Channel) Compatible

3. SPECIFICATION

3.1. Outline

3.1.1 Front Indication: POWER SW, LED (Green/Amber), UP, Down, LEFT, RIGHT, Set/Auto and MENU key are located on the front panel.

3.1.2 Video signal cable connector, and DC inlet are located on the backside cabinet.

3.1.3 OSD menu includes the following function. CONTRAST, BRIGHTNESS, H.POSITION, V.POSITION
COLOR-TEMPERATURE, CLOCK, PHASE, LANGUAGE, VOLUME, POWER-ON-RECALL

3.1.4 CONTRAST and BRIGHTNESS can be directly controlled with UP / Down key.

3.1.5 VOLUME can be controlled with LEFT / RIGHT key.

3.2. MECHANICAL SPECIFICATIONS

3.2.1 Dimension Height: 437mm
 Width: 426mm
 Depth: 198mm

3.2.2 Net Weight: 5.0 kg

3.2.3 Maximum Viewable Area: Diagonal 482.6mm(19")

3.3. PANEL SPECIFICATIONS

Part No.	CLAA190EA03
Driver bit of panel	8bit + dithering
Contrast ratio	500:1
Brightness	250 cd/ m2
Pixel pitch	0.294 mm
Response time	Typical 16 ms
View angle	70/70/70/60degree
Color coordinate	x=0.313,y=0.329

3.4. CONNECTORS

3.4.1 AC inlet : CEE22 typed connector

3.4.2 Attached video signal cable connector x 1

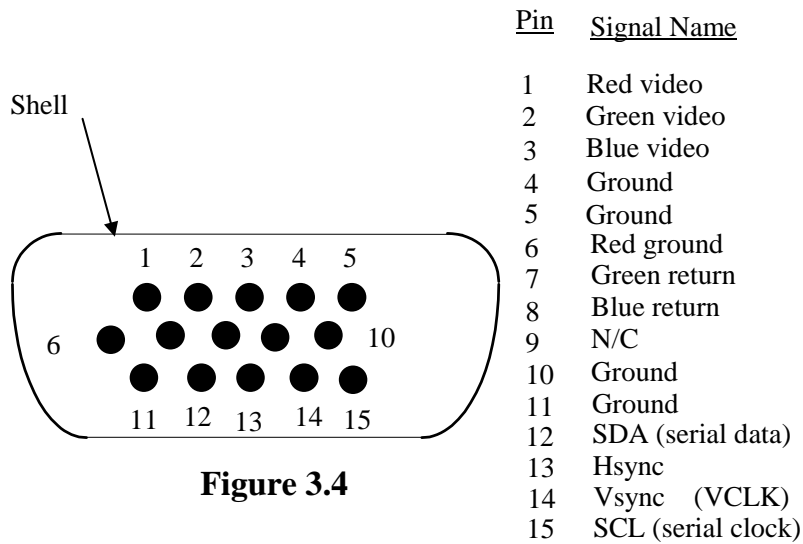

Figure 3.4

Signal cable input connector.

3.5. ELECTRICAL SPECIFICATIONS

3.5.1 Standard conditions

Display area (HxV)	378.3*303mm
Video signal level	0.7 Vpp
Contrast	Max.
Brightness	Max.
Ambient Temperature	25 +/- 5 C degrees
Input voltage	Universal power
Warming up time	At least 30
Display mode	1280 x 1024

3.5.2 POWER

3.5.2.1 Power supply

AC-DC adapter

Input voltage	100-240V
Input current	Max. 0.8Arms
Frequency range	47 - 63 Hz
Inrush current	Shall be less than the ratings of critical components (Including fuse, rectifiers and surge limiting device) for all conditions of line in voltage.

Maximum power consumption: 50 Watts

3.5.2.2 Power Management

MODE	H-SYNC	V-SYNC	COLOR OF POWER LED	POWER CONSUMPTION	RECOVERY TIME
On	Active	Active	Green	< 50 Watts	-
Off	Inactive	Inactive	Amber	< 1 Watts	< 5 seconds

At first power on w/o signal LED will be green blinking + message on screen.

3.5.3 Signal level and input impedance

3.5.3.1 Video Signal level

This LCD display is adjusted at the factory using 0,7 Vp-p Video signal.

3.5.3.2 Sync Signal level

H/V Separate: TTL level

3.5.3.3 Input impedance

Video input: 75 ohms +/- 1%

Sync input: > 1 k ohms

3.5.4 Display Area

Display area: 378.3*303mm

3.5.5 Preset Timings

The product has 32 memory modes in total. 15 modes are preset and 17 modes are user definable.

	1	2	3	4	5
Format	640x350@70Hz	720x400@70Hz	640X480@60Hz	640x480@72Hz	640x480@75Hz
Pixel Clock(MHz)	25.176	28.320	25.175	31.500	31.500
Horizontal					
Sync Polarity	P	N	N	N	N
Frequency(KHz)	31.470	31.467	31.469	37.861	37.500
Total Time(pixels)	800	900	800	832	840
Display Time(pixels)	640	720	640	640	640
Sync Width(pixels)	96	108	96	40	64
Back Porch(pixels)	48	54	40	120	120
Front Porch(pixels)	16	18	8	16	16
Blank time(pixels)	160	180	144	176	200
Vertical					
Sync Polarity	N	P	N	N	N
Frequency(Hz)	70.089	70.082	59.940	72.809	75.00
Total Time(lines)	449	449	525	520	500
Display Time(lines)	350	400	480	480	480
Sync Width(lines)	2	2	2	3	3
Back Porch(lines)	60	35	25	20	16
Front Porch(lines)	37	12	2	1	1
Blank time(lines)	99	49	29	24	20

	6	7	8	9
Format	800x600@56Hz	800x600@60Hz	800x600@72Hz	800x600@75Hz
Pixel Clock(MHz)	36.000	40.000	50.000	49.500
Horizontal				
Sync Polarity	P	P	P	P
Frequency(KHz)	35.156	37.879	48.077	46.875
Total Time(pixels)	1024	1056	1040	1056
Display Time(pixels)	800	800	800	800
	72	128	120	80
Back Porch(pixels)	128	88	64	160
Front Porch(pixels)	24	40	56	16
Blank time(pixels)	224	256	240	256
Vertical				
Sync Polarity	P	P	P	P
Frequency(Hz)	56.250	60.317	72.188	75.000
Total Time(lines)	625	628	666	625
Display Time(lines)	600	600	600	600
Sync Width(lines)	2	4	6	3
Back Porch(lines)	22	23	23	21
Front Porch(lines)	1	1	37	1
Blank time(lines)	25	28	66	25

	10	11	12	13
Format	1024x768@60Hz	1024X768@70Hz	1024X768@72Hz	1024X768@75Hz
Pixel Clock(MHz)	65.00	75.000	78.000	78.750
Horizontal				
Sync Polarity	N	N	N	P
Frequency(KHz)	48.363	56.476	58.036	60.023
Total Time(pixels)	1344	1328	1344	1312
Display Time(pixels)	1024	1024	1024	1024
Sync Width(pixels)	136	136	132	96
Back Porch(pixels)	160	144	164	176
Front Porch(pixels)	24	24	24	16
Blank time(pixels)	320	304	320	288
Vertical				
Sync Polarity	N	N	N	P
Frequency(Hz)	60.004	70.069	71.916	75.029
Total Time(lines)	806	806	807	800
Display Time(lines)	768	768	768	768
Sync Width(lines)	6	6	6	3
Back Porch(lines)	29	29	30	28
Front Porch(lines)	3	3	3	1
Blank time(lines)	38	38	39	32

	14	15	NA	NA
Format	1280x1024@60Hz	1280x1024@75Hz		
Pixel Clock(MHz)	108.000	135.000		
Horizontal				
Sync Polarity	P	P		
Frequency(KHz)	63.981	79.976		
Total Time(pixels)	1688	1688		
Display Time(pixels)	1280	1280		
Sync Width(pixels)	112	144		
Back Porch(pixels)	248	248		
Front Porch(pixels)	48	16		
Blank time(pixels)	408	408		
Vertical				
Sync Polarity	P	P		
Frequency(Hz)	60.020	75.025		
Total Time(lines)	1066	1066		
Display Time(lines)	1024	1024		
Sync Width(lines)	3	3		
Back Porch(lines)	38	38		
Front Porch(lines)	1	1		
Blank time(lines)	42	42		

A : H-Total O : V-Total
 B : H- Sync width P : V- Sync width
 C : H- Back porch Q : V- Back porch
 D : H- Video width R : V- Video width
 E : H- Front porch S : V- Front porch

3.5.6 General performance

3.5.6.1 Maximum pixel clock

135 MHz

3.5.6.2 Maximum luminance

Test conditions: 100% all white pattern, brightness set to Maximum

typical: 250 cd/m2

min : 200cd/m2

3.5.6.3 Brightness variation

Value	75 % Variation (C / A x 100)
Conditions	Display image: Full white Brightness : Maximum Contrast : Maximum A: Luminance at center position

3.5.6.4 Contrast ratio (CR)

Value	CR= B / A
Conditions	Contrast : Maximum Brightness : max B: Full white pattern A: Full black pattern

3.6. ENVIRONMENTS

The environmental conditions are in accordance to IEC 721

Operating:

Temperature: 0°C - +40° C

Humidity: 20% - 80% non-condensing

Height: 3658 m

Air pressure: 700 - 1060 mbar

Storage (unpacked)

Temperature: -20°C - +60° C

Humidity: 8% - 95% non-condensing

Height: 12193 m

Air pressure: 700 - 1060 mbar

Transport (packed)

Temperature: -20°C - +60° C

Humidity: 8% - 95% non-condensing

Height: 12000 m

3.7. REGULATORY STANDARDS

3.7.1 Safety standards

This monitor applies to various safety & EMI standards May refer to the logo label

3.7.2 EMC standards

FCC part 15,subpart B , class-B (EMV) CE marking

3.8. OTHERS

UL, cUL,

3.9. POWER CORD

Northern Hemisphere Version: UL / CSA approved power cord.

European: VDE approved power cord.

3.10. SIGNAL CABLE

Signal cable with Mini D-Sub 15P connectors. Length: 1.8 meter.

3.11. RELIABILITY

> 30000hrs (demonstrated MTBF)

4. THEORY OF OPERATION

This section describes the function of the LCD monitor per functional block.

L9EA monitor includes MB Board (including audio board function inside), power board and button board.

4.1 MB BOARD

The MB board is a two-layer, single-landed design with ground and ground planes provided.

The VGA cable is a signal cable that contains video signal, sync signal and DDC signal from PC VGA adapter. This system board consists of 3 functional areas : flat panel controller, Micro controller and audio controller.

4.1.1 Flat panel controller... Mstar TSU16AK (U3)

The heart of the system board is Mstar TSU16AK. The TSU16AK is a graphics processing IC for LCD monitor. It provides some control functions required for LCD panel. On-chip functions include a high-speed triple-ADC , PLL, high sampling engine and OSD controller.

a) Clock Generation :

Crystal Input Clock (XTALI and XTAL). This is the input pair to an internal crystal oscillator and corresponding logic. A 14.318 MHz crystal is recommended.

b) Hardware Reset (Pin 32)

Hardware Reset signal is generated by MTV312 (U5/Pin 26).It asserts a reset signal at least 1 ms.

c) Analog to Digital Converter

The TSU16AK chip has three ADC's (analog-to-digital converters), one for each color (red, green and blue) . The analog RGB signals are connected to TSU16AK as described below

Pin Name	Pin Number
Red +	63
Red -	62
Green +	60
Green -	59
Blue +	58
Blue -	57

d) OSD :

The TSU16AK has a fully programmable, high-quality OSD controller. The on-chip Static RAM (256 different fonts at size of 12X18) stores the cell map and the cell definitions.

e) Inverter Brightness control (PWM0) (Pin 73)

The TSU16AK has one PWM output PWM0(Pin73) to control Inverter Brightness Range.

f) Panel LVDS interface (Pin 102~103, Pin106~113, Pin118~125, Pin128, Pin1)

The TSU16AK driver interface is highly programmable. It supports LVDS port for panel.

4.1.2 Micro controller.....MTV312 (U5)

The MYSON MTV312 microcontroller serves as the system microcontroller. That is , it programs the TSU16AK and manages other devices in the system such as the keypad, the backlight, LED and audio general purpose input/output pins.

Pin number	Pin name	Pin function
23	P1.5	Key-Sel/Auto
22	P1.4	Key-Menu
16	P6.2	Key-Left
21	P1.3	Key-Power on/off
41	P5.4	LED-Green
9	P6.3	Key-Right
25	P1.7	Key-Down
24	P1.6	Key-Up
29	P3.0/RXD/HSCCL	SCL-VGA/RxD(Debug)
28	P3.1/TXD/HSDA	SDA-VGA/Txd(Debug)
19	P3.2/INT0	INT
18	P1.1	SDA(Debug)
20	P1.2	SCL(Debug)
26	P6.1/AD1	RESET
42	P5.3	LED-Orange
37	P4.1	Audio-Mute
40	P5.5	Audio-Stby-Power
36	P4.0	Inverter On/Off
3	P5.0	Panel power On/Off

4.2 Power Module

The power module includes an Inverter and Power regulator. The electrical specification described as following:

4.2.1 Power Characteristics.

Input	Rated Input Voltage	90~240 Vac,50/60Hz
	Operation Input Voltage Range	90~264 Vac,47~63Hz
	Max Input AC Current	< 1.2A
	Efficiency	12Vdc load 3.5A Brightness Voltage from 0.3~3Vdc ON/OFF Voltage : High(3.3Vdc)/Low(0Vdc)
	Brightness Voltage(Vadj)	0.3Vdc(Max) ~ 3Vdc(Min)
	On/Off Voltage	High(3.3Vdc)/Low(0Vdc)
Output	Static Output Characteristics	12V/3.5A Output : 11.4Vdc ~ 12.6Vdc

4.2.2 Inverter output characteristics.

Rated Output Kick-off Voltage	1500 ~ 2000 Vrms
Rated output Voltage	720Vrms
Rated Output Frequency	40 ~ 60 Khz
Rated Output Current per tube	7mArms

4.2.4 Power module of connector definition ;

CN110 ; Pin 1 & 2 ----> Vdc Output (12V +/- 5%)

Pin 3 & 4 -----> GND

Pin 5 -----> Brightness Control Voltage

Pin 6 -----> On /Off ("High" set Lamp on)

CN1 ~ CN4 ; Pin 1 -----> HV (High Voltage for CCFL)

Pin 2 -----> Return (Low Voltage for CCFL)

5 CONTROL LOCATION

Button Define

1	MENU	OSD Menu	Trigger OSD Main Menu / Clear OSD
2	△	UP	1. Select OSD Main Menu Item 2. Trigger Brightness/Contrast Menu.
3	▽	DOWN	1. Select OSD Main Menu Item 2. Trigger Brightness/Contrast Menu.
4	⏻	POWER	Switch Power ON/OFF
5	◀	LEFT	1. Decrease Menu Item value 2. Trigger Volume Menu.
6	▶	RIGHT	1. Increase Menu Item value 2. Trigger Volume Menu.
7	SELECT/AUTO	SELECT/ AUTO	1. Switch OSD Main Menu focus status. 2. Perform Auto configuration.

LED Status

<i>Color</i>	<i>Status Description</i>
Green	Normal status
Amber	Enter Sleep Mode status or use "Power + Auto" key enter factory mode

Dialog Overview

OSD Main Menu



When user press the **Menu** key under none OSD status will trigger this menu appear for detail parameters adjust. This menu will display about 20 seconds if no one press other key, otherwise will refresh display time length.

Brightness/Contrast Menu

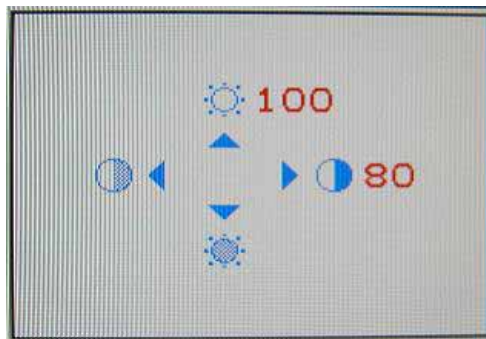

When user press the **Up** or **Down** keys under none OSD status will trigger this menu appear for Brightness and Contrast adjust. This menu will display about 20 seconds.

Auto Configuration

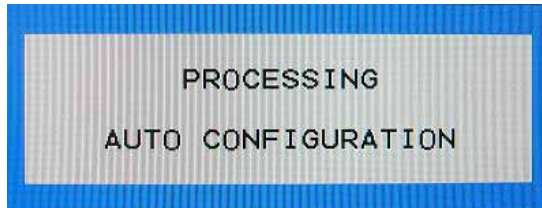

When user press the **select/Auto** key under none OSD status will trigger this dialog appear and perform Auto Configuration procedure.

Mode Information

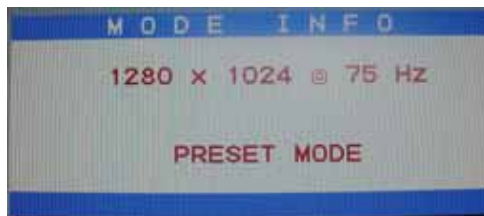

When Display timing changed this dialog will appear about 3 seconds. And this feature only enable when "Information" indicate On in OSD's other page of main menu.

- **No Signal**

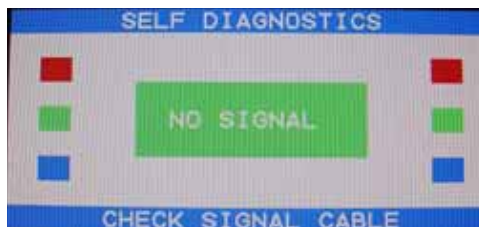

When user does not support the video signal from the cable this dialog will appear about 10 seconds. And then enter the Sleep mode. One special case was in factory mode, the display time length will become 5 seconds for testing the power consumer.

- **Out Of Range**

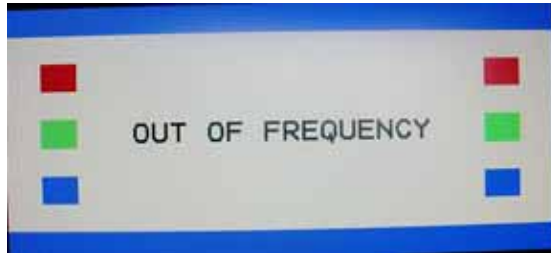

When user input the video signal out of spec this dialog will appear about 10 seconds. And then enter the Sleep mode.

OSD Main Menu

- **Brightness & Contrast Adjustment**



Brightness (Up&Down):

Adjust the brightness of the display.

Contrast (Left&Right):

Adjust the difference between the light and dark areas.

- **Tracking Adjustment**

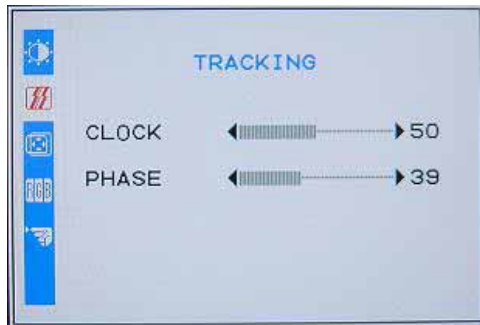

CLOCK:

Adjust to minimize any vertical bars or stripes visible on the screen background. The horizontal screen size will also change.

PHASE:

Adjust to remove any horizontal distortion, and clear or sharpen the image of characters.

- **Position Adjustment**



V-Position:

Adjust the vertical position of the picture.

H-Position:

Adjust the horizontal position of the picture.

● Color Adjustment

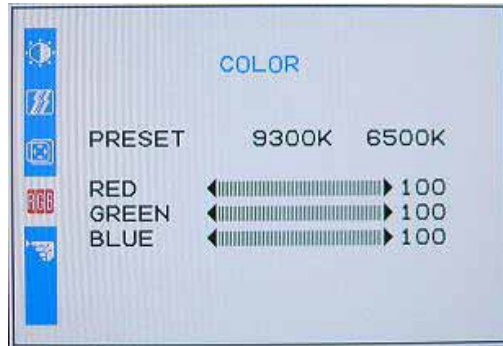

There are four items for color adjustment:

9300K: Bluish white

6500K: Reddish white

User defined:

Red, Green, Blue. Adjust to set your own color level.

Other



LANGUAGE:

Multi- Language selection

OSD POSITION:

Adjust the OSD window position on the screen.

INFORMATION:

Display Information Dialog or not when input timing changed.

RESET: Recall to factory settings.

- **Factory1 Adjustment**



This page only visible in factory mode

R,G,B OFFSET :

Adjust current RGB cut off level

R,G,B GAIN :

Adjust current RGB Driver value.

SSPLL and SSMOD :

Adjust chip set internal frequency spread effect for EMI testing.

- **Factory2 Adjustment**

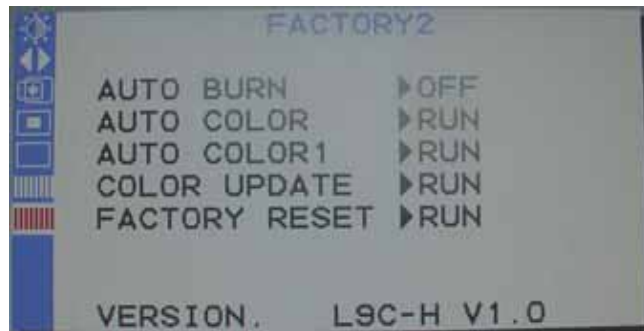

This page only visible in factory mode

AUTO BURN :

Use the chip set internal pattern for hot running monitor panel and inverter.

AUTO COLOR :

Perform Auto Balance measurement .

AUTO COLOR 1 :

Perform Auto Balance measurement by chip set internal signal. And reference these values to initial all other color temperature detail parameters.

COLOR UPDATE :

Force presently R,G,B offset and gain parameters update to currently temperature memory address.

FACTORY RESET :

Recall to factory setting and power off immediately.

VERSION :

Display F/W version.

6. NECESSARY EQUIPMENT LIST

Item

- 1 Personal Computer with Windows 98/95
- 2 Luminance Meter Minolta CA 110
- 3 Video Generator : Chroma 2000,2135,2250 or equivalent
- 4 Color Analyzer : Minolta CA110 , Chroma or equivalent
- 5 Watt / Power Meter
- 6 10 Times Magnifier
- 7 Ruler /Template
- 8 Thickness gauge

7. BLOCK DIAGRAM

7.1 Power module

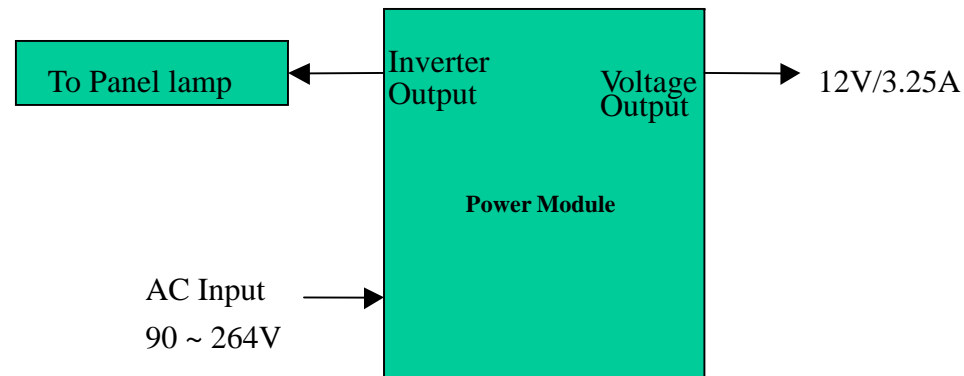

7.2 Main Board

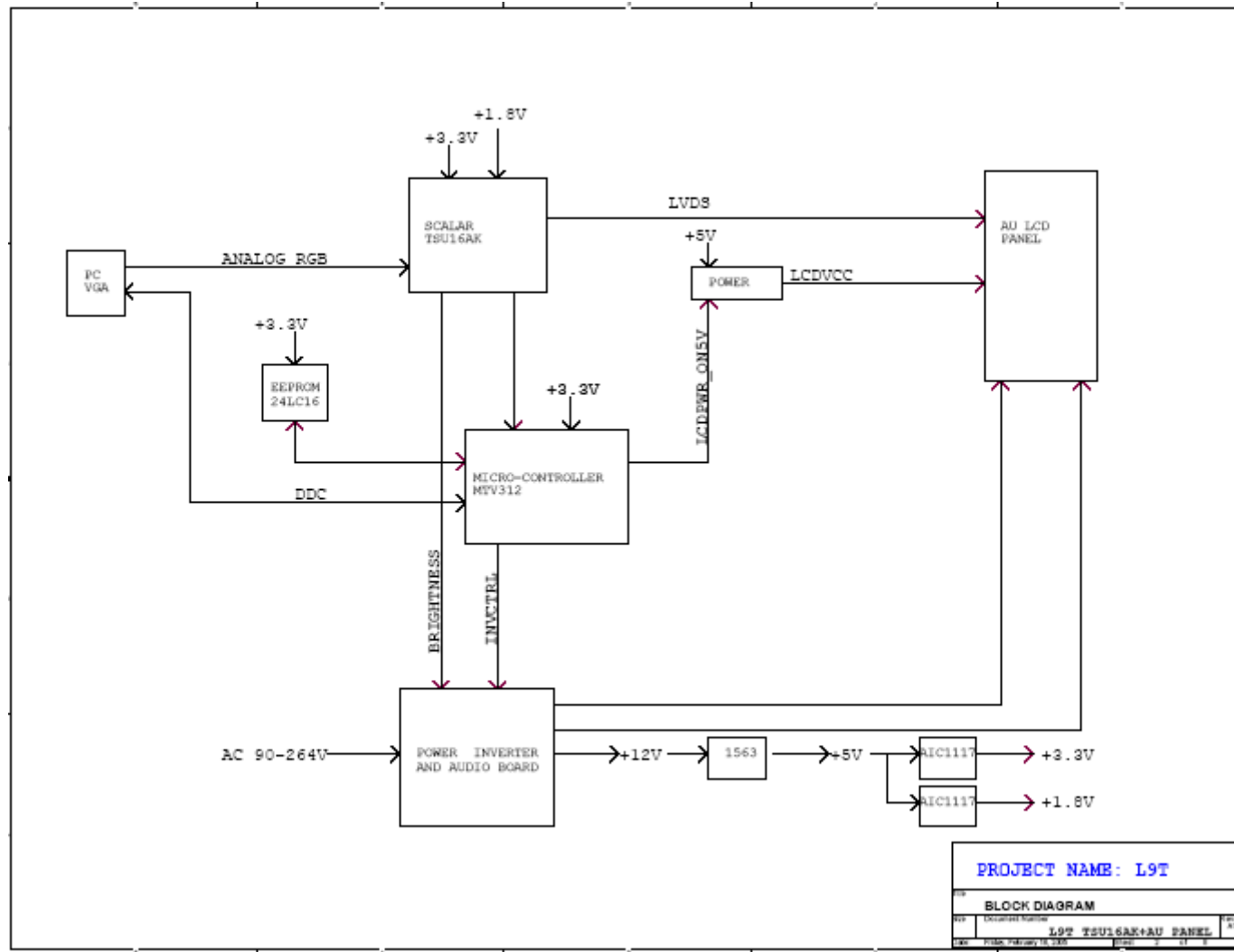

8. CONDUCTOR VIEW

Main Board Silkscreen

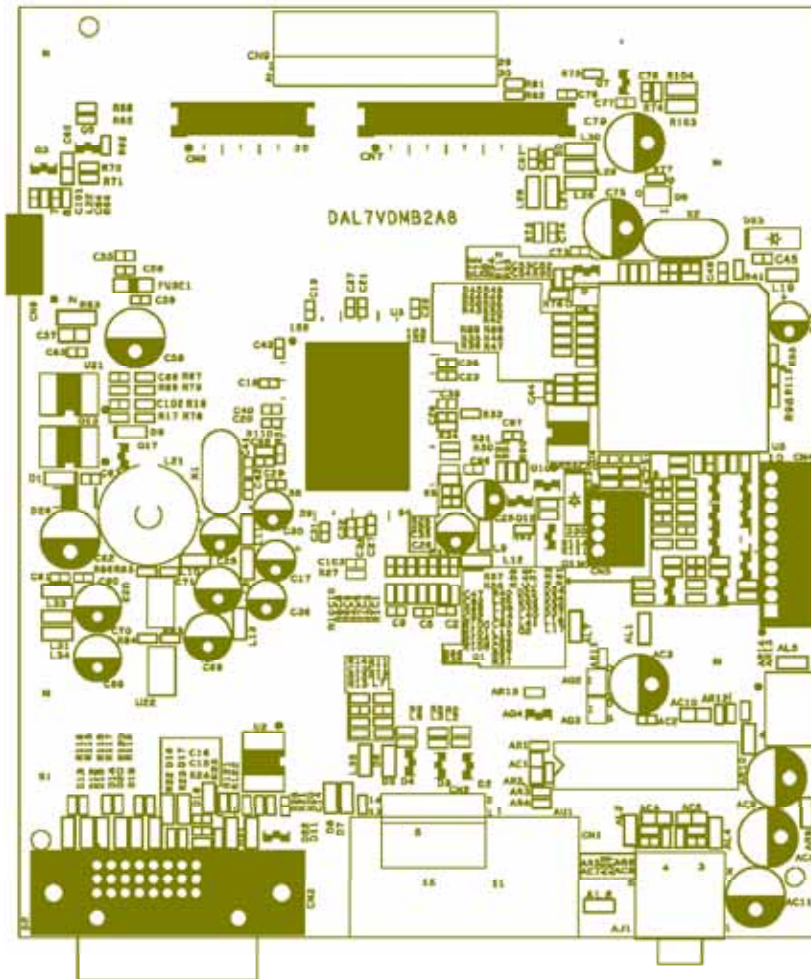

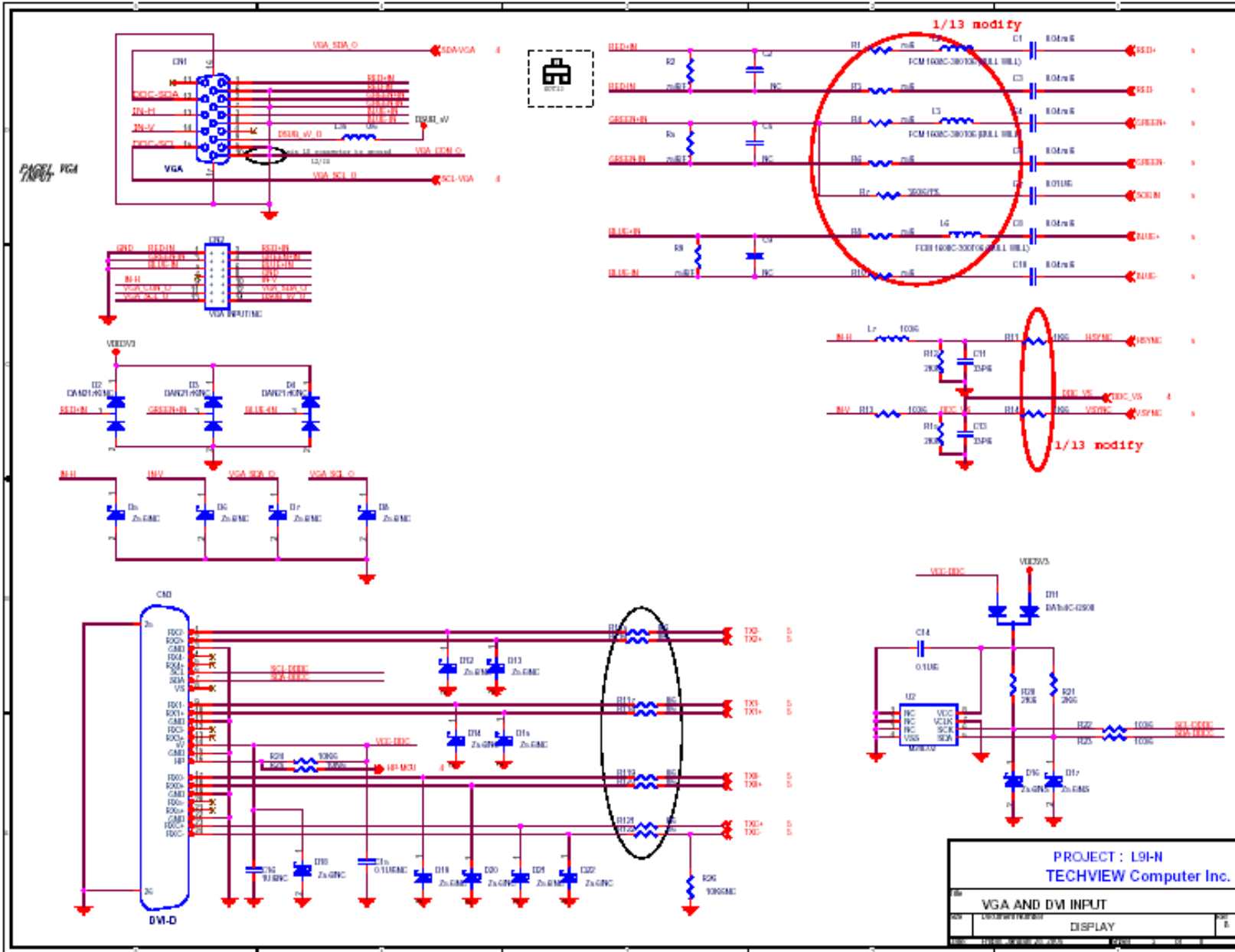

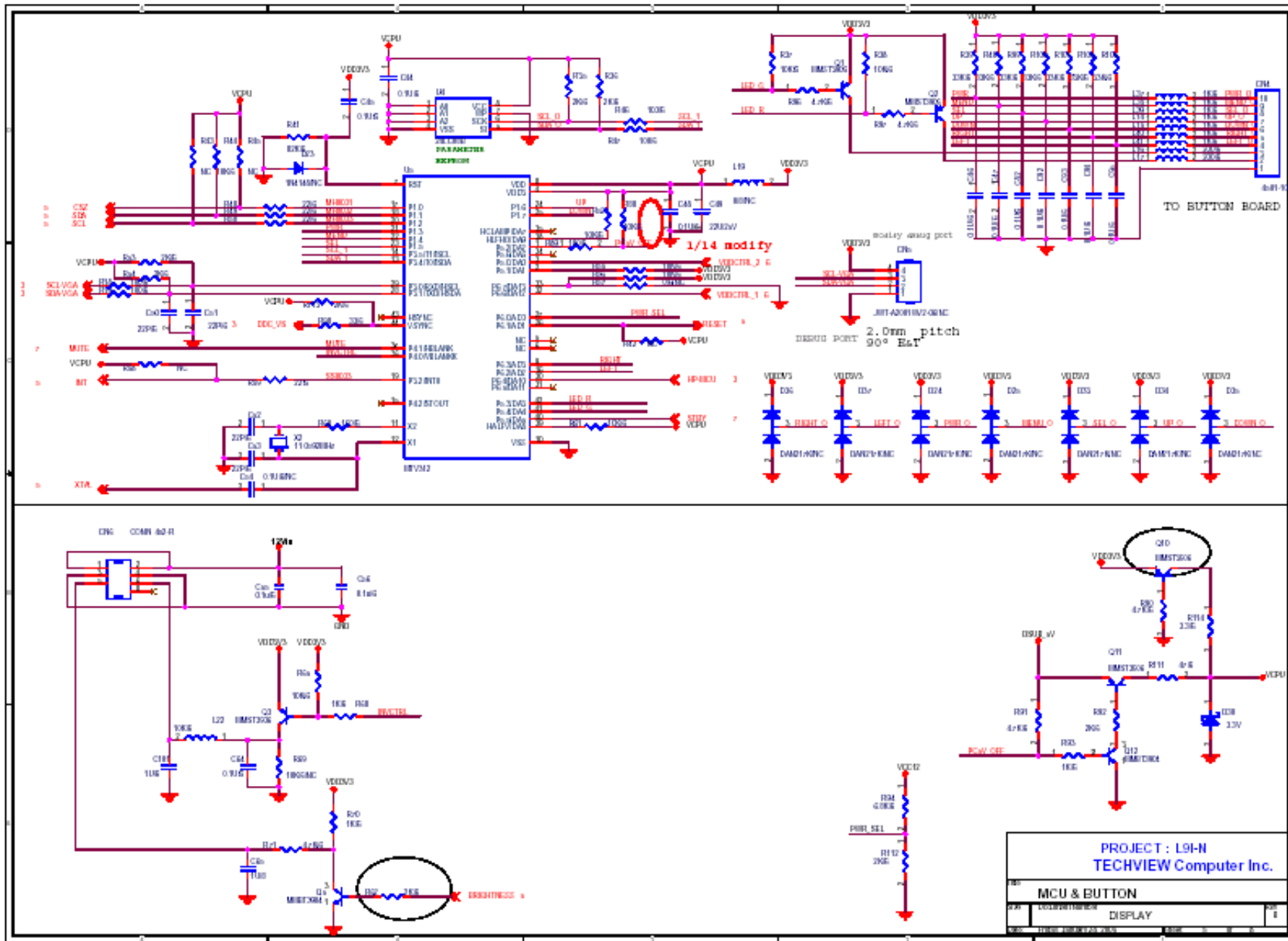

Power Board Circuit

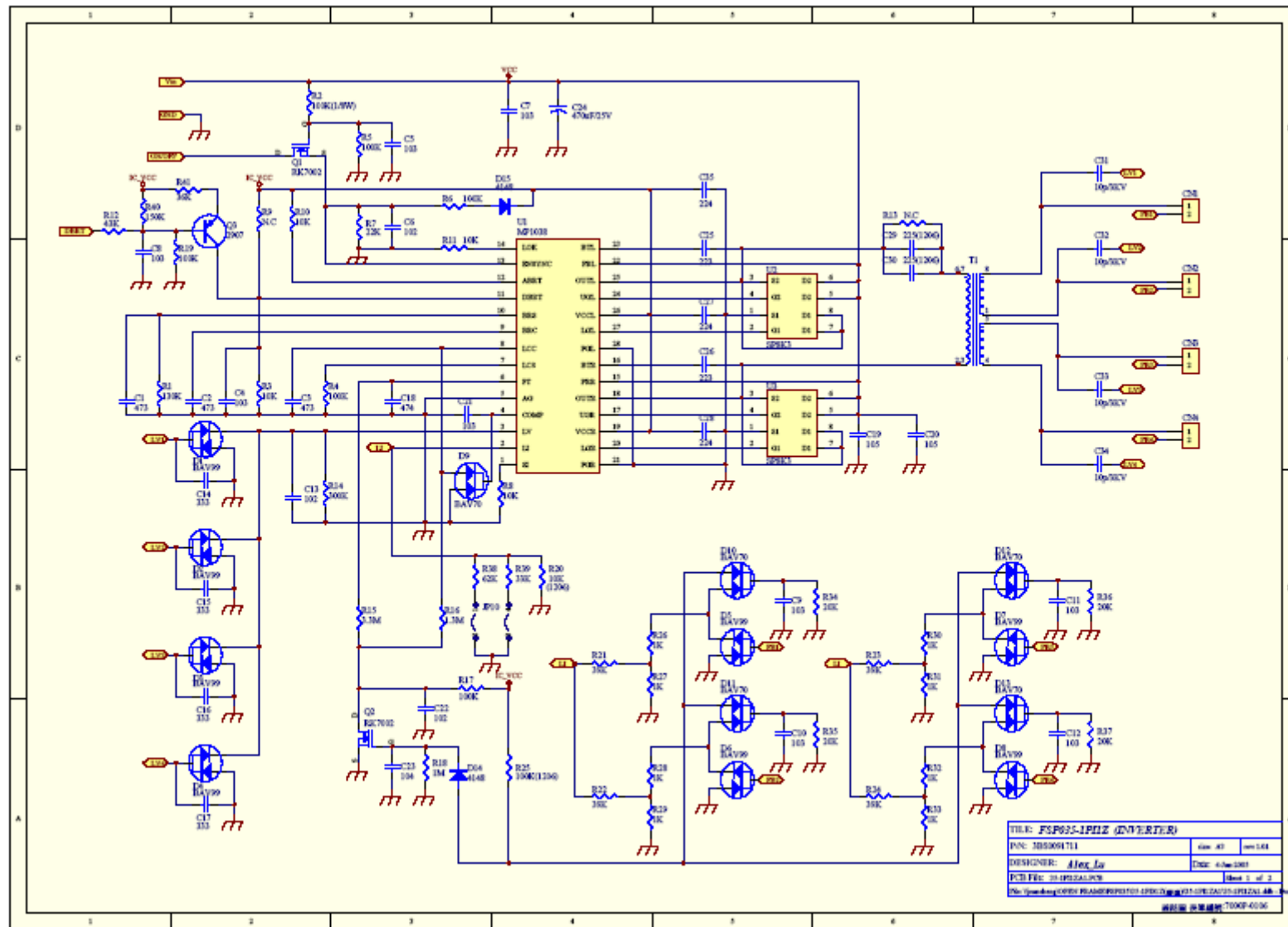

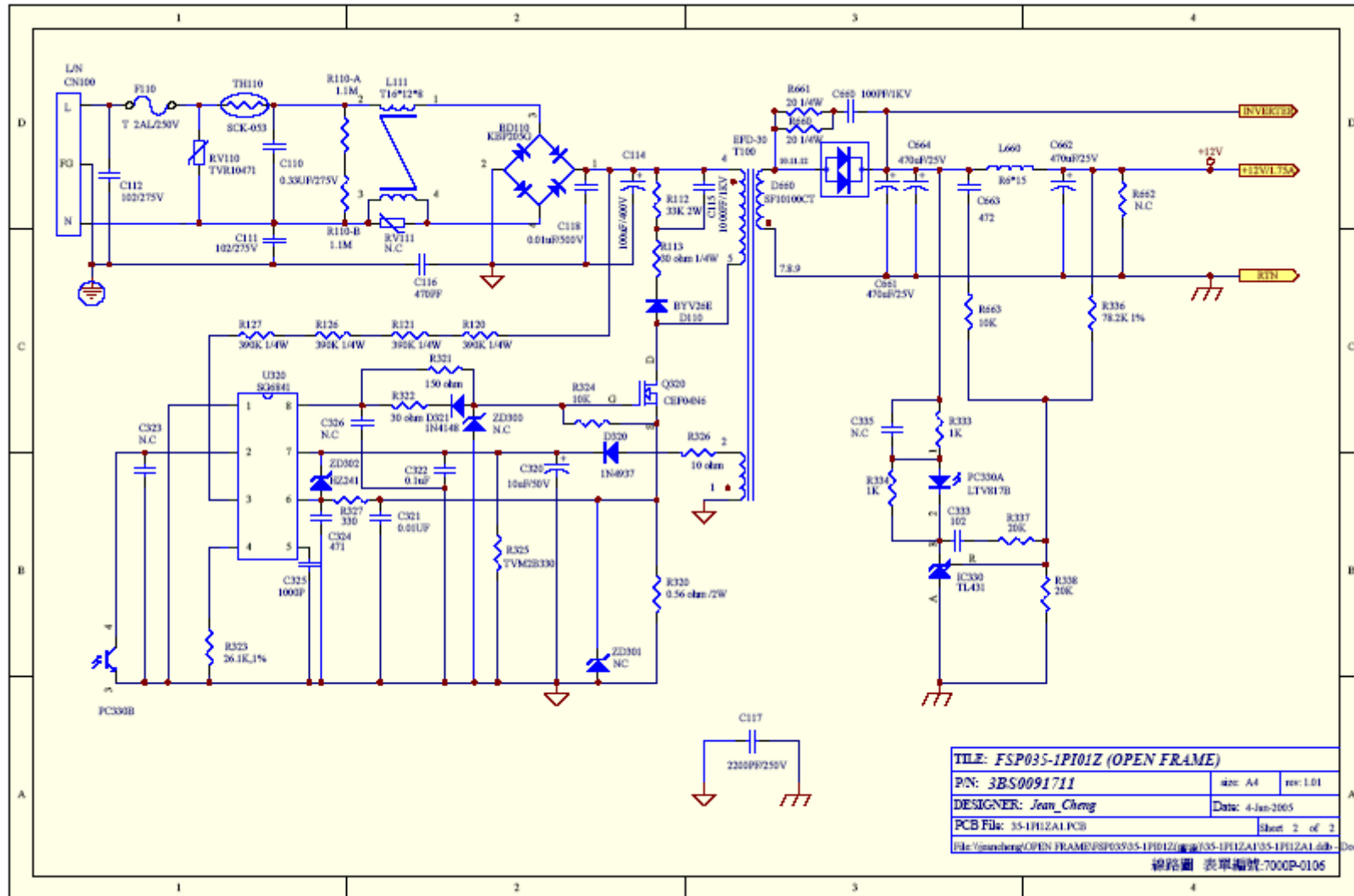

11 TROUBLE SHOOTING HINTS

1.No power

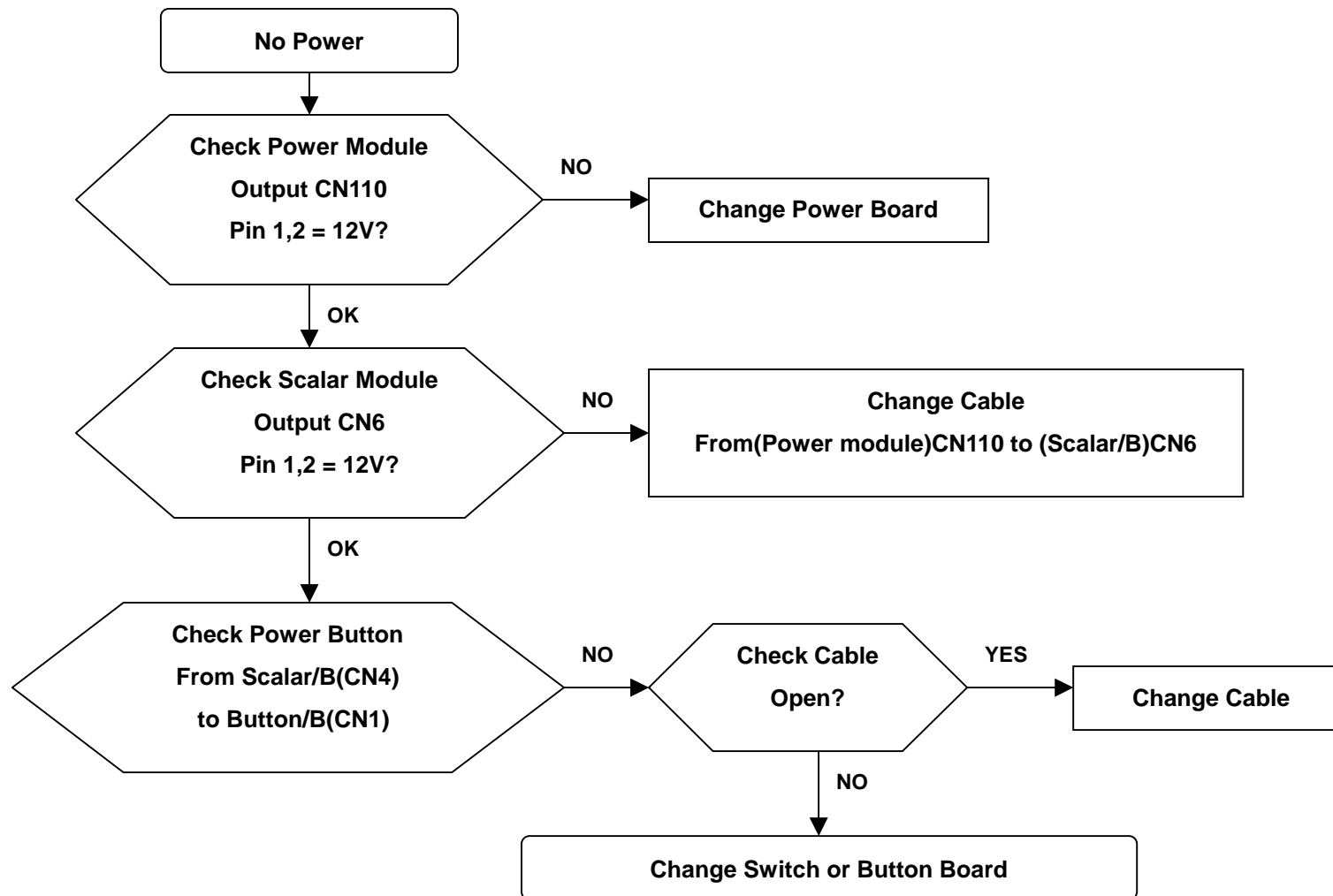

2.No Characters , Missing one color

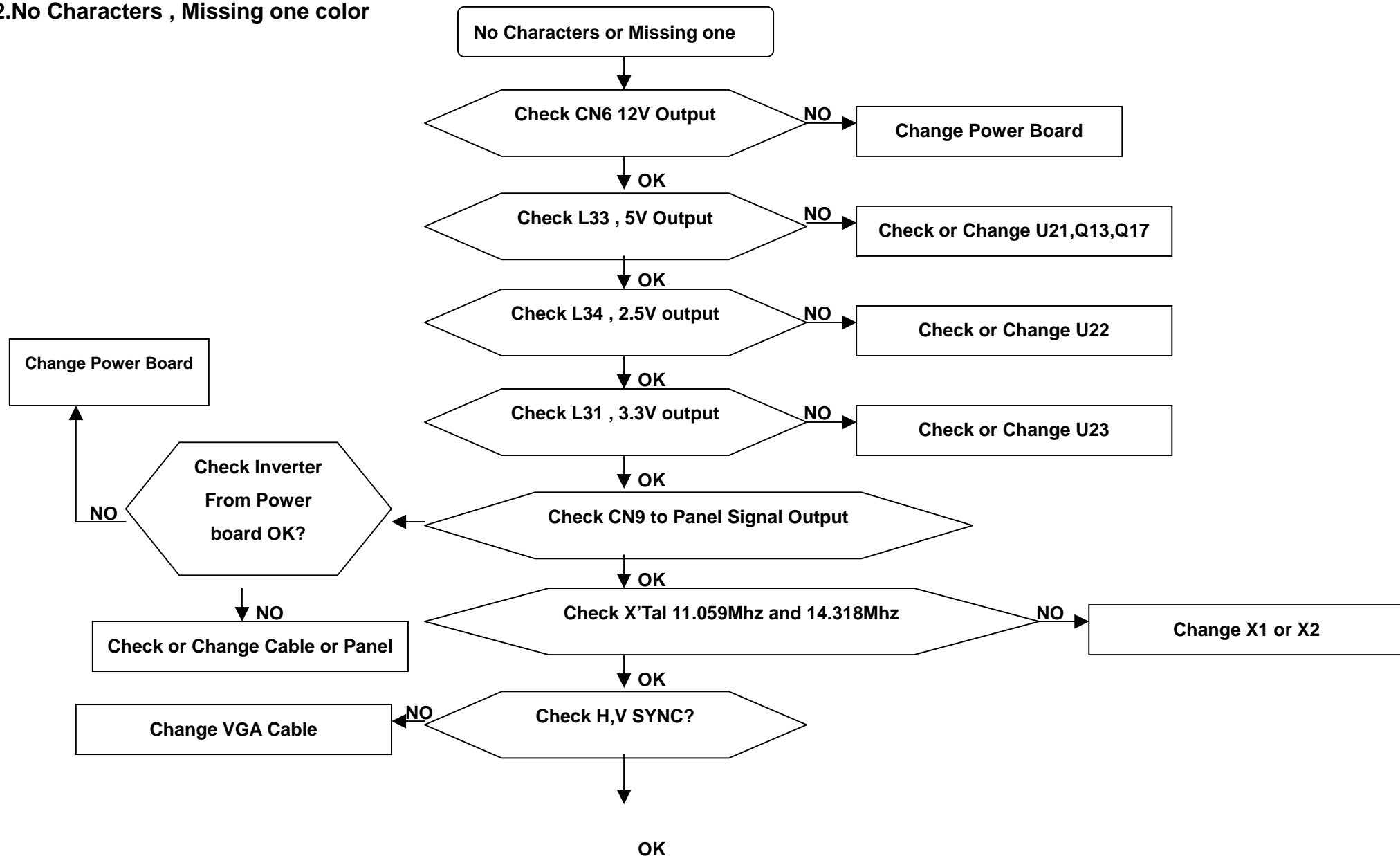

12. REPLACEMENT PARTS LIST(See appendix)

13.Auto White Balance Procedure

- 1 Connect signal to monitor. The display signal need contain real black and full white.
- 2 Press "Auto" button(don't release) when power ON(LED display Amber).
- 3 Press OSD select FACTORY 2, Auto Color, RUN(For AD converter calibration on R, G and B gain, offset).
- 4 Select Color Update, RUN.
Press OSD select COLOR into 6500 and check by color analysis (If adjustment Press OSD select FACTORY 1 for
- 5 Adjust the R, G, B gain. Please make color update when finished adjustment on 6500)
Press OSD select COLOR into 9300 and check by color analysis (If adjustment Press OSD select FACTORY 1 for
- 6 Adjust the R, G, B gain. Please make color update when finished adjustment on 9300)
Please make sure that Brightness set 100, Contrast set 80 when adjust(factory default).
The adjustment result needs to be checked by Color Analysis like CA110, the input signal 0.7V
* and full white pattern while on check.