

SAFETY GUIDELINES:

Please read and follow the following safety guidelines:

Before beginning any exercise program, you should consult with your doctor. It is recommended that you undergo a complete physical examination.

- . Read this owner's manual and follow the instructions.
- . Assemble and operate the treadmill on a solid, level surface. Keep the area behind the treadmill clear.
- . Never allow children on or near the treadmill. The treadmill running belt will not stop immediately if any object becomes caught in the belt or rollers.
- . Check the treadmill before every use. Make sure all parts are assembled, and all nuts and bolts are tightened. Do not use the treadmill if the unit is disassembled in any way.
- . Keep hands away from moving parts.
- . The weight limit for this treadmill is 275 LBS. (125 KGS).
- . Make sure the treadmill has come to a complete stop and the incline display shows "0" before folding.
- . Wear proper workout clothing: Do not wear loose clothing. Do not wear shoes with leather soles or high heels. Tie back all long hair.
- . Don't rock the unit from side to side. Care should be taken when mounting and dismounting the unit.
- . Straddle the machine with your feet on the right and left staging platforms before starting the running belt.
- . Do not place any liquids on any part of the treadmill.
- . To prevent shock, keep all electric components, such as the motor, cord, and switch away from water.
- . Do not use any accessories that aren't specifically recommended by the manufacturer, these might cause injuries or cause the unit to fail.
- . Work within your recommended exercise level, do NOT work to exhaustion.
- . If you feel any pain or abnormal sensation, STOP YOUR WORKOUT and consult your physician immediately.
- . Turn off the treadmill while adjusting or working near the rear roller.

Warning—To reduce the risk of burns, fire, electric shock, or injury to persons:

- . A treadmill should never be left unattended when plugged in. Unplug from outlet when not in use, and before putting on or taking off parts.
- . Close supervision is necessary when this treadmill is used by, on, or near children, invalids, or disabled persons.
- . Use this treadmill only for its intended use as described in this manual.
- . Never operate this treadmill if it has a damaged cord or plug, if it is not working properly, if it has been dropped or damaged, or dropped into water. Return the treadmill to a service center for examination and repair.
- . Do not carry this treadmill by supply cord or use cord as a handle.
- . Keep the cord away from heated surfaces.
- . Never operate the treadmill with the air openings blocked. Keep the air openings free of lint, hair, and the like.
- . Never drop or insert any object into any opening.
- . Do not use outdoors.
- . Do not operate where aerosol (spray) products are being used or where oxygen is being administered.
- . To disconnect, turn all controls to the off position, than remove plug from outlet.
- . Connect this treadmill to a properly grounded outlet only.

The treadmill is designed for the use and enjoyment. By following the above precautions and using good judgment and common sense, you will enjoy safe and pleasurable exercise with this treadmill.

TABLE OF CONTENTS

1. SAFETY GUIDELINES.....	1
2. INTRODUCTION.....	3
3. ASSEMBLING YOUR TREADMILL	
Installation Requirements.....	5
List of parts.....	5
Step by step instruction.....	6
Floor level adjustment.....	11
Folding the treadmill.....	12
Unfolding the treadmill.....	13
4. OPERATING INSTRUCTIONS	
Safety key.....	13
5. UNDERSTANDING THE ELECTRONIC PACKAGE	
Key functions.....	14
What each of the categories means.....	15
6. RUNNING ON THE TREADMILL.....	16
7. GUIDELINES FOR EXERCISE	
How long should I exercise?.....	17
How often should I exercise?.....	17
8. MAINTAINING YOUR TREADMILL	
Cleaning the treadmill.....	17
Adjusting the running belt.....	18
9. TROUBLE SHOOTING	
ERR messages.....	21
Blank display.....	22
Electronics package and motor fuse failure.....	23
Fuse Failure For Incline System.....	24
Fuse failure for drive board.....	24

INTRODUCTION:

Congratulations on purchasing one of the finest pieces of exercise equipment on the market today. Constructed of high quality materials and designed for years of trouble free usage. We hope this treadmill will be an integral part of your fitness regimen.

Before using your Treadmill, we recommend that you familiarize yourself with this Owner's Manual. Whether you are a first time user of exercise equipment or a seasoned "pro", understanding the correct use of the equipment will enhance your ability to achieve your exercise goals safely and successfully. Below is the drawing of this treadmill.

ITEM:1250

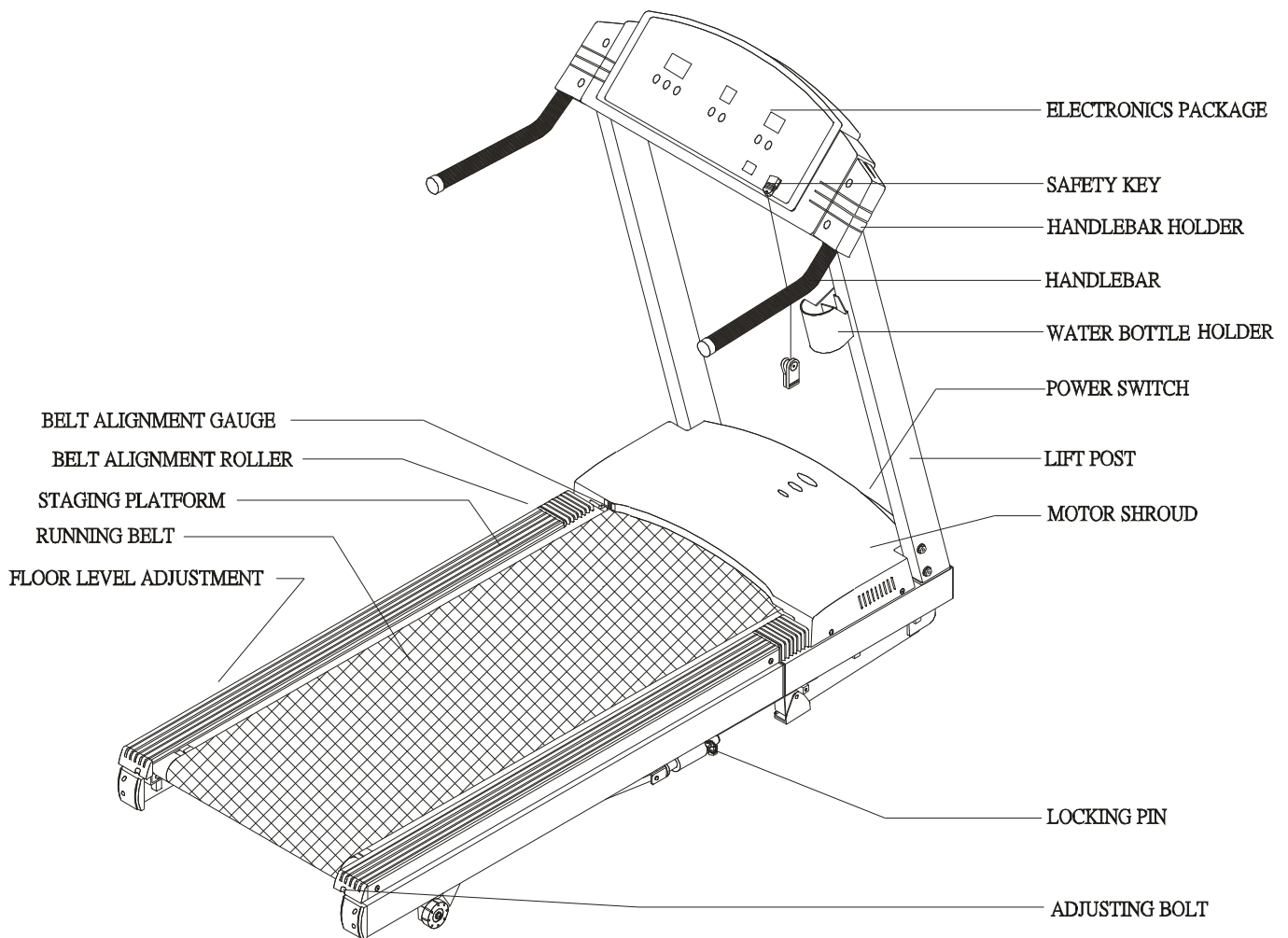

ITEM:1250L

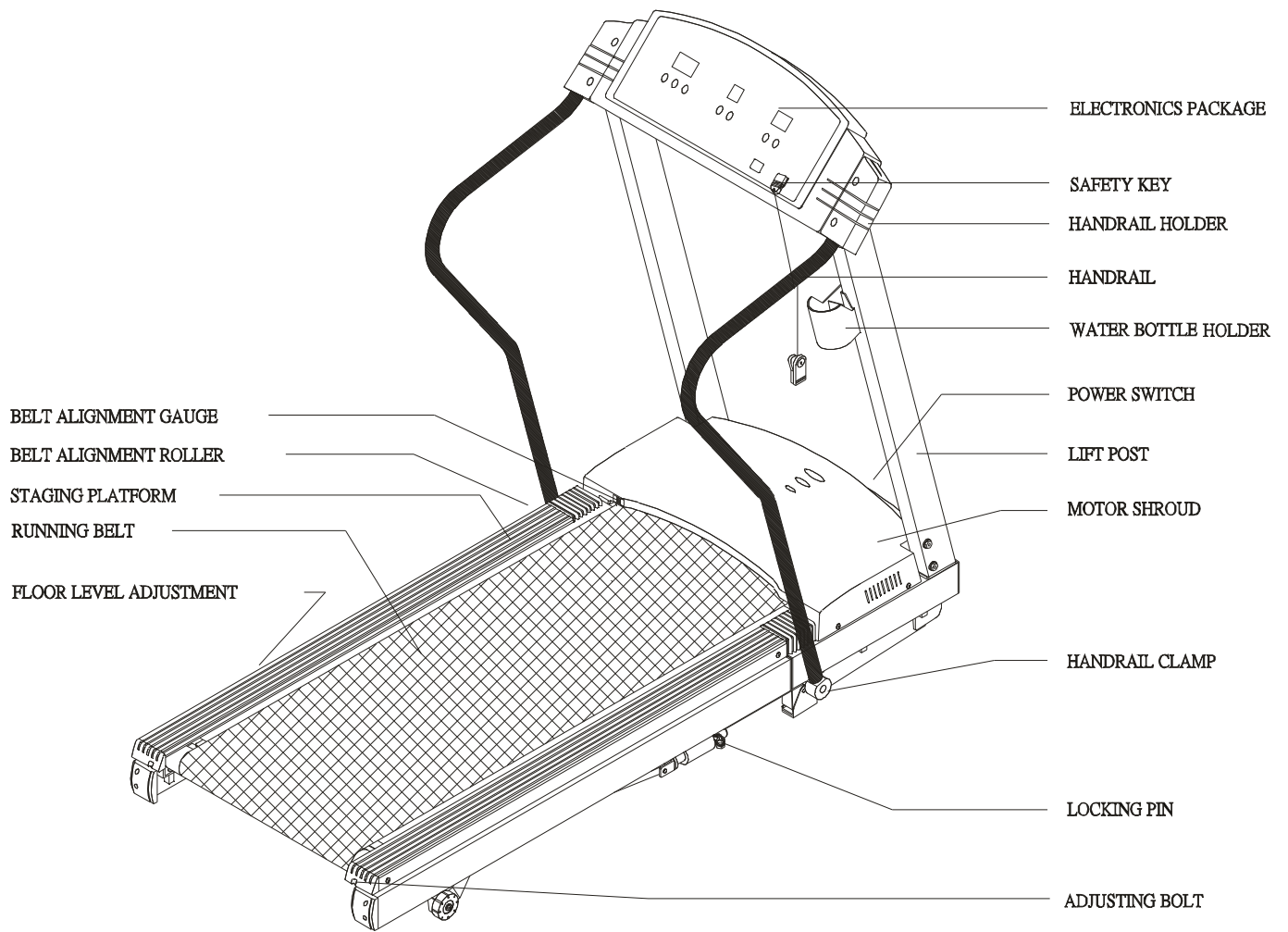

ASSEMBLING YOUR TREADMILL:

Installation Requirements

Read this owner's manual and follow the instruction contained herein.

CAUTION: To avoid back strain, and to insure safety to the unit and yourself, we suggest you may need a helper to remove the running deck assembly from box.

List of parts

Before assembling your treadmill, make sure that you have all the following items:

1. Eight 5/16" x 3/4" bolts-lift post
2. Eight 5/16" nylon washers-lift post
3. Eight 5/16" washers-lift post
4. Four 1/4" x 1 1/4 " bolts-handrail / handlebar holder
- 4A. Two 5/16" bolts-handrail clamp (for 1250L only)
5. Two 1/4" x 1/2 " screws-water bottle holder
6. One water bottle holder
7. One safety key
8. One hex Allen wrench
9. One hex Allen wrench with handle
10. One combination wrench
11. Three fuses
 - a. 12A (100V/120V use) or 7A (200V/240V use) - Electronics and Motor
 - b. 1A (100V/120V use) or 0.5A (200V/240V use) - Incline system
 - c. 0.5A - Drive board

If any items are missing, contact your authorized service dealer.

IMPORTANT: The packing for this treadmill was designed to protect it during shipment. Please store the original packaging in a safe place in case you need to ship the treadmill in the future.

Step by step instructions

The following steps explain how to assemble your treadmill. Please read every step thoroughly, and follow the directions completely to ensure correct assembly.

1. Fold the treadmill. Then discard the 4 blocks after removing them from both sides (see Fig.1).

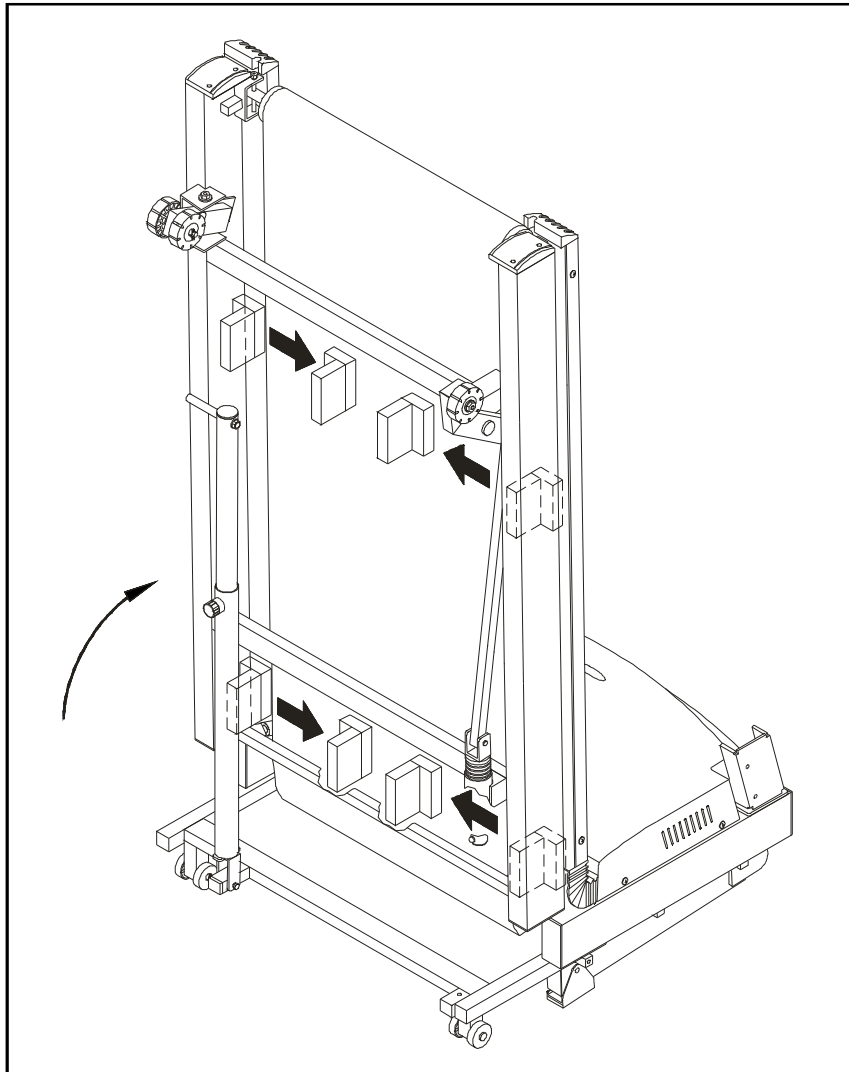
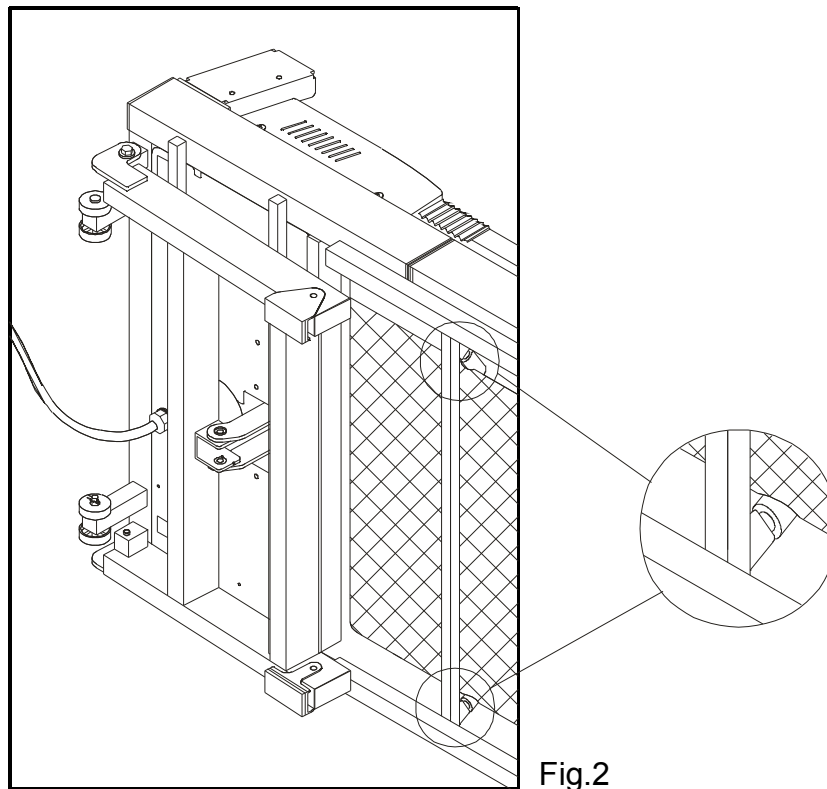

Fig.1

2. There are important parts enclosed inside of the Styrofoam, please check Styrofoam compartments before discarding. Make sure all packing materials are removed from the treadmill deck.

3. Lay the treadmill on its side. Make sure the running belt is position in the tracks of the two BELT ALIGNMENT ROLLERS underside of the machine (see Fig. 2).



4. Then, place the treadmill on a level, flat surface.
5. Insert the two front posts into their respective sockets and secure with four bolts and washers provided on each side (see Fig. 3).

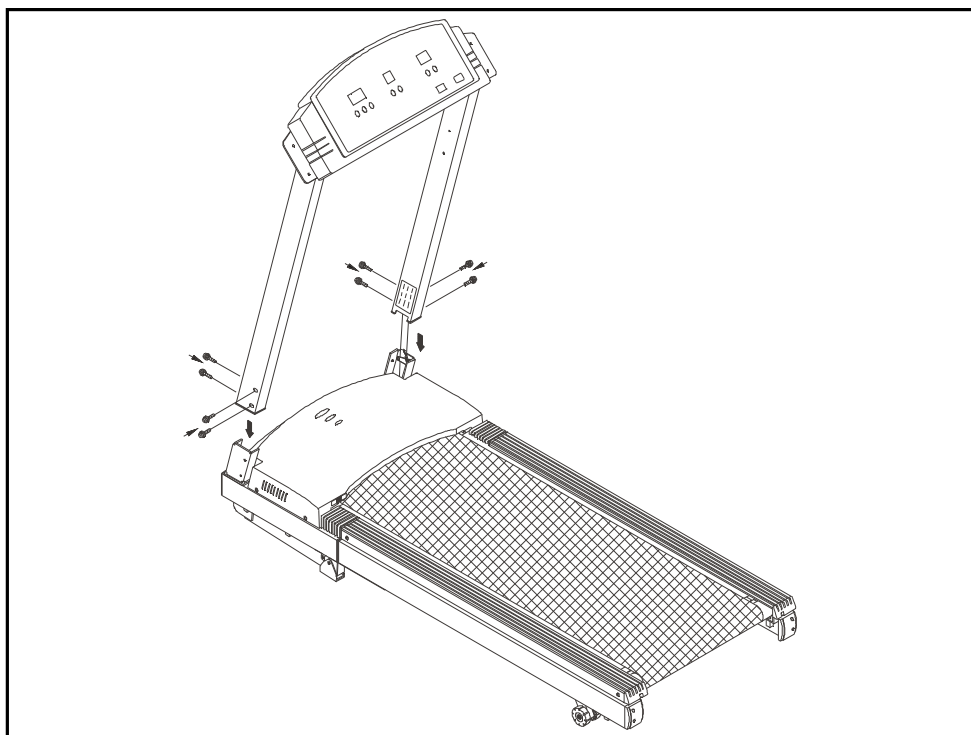

6. Attach the handlebars or the end of the handrails to their holders, do not tighten the bolts yet (see Fig. 4).

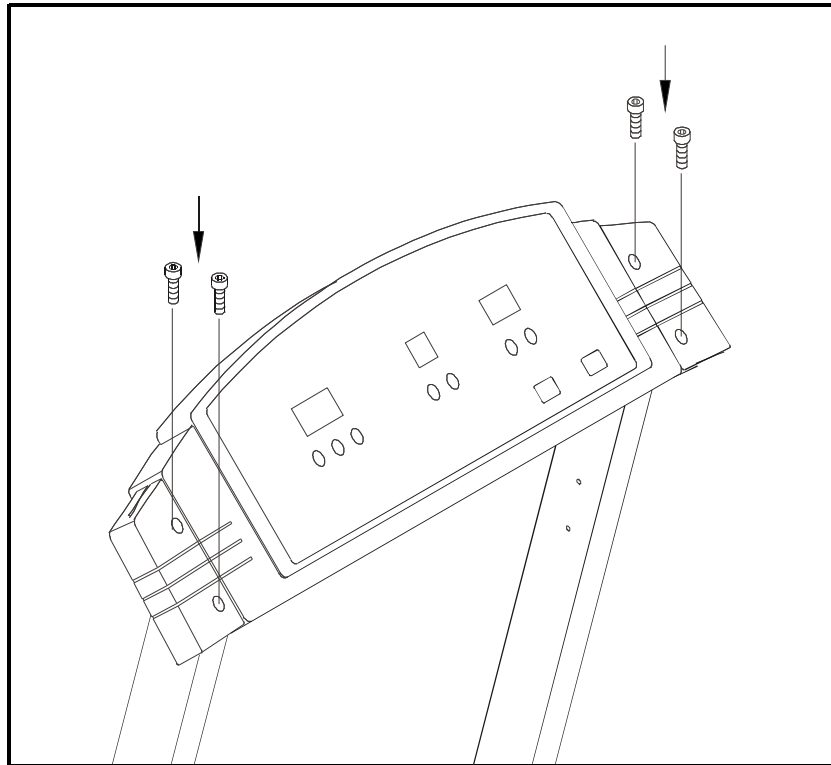

Fig.4

7. Making sure that the notches in the handlebars or handrails fit into the holder channel (see Fig. 5).

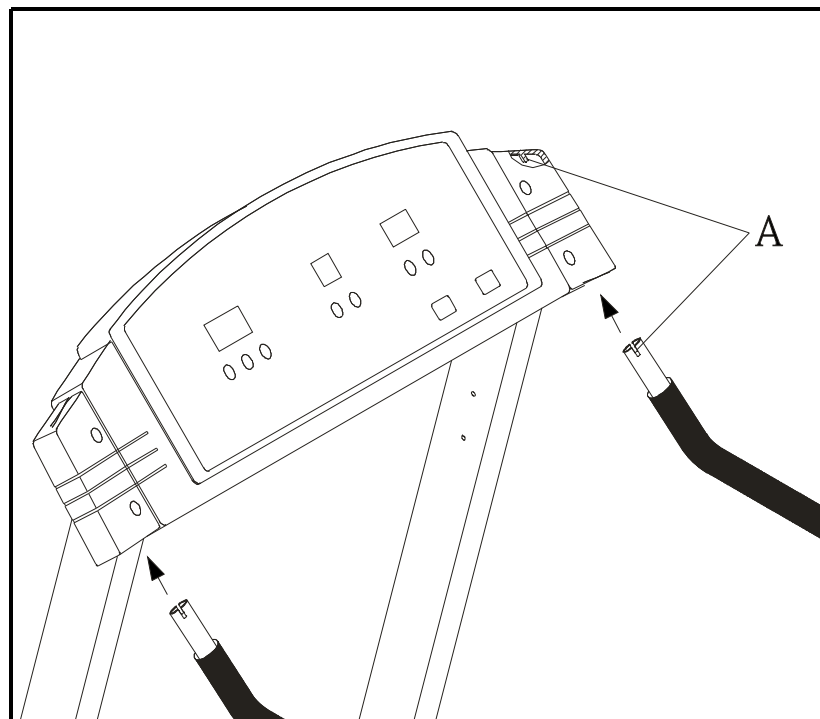

Fig.5

8. Then, secure with screws provided (see Fig. 6).

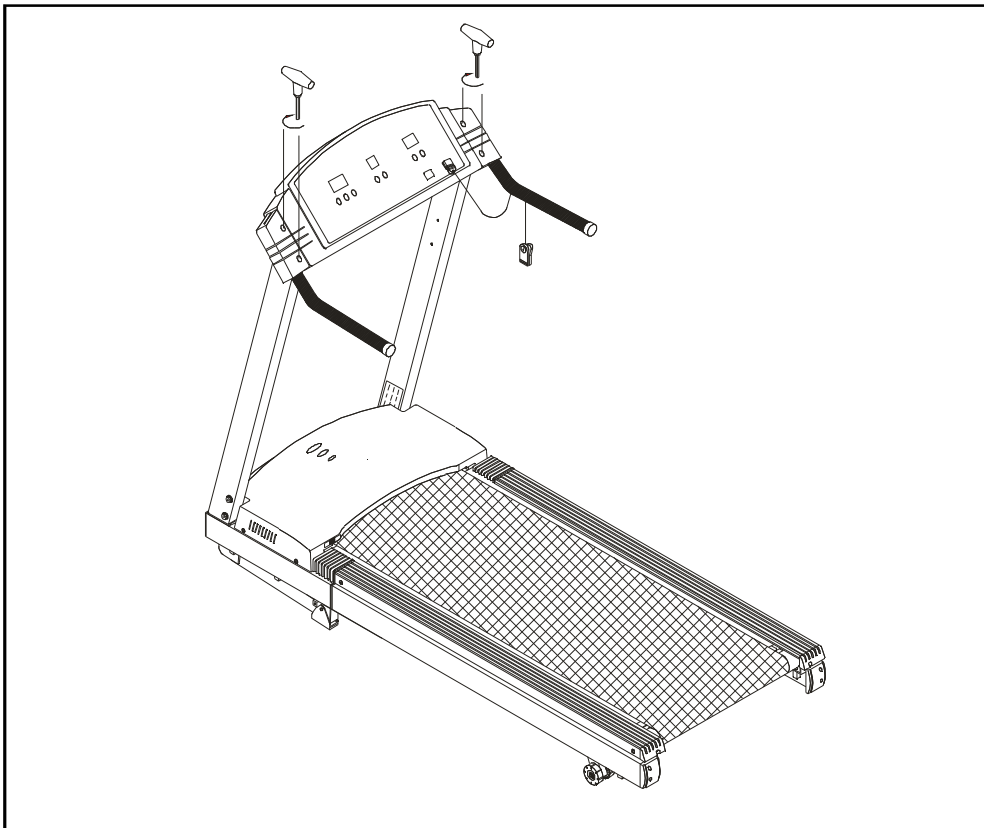

Fig.6

9. If the unit with handrails, attach the bottom of the handrails with handrail clamps to the treadmill frame secure with one bolt on each side (see Fig. 7). Then, tighten the upper handrails bolts securely.

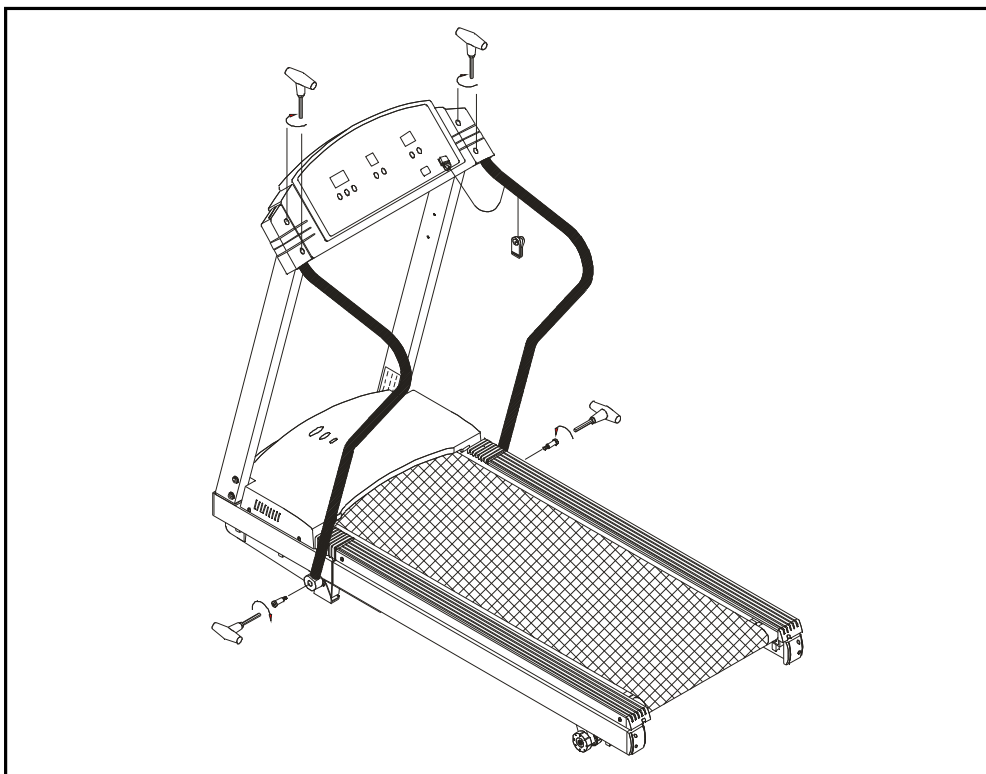
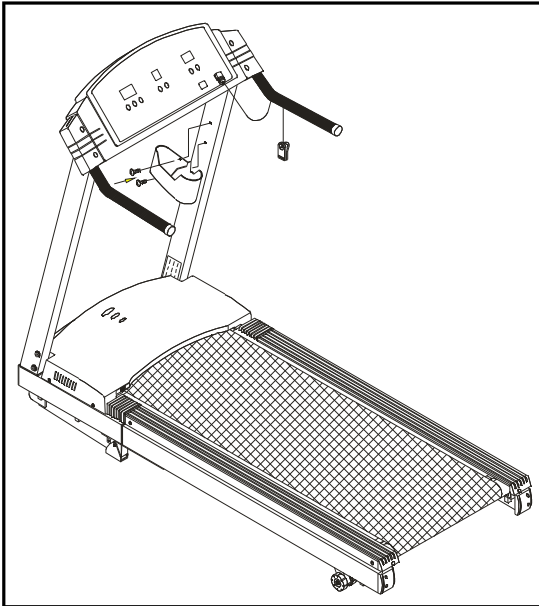

Fig.7

10. Assemble the water bottle/personal stereo holder to the right front post using the screws provided.(see Fig.8)

ITEM:1250



ITEM:1250L

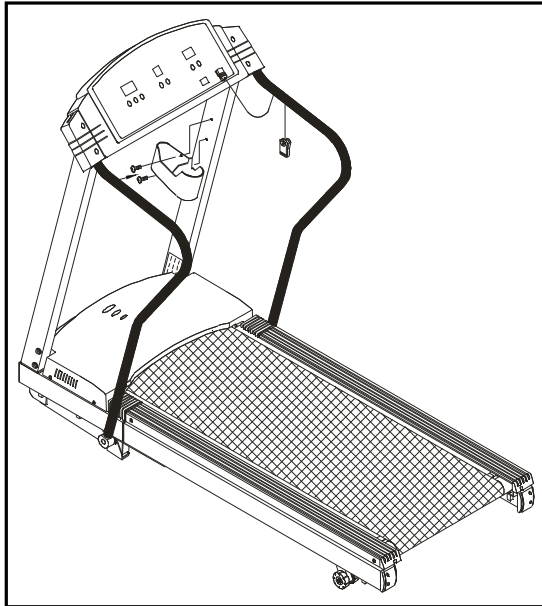
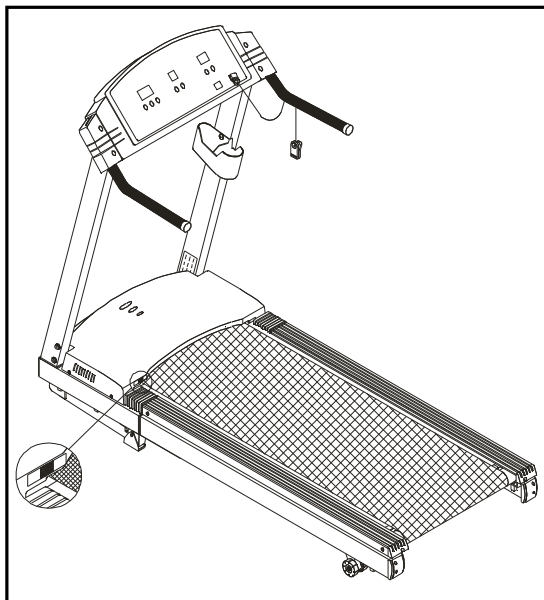

Fig.8

IMPORTANT: Before using the treadmill, the left edge of the running belt must be completely in the green portion of the BELT ALIGNMENT GAUGE, located on the left side of the motor shroud. Please refer to the "Maintaining treadmill" section "Adjusting the running belt" for further information.(see Fig. 9).

ITEM:1250



ITEM:1250L

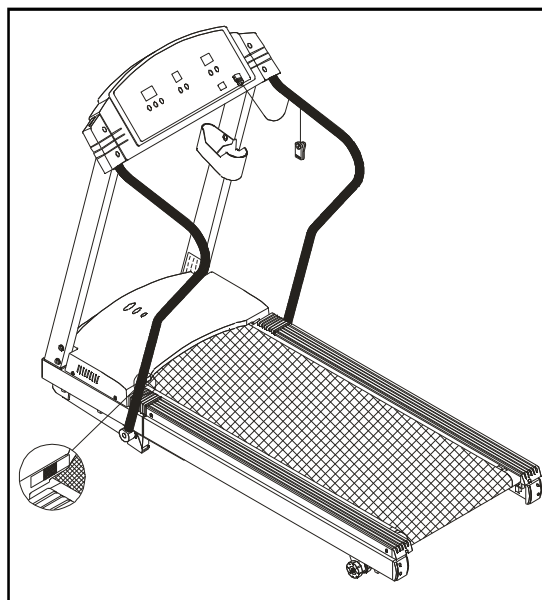

Fig.9

NOTE: After your treadmill is assembled completely, place the safety key onto the "SAFETY KEY" position on the electronics package in order for the unit to function. Please refer to the "OPERATING INSTRUCTION" section "Safety key" for further information.

Floor level adjustment

If the treadmill is not steady on your floor, turn the FLOOR LEVEL ADJUSTMENT on the rear left leg of the treadmill. Use a hex Allen wrench to raise or lower the floor level adjustment to steady your treadmill (see Fig. 10).

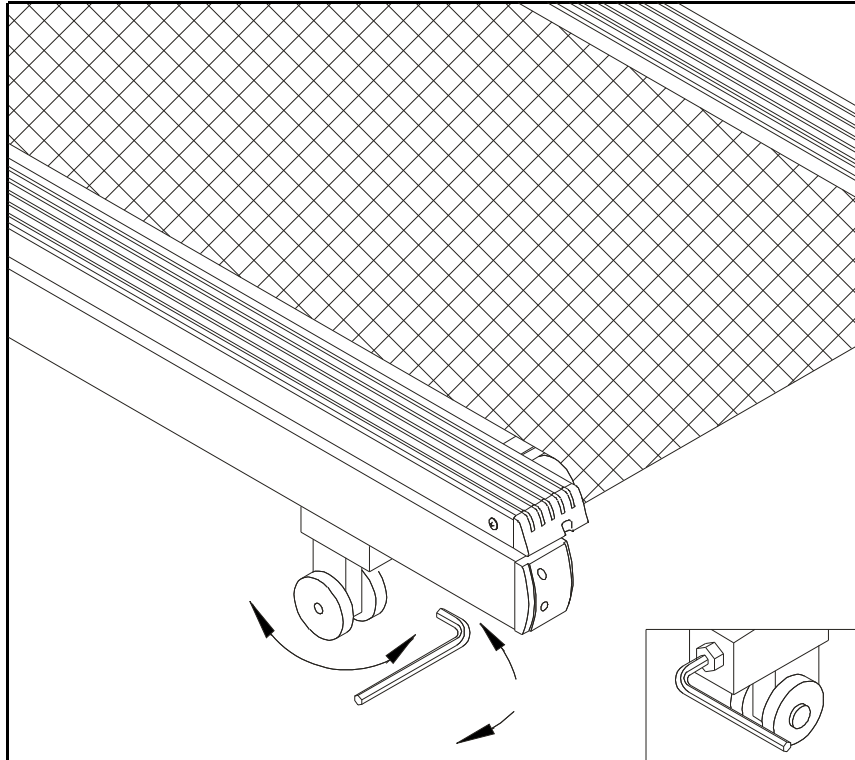

Fig.10

Your treadmill is assembled and ready to use.

Folding the treadmill

1. Discard the pin before folding the treadmill (see Fig. 11).

ITEM:1250

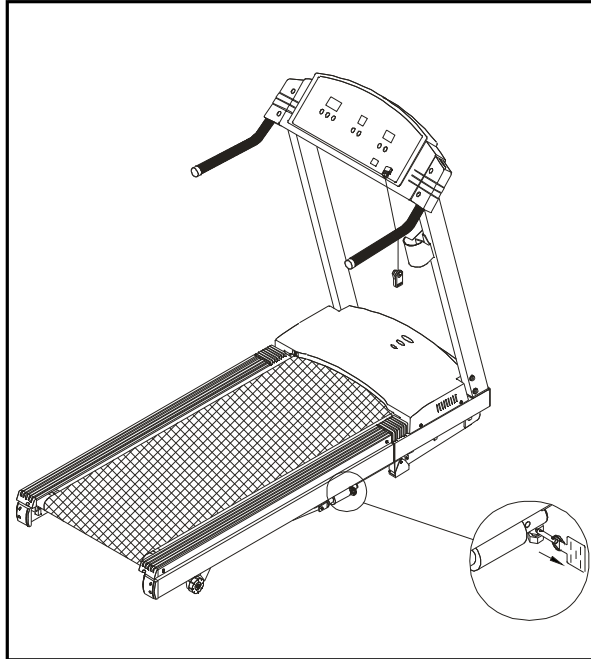

ITEM:1250L

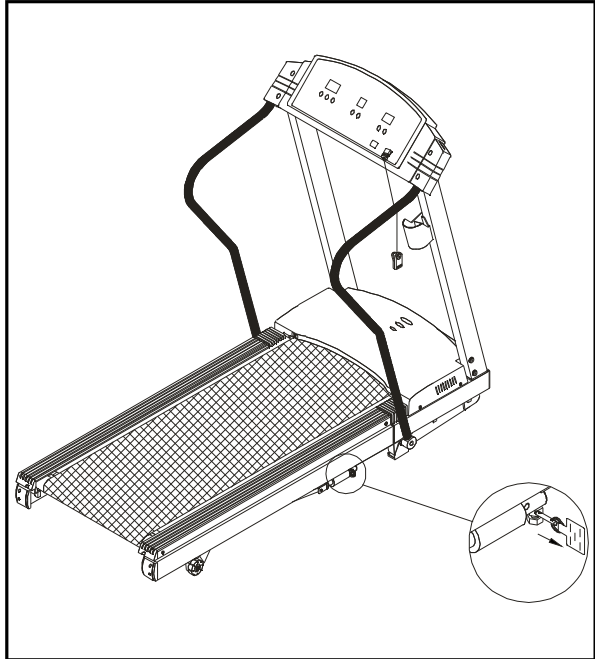
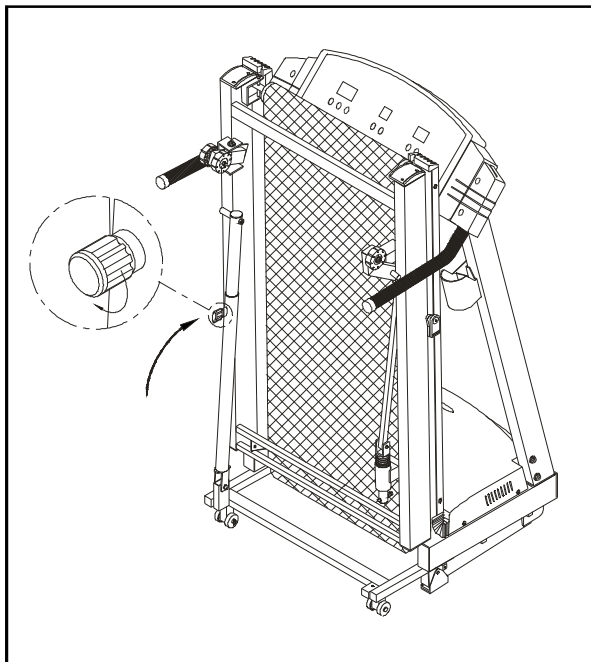

Fig.11

2. Lift the end of the treadmill bed to fold into its upright position, locate the locking nut below the running deck, turning the knob clockwise to secure (see Fig. 12).

ITEM:1250



ITEM:1250L

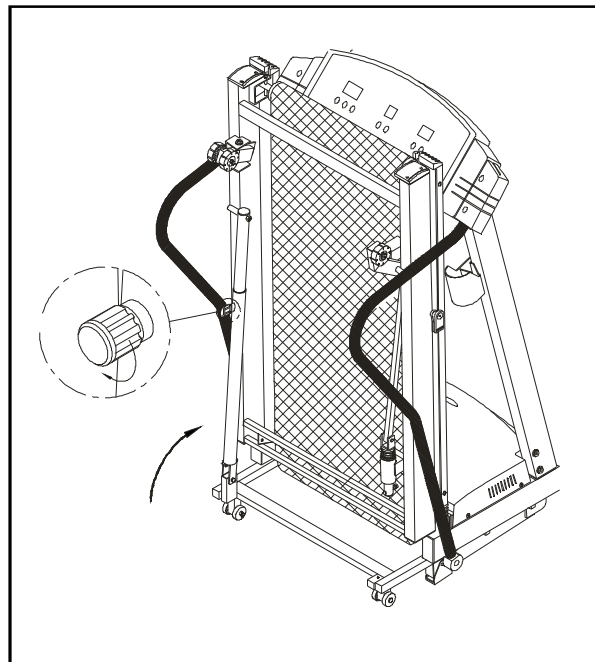

Fig.12

Note: Make sure the incline percentage is 0% before you fold the treadmill.

Unfolding the treadmill

CAUTION: Make sure the treadmill has come to a complete stop and the incline display shows "0" before folding.

Unfold the treadmill by turning the knob counterclockwise and then pull the knob to release.

Put down the treadmill very slowly until the treadmill is steady on the floor (see Fig. 13).

ITEM:1250

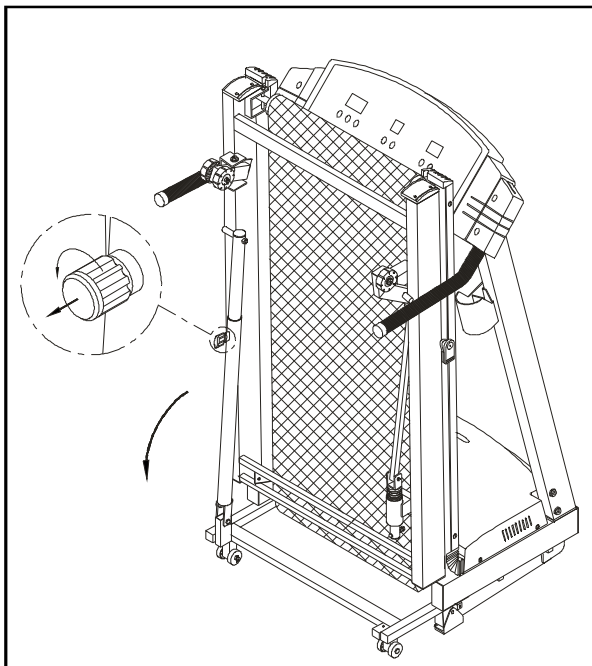

ITEM:1250L

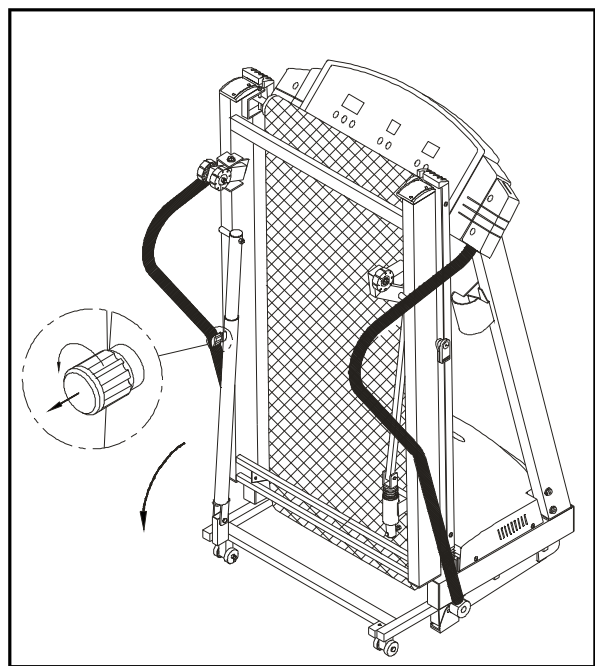



Fig.13

OPERATING INSTRUCTIONS

CAUTION: DO NOT STAND ON THE BELT WHEN STARTING.

Safety key



The safety key is required to operate the treadmill. The safety key should be used as an emergency stop by clipping the cord to your exercise clothing. Be sure to remove the safety key from your exercise clothing after you have finished your workout, and place it to the key  position for your convenience or store in a safe place to avoid use by children or persons unfamiliar with this treadmill.







Turn on the power switch located on the front of the treadmill. Place the safety key into the "SAFETY KEY" position on the electronics package in order for the unit to function.





UNDERSTANDING THE ELECTRONIC PACKAGE

Key functions:

SAFETY KEY: Turn on the POWER switch located on the front of the machine. Put the safety key on the "SAFETY KEY" position of the electronics package to operate the treadmill.

 (NOT IN USE) : After your workout, place the safety key on  (NOT IN USE) position for your convenience. Then turning the power switch off.

SPEED   : Use the speed   key to adjust your desired speed. The speed range for the treadmill is from 0.5-10 MPH (0.8-16 KPH). Press the speed  key to increase the speed and press the speed  key to decrease the speed.

INCLINE   : Use the INCLINE   key to raise or lower the treadmill. The incline range for the treadmill is from 0%-12%.



 **MODE:** When you place the safety key in its place, the electronics package will automatically access into MODE function. Press the mode key, and this will scroll you through the different modes. With each press of the MODE key, the display will alternately show TIME, DIST(Distance), CAL(Calories), SCAN or PULSE.

  key: These keys are used to choose the desired TIME or DISTANCE.

STOP/RESET: When you press the Stop/Reset button, and the treadmill will slowly come to a stop.

Press the Stop/Reset button once again, all display windows information will be cleared.

PROGRAM: The 1250 features a total of five (5) professionally designed workout programs. The programs control the elevation, while you control the speed of your workout. During the actual programs, you cannot change the elevation percentage, but you can change the speed of the treadmill.



Press the PROGRAM key to scroll through the 5 programs. The P1-P5 will be displayed in the central LED window, when you have chosen the Program you want, press the MODE  key to select the TIME or DIST. Use the TIME or DIST   keys to select your desired TIME or DIST (but not both), then press the SPEED keys to begin.

During these programs, you control the speed, and the unit will automatically switch between the elevation percentages, giving you the feeling of running on hills and level ground.

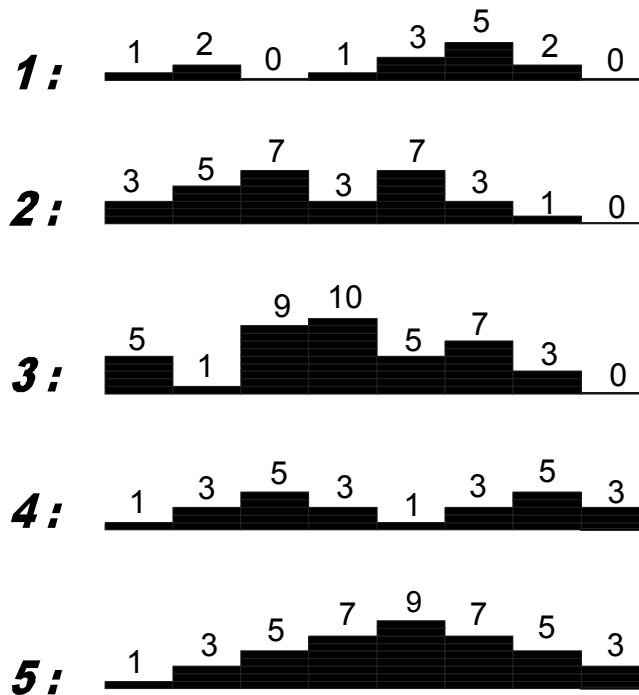

The course profile for each PROGRAM is as follows:



What each of the categories means:

TIME: The range available in TIME mode is 00:00-99:59 minutes. Use the MODE  key to select the time mode. When TIME LED is lit in the display, use the  keys to adjust the desired time.

The electronics package will BEEP for 10 seconds when your desired time is reached, then will start to count up if your workout continues.
Each press of the key change the time by 1 minute.

DIST: The distance of the treadmill will register goes from 0-99.99 miles or 0-999.9 kilometers. Use the MODE  key to select the DIST mode. When DIST LED is lit in the display, use the  keys to adjust the desired distance.

Each press of the key change the distance by 0.1 mile or 0.1 km.

The electronics package will BEEP for 10 seconds when your desired distance is reached, then will start to count up if your workout continues.

CAL: This readout gives you the amount of calories burned, the range of calories is from 0-999.9CAL.

SCAN: The SCAN will result in the display alternation between Modes readouts every 4 seconds.

PULSE: The treadmill is equipped a Polar receiver without transmitter. You need purchase a transmitter/Elastic strap to measure your heart rate during your workout.

Press the MODE  key to the pulse mode, the pulse indicator lit located on the electronics package. Optimal Polar heart rate distance should not exceed 0.6 meter in order to get the best result

RUNNING ON THE TREADMILL:

Now, you have become familiar with your treadmill's operation and are ready to exercise:

1. Plug the treadmill into a standard outlet. Turn on the power switch located on the front of the machine.
2. Straddle the belt with your feet on the right and left staging platforms. Place the safety key on the "SAFETY KEY" position of the electronics package to operate the treadmill.
3. Balancing one hand on the handrail. Adjust the SPEED  key until you reach 1.5-2.0 mile / 2.5-3.5 km, a comfortable walking speed. With both hands on the handrails, place one foot, then the other on the treadmill, and walk for a few minutes to get comfortable with your machine.
4. After you are walking in an easy, relaxed, and steady fashion, release your grip on the handrails, and let your arms swing freely and naturally.
5. When you feel comfortable walking, you may wish to jog. Hold the handrail with one hand, use the other hand to increase the speed.
6. Remember to hold the handrail when using the electronics package, or adjust the speed. Holding the handrail with one hand will help to maintain your balance, especially when slowing down or stopping. Also, remember to hold onto the handrail when dismounting.
7. It is best to do a cooldown before you bring the machine completely stop.

GUIDELINES FOR EXERCISE

How long should I exercise?

The duration of your exercise session is dependent on your fitness level. In general, it is recommended that you maintain your heart rate in the training zone for at least 10 minutes to realize an aerobic benefit. As your fitness level increases, you will be able to maintain your heart rate in the training zone for longer periods: usually between 20 and 30 minutes.

When first starting your workout, use the first several minutes to warm up, then slowly increase your workload to bring your heart rate into your specific training zone. At the end of your workout, gradually decrease your workload, then exercise lightly as a "cool down".

How often should I exercise?

Aerobic exercises, to achieve the greatest benefits, should be performed 3-5 times a week. It is important to allow sufficient time, at least 24 hours, for your body to recover after exercise.

MAINTAINING YOUR TREADMILL

Your treadmill relies on low friction for peak performance. The treadmill's low friction operation is dependent on keeping the unit as clean as possible. See "Cleaning the Treadmill" for more information.

Proper belt alignment is also important for proper operation of the treadmill. See "Adjusting the Running Belt" for more information.

Cleaning the treadmill

CAUTION: Turn off unit and disconnect AC cord before cleaning.

Regular cleaning is recommended to keep your treadmill running at peak performance.

Before your workout, use a dry cloth to clean the staging platform, exposed slider deck, and under the belt as far as you easily reach. This removes any dirt or dust which might enter the slider area and compromise the unit's running efficiency.

To clean the plastic parts, use a mild detergent and make sure the unit is completely dry before operating. On the running surface, use a soft nylon scrub brush. Do not use water to clean the belt or running surface, or to clean the electronics package. Should water, for some reason, get on the electronics package, immediately blow dry the electronics package.

It is recommended that you keep all liquids away from the unit during operation. Spillage of liquids onto or into the machine will void the warranty.

Adjusting the running belt

Your treadmill comes with a belt alignment gauge located on the left side of the motor cover (see Fig. 14). The edge of the running belt should be in the middle of the green portion of the gauge. If the belt edge is in the green area, the belt does not need adjusting. If the right edge is in the red portion, the belt needs adjusting immediately.

ITEM:1250

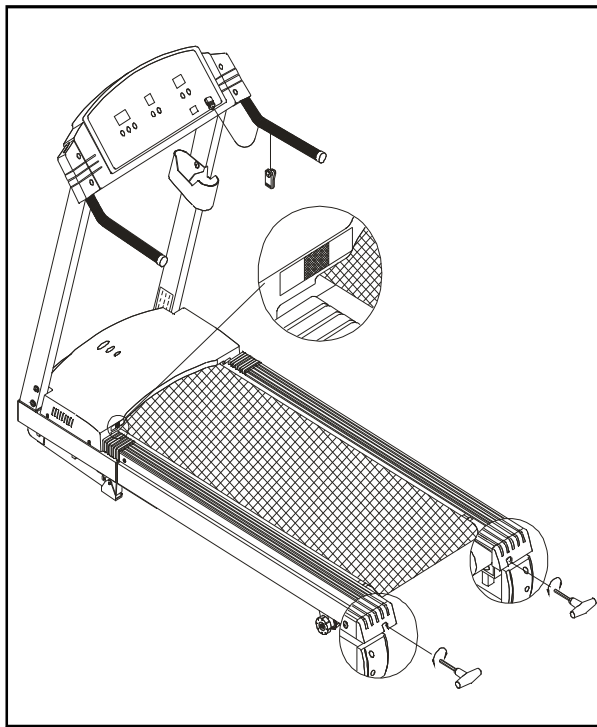

ITEM:1250L

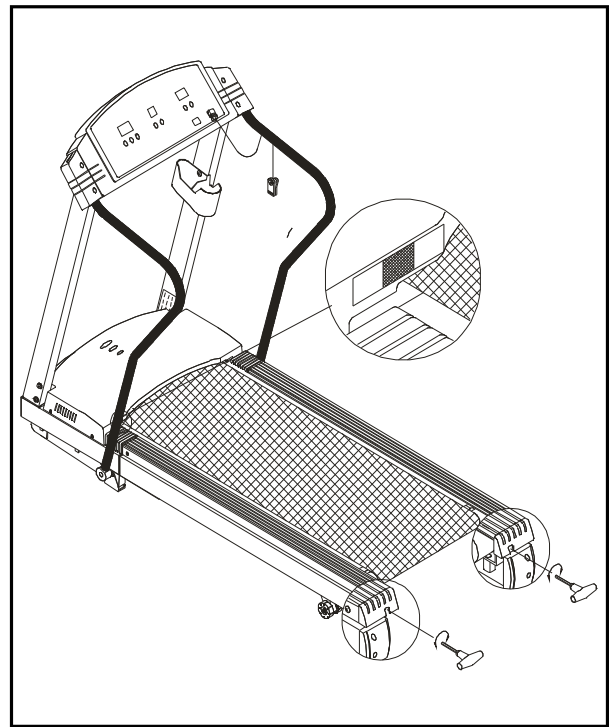

Fig.14

The belt is properly aligned at the factory. However, during shipping and handling or by use on an uneven surface, the belt may move off center. Therefore, it is important that you check the belt's alignment before using the treadmill.

The correct alignment of the running belt is critical for the smooth operation of the treadmill.

CAUTION: DO NOT ALLOW ANYONE TO WALK ON RUNNING BELT DURING THIS PROCEDURE.

Failure to realign the belt could result in tearing or fraying of the belt, which is not covered in the warranty. Please follow the adjustment procedure listed below :

1. Turn on the power switch located on the front of machine. Place the SAFETY KEY on the "SAFETY KEY" position.
2. Press the SPEED (key to increase the speed until the speed registers 2.0mph / 3.2kph on the digital display.
3. While the unit is running at 2 mph/3.2kph, determine where the belt is in relation to the belt alignment gauge.
4. Should your belt be in the wrong color range, follow the steps below to return the belt to the "safety zone":
5. If the belt is in the left red zone: Turn the left belt adjustment bolt located at the rear of the treadmill clockwise 1/4 turn at a time, using the hex Allen wrench. Then turn the right belt adjustment bolt counterclockwise 1/4 turn. Let the treadmill run 30 seconds, then check the position of the belt in the color gauge. If the belt still has not returned to the green safety zone, repeat with another 1/4 turn until the belt has returned to the middle of the green area. Do not turn adjusting bolt more than 1/4 turn at a time.

If the belt is on the edge of the green color, please adjust it so it is in the middle of the green color. You may turn the adjustment nut less than 1/4 turn at a time.

6. Conversely, if the belt is in the right red zone, turn the right belt adjustment nut clockwise 1/4 turn, then turn the left adjustment bolt counterclockwise 1/4 turn. Then let the treadmill run at least 30 seconds, check the position of the belt in the color gauge. If it still has not returned to the green safety zone, repeat with another 1/4 turn until the belt has return to the middle of the green area. Do not turn adjusting bolt more than 1/4 turn at a time.
7. When the belt is back in the green "safety zone", you can continue your regular use of the treadmill. Slowly increase the speed of the unit to 5.5 MPH (9 KPH), and let it run for at least 45 seconds.

Periodically monitor the position of the belt to ensure peak performance:

When you are using the treadmill, if you feel a pause in the belt with each foot plant the belt is too loose. Stop the machine, check the belt tension, grab the running belt off the deck in the middle (see Fig.15 & 15-1). There should be about 30 m/m (1 1/8") or 3 kgs of "give" in the belt. If there is too much (see Fig. 15-2), then adjust both rear roller bolts clockwise 1/2 turn at a time (see Fig.15-3).

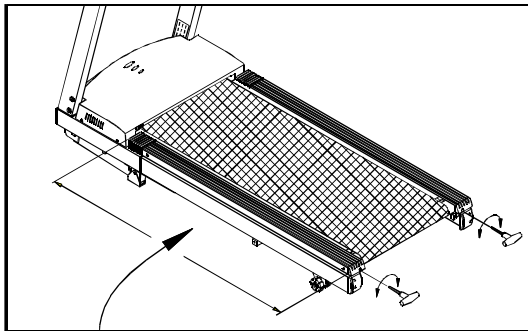

Fig.15

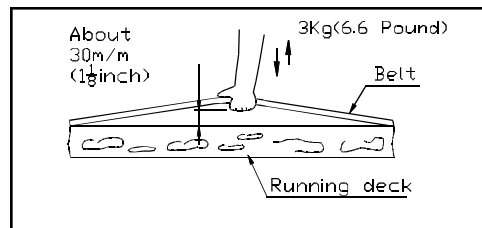

Fig.15-2

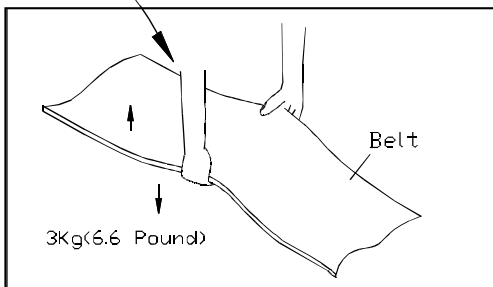

Fig.15-1

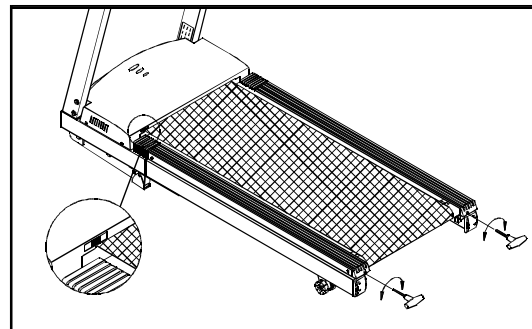

Fig.15-3

Then, try the belt tension again, if more adjusting is required, give both adjusting bolts another slight turn. Do not adjust over 2 fullturns.

Conversely, if the "give" in the belt is too tight, adjust both rear rooler bolts counterclockwise 1/2 turn at a time (see Fig. 15-3)

CAUTION: To avoid injury, special care must be taken when adjusting the running belt. Turn off the treadmill while adjusting or working near the rear rollers. Remove any loose clothing or shoe laces and tie back your hair. Be very careful to keep your fingers or any other objects clear of the belt and rollers.

The treadmill is designed to carry specific weights at specific speeds. The treadmill will not stop immediately if any object becomes caught in the belt or rollers.

Over tightening of the belt causes damage and premature failure of the precision bearings in the front and rear rollers.

TROUBLE SHOOTING:

CAUTION: SHUT OFF UNIT AND DISCONNECT AC CORD BEFORE MAKING ANY REPAIRS OR MODIFICATIONS.

"ERR" messages

Note: If the electronic display shows "ERR 1, ERR 3, ERR 6 or ERR 7", please turn off the POWER switch on the front of the machine. Allow the unit rest for 5 seconds, then turn on the power switch begin operation again. Should the electronics package display "ERR" again, please refer to the following section for more information. OR, please contact your dealer for further instructions.

ERR 1- The optical switch mounted on the motor is not receiving the signal reflected from the tachometer wheel. Please contact your dealer.

ERR 3- Treadmill speed doesn't match the setting. Contact your local dealer for assistance.

ERR 6- The unit's incline system is not responding, please replace the 0.5A (200-240V) or 1A (100-120V) fuse located underneath the treadmill, make sure your area standard voltage prior to replacement.

The incline system fuse holder is located under the frame at the front of the machine (see Fig. 16).

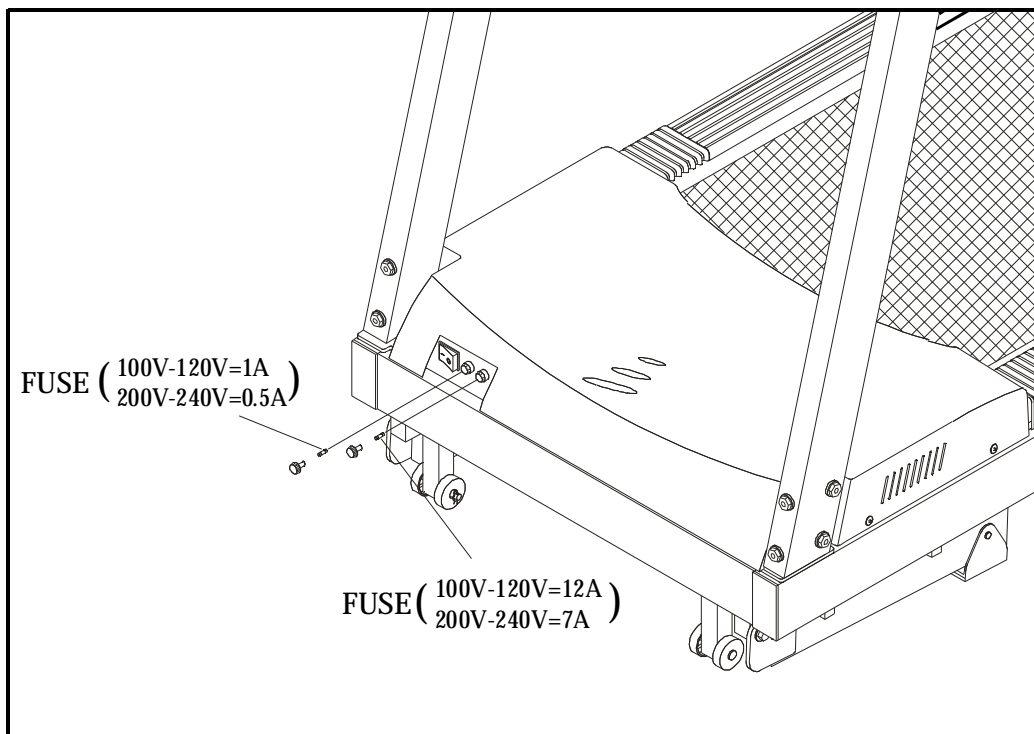

Fig.16

To remove the fuse, push on the fuse holder and then turn the holder counterclockwise and the fuse holder with fuse will protrude.

Remove the damage fuse and insert a new fuse, push the fuse and holder in, turning clockwise to secure it.

If the unit still refuse to respond, please contact your dealer for more information.

ERR 7- Once you turn on the machine, the computer display shown the ERR 7. The computer receiving the signal reflected from VR incorrectly, that means the wires disconnected.

Make sure the 16 pin cable connector inside the right front post plug into its socket at the base of the treadmill is connected securely, please refer to Fig. 3.

If, after performing the above steps, the display still shows ERR 7, please contact your dealer for further information.

Blank display

1. If you turn on the POWER switch and there is no light:
 - a. Check if the power cord is plugged securely into the wall socket.
 - b. Check that the power switch on the front of the unit is in the "ON" position. The power switch should be lit.
 - c. If the power switch is no light, replace the fuse. Please refer to the ELECTRONICS PACKAGE AND MOTOR FUSE FAILURE section for more information.
 - d. If there is still no display after completing the above steps, please contact your dealer for more information.

2. The power switch is lit, but no words appear on the display:
 - a. Make sure the cable connectors inside the right lift post at the base of the treadmill is firmly in its sockets. Please refer to the Fig. 2.
 - b. If the display is no words, then the fuse on the drive board need to be replaced, please check with your dealer for further information.

Electronics package and motor fuse failure

If you turn on the POWER switch and there is no light, and nothing displays on the electronics package, then the fuse must be replaced.

CAUTION: MAKE SURE THE TREADMILL PLUG ALREADY REMOVE FROM OUTLET BEFORE REPLACE THE FUSE.

The fuse holder 12 amp (100V-120V) / 7 amp (200V-240 V) for electronics package and motor are located under the frame at the front of the machine. Please make sure your area standard voltage prior to replacement and follow the steps as shown in Fig. 17-1 to 17-3.

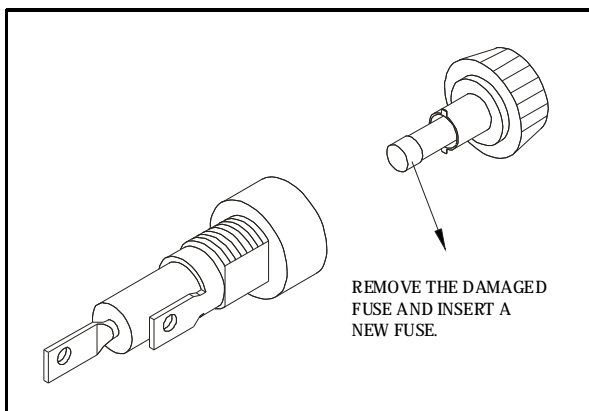

Fig.17-1

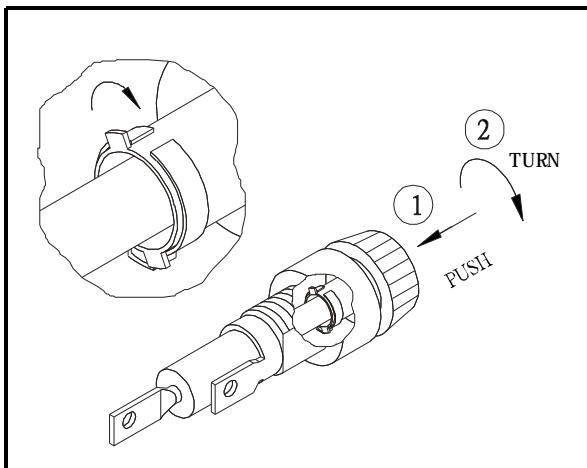

Fig.17-2

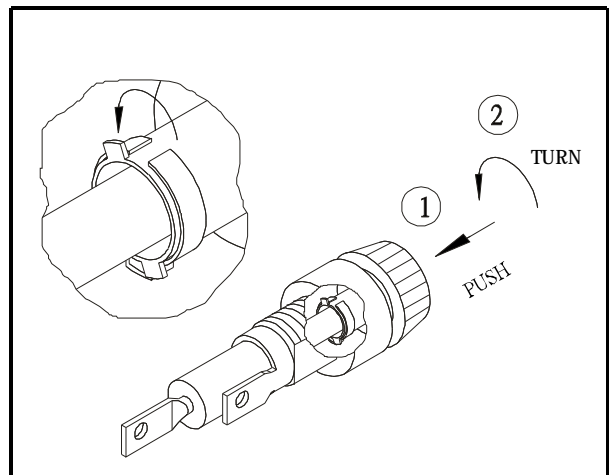

Fig.17-3

To remove the fuse for the electronics package and motor, push on the fuse holder and then turn the holder counterclockwise and the fuse holder with fuse will protrude. Remove the damaged fuse and insert a new fuse, pushing the fuse and holder in, then turning clockwise to secure the fuse holder.

If the unit's electronics package refuses to respond after changing the fuse, please contact your dealer for more information.

Fuse Failure For Incline System

Should the incline system refuse to respond, but there is power to the electronics package and it remains operable, please replace the incline system fuse.

The 1 amp (100V-120V) / 0.5 amp (200V-240 V) fuse is for the Incline system. To remove the incline system fuse, push on the fuse holder and then turn the holder counterclockwise and the fuse holder with fuse will protrude. Remove the damaged fuse and insert a new fuse, pushing the fuse and holder in, then turning clockwise to secure the fuse holder (see Fig. 17-1 ~ 17-3).

If the incline system refuses to respond after changing the fuse, please contact your dealer for more information.

Fuse failure for drive board

NOTE: If you are not a technician or do not have expert knowledge of this machine. Please do not attempt to replace it.

If there is nothing displays on the electronics package, and the POWER SWITCH located on the front of the treadmill if lit, then the fuse is damaged on the drive board and must be replaced.

The fuse holder 0.5 amp for the drive board is located on the frame at the front of the treadmill (see Fig. 18).

ITEM:1250

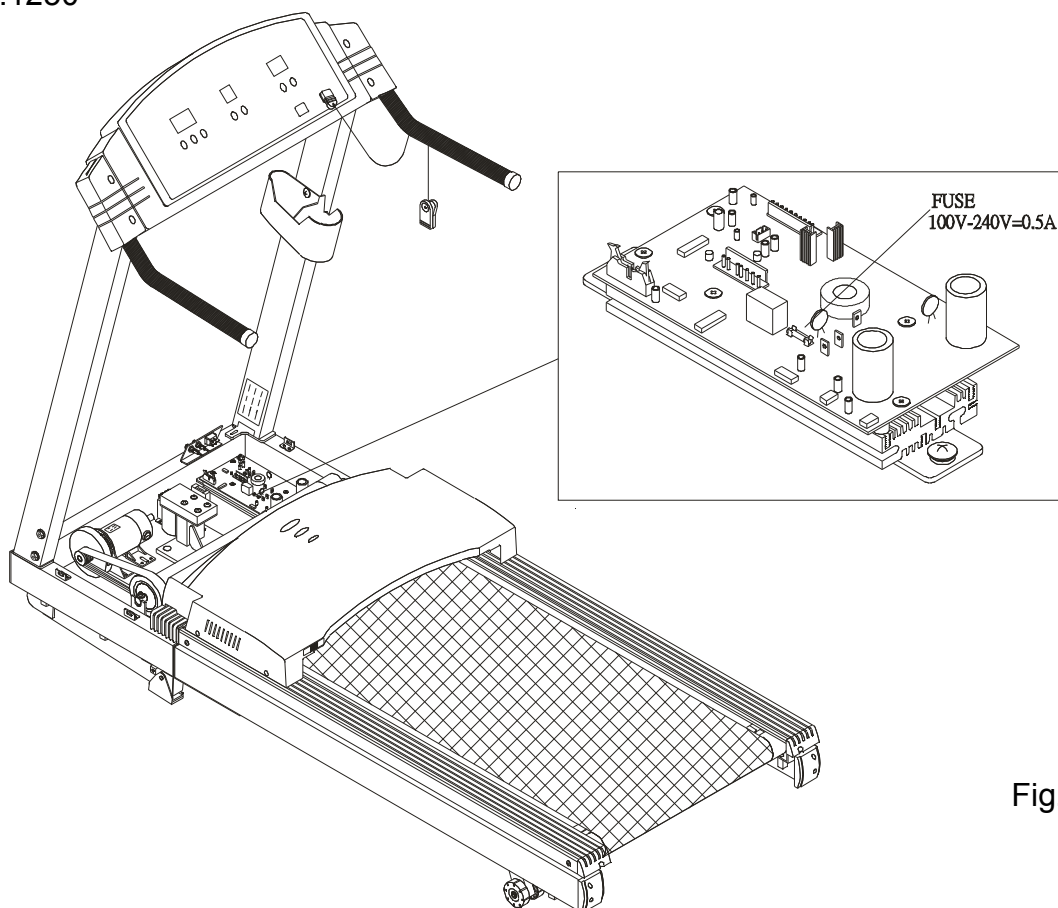
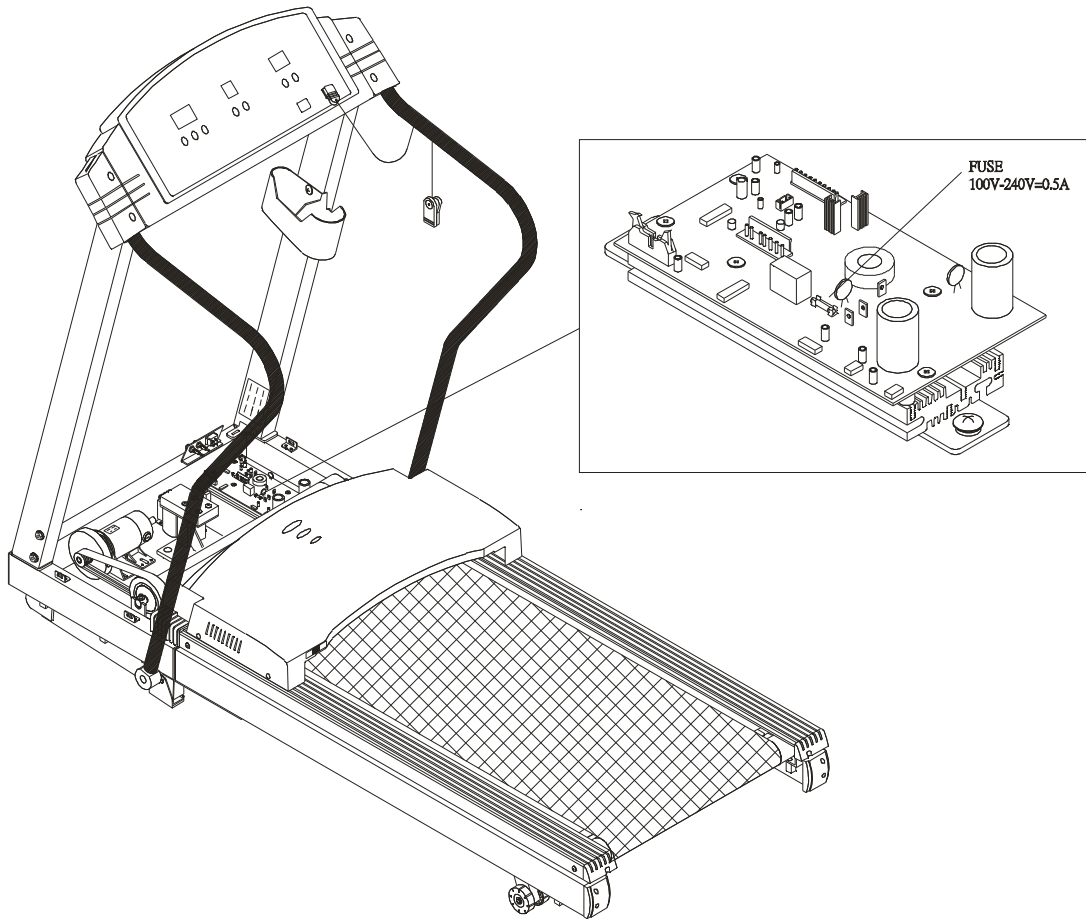
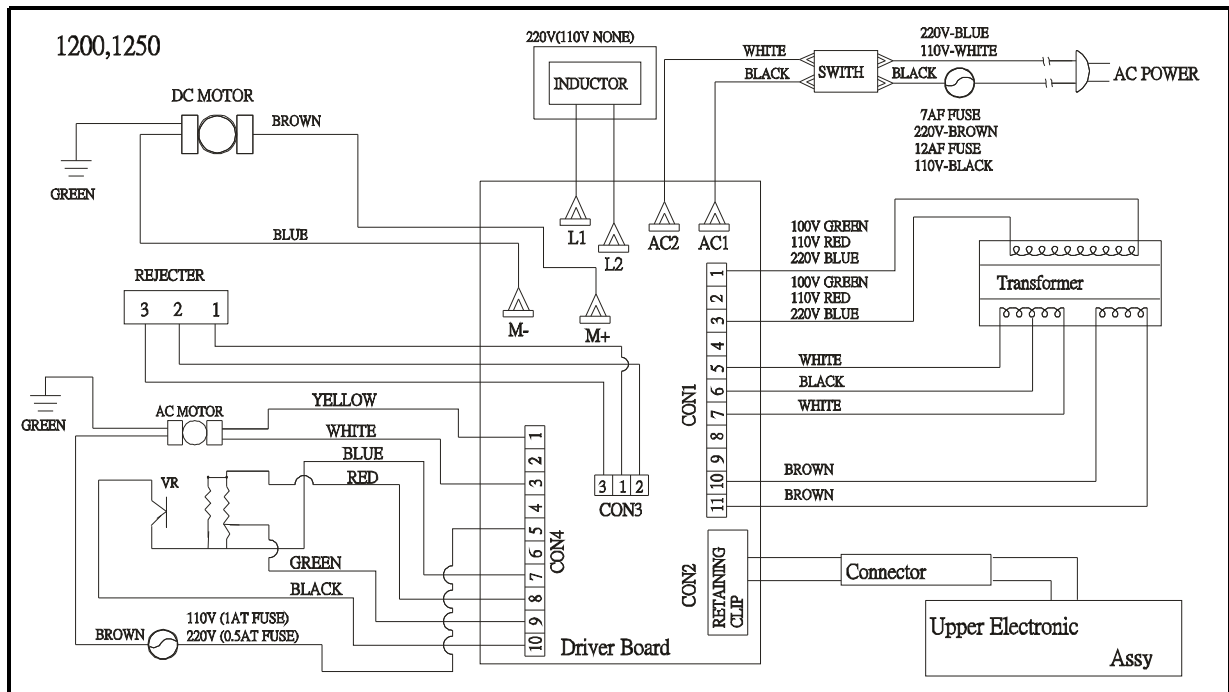

Fig.18

ITEM:1250L



Wiring Schematic:



ΜΕΚΜΑ Α.Ε.
ΚΑΣΤΑΜΟΝΗΣ 148 ΑΛΣΟΥΠΟΛΗ
ΤΗΛ. 2758228 - 2710675 FAX 2774798

Your Authorized Distributor