



De'Longhi S.p.A.

Via Seitz, 47
31100 TREVISO
Italy

www.delonghi.com



T130ARC

AIR CONDITIONER

CLIMATISATEUR

CLIMATIZADOR

CONDIZIONATORE



- Use this appliance only as described in this instruction manual. As with all electrical equipment, whilst the instructions aim to cover as many eventualities as possible, caution and common sense should be applied when operating and installing this appliance.
- This appliance is designed to air condition and heat the home and must not be used for other purposes.
- It is dangerous to modify or alter the characteristics of the appliance in any way.
- The appliance must be installed in conformity with national legislation regulating electrical equipment and installations.
- If the appliance requires repair, contact a Service Centre authorised by the manufacturer only. Repairs carried out by unauthorised personnel may be dangerous.
- This appliance must be used exclusively by adults.
- Never allow the appliance to be used by people (including children) with psychological, physical or sensory impairments or with insufficient experience and knowledge, unless closely supervised and instructed by someone responsible for their safety. Young children should be supervised to ensure that they do not play with the appliance.
- The appliance must be connected to an efficient earth system. Have your electrical circuit checked by a qualified electrician.
- Do not use extension cables.
- Before cleaning or maintenance, always unplug the appliance from the mains socket.
- Never unplug the appliance by pulling on the power cable.
- Do not install the appliance in rooms containing gas, oil or sulphur. Do not install near sources of heat.
- Keep the appliance at least 50 cm away from flammable substances (alcohol etc) or pressurised containers (eg aerosol cans).
- Do not rest heavy or hot objects on top of the appliance.
- Clean the air filter at least once a week.
- Avoid using heating appliances near the air conditioner.
- Always transport the appliance upright or resting on one side. Before moving the appliance, empty the internal circuit completely of water. After moving the appliance, wait at least 1 hour before starting it
- When putting the appliance away, do not cover with plastic bags.
- The materials used for packaging can be recycled. You are therefore recommended to dispose of them in special differentiated waste collection containers.
- At the end of its working life, consign the appliance to a specialist collection centre.
- If the power cable is damaged, it must be replaced by the manufacturer or an authorised technical service centre in order to avoid all risk.
- Before transporting the appliance, completely empty the internal circuit of water by pressing the **MODE** and **FAN** buttons simultaneously for a few seconds without removing the tank. Then empty the tank

ELECTRICAL CONNECTIONS

Before plugging the appliance into the mains socket, check that:

- the mains power supply corresponds to the value indicated on the rating plate on the back of the appliance;
- the power socket and electrical circuit are adequate for the appliance.
- the mains socket matches the plug. If this is not the case, have the plug replaced;
- the mains socket is adequately earthed.

Failure to follow these important safety instructions absolves the manufacturer of all liability.

WHAT IS THE PINGUINO

During the summer, you feel comfortable at a temperature of between 24 and 27° C with a relative humidity of about 50%.

An air conditioner removes excess moisture and heat from the room where it is located. Compared with installed models, portable air conditioners have the advantage that they can be moved from one room to another in the home or be transported from one building to another.

Hot air from the room is passed through a coil cooled by refrigerant gas. Excess heat and moisture are removed before the air is re-emitted into the room.

In single unit models, a small part of this air is used to cool the refrigerant gas and then, when hot and damp, is discharged outside.

In the spring and autumn, the appliance can also be used to heat.

The efficient heat pump system provides a high heating capacity with low energy consumption.

All Pinguino models can also be used in fan-only mode.

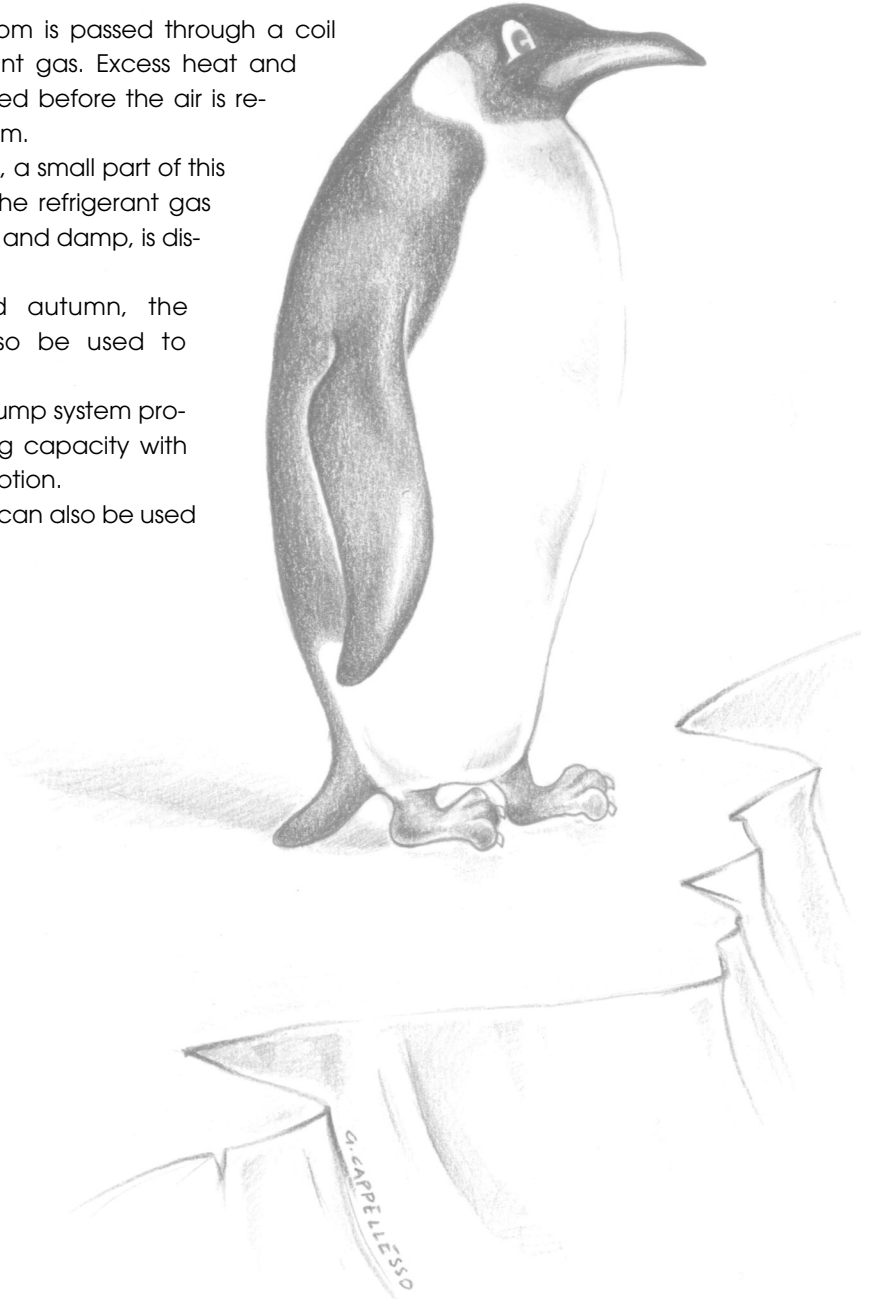

DESCRIPTION

- A** air outlet grille
- B** control panel
- C** castors
- D** handles
- E** air intake grille with dust filter
- F** air exhaust hose housing
- G** air intake grille
- H** continuous condensate drain connection
- I** condensate tank
- J** power cable
- K** flange cap
- L** air exhaust hose
- M** window outlet
- N** suckers
- O** castor locks
- P** continuous drain hose with coupling
- Q** remote control
- R** 3M air purifying filter
- S** silver ion filter (certain models only)
- T** adjustable bar

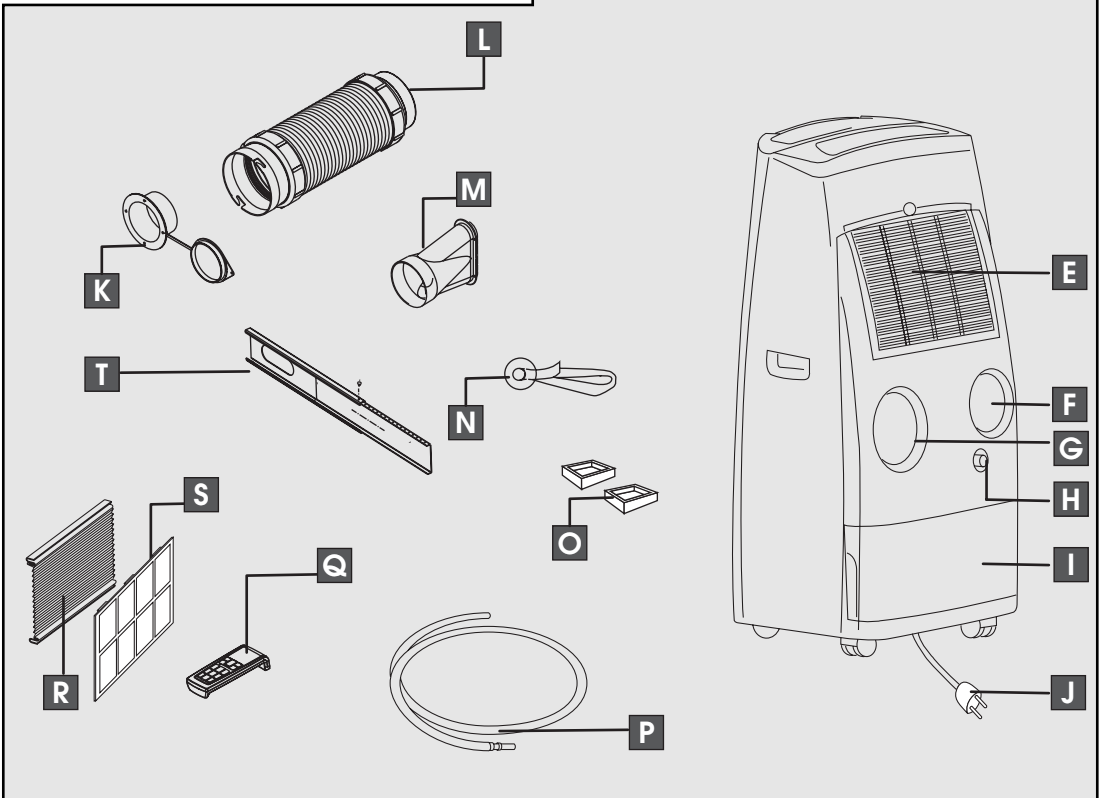
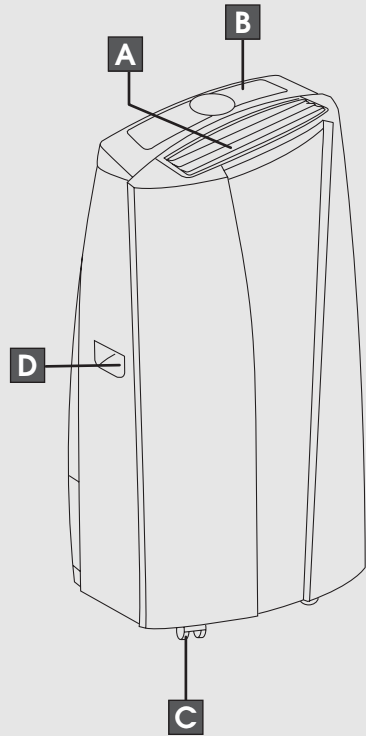

PREPARING FOR USE

The instructions below will enable you to prepare your air conditioner for operation as efficiently as possible.

Before use, make sure the air intake and outlet grilles are unobstructed.

AIR-CONDITIONING WITHOUT INSTALLATION

Just a few simple steps and your comfort is ensured with your appliance:

- Fit the air exhaust hose in the housing at the back of the appliance (fig. 1).
- Fit the window outlet to the end of the hose.
- Place the air conditioner near a window or French window.
- Adjust the length of the hose to reach the window.
- Make sure the air exhaust hose is unobstructed.
- Open the window or French window slightly and position the outlet (fig. 2).
- If you have a double window, use the sucker provided to hold the two parts of the window together (fig. 3).

You can also use the "adjustable bar" accessory.

- Fit the window outlet in the housing in the bar (fig. 4). Position the bar on the windowsill and extend it for the complete width of the window. The required length can be blocked using the pin provided, then lower the blind or window (fig. 5).
 - Fit the air exhaust hose in the housing at the back of the appliance (fig. 1).
 - Place the air conditioner near a window and connect the end of the hose as shown in figure 6.

Keep the air hose as short and free of curves as possible to avoid bottlenecks.

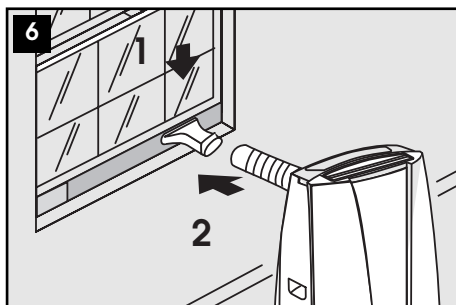
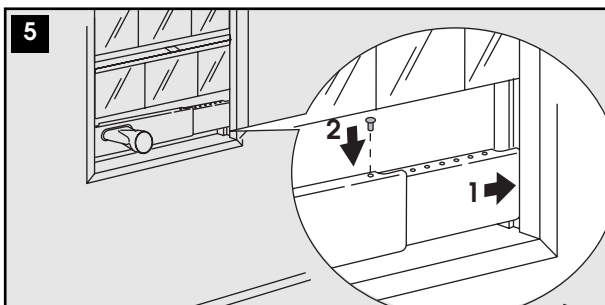
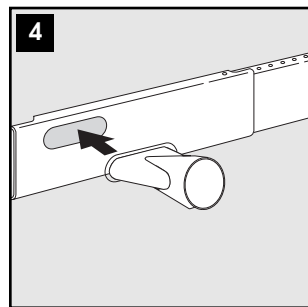
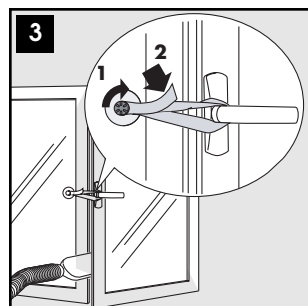
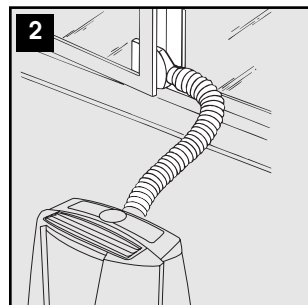
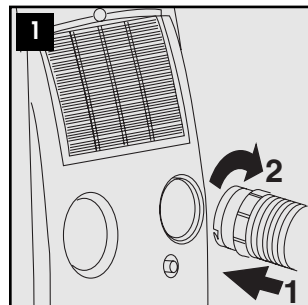

AIR-CONDITIONING WITH INSTALLATION

If required, your appliance can also be installed semi-permanently (Fig. 7).

Proceed as follows:

- Drill a 106 mm dia. hole respecting the heights shown in fig. 8.

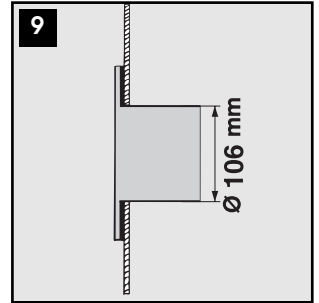
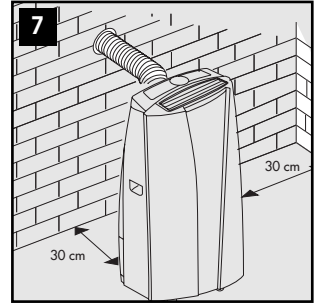
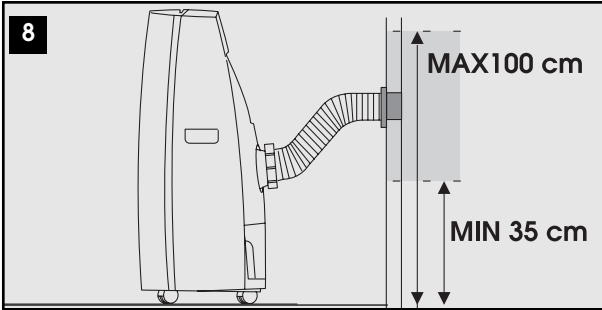

in the window pane

- Fit the flange accessory provided in the hole following the indications in figs. 9, 10 and 11.
- Fit the hose in the housing at the back of the appliance (fig. 1).
- Fit the end of the hose to the flange as shown in fig. 8. When the hose is not fitted, the hole can be closed with the flange cap.

Keep the air hose as short and free of curves as possible to avoid bottlenecks.

- ✓ When installing the air conditioner semi-permanently, you should leave a door slightly open (as little as 1 cm) to guarantee correct ventilation.
- ✓ When using the appliance to heat a room with a high level of humidity, condensate may appear on the outside of the air exhaust hose. To avoid this, you can cover the hose with insulation.

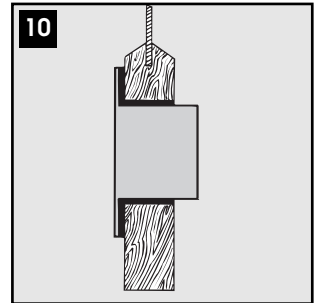

in the wooden kickboard of a French window

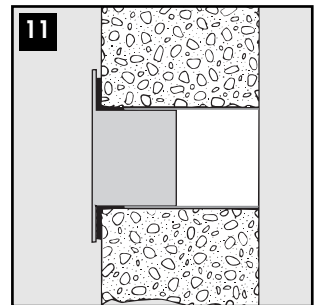

in the wall: you are recommended to insulate the section of wall using suitable insulation.

DESCRIPTION OF CONTROL PANEL

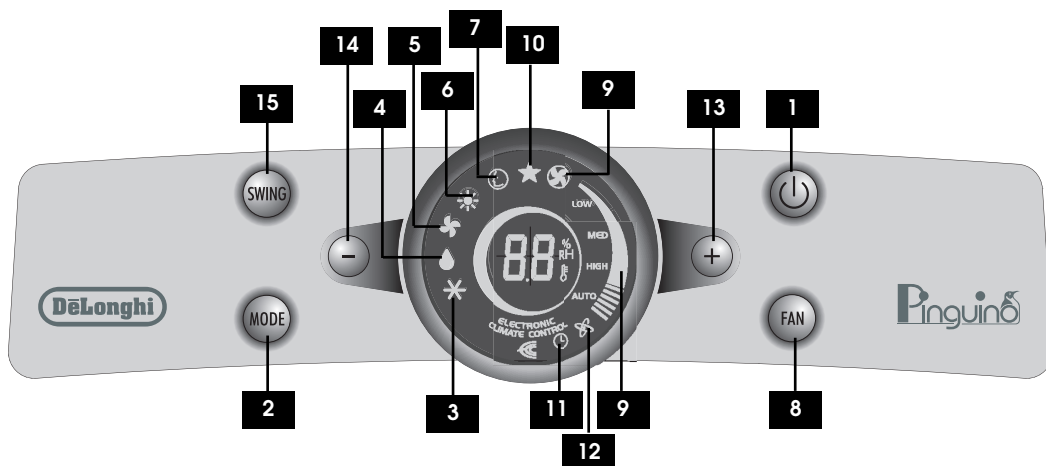

- | | |
|--|--|
| <p>1 ON/Standby button (on/off)</p> <p>2 MODE button (selects the modes): Air conditioning, dehumidifying, air purifying/fan, heating, Smart.</p> <p>3 Air conditioning symbol</p> <p>4 Dehumidifying symbol</p> <p>5 Air purifying/fan symbol</p> <p>6 Heating symbol</p> <p>7 Smart symbol</p> <p>8 Fan speed button: Low - Med - High - Auto.</p> | <p>9 Speed indicator</p> <p>10 SLEEP symbol</p> <p>11 Timer symbol</p> <p>12 Ioniser symbol (certain models only)</p> <p>13 Increase button (+)</p> <p>14 Decrease button (-)</p> <p>15 SWING button (movement of the grille flaps)</p> |
|--|--|

OPERATING FROM THE CONTROL

The control panel enables you to manage all the main functions of the appliance, but to fully exploit its potential, you must use the remote control unit.

⏻ TURNING THE APPLIANCE ON (1)

- Plug into the mains socket. Two lines appear on the display indicating that the appliance is in standby (fig. 12).
- Press the ⏻ button until the appliance comes on. The last function active when it was turned off will appear. When the appliance comes on, the last function active when it was turned off will appear.

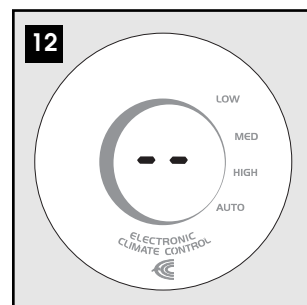

- ✓ Never turn the air conditioner off by unplugging from the mains. Always press the ⏻ button, then wait for a few minutes before unplugging. This allows the appliance to perform a cycle of checks to verify operation.



AIR CONDITIONING MODE (FIG. 13)

Ideal for hot muggy weather when you need to cool and dehumidify the room.

To set this mode correctly:

- Press the **MODE** button a number of times until the air-conditioning symbol appears (3).
- Select the target temperature by pressing the **+** or **-** button until the corresponding value is displayed.
- Select the required fan speed by pressing the **FAN** button.

Four speeds are available:



High speed: to achieve the target temperature as rapidly as possible

Medium speed: reduces noise levels but still maintains a good level of comfort

Low speed: for silent operation

AUTOFAN: the appliance automatically selects the most suitable fan speed in relation to the temperature set on the digital display.

The most suitable temperature for the room during the summer varies from 24 to 27°C. You are recommended, however, not to set a temperature much below the outdoor temperature.

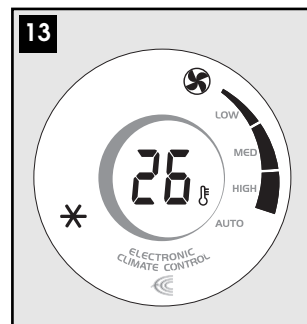

MODALITÀ DEUMIDIFICAZIONE (FIG. 14)

Ideal to reduce room humidity (spring and autumn, damp rooms, rainy periods, etc).

Place the appliance in the room without fitting the air exhaust hose.

To set this mode correctly:

- Press the **MODE** button a number of times until the dehumidifying symbol (4) appears, then press the **+** or **-** button until the required humidity level is displayed.

At the same time, the Auto fan light comes on as the appliance automatically selects the most appropriate speed.

Water is removed from the air and collected in the tank at the back of the air conditioner.

When the tank is full, the appliance shuts down and *Fl* (full tank) appears on the display. The tank must be extracted and emptied (fig. 15). When the tank has been emptied, the appliance starts up again.

The accessory continuous drain hose enables the condensate produced to be eliminated without requiring the tank to be emptied periodically. Fit the hose with the rapid coupling as shown in fig. 16.

NB: In order for the continuous drain function to operate correctly, make sure the accessory is fully connected to the coupling. To release, press the coupling flange.

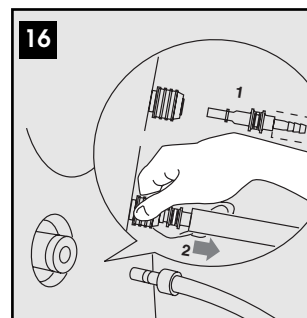
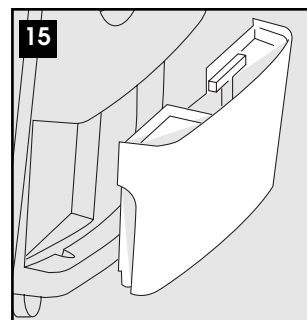
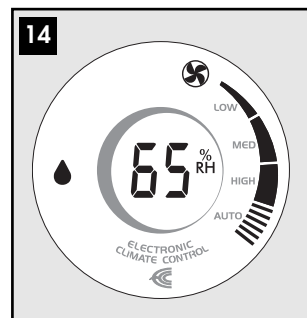



AIR PURIFYING/FAN MODE (FIG. 17)

When using the appliance in this mode, the air exhaust hose does not need to be attached.

To set this mode correctly:

- Press the **MODE** button a number of times until the fan symbol appears (5).
- Select the required fan speed by pressing the **FAN** button. Three speeds are available:



High speed: for maximum fan power

Medium speed: reduces noise levels but still maintains a good level of comfort

Low speed: for silent operation

In this mode, AUTO speed cannot be selected.

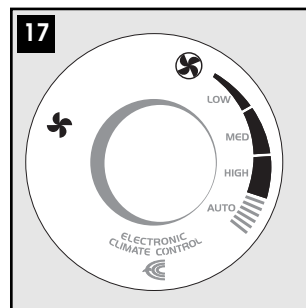

HEATING MODE (FIG. 18)

To set this function correctly:

- Press the **MODE** button a number of times until the heating symbol (6) appears.
- Select the required temperature by pressing the + or - button until the corresponding value is displayed.
- In heating mode, the fan speed is selected automatically by the appliance.

Water is removed from the air and collected in the tank at the back of the air conditioner.

When the tank is full, the appliance shuts down and **FL** (full tank) appears on the display. The tank must be extracted and emptied (fig. 15). **When the tank has been emptied, the appliance starts up again.** The continuous drain hose accessory enables the condensate produced to be eliminated without requiring the tank to be emptied periodically. To use the continuous drain function, fit the hose with the rapid coupling as shown in fig. 16.

N.B.: - When operating in very cold rooms, the appliance defrosts automatically, momentarily interrupting normal operation. "LT" appears on the display. During this operation, it is normal for the noise made by the appliance to change.

- In this mode, the fan may operate for short periods, even though the set temperature has already been reached.

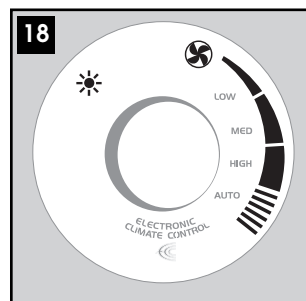

SMART MODE (FIG. 19)

In this mode, the appliance automatically sets the operating mode (air conditioning, fan, heating), the most suitable temperature for optimum well-being and the fan speed.

To set this mode:

- Press the **MODE** button a number of times until the **SMART** symbol appears.

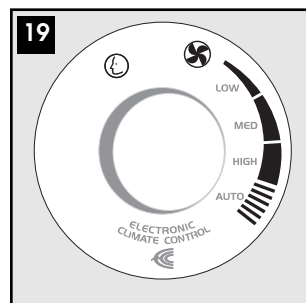

SWING BUTTON (15)

Moves the grille flaps to distribute the cool air uniformly in the room.

- When the **SWING** button is pressed once, the flaps begin moving alternately forwards and backwards. Press the SWING button again to stop the flaps in their current position. Pressing the button again will restart the flaps moving forwards and backwards.
- When the appliance is turned off, the flaps will close irrespective of their position.

DESCRIPTION OF THE REMOTE CONTROL

- 1 Air conditioning symbol
- 2 Dehumidifying symbol
- 3 Fan symbol
- 4 Heating symbol
- 5 Smart symbol
- 6 Signal transmission
- 7 Selected temperature scale indicator
- 8 Relative humidity indicator
- 9 SLEEP symbol
- 10 AUTOFAN indicator
- 11 Fan speed indicator
- 12 Clock
- 13 Timer ON symbol
- 14 Timer OFF symbol
- 15 MODE button (selects the modes)
- 16 ON/Stand-by button
- 17 FAN button
- 18 Increase (+) and decrease (-) temperature button
- 19 Reset button (resets the factory default settings)
- 20 Timer ON button
- 21 SET button
- 22 Timer OFF button
- 23 SWING button
- 24 SLEEP button
- 25 °C or °F selection button

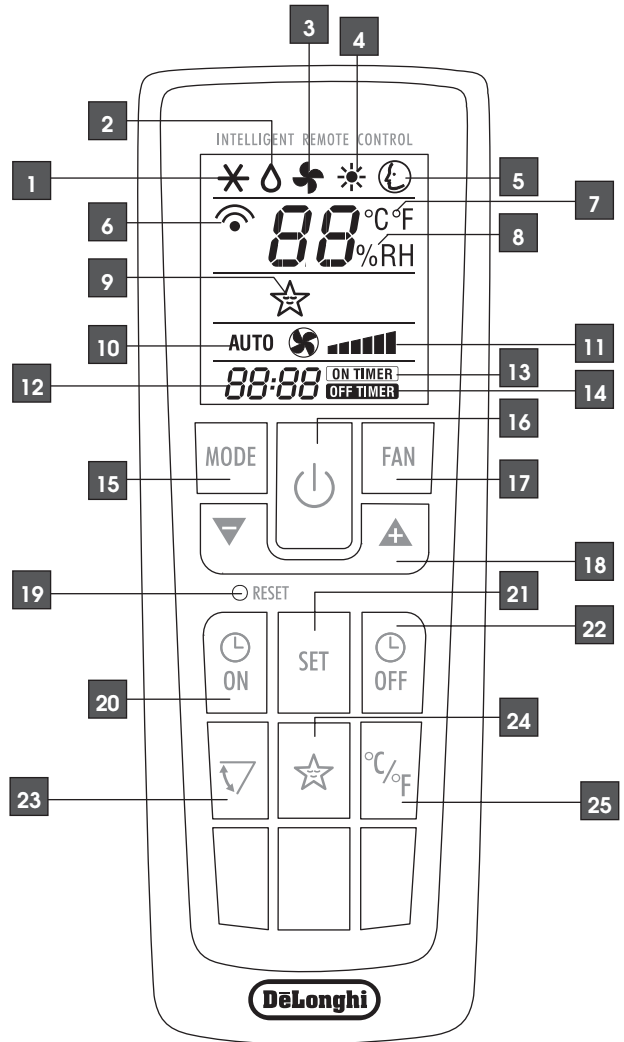

USING THE REMOTE CONTROL

- ✓ Point the remote control at the receiver on the appliance. The remote control must be no more than 7 metres away from the appliance (without obstacles between the remote control and the receiver).
- ✓ The remote control must be handled with **extreme care**. Do not drop it or expose it to direct sunlight or sources of heat.

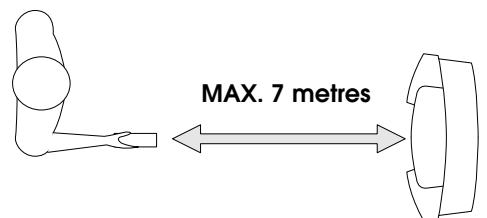

INSERTING OR REPLACING THE BATTERIES

- Remove the cover on the rear of the remote control (fig. 20);
 - Insert two R03 "AAA" 1.5V batteries in the correct position (see instructions inside the battery compartment);
 - Replace the cover.
- ✓ If the remote control unit is replaced or disposed of, the batteries must be removed and discarded in accordance with current legislation as they are harmful to the environment.

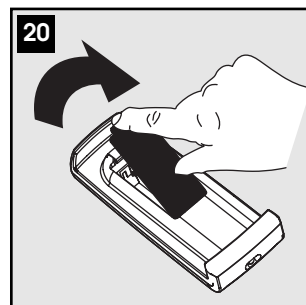

SETTING THE TIME

After having inserted the batteries, the clock on the display flashes until the time is set. Proceed as follows.

- Press the **+** or **-** button until the correct time is reached. Hold the button down to run rapidly through first the minutes, then the tens of minutes and then the hours.
- Once the correct time has been reached, press the **SET** button to confirm.

If you need to change the time later, press the **SET** button, then set as described above.

To cancel the settings programmed on the remote control and restore the original settings, press the **RESET** button lightly with the point of a pencil or pen.

USING THE REMOTE CONTROL UNIT

The **ON/Stand-by**, **MODE**, **FAN +** and **-** buttons correspond to the equivalent buttons on the control panel.

ON/STAND-BY BUTTON: Turns the appliance on and off.

MODE BUTTON: Selects modes: AIR CONDITIONING, DEHUMIDIFYING, AIR PURIFYING, FAN, HEATING, SMART.

FAN BUTTON: selects fan speed (High, Medium, Low, Auto).

+ and - BUTTON: increase and decrease

To use these buttons see the section "Operating from the control panel".

The following section describes the additional functions corresponding to the controls on the bottom part of the remote control.

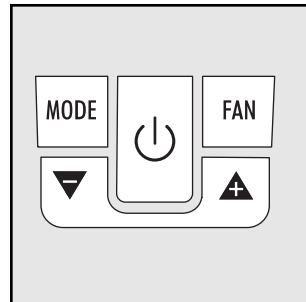

SELECTING THE TEMPERATURE SCALE (FIG. 21)

Press the $\frac{^{\circ}\text{C}}{^{\circ}\text{F}}$ button to switch the temperature display from $^{\circ}\text{C}$ to $^{\circ}\text{F}$ and vice versa.

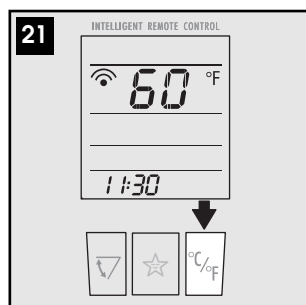



SLEEP FUNCTION (FIG. 22)

This function is useful for the night as it gradually reduces operation of the appliance.

To set this function correctly:

- Press the  button.

The SLEEP function maintains the room at optimum temperature without excessive fluctuations in either temperature or humidity and with silent operation.

In air conditioning or dehumidifying, fan speed is always at minimum, while room temperature and humidity vary gradually to ensure the most comfortable conditions.

During air conditioning, the temperature increases by 1°C after 60 minutes and a further degree after 2 hours.

In dehumidifying mode, the dehumidifying capacity is partially reduced every hour, two times.

In heating mode, the temperature drops by 1°C every hour, three times.

In **SMART** mode, the temperature varies according to the operating mode chosen automatically by the appliance from air conditioning, fan and heating.

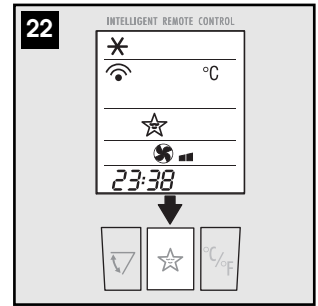

SWING FUNCTION (FIG. 23)

The SWING function moves the grille flaps to distribute the air uniformly in the room.

When the **SWING** button is pressed and the flaps have begun moving alternately forwards and backwards, pressing the button again will lock the flaps in their current position.

Pressing the button again will restart the flaps moving forwards and backwards.



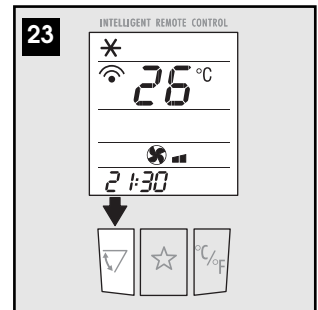

When the appliance is turned off, the flaps will close irrespective of their position.



PROGRAMMING THE TIMER





The timer can be programmed to start up and shut down to fit in with your needs.

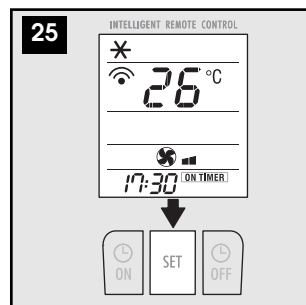
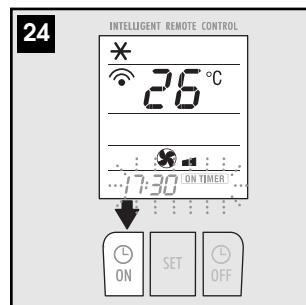

Programming start up

- Press the  ON button. The start-up time and message "ON TIMER" flash on the remote control display (fig. 24).
- Press the  or  buttons to set the time you want the appliance to start up.
- When that time is reached, press the **SET** button to confirm (fig. 25). The message "ON TIMER" appears on the remote control display and the  symbol is displayed on the appliance to indicate that the timer is active.



Programming shutdown

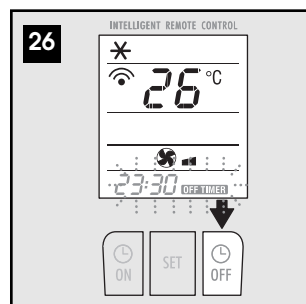
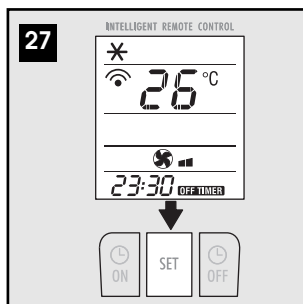

- Press the  OFF button. The shutdown time and the message "OFF TIMER" flash on the remote control display (fig. 26).
- Press the  or  buttons to set the time you want the appliance to shut down.
- When that time is reached, press the **SET** button to confirm (fig. 27). The message "OFF TIMER" appears on the remote control display and the  symbol is displayed on the appliance to indicate that the timer is active.

To deactivate the timer, press the relative timer button ( ON or  OFF) twice.

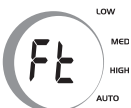
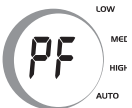

SELF-DIAGNOSIS

The appliance has a self diagnosis system to identify a number of malfunctions. Error messages are displayed on the appliance display.

IF ...	IS DISPLAYED, WHAT SHOULD I DO?	IF ...	IS DISPLAYED, WHAT SHOULD I DO?
 LOW TEMPERATURE (frost prevention)	The appliance is fitted with a frost protection device to avoid excessive formation of ice. The appliance starts up again automatically when the defrosting process is completed.	 FULL TANK (tanica piena)	Empty the tank on the back of the appliance and replace it correctly. The continuous drain hose is not connected correctly or is obstructed and the air conditioner is draining into the tank. NB: in dehumidifying mode, it is normal for this message to appear when the continuous drain hose is not connected.
 PROBE FAILURE (sensor damaged)	If this is displayed, contact your local authorised service centre.	 FAILURE 1 (pump failure)	If this is displayed, contact your local authorised service centre.

TIPS FOR CORRECT USE

To get the best from your air conditioner, follow these recommendations:

- close the windows and doors in the room to be air conditioned (fig. 28). When installing the air conditioner semi-permanently, you should leave a door slightly open (as little as 1 cm) to guarantee correct ventilation.
- Protect the room from direct exposure to the sun by partially closing curtains and/or blinds to make the appliance much more economical to run (fig. 29);
- never rest objects of any kind on the air conditioner;
- do not obstruct the air intake and outlet (fig. 30). Leave the grilles free;
- In air conditioning mode, make sure there are no heat sources in the room.
- never use the appliance in very damp rooms (laundries for example).
- never use the appliance outdoors.
- make sure the air conditioner is standing on a level surface. if necessary, place the castor locks under the front wheels.

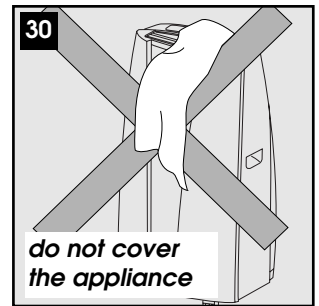
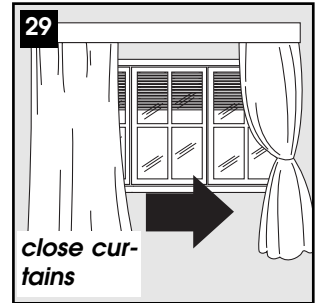
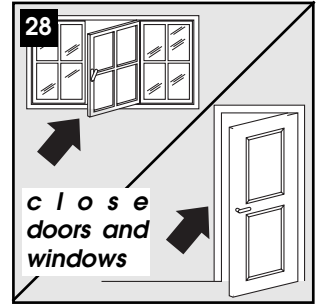

AIR PURIFYING FILTERS

The T130ARC model is fitted with a dust filter which retains impurities in the air drawn in from the room and a 3M® electrostatic filter (fig. 31)

SILVER ION FILTER

The silver ion filter not just retains dust particles, but also has an efficient antibacterial action. It also greatly reduces concentrations of irritants such as pollen and spores.

The filter is treated with small particles of silver (on the scale of millionths of a millimetre) which are able to block the multiplication of and destroy any bacteria or spores they come into contact with.

3M® ELECTROSTATIC FILTER

The 3M® electrostatic filter retains the finest dust particles, thus enhancing the filtering capacity of the appliance.

To use the 3M® electrostatic filter:

- A) Remove the intake grille
- B) Remove the filter from the packaging
- C) Use the two plastic edges of the 3M filter to hook it to the special attachments on the dust filter already inside the intake grille.
- D) Replace the grille on the appliance.

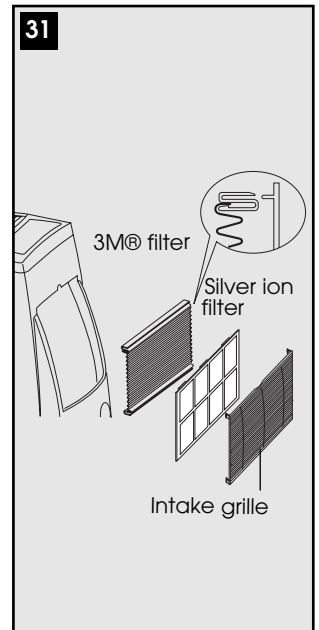

CLEANING

Before cleaning or maintenance, turn the appliance off by pressing the  button on the control panel or remote control, wait for a few seconds then unplug from the mains socket.

CLEANING THE CABINET

You should clean the appliance with a slightly damp cloth then dry with a dry cloth.

- ✓ Never wash the air conditioner with water. It could be dangerous.
- ✓ Never use petrol, alcohol or solvents to clean the appliance.
Never spray insecticide liquids or similar.

CLEANING THE AIR FILTERS

To keep your air conditioner working efficiently, you should:

1. Clean the dust/silver ion filter every week of operation
2. Replace the 3M air purifying filter at the end of each season or when exhausted (see the instructions near the filter housing on the appliance). The filters are housed in the intake grille

To clean the filters, proceed as follows

1. Remove the intake grille by rotating outwards (fig. 32).
 2. Remove the 3M air purifying filter (white) (if present).
 3. Remove the dust/silver ion filter by detaching it from the grille.
- Use a vacuum cleaner to remove dust accumulations from the dust/silver ion filter. If it is very dirty, immerse in warm water and rinse a number of times.
The water should never be hotter than 40°C.
 - After washing, leave the filter to dry.
 - To replace, put the filters back in the intake grille then attach the intake grille to the appliance.

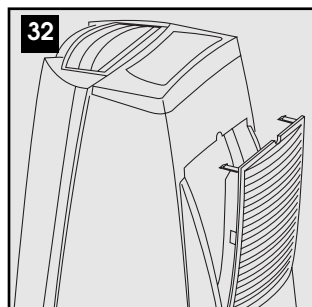

- ✓ **Never try and wash or clean the 3M filter as this could reduce its filtering capacity. When the filter is exhausted, replace it.**

START OF SEASON CHECKS

Make sure the power cable and plug are undamaged and the earth system is efficient. Follow the installation instructions precisely.

END OF SEASON OPERATIONS

Place the appliance in STAND-BY.

To empty the internal circuit completely of water, press the **MODE** and **FAN** buttons simultaneously for a number of seconds without removing the tank. The water in the internal circuit will drain into the tank or through the continuous drain hose if connected. Make sure the other end of the hose is near a suitable drain. When completely drained, disconnect the continuous drain hose. Clean and/or wash the filters and dry thoroughly before putting them back.

TROUBLESHOOTING

PROBLEM	CAUSE	SOLUTION
The air conditioner does not come on	<ul style="list-style-type: none"> • there is no current • it is not plugged into the mains • the internal safety device has tripped 	<ul style="list-style-type: none"> • wait • plug into the mains • call the Service Centre
The air conditioner works for a short time only	<ul style="list-style-type: none"> • there are bends or kinks in the air exhaust hose • something is preventing the air from being discharged 	<ul style="list-style-type: none"> • position the air exhaust hose correctly, keeping it as short and free of curves as possible to avoid bottlenecks. ando qualunque strozzatura • check and remove any obstacles obstructing air discharge
The air conditioner works, but does not cool the room	<ul style="list-style-type: none"> • windows, doors and/or curtains open • there are heat sources in the room (oven, hairdryer, etc) • the air exhaust hose is detached from the appliance • dust or silver ion and 3M® filter clogged • the technical specification of the appliance is not adequate for the room in which it is located. 	<ul style="list-style-type: none"> • close doors, windows and curtains, bearing in mind the "tips for correct use" given above • eliminate the heat sources • fit the air exhaust hose in the housing at the back of the appliance (fig. 1). • clean the filters as described above.
During operation, there is an unpleasant smell in the room	<ul style="list-style-type: none"> • dust or silver ion and 3M® filter clogged. 	<ul style="list-style-type: none"> • clean the filters as described above
The air conditioner does not operate for about three minutes after restarting it	<ul style="list-style-type: none"> • the internal compressor safety device prevents the appliance from being restarted until three minutes have elapsed since it was last turned off. 	<ul style="list-style-type: none"> • wait. This delay is part of normal operation.
The following message appears on the display: LT / PF / FT / FI	<ul style="list-style-type: none"> • The appliance has a self diagnosis system to identify a number of malfunctions. 	<ul style="list-style-type: none"> • See the SELF-DIAGNOSIS chapter.

TECHNICAL SPECIFICATIONS

Mains voltage	see rating plate
Maximum absorbed power in air conditioning	"
Maximum absorbed power in heating	"
Refrigerant	"
Cooling capacity	"
Heating power	"

LIMIT CONDITIONS

Temperature of room in air conditioning	21±35°C
Temperature of room in heating	10±27°C

SIZE OF APPLIANCE

- width 495 mm
- height 950 mm
- depth 410 mm
- weight 34 kg

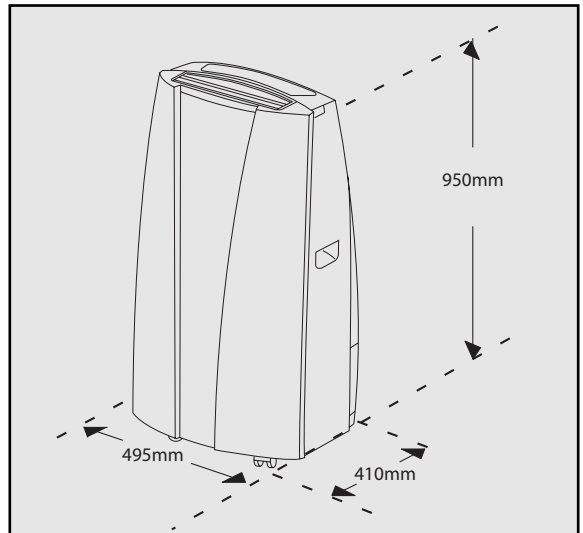

GUARANTEE

The terms of the guarantee and technical assistance are given in the documentation accompanying your appliance.