

G Series DVD Player Installation Guide

Important safety instructions

- Read the instructions.
- Keep these instructions.
- Follow all instructions.
- Do not use this apparatus near water.
- Clean only with a dry cloth.
- Install only in accordance with the manufacturer's instructions.
- Refer all servicing to approved service personnel.

WARNING: TO REDUCE THE RISK OF FIRE OR ELECTRIC SHOCK,
DO NOT EXPOSE THIS APPARATUS TO RAIN OR MOISTURE

Safety warnings

- Do not expose the product to dripping or splashing.
- Do not place any object filled with liquid, such as a vase, on the product.
- Do not place naked flame sources, such as lighted candles, on the product.

To avoid overheating

Do not position the product:

- In direct sunlight.
- Near heat sources, such as a radiator.
- Directly on top of heat producing equipment, such as a power amplifier.

The product normally runs warm to the touch.

To avoid interference

Do not position the product:

- Near strong magnetic radiation, such as near a power amplifier.
- Near to a television, or where connecting cables may be subject to or cause interference.

Radio interference

FCC Warning: This equipment generates and can radiate radio frequency energy and if not installed and used correctly in accordance with our instructions may cause interference to radio communications or radio and television reception. It has been type-tested and complies with the limits set out in Subpart J, Part 15 of FCC rules for a Class B computing device. These limits are intended to provide reasonable protection against such interference in home installations.

EEC: This product has been designed and type-tested to comply with the limits set out in EN55013 and EN55020.



Contents

Introduction	1	Configuring playback options	45
Provides information about the DVD player models, a description of each product, and technical specifications.		Explains how to use the options on the Setup menu to configure the playback options of the DVD player.	
DVD player models	1	Setting playback options	45
Specifications	6	Region codes	49
		Video controls	50
Installing the DVD player	7	Troubleshooting	51
Describes how to install the DVD player and connect it to the other equipment in the system.		Provides suggested solutions to problems while installing, configuring, or operating the product.	
Unpacking	7	Maintenance	54
Audio connections	8	Service and guarantee	55
Video connections	17	Index	57
Tuner (G91 only) and communications connections	22		
Resetting the DVD player	25		
Explains how to reset the DVD player using the front-panel controls.			
Resetting the product	25		
Configuring the DVD player	27		
Explains how to configure the DVD player using the on-screen setup menus.			
Configuration	27		
Configuring the video	29		
Configuring the audio	34		
Configuring the sources	41		
Configuring settings	43		

Copyright and acknowledgements

Sales and service in the UK

Meridian Audio Ltd
Stonehill
Stukeley Meadows
Cambridgeshire
PE29 6EX
England

Tel +44 (0)1480 445678
Fax +44 (0)1480 445686

<http://www.meridian-audio.com/>

Copyright © 2003 Meridian Audio Ltd

Designed and manufactured in the UK by Meridian Audio Ltd. Meridian Audio reserves the right to make changes and improvements to any of the products described in this document without prior notice.

Dolby, Dolby Digital, Pro Logic, AC-3, PLII, and the double-D symbol are trademarks of Dolby Laboratories Licensing Corporation. DTS is a registered trademark of Digital Theatre Systems Inc. MPEG is a registered trademark of the MPEG organisation. Trifield is a trademark of Trifield Productions Ltd. HDMI, the HDMI logo, and High-Definition Multimedia Interface are trademarks or registered trademarks of HDMI Licensing LLC.

Boothroyd|Stuart Meridian, Meridian, and Meridian Digital Theatre are registered trademarks of Meridian Audio Ltd.

Part no: GDVD/1

Sales and service in the USA

Meridian America Inc
3800 Camp Creek Parkway
Building 2400
Suite 122
Atlanta GA 30331
USA

Tel +1 (404) 344 7111
Fax +1 (404) 346 7111

This guide was produced by Human-Computer Interface Ltd,
<http://www.interface.co.uk/>

Manufactured under license from Dolby Laboratories Licensing Corporation (Canadian patent 1,037,877), Lucasfilm Ltd. (US patents 5,043,970; 5,189,703; 5,222,059. European patent 0323830), Trifield Productions Ltd, and Nimbus Records Ltd.

Macrovision: This product incorporates copyright protection technology that is protected by US patents and other intellectual property rights. Use of this copyright protection technology must be authorized by Macrovision, and is intended for home and other limited viewing uses only unless otherwise authorized by Macrovision. Reverse engineering or disassembly is prohibited.

MHR: This product incorporates copyright protection technology covered by certain patent applications and intellectual property of Meridian Audio Ltd. This technology is provided for the express purpose of securely containing copyright audio within the Meridian System only. Reverse engineering or circumvention of this protection is strictly prohibited.

Introduction

This guide provides full information about unpacking the DVD player, connecting it to the other equipment in the system, and configuring it using the front panel. Once you have connected and configured the DVD player, refer to the *G Series System Guide* for information about operating it.

DVD player models

The G Series includes three models of DVD player. All three play audio-CDs, MP3 CDs, Video CDs, DVD-Video, and DVD-Audio discs. They can all decode Dolby Digital, DTS, MPEG, MP3, and MLP data streams to PCM for stereo, and in some cases multichannel, playback. They can all optionally output Dolby Digital, DTS, and MPEG bitstreams for connection to a surround controller (Type 2, see page 14).

G98AH and G98DH

Audio

The G98 is the ideal partner for the G68 Digital Surround Controller. The G98AH and G98DH are DVD-Audio transports that provide fixed-level multichannel or two-channel audio outputs. They are designed for use with a surround controller with multichannel analogue (G98AH) or digital (G98DH) inputs (Types 3/4/5, see page 13). Alternatively, either model can be connected to a pair of DSP

loudspeakers to create a complete high-quality two-channel DVD system (Type 1, see page 11).

Video

The G98AH and G98DH include a powerful video processor and scaler which can simultaneously provide composite and S-video outputs, plus progressive component video and up to 1080i on an HDMI output. They provide two composite, three S-video, and one interlaced component video input, all of which can be routed to any of the video outputs with appropriate scaling.

G91

Audio

The G91 incorporates a two-channel preamplifier with two coax digital inputs, two optical inputs, and three analogue inputs. It provides analogue and fixed digital stereo outputs. The G91 includes digital signal processing to upsample decoded streams, or decode bitstreams from external sources. It also includes a high-quality FM/AM tuner with RDS.

It is designed to connect directly to a pair of analogue active speakers, or power amplifiers and passive speakers (Type 0, see page 12), or a pair of DSP speakers (Type 1, see page 11), to create a complete two-channel AV system.

In addition the G91 provides a multichannel digital output to allow connection to a surround controller with multichannel digital inputs (Type 3/4/5, see page 13). Alternatively the multichannel digital output and stereo analogue output can be used to directly drive

a basic 5.1 surround system based on Meridian DSP loudspeakers and up to two analogue speakers (left and right, centre, subwoofer, centre and subwoofer, or rear left and right) (Type 6, see page 15).

Video

The G91 provides the same video routing and scaling as the G98.

The main differences between the three models are explained in the following table:

Product	Audio inputs	Audio outputs	Video inputs	Video outputs	Radio tuner
G91	3 analogue, 2 optical, 2 digital	Analogue and digital 2 channel, digital 6 channel	2 composite, 3 S-video, 1 interlaced component	Progressive component and scaled HDMI	Yes
G98DH	None	Digital 2 channel and 6 channel	2 composite, 3 S-video, 1 interlaced component	Progressive component and scaled HDMI	No
G98AH	None	Analogue 6 channel or 2 channel, and digital 2 channel	2 composite, 3 S-video, 1 interlaced component	Progressive component and scaled HDMI	No

All models provide an S-video and composite video outputs.

Description of features

DVD-ROM drive

At the heart of the G Series DVD players is a high-speed computer-style DVD-ROM drive – the best type of drive to use to ensure accurate data recovery from all types of disc, while providing a stable platform that can be changed in the future, if necessary, to keep pace with new requirements.

In addition to regular CDs (including MP3 CD-ROMS) and DVDs, the players can also play most hybrid varieties. The players can handle both DVD-Video and DVD-Audio discs, decoding Dolby Digital, DTS or MLP data streams and extracting or downmixing them to stereo if required.

The drive normally operates at standard speed; however it is capable of recovering data a great deal faster when required, enabling it to make more attempts to recover accurate data from

a problem disc. Because of this, the drive can perfectly recover the data from nearly all discs.

Unlike other players that use a mechanical approach to try to lower jitter by minimising drive vibration, the G Series DVD players employ a triple buffering system to minimise jitter, maximizing HF transparency and sound stage precision and stability. The result of this sophisticated effort is that the players deliver ultra-low jitter, with sound and picture quality second only to Meridian's 800 Reference DVD/CD Player.

The digital electronics as a whole are driven by a new design of high-stability clocking system which further reduces jitter and ensures that the highest level of detail is recovered from a disc. All digital data is accurately re-clocked. Multiple power supplies ensure that digital and analogue circuitry are kept separate.

User interface

The G Series DVD players include a comprehensive front-panel user interface which allows access to all the features of the unit. The players can be reset to a standard Type which configures all the required settings as appropriate for a particular application. In addition, an on-screen display (OSD) allows you to configure specific settings individually.

The players employ Flash ROM memory for the operating system, so software updates can be downloaded from the Internet and installed via a PC connected to the serial port on the back panel. The serial port also allows full remote control and configuration of the unit.

Audio

The G98DH and G91 provide three principal S/PDIF coax outputs designated L/R, L/R Surround, and C/LFE. These typically connect to Meridian processors, or feed a stereo signal to a pair of DSP loudspeakers. If configured for MHR SmartLink they, or the adjacent combined 15-way D-type connector, carry high-sample rate encrypted data from DVD discs for the highest fidelity of decoding and reproduction. The SmartLink also informs a downstream Meridian processor of the signal source, so that it can switch processing modes automatically.

The G98AH provides six channels of analogue output. These feature true 24-bit DACs that operate at sample rates up to 192kHz for the maximum possible audio quality. The audio connectors have gold-plated contacts.

All models provide an additional S/PDIF digital output which delivers a stereo downmix or bitstream signal.

Preamplifier and tuner

The G91 includes a preamplifier and integral radio tuner. The main stereo analogue preamp output is either fixed, or variable via the front-panel knob which controls the Meridian proprietary digital/analogue volume control as used in the 800 Series and DSP 8000.

The tuner provides AM (LW/MW) and FM (VHF stereo Band II) reception with RDS and is fitted with its own 96kHz, 24-bit A/D stage. Digital signal processing provides a sophisticated FM stereo blend/width control which allows the user to minimise noise on

a received signal. There is also a DSP-based low-pass filter and a whistle filter for improved AM reception.

Upsampling

The G91 provides upsampling, which allows filtering to take place far beyond the range of human hearing, as well as offering other audible benefits right across the audio band, including improved transient response. All processing is 48-bit precision. This results in a more open, transparent sound, tighter bass, and a generally more 'musical' sound overall.

To drive the analogue outputs, signals are upsampled to 176.4/192kHz for digital to analogue conversion – DACs can offer better performance at higher sampling rates – and 88.2/96kHz is used for the digital outputs, all at 24-bit word lengths.

Here again, sending 24 bits at high sample rates via an S/PDIF link reduces jitter as compared with the original 44.1kHz, 16-bit signal from a CD, for example. In addition, digital outputs derived from high resolution sources are encrypted, removing cyclic components from the data stream and again reducing jitter.

All these advanced digital processing features are handled by a powerful DSP engine delivering an impressive 150MIPS (million instructions per second).

Digital surround processing

In addition, the G91 incorporates digital signal processing to allow the multichannel digital output and stereo analogue output to be used to directly drive a basic 5.1 surround system based on

Meridian DSP loudspeakers and up to two analogue speakers (left and right, centre, subwoofer, centre and subwoofer, or rear left and right).

A setup option allows you to define the configuration of loudspeakers in the layout, and specify whether the bass is handled by a subwoofer, or the speakers in the layout with good bass handling. A separate **Calibration** page allows you to calibrate the layout by adjusting the gain and distance of each loudspeaker, while listening to test signals. This lets you fine tune the layout for an optimum surround image.

The built-in surround processing decodes 5.1 Dolby Digital or DTS soundtracks from DVD-A or DVD-V discs, or from the external digital inputs. It will also create a full surround image from two-channel soundtracks on audio CDs, DVD-A or DVD-V discs, or from the external two-channel digital or analogue inputs.

Several DSP presets are provided to allow you to choose the type of surround processing. For 5.1 audio formats a Discrete or Cinema DSP preset is selected automatically, depending on whether the source is music or a movie. For two-channel audio formats the DSP preset can usually be switched between Trifield (recommended for music), Stereo (uses just the main left and right speakers and subwoofer), or PLII (recommended for movies), using the DSP key on the front panel or MSR+.

The default preset is Trifield for audio CDs, two-channel DVD-As, the internal tuner, or a two-channel external input, and PLII for two-channel DVD soundtracks or a two-channel Dolby Digital

source on an external digital input. You can change the default DSP preset for a particular source and audio format using the **Assign** key on the front panel.

Note: Trifield is not available for Dolby Digital or DTS two-channel external inputs. Trifield and PLII are not available if the output is downsampling to 48kHz.

Video

On the video side, advanced video circuit designs, matched phase video filters, and a broadcast-quality video encoder are employed to deliver low-noise images of outstanding colour depth and resolution. Separate ultra-low jitter master video and audio oscillators allow picture and sound to be independently optimized, ensuring that the G Series DVD players deliver breathtakingly clear pictures.

Video processor/scaler

All models include a unique high-resolution video processor/scaler. This processor can receive composite, S-video, and interlaced component, and convert between the formats, or to the high-density multimedia interface (HDMI) standard, to provide a single video output for all the video sources in the system. A bypass function allows progressive or high definition component video to be routed directly to the component output only.

The HDMI port also carries high-resolution digital audio, either two channels of PCM at up to 96kHz or a 5.1 channel bitstream. Built-in broadcast-quality circuits and both Meridian and Faroudja video

processing deliver the most advanced, high-quality video available today. The HDMI port supports a wide range of high quality digital video options including 480p, 576p, 720p, and 1080i. A unique feature of HDMI is that it is able to 'handshake' between the source and the display to find the highest quality format. Analogue component out is available at 480p and 576p.

The video processor includes picture controls, available via the MSR+ and front-panel display. For the internal DVD and external video inputs you can adjust the output aspect ratio, horizontal picture position, and vertical picture position. In addition for the video inputs you can adjust the brightness, contrast, colour, and hue (NTSC inputs only).

The HDMI output can be connected to a DVI input if the device supports HDCP copy protection, using a suitable adaptor cable.

Specifications

	G91	G98DH	G98AH
Audio inputs	Analogue: 3 stereo inputs, unbalanced 0.5-2.5V on phono. Digital S/PDIF: 2 stereo coax inputs and 2 stereo Toslink optical inputs.	None.	None.
Digital outputs	MHR SmartLink digital output on 3 digital coax outputs or 15-pin D-type connector. Aux digital coax output.		1 aux digital coax, 1 aux optical.
Analogue outputs	Stereo preamp output, fixed or variable 1-99 in 1dB steps, 3V RMS, 47Ω.	None.	6-channel analogue output on phonos, 2V RMS, 47Ω.
Upsampling	On preamplifier output to 176.4/192kHz. On digital output to 88.2/96kHz.	No.	No.
DSP modes	PLII, Trifield, Stereo, Discrete, Cinema.	None.	None.
Video outputs	Composite, S-video, component (75Ω), and HDMI outputs (HDMI also carries audio and is DVI-HDCP compatible via an adaptor cable), all simultaneously active. Selected video input is converted to all formats at valid resolutions. HDMI port supports 480p, 576p, 720p, and 1080i. Analogue component out is available at 480p and 576p.		
Video inputs	1 component interlaced, 2 composite, and 3 S-video. Progressive/high definition component in will be switched to component out but is not scaled or converted to S-video, composite, or HDMI.		
Video features	Automatic PAL or NTSC encoding on composite and S-video. NTSC black-level setup adjustable as 0 or 7.5IRE. 16:9 and 4:3 displays supported. Video controls: picture position, black level, contrast, colour, and hue.		
Tuner	24/96 A/D converter. AM (Long/Medium Wave, 150-285/525-1605kHz); FM (VHF Band II, 87.5-108MHz), sensitivity 1.5μV. DSP processing for FM stereo/mono blend and width; AM low-pass and whistle filters.	None.	None.
Trigger output	12V, 100mA, configurable by source.		
Comms	Two 5-pin 240° DIN sockets, BNC socket, RS232 interface.		
Formats	DVD-Audio, DVD-Video, DVD-R; Video CD (VCD), CVCD, MP3; CD Audio (CD-DA), including CD-R and CD-RW.		
Power	Universal supply, 100-240VAC, 50/60Hz, 25VA.		
Dimensions	440mm x 90mm x 350mm (17.32" x 3.54" x 13.78") WHD.		
Weight	9kg (20lb) approx.	9kg (20lb) approx.	9kg (20lb) approx.
Controls	Front-panel soft keys include control of Play, Stop, Pause, Previous, Next, etc. Power button, Open/Close tray button, volume control. Full remote control of all features via MSR+.		
Display	Multi-character dot-matrix Vacuum Fluorescent Display (VFD). Switchable custom OSD allows instant review of disc status. Screen saver with user timeout options. Logo screen with pluge bars enables brightness setting of display device.		

Installing the DVD player

This chapter explains how to install the DVD player. It describes what you should find when you unpack the product, and how you should connect it to the other equipment in the system. You should not make any connections to the product or to any other component in the system while the AC power supply is connected and switched on.

Unpacking

The G91 DVD Audio Player Controller Tuner and G98 DVD Audio Transport are supplied with the following accessories:

- MSR+ remote control with batteries, manual, and spare key caps.
- Meridian Comms lead.
- AM antenna (G91 only).
- FM antenna (G91 only).
- 2 FM antenna adaptors (G91 only).
- Ferrite bead*.
- Power cord.
- This manual.
- *Meridian G Series System Guide*.

*If a trigger cable is used this should be clamped around the cable near the DVD player.

If any of these items are missing please contact your dealer.

Note: You should retain the packaging in case you need to transport the unit.

Audio connections

All the G Series DVD players provide a digital output, suitable for connecting to a pair of Meridian DSP loudspeakers or a surround controller.

The G98 is available with either a multichannel analogue output or a multichannel digital output for connection to a surround controller with multichannel inputs such as a G68.

The G91 is fitted with a multichannel digital output card.

Multichannel digital output (G91, G98DH)

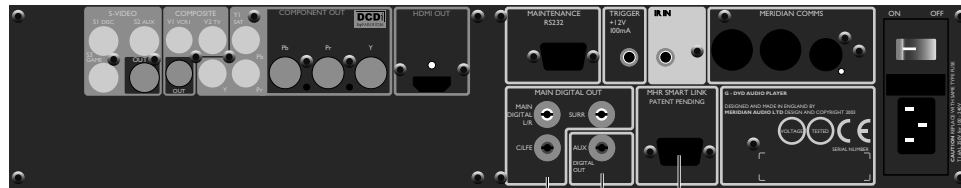

Multichannel digital outputs

MHR SmartLink output

Digital output

Use this output

MAIN DIGITAL OUT (L/R)

MAIN DIGITAL OUT, C/LFE,
SURROUND

AUX DIGITAL OUT

SMARTLINK*

To connect to this

The digital input of a surround processor without multichannel digital inputs, or a pair of DSP loudspeakers.

The multichannel digital input of a digital surround processor such as a G68 or 861.

The digital input of an additional surround processor or a pair of DSP loudspeakers, when the main output is being used for multichannel audio.

A Meridian surround processor with an MHR SMART LINK input, such as the 568 Digital Surround Processor, using the SmartLink cable supplied with the 568 or an SVGA computer monitor lead.

*MHR SmartLink is available from either the MHR SMART LINK output or the MAIN DIGITAL OUT L/R, C/LFE, and SURR outputs; they are equivalent.

Multichannel analogue output (G98AH)

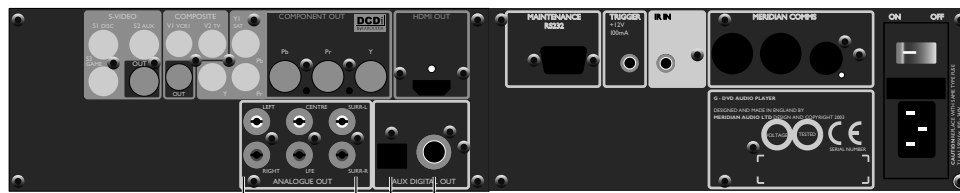

Multichannel analogue outputs

Digital output

Optical output

Use this output

ANALOGUE OUT LEFT, RIGHT,
CENTRE, LFE, SURR-L, SURR-R
AUX DIGITAL OUT
AUX OPTICAL OUT

To connect to this

The multichannel analogue inputs of a surround controller such as the G68 Digital Surround Controller.
The digital input of a surround controller, or a pair of DSP loudspeakers.
The optical input of a surround controller.

Preamplifier and tuner connections (G91)

The G91 includes an integrated preamplifier, allowing you to connect up to seven external sources in addition to the DVD player and internal tuner. These versions of the DVD player provide the option of a decoded two-channel analogue or digital output, for connection to an external amplifier, analogue active speakers,

or digital active speakers. Alternatively they can be configured to provide a bitstream digital output, suitable for connection to an external digital surround processor such as the G68 Digital Surround Controller.

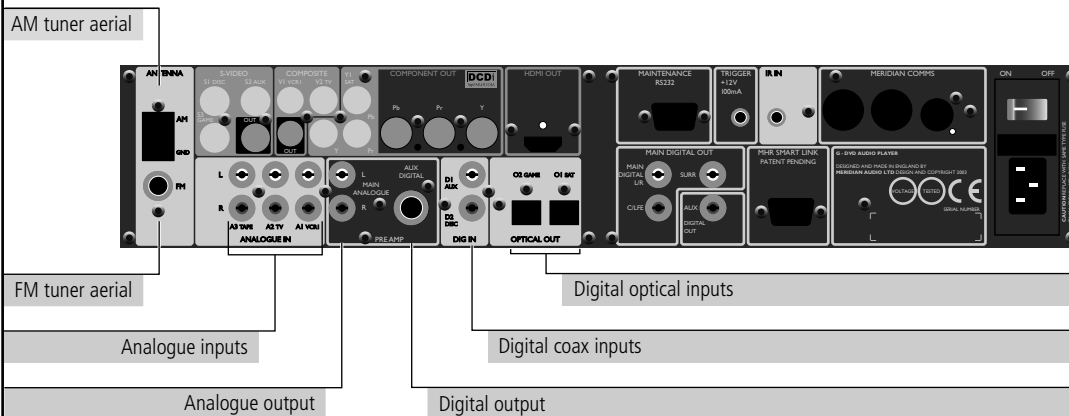

Use this connector

ANALOGUE IN A1 (VCR1), A2 (TV), A3 (TAPE)

DIG IN D1 (AUX), D2 (DISC)

OPTICAL INPUT O1 (SAT), O2, (GAME)

PRE OUT AN

AUX OUT DIGITAL

TUNER AM, FM

To connect to this

The analogue outputs of a source, such as a TV or tape deck.

The digital output of a source such as a LaserDisc player.

The optical output of a source such as a satellite receiver.

The analogue inputs of a power amplifier, or active analogue loudspeakers.

The digital input of an additional surround processor or a pair of DSP loudspeakers, when the main output is being used for multichannel audio.

AM and FM antennae for the tuner.

The default assignment of the sources to each input are shown in brackets after the input name in the above table. DVD and RADIO correspond to the internal DVD player and tuner.

Applications

To connect to two-channel DSP loudspeakers (Type 1)

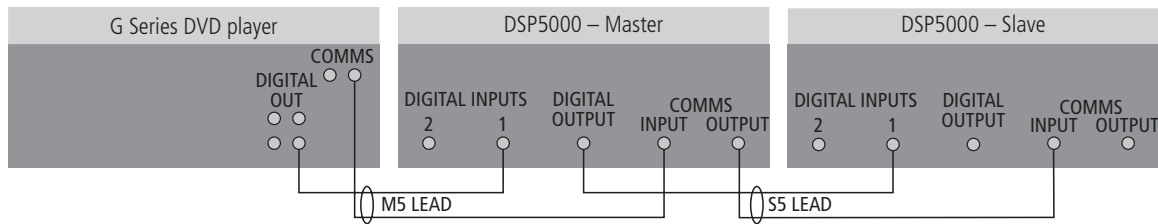

G Series DVD players can be connected directly to Meridian DSP loudspeakers to create a complete compact stereo system, with volume and other preamplifier controls provided by the loudspeakers via the MSR+ or the front panel. The G91 provides additional analogue and digital inputs allowing you to use it to control the other sources in your system.

- Connect the MAIN DIGITAL OUT L/R (G91 or G98DH), or AUX DIGITAL OUT (G98AH) and a COMMS socket from the DVD player to DIGITAL INPUT 1 and the COMMS input on the DSP loudspeaker chosen as the master, using an M5 lead.
- Connect the DIGITAL and COMMS outputs from the master DSP loudspeaker to DIGITAL INPUT 1 and the COMMS input on the other (slave) DSP loudspeaker, using an S5 lead.
- Configure the loudspeakers as described in the *Meridian DSP Loudspeaker User Guide*.
- Configure the DVD player to Type 1; see *Resetting the DVD player*, page 25.

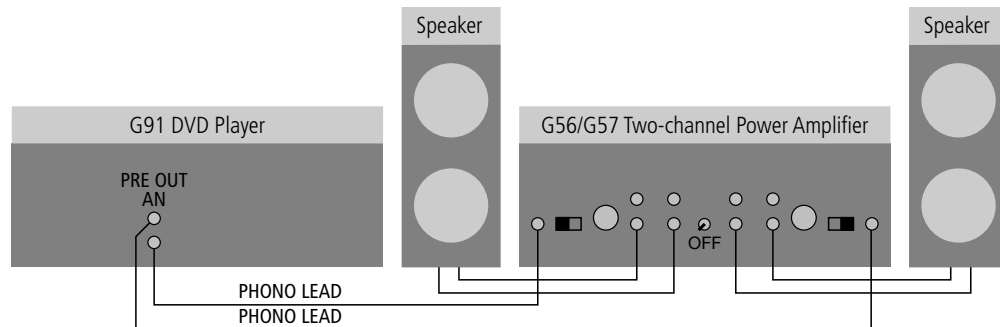
To connect the G91 to two-channel analogue variable (Type 0)

The G91 includes an integrated preamplifier, allowing you to connect it directly to a pair of analogue active loudspeakers, or to analogue passive loudspeakers via a power amplifier such as the G56 or G57.

- Connect the PRE OUT AN outputs from the DVD player to the inputs of the analogue active loudspeakers or power amplifier, using phono leads.
- Configure the DVD player to Type 0; see *Resetting the DVD player*, page 25.

To connect to a surround processor with multichannel digital inputs eg G68 (Type 3/4/5)

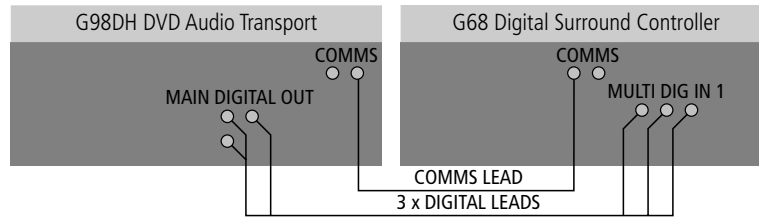

The multichannel digital output is the preferred way of connecting to a 96kHz and MHR capable Meridian digital surround processor, such as a 568.2, G68, or 861, as it provides additional MHR SMART LINK information about the source format.

- Connect the MAIN DIGITAL OUT L/R, C/LFE, and SURROUND outputs from the G Series DVD player to the digital multichannel inputs on the G68D, using three phono leads.

Alternatively, if the digital surround controller is a Meridian 568 connect the MHR SMART LINK connectors using an SVGA cable.

If the surround processor is a Meridian product connect together the COMMS socket using the Comms lead provided.

- Configure the DVD player to Type 3, 4 or 5, depending on the video configuration; see *Resetting the DVD player*, page 25.

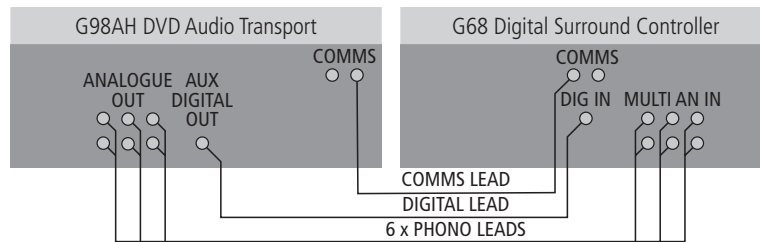
To connect to a surround processor with multichannel analogue inputs eg G68 (Type 3/4/5)

- Connect the ANALOGUE OUT sockets from the G98AH to the analogue multichannel inputs on the surround processor.
- Optionally connect the AUX DIGITAL OUT socket to the surround processor's digital input, using a digital phono lead.

If the surround processor is a Meridian product connect together the Comms sockets using the Comms lead provided.

- Configure the DVD player to Type 3, 4 or 5, depending on the video configuration; see *Resetting the DVD player*, page 25.

This gives you the option of decoding Dolby Digital and DTS bitstreams using the surround processor.

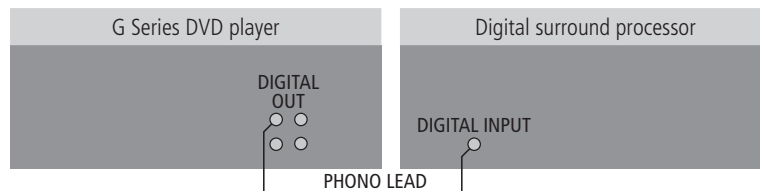
To connect to a surround processor with no multichannel input eg 561 (Type 2)

If your digital surround processor does not provide a multichannel input, and is 48kHz max with no MHR:

If the surround processor is a Meridian product connect together the COMMS sockets using the Comms lead provided.

- Connect the MAIN DIGITAL OUT L/R (G91 or G98DH) or AUX DIGITAL OUT (G98AH) to the DIGITAL IN on the digital sound processor.

- Configure the DVD player to Type 2; see *Resetting the DVD player*, page 25.

To create a surround system with a G91 (Type 6)

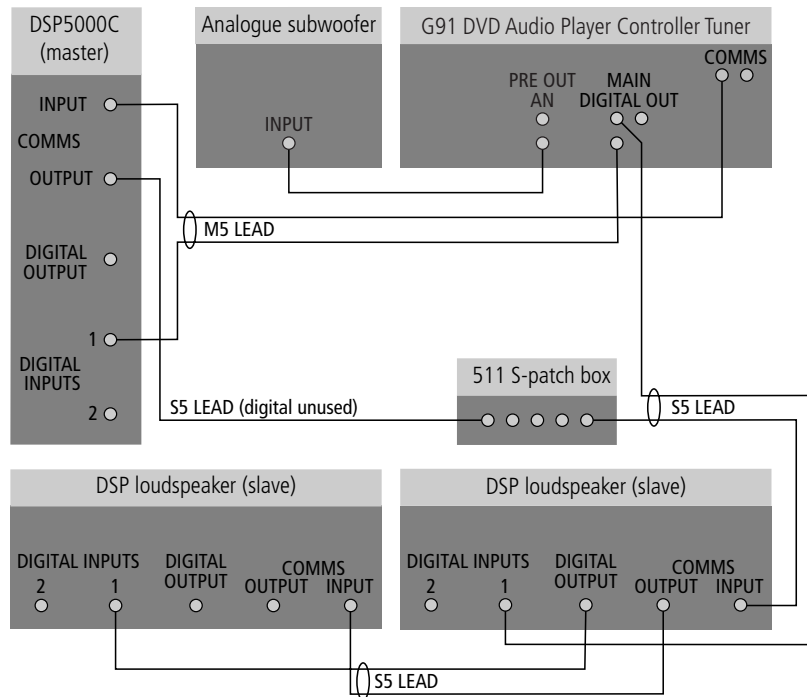

The G91 includes all the digital signal processing needed to create a 5.1 surround system.

- Use the Comms part of an M5 lead to connect one of the COMMS sockets on the G91 to the digital speaker you have chosen as the master (typically the centre speaker).
- Use the audio part of the M5 lead to connect the digital speaker to the appropriate digital output socket.

If the system includes more than two Meridian DSP loudspeakers you will need a 511 S-patch box (available separately) to link together the S5 leads from each speaker.

- Connect the COMMS output from the master digital speaker to one socket on the 511 using an S5 lead.
- Link each pair of speakers together with an S5 lead, out of the first speaker and into the second speaker, as shown in the diagram for the main left and right speakers

- Connect the inputs to the first speaker of each additional pair to the 511 (Comms) and the appropriate output of the G91 (audio), using an S5 lead.
- Connect up to two analogue loudspeakers to the PRE OUT AN outputs. These can be L/R, C, Sub, C/Sub, or Rears.
- Configure the DSP loudspeakers as described in the *Meridian DSP Loudspeaker User Guide*.
- Configure the DVD player to Type 6; see *Resetting the DVD player*, page 25.
- Configure the surround system as described in *To configure speakers (G91 only)*, page 39.

Video connections

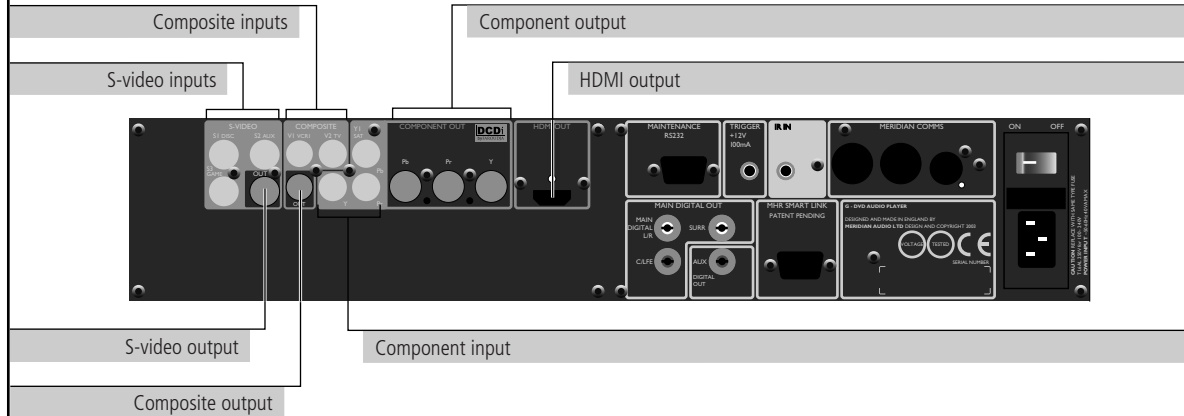
**Video outputs****Use this output**

HDMI OUT
COMPONENT OUT
S-VIDEO OUT
COMPOSITE OUT

To connect to this

The HDMI input on a monitor or high-definition television.
The component or progressive component video inputs on a monitor or projection television.
The S-video input on a monitor or television.
The composite video input on a monitor or television.

Video inputs**Use this input**

S-VIDEO, S1 (DISC), S2 (AUX), S3 (GAME)
COMPOSITE V1 (VCR1), V2 (TV)
COMPONENT Y1 (SAT)

To connect to this

The S-video output of a source such as a LaserDisc player or video game.
The composite output of a source such as a television tuner or VCR.
The component output of a source such as a satellite receiver.

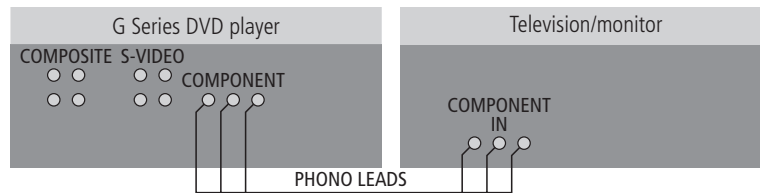
To connect using component video

If your television, monitor, or projection system includes component video inputs, but no HDMI or DVI-HDCP, these will give the highest possible quality from DVD-Videos.

- Connect the appropriate component outputs from the DVD player to the component video inputs, using suitable video cables.

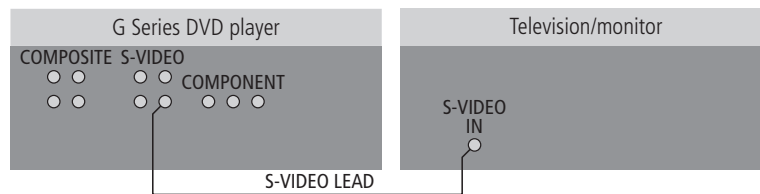
To connect using S-video

- Connect the S-video output to a corresponding input on a television, monitor, or video control unit, using a suitable S-video cable.

The S-video output is recommended if your other equipment provides a choice of both S-video and composite inputs.

The S-video output is always active, irrespective of the **Video output** setting.

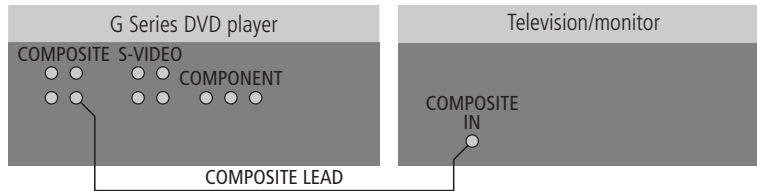
To connect using composite video

- Connect the composite video output to a corresponding input on a television, monitor, or video control unit using a screened 75Ω video cable.

The composite video output is always active, irrespective of the **Video output** setting.

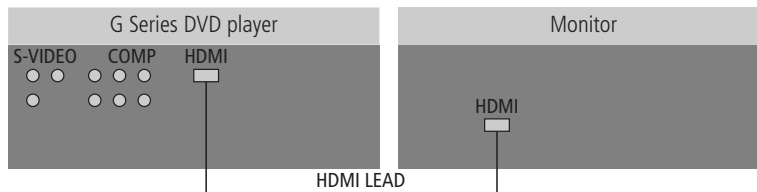
To connect using HDMI

- Connect the HDMI output to the HDMI input on the monitor using an HDMI cable.

HDMI carries the AUX audio output stream, providing either bitstream DD/DTS or two-channel PCM. To do this set the **Application to Aux Out**; see *DVD player application*, page 34. Also, set the **Aux out Max rate to 48kHz**; see *To specify the auxiliary output settings*, page 36.

HDMI can be connected to a DVI input if the monitor supports HDCP copy protection, using a suitable adaptor cable. In this case **DVI mode** should be set to **DVI** in the **HDMI setup** menu; see *To set the HDMI options*, page 33.

Using the G Series DVD player with a G68 Digital Surround Controller

To connect to a G68D with video switching in the DVD player (Type 3)

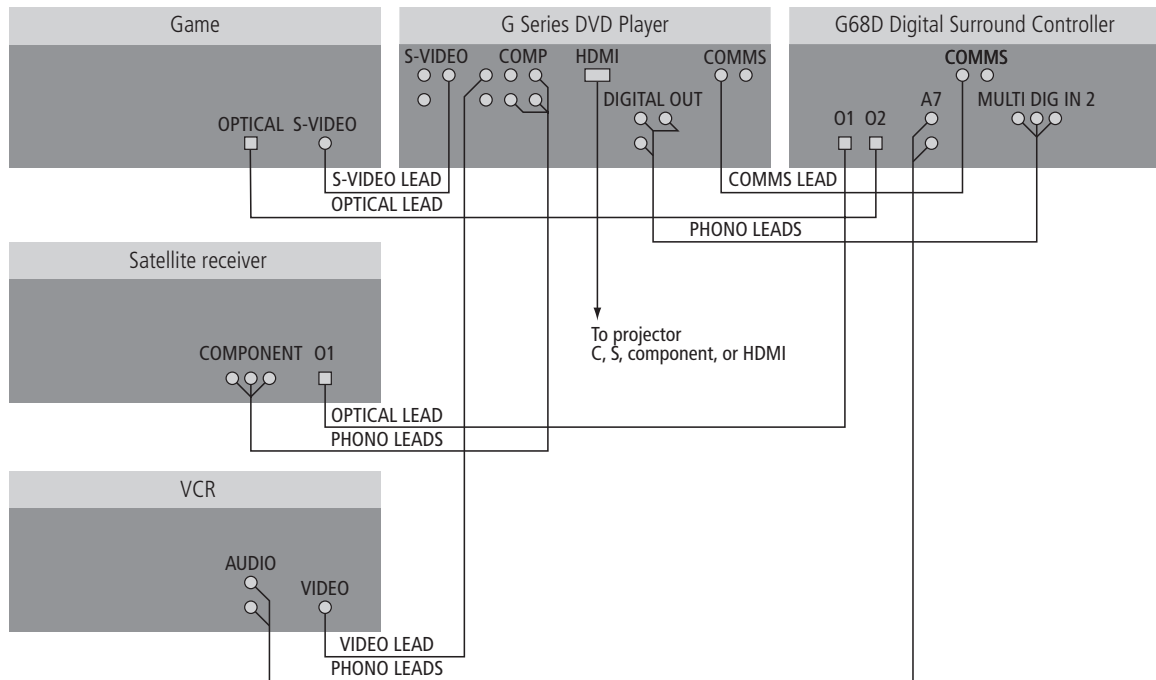

The G Series DVD player can be used in combination with a G68 Digital Surround Controller to create a superb audio/video system, using the video switching and format conversion provided by the DVD player to handle the video, and the audio switching provided by the G68 to handle the analogue and digital audio.

- Connect the video sources to the COMPOSITE IN, S-VIDEO IN, and COMPONENT IN sockets on the DVD player.
- Connect the audio sources to the DIGITAL IN and ANALOGUE IN sockets on the G68.
- Connect the appropriate output from the DVD player to your display device.
- Connect together the COMMS sockets of the DVD player and G68 using the Comms lead provided.
- Configure the DVD player to Type 3; see *Resetting the DVD player*, page 25.

To connect to a G68ADV/AXV/XXV with video switching in the G68 and scaling in the G98 (Type 4)

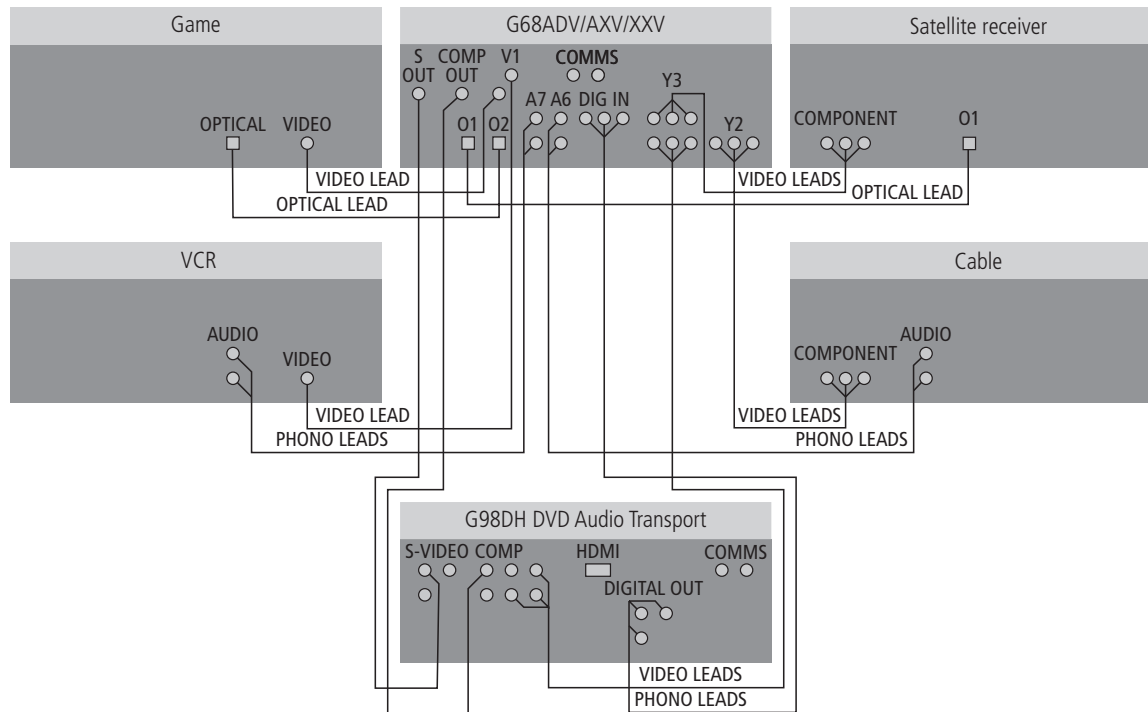

If you are using the G98DH in conjunction with a G68ADV, AXV, or XXV Digital Surround Controller, you can perform video switching in the G68 but take advantage of the video format conversion and scaling in the G98 to drive the display device.

- Connect the composite, S-video, and component outputs from the G68 to the corresponding inputs on the G98.
- Connect the video sources to the COMPOSITE IN, S-VIDEO IN, and COMPONENT IN sockets on the G68.
- Connect the appropriate output from the G98 to your display device.
- Connect together the COMMS sockets of the G98 and G68 using the Comms lead provided.
- Configure the G98 to Type 4; see *Resetting the DVD player*, page 25.

Tuner (G91 only) and communications connections

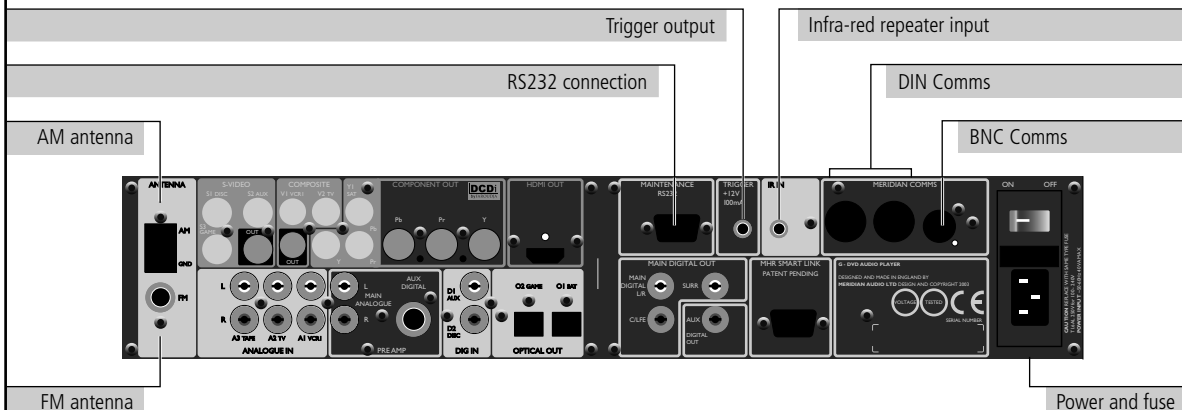
**Use this connection**

DIN COMMS

BNC COMMS

RS232 connection

IR IN

TUNER AM, FM

TRIGGER OUTPUT

To connect to this

Other Meridian G Series, 500 Series, or 800 Series equipment, or Meridian DSP loudspeakers.

Future Meridian components.

A computer, for configuring the DVD player.

A G12 IR Receiver, or approved alternative infra-red repeater. Contact your dealer for details.

AM and FM antennae.

Other equipment, via a mono 3.5mm jack output (centre pin hot) that provides 12VDC (8VDC on G02). It is always low in standby. By default it is high for all sources, so can be used to bring a G56 or G57 Two-channel Power Amplifier out of standby. Alternatively you can program it to be high for specific sources; eg to control a projection screen.

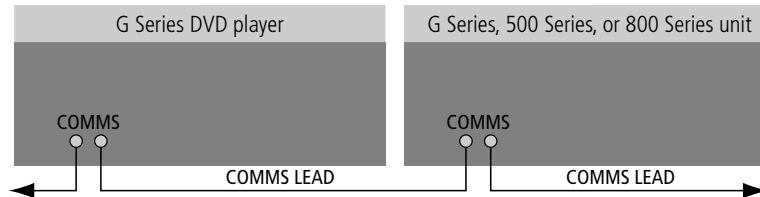
To connect to other Meridian G Series, 500 Series, or 800 Series equipment

In a system of Meridian products, one of the products acts as the controller for the system, receiving infra-red commands from the MSR+, and then, if appropriate, relaying them to the other products via the Comms link.

The following procedure should be used to set up the Comms correctly between several products:

- Connect one of the DIN COMMS sockets on the back panel of the DVD player to one of the COMMS sockets on another G Series, 500 Series, or 800 Series unit, using the Comms leads provided with the products.

The sequence in which you connect the units is not important.

- Switch all the units to standby.
- Press **Clear** (MSR+).

Each unit will display:

Auto

One unit will then be designated as the controller, and display:

Con.

All the other units will be configured as non-controllers, and display:

Not Con.

The system is now ready for use.

If the automatic setup does not work, first make sure you are operating the MSR+ from a position where all the units can receive the infra-red, and try again. Then:

- Check that none of the units have been configured to be IR Controller; see *Configuring settings*, page 43. Either all products should be set to Auto, or one should be configured as Controller and the others as Not Controller.

Note: Do not, under any circumstances, connect any equipment other than Meridian G Series, 500 Series, or 800 Series to the socket marked COMMS on the back of the product.

To connect FM and AM antennae (G91 only)

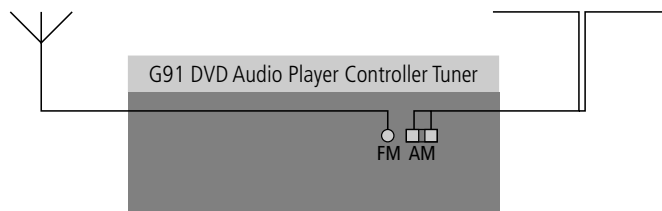

- Connect an FM antenna or split-flex dipole to the FM Coax connector, if necessary using the adaptor provided.

In the UK use a female Belling-Lee (VCR) connector.

Although the FM tuner is very sensitive, for best performance and lowest noise use a good antenna placed as high as possible and oriented towards the transmitter.

Note: For all outdoor antennae we strongly recommend you use a qualified installer who will comply with local safety regulations.

- Connect an AM antenna to the AM connector by pressing the tabs and inserting a bare wire into each hole. The ground connection should be connected to the socket marked GND.

The product is supplied with an indoor loop antenna. This is directional, and for best results you will need to orient it, and this may be station dependent.

- Place the antenna as far away from other electrical equipment and as high as possible.

For best AM results use an external AM antenna.

Note: For AM you must fit a good ground as well as an antenna.

The Tuner can be used with most proprietary indoor AM, FM, or combi (AM/FM) antennae. It is possible in some cases to use a trigger output (+12V) from the G91 to power such devices. For more details, see the **Library: Application Notes** section of the Meridian Web site at http://www.meridian-audio.com/lib_apps.htm.

Resetting the DVD player

This chapter explains how to reset the DVD player using the front-panel controls.

Resetting the product

The DVD player provides several alternative standard settings, called Types, which configure all aspects of the product into the most commonly needed configurations.

Choosing one of the Types overrides any other configuration you may have performed, and so can be used to reset the configuration of the unit.

To reset the configuration

- If necessary press **On/Off** to put the DVD player into standby.
- Press **More**.

The display shows:



```
Version                               Reset
```

- Press **Reset**.

The display shows:



```
Reset Player
Exit          Yes
```

- Press **Yes** to reset the DVD player settings.

The display shows the current Type:



```
Type 1
Exit          ▼ ▲
```

- Press **▲** or **▼** to step through the available Types.

A description of each Type is shown on the top line of the display.
As you select each Type the DVD player is reset to that Type.

When you have selected the Type you want:

- Press **Exit** or **On/Off** to return to standby.

Types

The Types configure the DVD player in the appropriate way according to the other equipment you are connecting it to, and whether it is performing video switching, as shown in the following table:

Type	To connect to this	Video switching	See page
Type 0 (G91 only)	2-channel analogue amplifier.	Yes.	12
Type 1	2-channel DSP loudspeakers.	Yes.	11
Type 2	Surround processor not multichannel or 96kHz-capable.	Yes.	14
Type 3	Multichannel processor.	Yes.	20
Type 4	Multichannel processor.	In surround controller.	21
Type 5	Multichannel processor.	No.	14
Type 6 (G91 only)	Directly to loudspeakers in a surround system.	Yes.	15

Configuring the DVD player

This chapter explains how to configure the DVD player using the on-screen **Setup** menus. Alternatively, for complete control over all aspects of the product's configuration you can set up the unit from a computer using the Meridian Configuration Program. For full information refer to the *Meridian Configuration Program Guide* available separately.

Configuration

The **Setup** menus allow you to configure the video, audio, sources, settings, or playback options of the DVD player.

To use the on-screen **Setup** menus you need to have a suitable display connected to an appropriate output on the DVD player; see *Video connections*, page 17.

To display the Setup menus

- If a disc is playing press **■**.
- Press **More** until the display shows:



- Press **Setup**.

The display then shows:



The main **Setup** menu will be displayed on the On-Screen Display:

To select an option from a menu

- Press ▼ or ▲ to highlight the option you want:



- Press **Enter** to select the option.

To return to the previous menu

- Press **Return**.

To exit from the Setup menus

- Press **Setup**.

Configuring the video

The **Video setup** menu lets you change the video settings of the DVD player.

- Highlight **Video setup...** in the **Setup** menu, and press **Enter**.

The **Video setup** menu will be displayed:



To specify your display format

You should set the **Display aspect** option to the format that your display can accommodate.

Select 16:9 if you have a widescreen display, or an external processor for picture formats.

If you have a standard 4:3 television you also have the choice of displaying widescreen pictures cropped to fill your television screen (pan-scan), or with black bars above and below the picture (letterbox).

- Highlight **Display aspect** in the **Video setup** menu, and press **Enter**.

The **Display aspect ratio** menu is displayed:



- Press **▼** or **▲** to specify the format of your TV, and press **Enter**.

Note: The pan-scan feature is not available on some discs, in which case letterbox format will be used.

To select the black level for NTSC

- Highlight **Black level** in the **Video setup** menu, and press **Enter**.

The **Black level** menu is displayed:



- Press **▼** or **▲** to highlight the appropriate option, and press **Enter**.

If you are using the composite or S-video outputs of the DVD player select the **7.5 IRE** option.

If you are using the component outputs select the option that matches your display.

If you are using the DVD player to play both NTSC and PAL material the recommended setting is **0 IRE**.

This setting has no effect on the HDMI output.

To select closed caption subtitles

Some DVD-Videos include closed caption subtitles, which provide a description of sound effects for the hard of hearing; for example "door creaks".

- Highlight **Closed caption** in the **Video setup** menu, and press **Enter**.

The **Closed captions** menu is displayed:



- Press **▼** or **▲** to highlight **On** or **Off**, and press **Enter**.

To select the TV standard

DVD-Video discs are produced in both PAL and NTSC television formats. The DVD player is capable of converting between formats, to allow you to view DVD movies in either format even if your television is not capable of displaying that format. However the conversion process introduces some picture degradation, and may disable disc menu operation on some discs.

- Highlight **TV standard** in the **Video setup** menu, and press **Enter**.

The **TV standard** menu is displayed:

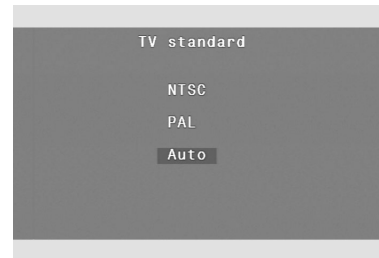

- Press **▼** or **▲** to highlight the option you want, and press **Enter**.

Choose **Auto** if your television can display both PAL and NTSC video, or choose **NTSC** or **PAL** to match the format supported by your television.

If your television is capable of displaying both formats the recommended setting is **Auto**, which supplies the unconverted video signal to the television.

To select the power up TV standard

A separate **Powerup std** option lets you specify the standard to be selected when you bring the DVD player out of standby:

- Highlight **Powerup std** in the **Video setup** menu, and press **Enter**.

The **Power up TV Standard** menu is displayed:

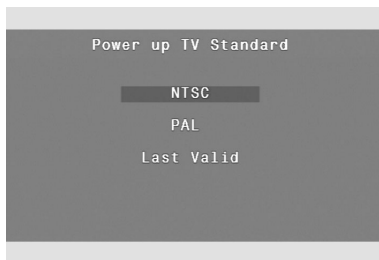

- Press ▼ or ▲ to highlight the option you want, and press **Enter**.

To select the screensaver options

- Highlight **Screensaver...** in the **Video setup** menu, and press **Enter**.

The **Screensaver options** menu is displayed:

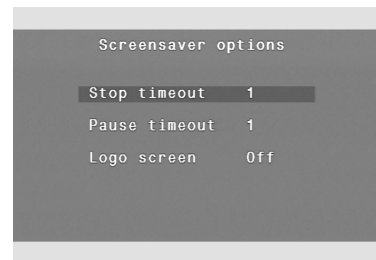

These options allow you to ensure that a static image does not remain on the display, thus avoiding damage to certain types of display.

The **Stop timeout** automatically fades the screen to black if the DVD player is left in stop mode and no key is pressed for the specified time.

The **Pause timeout** automatically switches the DVD player from pause into stop mode if no key is pressed for the specified time.

- Highlight **Stop timeout** or **Pause timeout** in the **Screensaver options** menu, and press **Enter**.

The appropriate menu is displayed:



- Press **▼** or **▲** to select the timeout delay, and press **Enter**.

You can also adjust the intensity of the logo screen, which is displayed as a background image when no video disc is playing and the DVD player is not in screensaver mode.

- Highlight **Logo screen** in the **Screensaver options** menu, and press **Enter**.

The **Logo screen intensity** menu allows you to select between **High**, **Low** or **Off**:

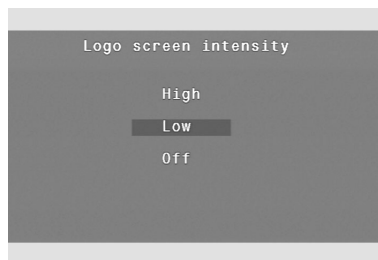

To set the scaler options

These specify how the interlaced video signal from the DVD should be upconverted to the HDMI and component outputs.

- Highlight **Scaler setup...** in the **Video setup** menu, and press **Enter**.

The **Scaler setup** menu is displayed:

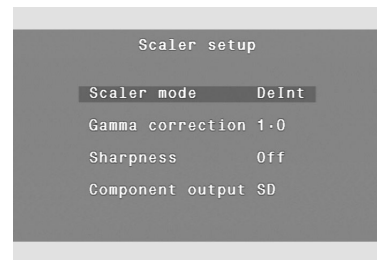

- Press **▲** or **▼** to highlight the setting you want to change, and press **Enter**.

The **Scaler mode** options are explained in the following table:

Scaler Mode	Description
Deinterlace	Converts 480i (NTSC) to 480p and 576i (PAL) to 576p.
720p	Upconverts to High Definition standard 720p progressive video.
1080i	Upconverts to High Definition standard 1080i interlaced video.
Auto	Automatically selects the best resolution for the display device connected to the HDMI connector.

The **Gamma correction** affects the grey scale, and can be set to **1.0**, **0.8**, **0.9**, or **1.1**. If the picture has poor detail in the dark areas choose a **Gamma correction** below 1.0. If the picture has poor detail in the light areas choose a **Gamma correction** greater than 1.0.

The **Sharpness** can be set to **Off**, **Low**, **Medium**, or **High**. It adds edge detail, but can cause picture artefacts.

Gamma correction and **Sharpness** only affect the analogue outputs.

Component output allows you to choose what is available on the component output socket. **Standard Definition** gives an SD interlaced component signal. **Scaled** gives a deinterlaced signal; for this option the **Scaler mode** should be set to **Deinterlace**.

To set the HDMI options

- Highlight **HDMI options...** in the **Video setup** menu, and press **Enter**.

The **HDMI setup** menu is displayed:



- Press **▲** or **▼** to highlight the setting you want to change, and press **Enter**.

The **DVI mode** can be set **DVI** or **HDMI**. Only choose **DVI** if you are connecting to a DVI input using a suitable adaptor cable.

The **Colour space** can be set to **RGB** or **YCrCb**.

Meridian Comms determines whether Meridian Comms is supplied on the HDMI cable, and can be set to **No** or **Yes**.

The **Audio source** option only appears on the G91 and allows you to specify the source of the audio on the HDMI connector. **Preamp** takes it from the DVD player preamplifier output, and **Transport** takes it direct from the DVD audio.

Configuring the audio

The **Audio setup** menu lets you select the audio settings of the DVD player.

- Highlight **Audio setup...** in the **Setup** menu, and press **Enter**.

The **Audio setup** menu will be displayed:

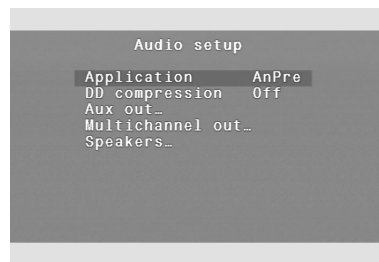

The **Speakers...** option only appears on the G91.

DVD player application

The options on the **Application** menu allow you to configure the audio outputs for optimum performance, depending on the capabilities of the equipment you are connecting to. For more information about the applications see *Applications*, page 11.

- Highlight **Application** in the **Audio setup** menu, and press **Enter**.

The **Application** menu is displayed. The options are different for the G91 and G98.

To specify the application for the G91

On the G91 the **Application** menu provides five options:

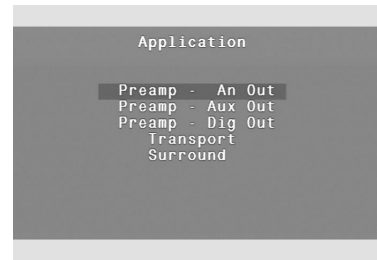

These are explained in the following table:

Select this option	For this application
Preamp – An Out (Type 0)	To use the DVD player as a preamplifier, connected via the analogue outputs to a power amplifier or analogue active speakers. All the other Application options provide fixed analogue outputs.
Preamp – Aux Out	To use the DVD player as a preamplifier, connected via the AUX DIGITAL output to a pair of DSP loudspeakers or a digital surround controller.
Preamp – Dig Out (Type 1)	To use the DVD player as a preamplifier, connected via the L/R MAIN DIGITAL output to a pair of DSP loudspeakers or a digital surround controller.
Transport (Type 3/4/5)	To connect the DVD player to the multichannel inputs of a Meridian digital surround controller via the L/R, C/LFE, and SURR MAIN DIGITAL outputs.
Surround (Type 6)	To connect the DVD player LR, C/LFE, and SURR MAIN DIGITAL outputs directly to DSP loudspeakers.

To specify the application for the G98

On the G98 the **Application** menu provides three options:

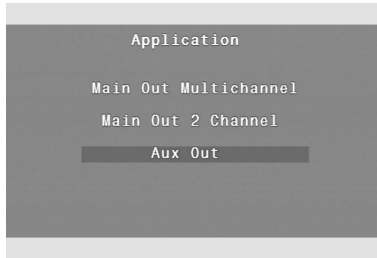

These are explained in the following table:

Select this option	For this application
Main Out Multichannel	To connect the DVD player to the multichannel inputs of a Meridian digital surround controller via the L/R, C/ LFE, and SURR MAIN DIGITAL outputs.
Main Out 2 Channel	To connect the DVD player via the L/R MAIN DIGITAL output to a pair of DSP loudspeakers or a digital surround controller.
Aux Out	To connect the DVD player via the AUX DIGITAL output to a pair of DSP loudspeakers or a digital surround controller.

To specify Dolby Digital compression

This option is useful for reducing the dynamic range of Dolby Digital soundtracks, such as when watching a film late at night.

It is only available on the decoded output.

- Highlight **DD compression** in the **Audio setup** menu, and press **Enter**.

The following menu is displayed:

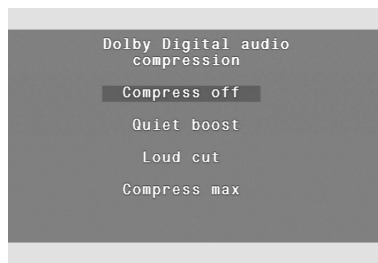

- Press **▼** or **▲** to select the option you want, and press **Enter**.

Choose **Compress off** for no Dolby Digital audio compression, **Quiet boost** to increase the level of quiet passages, **Loud cut** to reduce the level of loud passages, or **Compress max** for both low boost and high cut.

Auxiliary output settings**To specify the auxiliary output settings**

- Highlight **Aux out...** in the **Audio setup** menu, and press **Enter**.

The **Aux out** menu will be displayed:

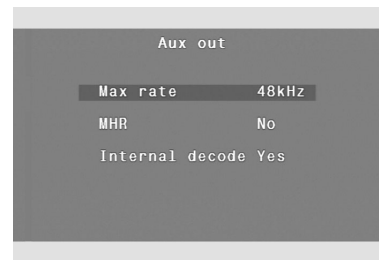
**To specify the maximum sampling rate for the auxiliary output**

This option allows you to specify the maximum sampling rate that the equipment connected to the auxiliary digital output can accept.

- Highlight **Max rate** in the **Aux out** menu, and press **Enter**.

The following menu is displayed:

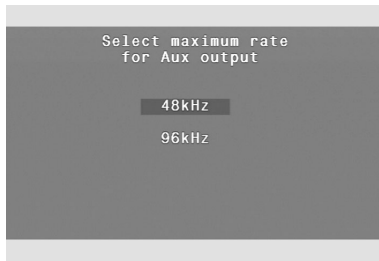

- Press ▼ or ▲ to choose between **48kHz** and **96kHz**, and press **Enter**.

When playing audio at higher rates it will be downsampled to the rate you have specified.

To select Meridian High Resolution on the auxiliary output

Meridian High Resolution is a proprietary format using encryption and anti-copy methods that allows secure transfer of audio streams between elements of a Meridian-only system for the purpose of playback only. It provides a secure copyright protection environment and has the very important benefit of lowering jitter and improving sound quality on all material.

- Highlight **MHR** in the **Aux out** menu, and press **Enter**.

The following menu is displayed:

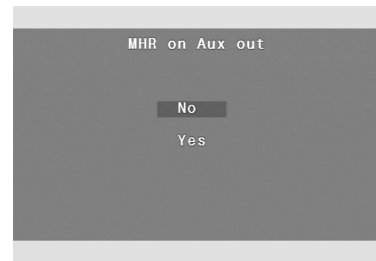

- Press ▼ or ▲ to select **No** or **Yes**, and press **Enter**.

If you are connecting the Aux output to a Meridian product that is MHR compliant, such as DSP loudspeakers, select **Yes**; otherwise select **No**.

To select internal decoding on the auxiliary output

- Highlight **Internal decode** on the **Aux out** menu, and press **Enter**.

The following menu is displayed:



- Choose **No** if you are connecting the AUX output to a Meridian digital surround controller.

Multichannel output settings

To specify the multichannel output settings

- Highlight **Multichannel out...** in the **Audio setup** menu, and press **Enter**.

The **Multichannel out** menu will be displayed:

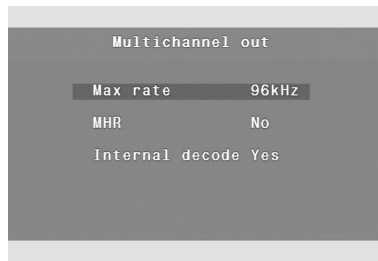

To specify the maximum sampling rate

This option allows you to specify the maximum sampling rate that the equipment connected to the main outputs can accept.

- Highlight **Max rate** in the **Multichannel out** menu, and press **Enter**.

The following menu is displayed:

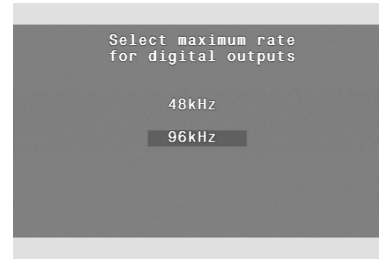

- Press **▼** or **▲** to choose between **48kHz** and **96kHz**, and press **Enter**.

Choose the appropriate rate for the product your DVD player is connected to.

When playing audio at higher rates it will be downsampled to the rate you specified. In the G91 audio at lower rates will be upsampled to the rate you specified.

To select Meridian High Resolution on the multichannel output

- Highlight **MHR** in the **Multichannel out** menu, and press **Enter**.

The following menu is displayed:



- Press ▼ or ▲ to select **No** or **Yes**, and press **Enter**.

If you are connecting the multichannel output to a Meridian product that is MHR compliant, such as the G68, select **Yes** to take advantage of MHR; otherwise select **No**.

To select internal decoding for the multichannel output

- Highlight **Internal decode** in the **Multichannel out** menu, and press **Enter**.

The following menu is displayed:



- Choose **Yes** if you are connecting the multichannel outputs to a Meridian digital surround controller.

To configure speakers (G91 only)

If you are using the G91 in a surround application, directly connected to DSP loudspeakers and up to two analogue speakers, the **Speakers** menu allows you to configure the speaker layout and enter calibration settings.

- Highlight **Speakers...** in the **Audio setup** menu, and press **Enter**.

The **Speakers** menu will be displayed:

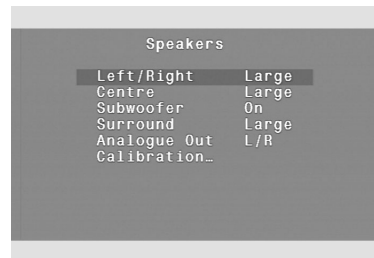

The options are summarised in the following table:

Option	Values	Description
Left/Right	Small, Large	Whether the main left and right loudspeakers should handle the bass (Large).
Centre	Off, Small, Large	Whether there is a centre loudspeaker, and its bass handling.
Subwoofer	Off, On	Whether there is a subwoofer.
Surround	Off, Small, Large	Whether there are rear surround speakers, and their bass handling.
Analogue Out	None, Sub, Centre, Centre/Sub, Left/Right, Surround	Whether the analogue outputs are used to drive one or two analogue speakers, and if so, their positions.
Calibration...		See below.

To calibrate the speaker layout (G91 only)

- Highlight **Calibration...** in the **Speakers** menu, and press **Enter**.

The **Calibration** menu will be displayed:

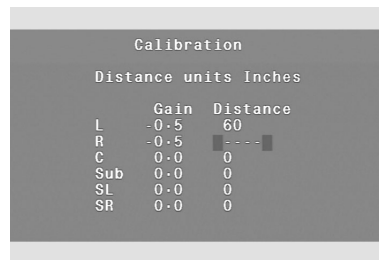

- Highlight **Distance units** and press **Enter** to change the distance units between cm and inches.

Then for each speaker adjust the **Gain** and **Distance** as follows:

- Press **▼** to highlight the **Gain** figure and press **Enter** to edit it.

You will hear a noise test signal from the corresponding channel.

- Press **▼** or **▲** to decrease or increase the gain in 0.5 dB steps, and press **Enter** to confirm it.

Adjust the **Gain** values so all the speakers sound equally loud at the listening position.

- Press **▼** to highlight the **Distance** figure and press **Enter** to edit it.

- Measure the distance from the listening position to the speaker and enter the value using the **▼** or **▲** keys, or the MSR+ number keys, and press **Enter** to confirm it.

- Press **Return** when you have entered the values for all the speakers.

Configuring the sources

If you are using the DVD player as the controller or video switcher in your Meridian system, you can use the **Source config** option on the **Setup** menu to configure each of the sources.

- Highlight **Source config...** in the **Setup** menu, and press **Enter**.

The **Source configuration** menu will be displayed:

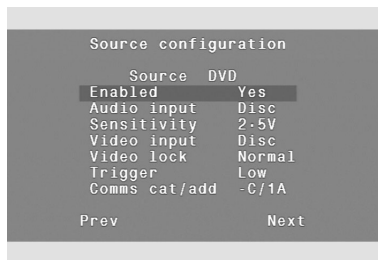

To configure a source

- Press the source key on the remote corresponding to the source you want to configure.

The **Source configuration** menu shows the values of each option defined for that source.

To change an option

- Highlight the corresponding option in the **Source configuration** menu and press **Enter**, select the value you want to use, and press **Enter** to select it.

The following table explains the function of each of the options:

Option	Values	Description
Enabled	Yes, No	Whether the source appears on the list of sources.
Audio input (G91 only)	A1-A3, D1-D2, O1-O2, Disc, Tuner	The audio input used for the source; analogue, digital, optical, and internal.
Sensitivity (G91 only)	2.5V, 2.0V, 1.0V, 0.5V	Allows you to set the sensitivity of the analogue inputs.
Video input	V1-V2, S1-S3, Y1, Bypass, Disc	Video input used for the source.
Video lock	Normal, Poor	Improves locking for poor video sources
Trigger	High, Low	Trigger output for the source.
Comms cat/add	-C, 1C-9C, NC/1A-8A	Allows you to set the Comms category and address.

To assign an audio input to the source (G91 only)

- Highlight **Audio input** in the **Source configuration** menu, and press **Enter**.

The **Select audio input** menu will be displayed:

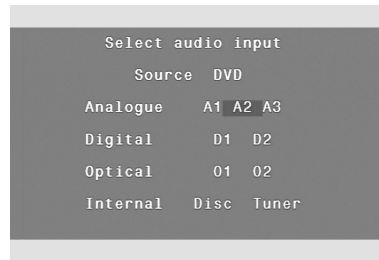

- Highlight the **Analogue**, **Digital**, **Optical**, or **Internal** input you want to use for the source, and press **Enter** to select it.

Disc corresponds to the internal DVD player and **Tuner** corresponds to the internal FM/AM tuner module (G91 only).

To assign a video input to the source

- Highlight **Video input** in the **Source configuration** menu, and press **Enter**.

The **Select video input** menu will be displayed:

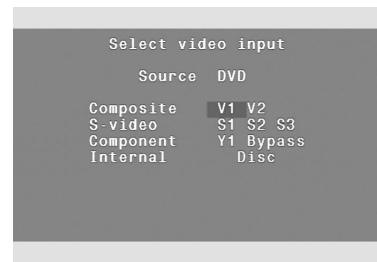

- Highlight the video input you want to use for the source, and press **Enter** to select it.

Select **Bypass** to route the component input directly to the component output, for sources such as satellite receivers and cable boxes that generate HD signals.

Disc corresponds to the internal DVD player.

Configuring settings

The **Meridian setup** menu allows you to configure settings that affect the operation of the DVD player.

To configure settings

- Highlight **Meridian setup...** in the **Setup** menu, and press **Enter**.

The **Meridian setup** menu will be displayed:



The product settings are generally set to an appropriate value when you reset the DVD player to the standard settings, and you should not normally need to alter them.

The options are summarised in the following table for advanced use:

Option	Values	Description
Diagnostics	Yes, No	Whether diagnostic displays are shown on the front-panel display.
System address	1-8	Advanced setting.
Product address	1-8	Advanced setting.
Controller	Yes, No, Auto	Whether the product is the infra-red controller for the system.
Start source	Source	Specifies which source is selected when switching on from standby.
Vol display	No, Yes	Specifies whether the DVD player displays the volume for the system.
Advanced OSD	Off, On	Shows playback statistics in the OSD bar.
Tuner Region (G91 only)	Europe, America	Band selection (MW/LW or AM) and the tuner deemphasis standard. Set to Europe for other countries.
Timeout To Home	Off, On	Sets a 30s timeout for the front-panel display to return to Home.

Configuring playback options

DVD-Video discs are capable of providing a wide range of options and special features. This chapter explains how to use the options on the **Setup** menu to configure the playback options of the G Series DVD player.

Setting playback options

To display the playback options

- Highlight **Playback options...** in the **Setup** menu, and press **Enter**.

The **Playback options** menu lets you change the default language for the audio soundtrack, subtitles, and on-screen menus, and the parental rating:

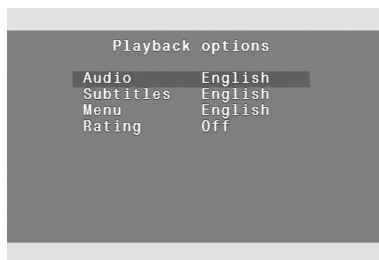

To select the default soundtrack language

Most DVD-Video discs include a selection of soundtrack languages. English is usually the default soundtrack language, but you can use the **Audio language** menu to set a different default language if you prefer.

- Highlight **Audio** in the **Playback options** menu, and press **Enter**.

The **Audio language** menu is displayed:



- Press ◀, ▶, ▲, or ▼ to highlight the default soundtrack language you want to use, or select **Original** to choose the original soundtrack language, and press **Enter**.

To set the default subtitle language

DVD-Video discs can include subtitles in up to 32 different languages.

The DVD player allows you to select whether subtitles are displayed by default, and specify the preferred language if it is available on the disc.

- Highlight **Subtitles** in the **Playback options** menu, and press **Enter**.

The **Subtitle language** menu is displayed:



- Press ◀, ▶, ▲, or ▼ to highlight the language you want to use, and press **Enter**.

Alternatively, select **Auto** to automatically display subtitles in the specified audio language if no soundtrack is available for that language.

To select the disc menu language

The DVD player allows you to choose the language for the disc menus.

- Highlight **Menu** in the **Playback options** menu and press **Enter**.

The **Menu language** menu is displayed:



- Use ◀, ▶, ▲, or ▼ to highlight the language you want to use, and press **Enter**.

To set the parental lock

Some DVD-Video discs are provided with a parental lock function to allow you to lock out playback of scenes whose content exceeds a specified rating until a password is entered.

- Highlight **Rating** in the **Playback options** menu and press **Enter**.

The **Enter password** screen is displayed:

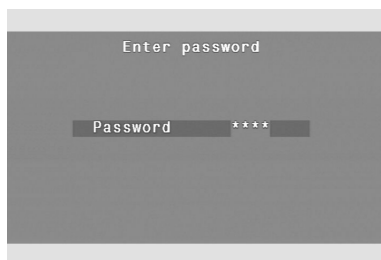

- Enter your four-digit password and press **Enter**.

Initially the password is set to 7890, but you can change it to any password you choose as described in *To change the password*, page 48.

The following screen then allows you to set the rating level:



- Press ▲ or ▼ to highlight the rating level you want to set, or highlight **Off** to turn the parental lock off, and press **Enter** to select it.

Level 1 corresponds to general viewing, level 3 is equivalent to the USA movie rating PG, and level 8 corresponds to adult viewing.

The rating level you have set will be displayed in the **Playback options** menu.

To change the password

- Highlight **Change password** on the **Set rating level** screen and press **Enter** to select it.

The following screen allows you to specify the new password:

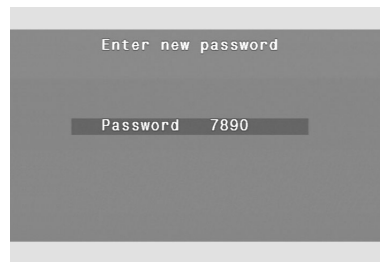

- Enter the four-digit password you want to use and press **Enter** to select it. The password cannot start with a zero.

Take care not to forget your password, or you will need to contact your Meridian dealer to reset it for you.

Region codes

For commercial reasons many DVDs are encoded with one or more region codes to identify the countries in which they can be used. Every DVD player is assigned a region code to determine which discs it can play.

The different parts of the world are divided into regions 1 to 6 as shown in the following diagram:

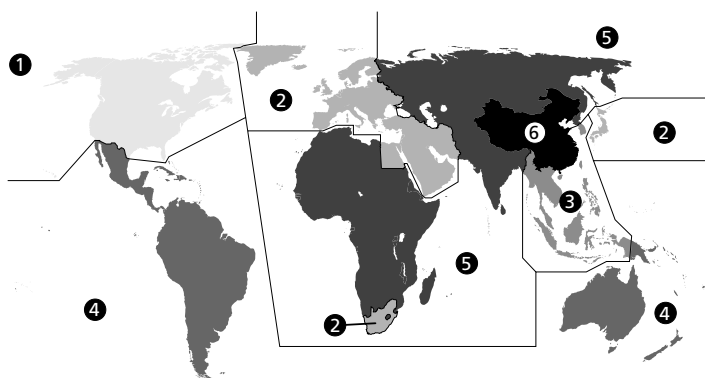

- 1 – USA, Canada
- 2 – Europe, Near East, South Africa, Japan
- 3 – South East Asia
- 4 – Australia, Central & South America
- 5 – Africa, Asia, Eastern Europe
- 6 – People's Republic of China

If you try to play a disc which is assigned to the incorrect region code then either a special screen or the warning **WRONG REGION CODE** will be displayed.

The **Information** screen shows the region code, and other information which depends on the product version:

To change your DVD player's region code please contact your dealer.

To check your DVD player region code

- Highlight **Information...** in the **Setup** menu, and press **Enter** to select it.

```

Information
Region code  1
Firmware    1.0
Compiled    06-08-03
Microcode   W-2411
Drive DVS-LDR DSL-720A
Drive code  LV16
DSP1 code   10
DSP2 code   50
Exit
  
```

Video controls

The G Series DVD players include several video controls to allow you to adjust the video image. The video controls are available for video sources, and the picture position controls are also available for the internal DVD.

Note: The menus do not appear unless you have a locked video input.

To display the video controls

Either:

- Press **More** until **Video** is displayed.
- Press **Video**.

Or:

- Press the red key on the MSR+.

If you have reprogrammed the MSR+ you may need to press **Function DVD** first.

The display shows the first video control, horizontal and vertical picture position:



- Press ◀ or ▶ to change the horizontal picture position, and ▲ or ▼ to change the vertical picture position.

Each control can be varied between -30 and 30.

- Press **Video** or the red key on the MSR+ to show the next video control.

The following table shows the full list of video controls:

Display	Description
X=, Y=	Horizontal and vertical picture position.
Black*	Black level.
Contrast*	Picture contrast.
Colour*	Picture colour.
Hue*	Picture hue (NTSC inputs only).

* Only for external video sources.

Troubleshooting

We expect you to achieve superb results with the DVD player. If, however, you encounter any problems, either when installing and configuring it, or during operation, please check the following pages for suggested solutions.

If these suggestions fail to cure the problem, please contact your Meridian dealer for further assistance.

General operating problems

The DVD player will not play a particular disc

Although we have made every effort to ensure complete compatibility with all supported disc types, it is impossible to check the correct operation of every function of the G Series DVD players with every available disc; furthermore, some discs currently on sale do not conform to the agreed format specifications. We cannot therefore accept any responsibility for discs that will not play correctly, even if they play correctly on other brands of player.

- The disc may be scratched or faulty. Examine it for damage, and try playing it on another product.
- There are several Web sites that give details of discs with known playback problems. Please check these to see if your disc is listed.

No lights are displayed when switching on

- Check that the AC power supply is connected correctly.
- Check that the **ON OFF** switch on the back panel is in the **ON** position.
- Press **Display** to check that the display is not blank.

A question-mark symbol is displayed on the on-screen display

This indicates that the function you have selected is not currently available on the disc you are playing.

The on-screen display shows WRONG REGION CODE

This indicates that you are attempting to play a DVD-Video disc encoded for a region that is not supported by your DVD player.

The DVD player unexpectedly switches from pause to stop, or fades the screen to black

This is caused by the pause or stop timeouts.

The pause timeout automatically switches the DVD player from pause into stop mode if no key has been pressed for the specified time.

The stop timeout automatically fades the screen to black if the DVD player is left in stop mode and no key has been pressed for the specified time.

The on-screen display shows PLEASE CHECK DISC when attempting to play a disc

- Check that the disc is positioned correctly in the tray.
- If it is a single-sided disc check that the label is uppermost.
- Check that the disc is clean and free of debris.
- Try playing another disc. If this disc works, check the problem disc for signs of dirt or damage.

There is interference on the radio and/or television when the DVD player is switched on

Before following the steps below, ensure all units are switched off.

If this equipment does cause or suffer from interference to/from radio or television reception then the following measures should be tried:

- Reorient the receiving aerial (or antenna) or route the antenna cable of the receiver as far as possible from the DVD player and its cabling.

- Ensure that the receiver uses well-screened antenna cable.
- Relocate the receiver with respect to the DVD player.
- Connect the receiver and this product to different AC outlets.

Audio problems

There is no sound when playing a disc

- Check that your preamplifier is switched on, and the volume is at an appropriate level.
- Check that the DVD player is connected correctly to the other components of your system; see *Installing the DVD player*, page 7.
- Check that the correct source has been selected on your preamplifier.
- Try playing another disc. If this disc works, check the problem disc for signs of dirt or damage.
- Check that the correct option has been selected in the **Application** menu; see *DVD player application*, page 34.

Video problems

There is no picture

The G Series DVD players include video switching, so each source can be associated with a video input or the internal DVD.

- Select the DVD source.

To associate the internal DVD with another source see *Configuring the sources*, page 41.

Problems with high definition television sets

Not all high definition television sets are fully compatible with this product and may cause artifacts to be displayed in the picture. In case of problems switch to the standard definition output.

The video picture is monochrome

Check your video cabling.

Problems with HDMI

For more information about HDMI see the **Library: Application Notes** section of the Meridian Web site at http://www.meridian-audio.com/lib_apps.htm.

Radio tuner problems

FM tuner reception is poor

To obtain high-quality stereo reception on FM a good aerial is essential. Try positioning the aerial at different points in a room; generally performance is best high up and near a window.

In some areas an external fixed aerial will be necessary. This can be placed in a loft or mounted externally.

AM tuner reception is poor

Position the antenna to maximise the strength of the station you want to receive and to reduce interference from other stations on nearby frequencies.

Position the antenna away from items that generate electrical interference, such as fluorescent tubes or televisions.

RDS station names are not being received

Not all stations transmit the station name in all areas, and RDS will only be received if the signal strength is good.

If the station name is not available you can define a preset station with a name; see the *G Series System Guide*.

Creating MP3 discs

MP3 discs can be created from a computer using appropriate MP3 encoding software and a CD-ROM writer.

Generate the MP3 files with a data rate of at least 128kbps per second. Group the tracks into folders to create separate albums on the disc. Do not create folders within the folders.

Tracks and albums are played in the order in which they are recorded onto the CD-ROM. Usually this will be in alphabetical order of filename. To determine the playing order prefix the track and album names with 01, 02, 03 etc, and sort the list into alphabetical order before making the CD-ROM.

If artist and album names are stored in each file's ID3 tags, these can be displayed on the DVD player's front-panel display.

Maintenance

Cleaning

To clean the case, display panel, and keypad

- Disconnect the power cord before cleaning the unit.

The exterior surfaces of Meridian G Series products are made from solid anodised aluminium, powder coated steel, thermoplastic rubber, and glass.

They are designed to be easily wiped clean with a dry, lint free cloth. Greasy marks should be removed by light rubbing with a slightly damp cloth and a trace of proprietary glass cleaner. Do not use any other solvent or abrasive based cleaners. Dust can be removed from the disc drive tray with a small dry brush when the drawer is open.

Ensure that no liquid enters the casework and that the product is completely dry before re-connection.

To clean the audio and video connections

The audio and video sockets on the back of the product are gold plated and do not need to be cleaned if gold-plated phono plugs are used. Otherwise, it is recommended that you unplug and reconnect the plugs at least once a year. A proprietary contact cleaner can be used to some advantage.

The electrical digital output should be treated in a similar way.

To change the mains fuse

- Remove the mains connector, and pull out the drawer above the power input to access the fuse.

Before replacing a blown fuse, it is best to ascertain the cause of the failure.

The fuse drawer includes a spare fuse. This should be replaced by a fuse of the same rating.

Service and guarantee

Service

The Meridian G Series of hi-fi components has been carefully designed to give years of untroubled service. There are no user-serviceable parts inside the case, nor do the units require any form of maintenance.

In the unlikely event that your product fails to function correctly, it should be returned, in its original packaging, to your Meridian dealer.

In case of difficulty within the UK or USA please contact the appropriate sales and service address shown on page iv.

In case of difficulty outside the UK or USA, contact the importing agent for the territory. A list of Meridian agents outside the UK is available from Meridian Audio.

No responsibility can be accepted for the product whilst in transit to the factory or an agent, and customers are therefore advised to insure the unit. When seeking service under guarantee, proof of the date of purchase will be required.

Guarantee

The product is guaranteed against defects in material and workmanship for two years from the date of purchase.

The guarantee is void if the product has been subject to misuse, accident, or negligence, or has been tampered with or modified in any way without the written authorisation of Meridian Audio Limited. **Note:** Connecting anything other than the correct network lead to the Comms sockets may cause damage to the product which will not be covered by this guarantee. Attempted servicing by unauthorised people may also invalidate this guarantee. Labour and carriage charges are not covered unless by local agreement.

Outside the UK, local warranty liability is restricted to equipment purchased within the territory. Our agents outside the UK are only under contractual obligation to service under-guarantee equipment sold through them. They are entitled to make a non-refundable charge for any service carried out on other equipment.

This guarantee does not limit your statutory rights within the country of purchase.

A

accessories 7
analogue outputs 9
antennae, connecting 24
Application menu 34
audio connections
 analogue outputs 9
 digital outputs 8
Audio setup menu 34
automatic setup 23
auxiliary output
 internal decoding, selecting 37
 Meridian High Resolution, selecting 37
 settings 36

B

black level, changing 50
black level (NTSC), selecting 29

C

cleaning 54
closed caption subtitles, selecting 30
colour, changing 50
COMMS, connecting 23
component video, connecting 18
composite video, connecting 19
connections
 cleaning 54
 communications 22

connections (*continued*)

 preamplifier 10
 tuner (G91 only) 10
 video 17
contrast, changing 50
Controller, setting 23

D

default soundtrack language, selecting 45
default subtitle language, setting 46
digital outputs 8
disc menu language, selecting 46
display format, specifying 29
Dolby Digital compression, specifying 36
DVI, connecting to 19, 33

G

G68 Digital Surround Controller, connecting 20
 video switching in the G68 21
 video switching in the G98 20
G91 1, 2
 audio connections 8
 audio input, assigning 42
 communications connections 22
 preamplifier connections 10
 speakers, configuring 39
 speaker layout, calibrating 40
 specifications 6
 surround system 15

G91 (*continued*)

- tuner connections 10, 22

- video connections 17

G98AH 1, 2

- audio connections 9

- communications connections 22

- specifications 6

- video connections 17

G98DH 1, 2

- audio connections 8

- communications connections 22

- specifications 6

- video connections 17

guarantee 55

H

HDMI options 33

- connecting to a monitor 19

horizontal picture position, changing 50

hue, changing 50

M

mains fuse, changing 54

maximum sampling rate 38

- auxiliary output 36

- multichannel output 38

menu navigation 28

Meridian DSP loudspeakers, connecting to 11

Meridian High Resolution, selecting

- auxiliary output 37

- multichannel output 38

Meridian setup menu 43

MP3 discs 53

multichannel output

- internal decoding, selecting 39

- maximum sampling rate, selecting 38

- Meridian High Resolution, selecting 38

- settings 38

P

parental lock, setting 47

password, changing 48

Playback options menu 45

preamplifier connections 10

product, resetting 25

R

region codes 49

resetting the configuration 25

S

S-video, connecting 18

safety warnings ii

scaler options 32

screensaver options 31

Setup menu 45

setup menus, displaying 27

sources

audio inputs, assigning 42

configuring 41

video inputs, assigning 42

Source configuration menu 41

speakers, configuring (G91 only) 39

speaker layout, calibrating (G91 only) 40

specifications 6

surround processor, connecting to 13, 14

surround system

calibrating 40

creating 15

T

troubleshooting 51

tuner connections 10

TV standard, selecting 30

power up 31

two-channel analogue, connecting to 12

Types 25, 26

V

vertical picture position, changing 50

video connections 17

video controls 50

Video setup menu 29

60

Index