

Compaq Armada M300 Series of Personal Computers

Maintenance and Service Guide

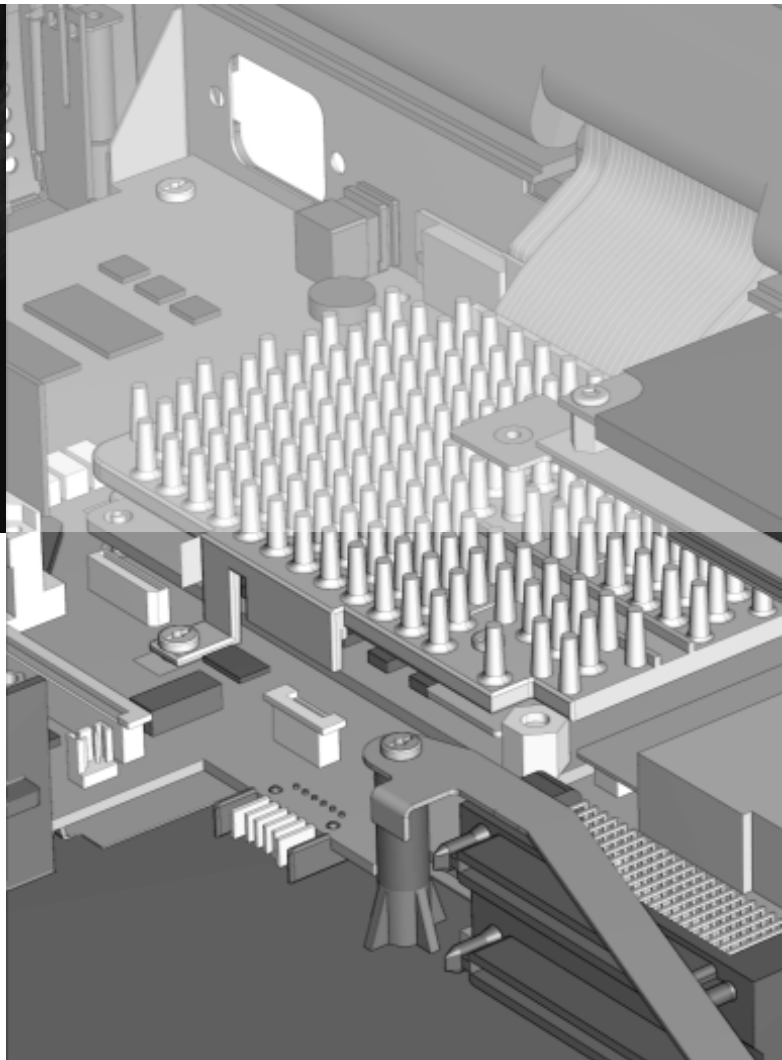
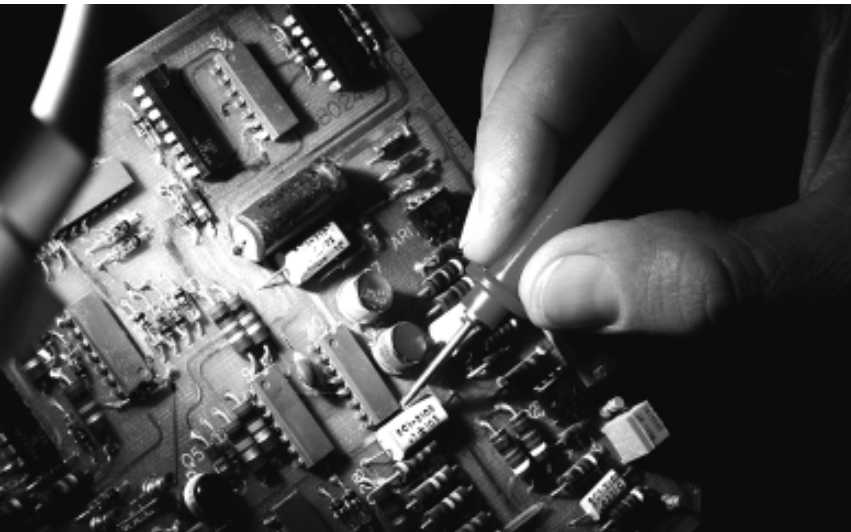

COMPAQ

DOCUMENTATION SURVEY

Does the *Maintenance and Service Guide* contain all needed information? Yes No

If not, what additional information would you like to see in the guide?

Is the guide easy to use? Yes No If not, please explain: _____

Is the artwork easy to interpret? Yes No If not, please explain: _____

What information in the guide do you use most frequently? _____

What information do you use least? _____

How often do you refer to the *Maintenance and Service Guide*? _____

In what form would you prefer to receive information? (Rank 1 to 5, with 1 representing the most preferred.)

- _____ *Maintenance and Service Guide* on CD-ROM
- _____ *Maintenance and Service Guide* on Compaq Web site
- _____ *Maintenance and Service Guide* on QuickFind
- _____ Printed *Maintenance and Service Guide*
- _____ A combination of the above (please specify)

How do you receive *Maintenance and Service Guides*? _____

Is the guide available in a timely manner (when you need it)? Yes No If not, please explain:

Are sufficient quantities of the *Maintenance and Service Guide* available? Yes No If not, please explain:

Additional Documentation Comments: _____

Name: _____ Phone: _____

Job Title: _____ Company: _____

Address: _____

City: _____ State: _____ Zip: _____

Notice

© 2000 Compaq Computer Corporation.

COMPAQ, the Compaq logo, and ARMADA Registered in U. S. Patent and Trademark Office

Microsoft, Windows, Windows NT, are registered trademarks of Microsoft Corporation in the United States and/or other countries. Intel and Pentium are registered trademarks of Intel Corporation in the United States and other countries.

All other product names mentioned herein may be trademarks or registered trademarks of their respective companies.

Compaq shall not be liable for technical or editorial errors or omissions contained herein. The information in this document is subject to change without notice and is provided “as is” without warranty of any kind. The entire risk arising out of the use of this information remains with the recipient. In no event shall Compaq be liable for any direct, consequential, incidental, special, punitive, or other damages whatsoever (including without limitation, damages for loss of business profits, business interruption, or loss of business information), even if Compaq has been advised of the possibility of such damages. The limited warranties for Compaq products are exclusively set forth in the documentation accompanying such products. Nothing herein should be construed as constituting a further or additional warranty.

MAINTENANCE AND SERVICE GUIDE

Compaq Armada M300 Series of Personal Computers

Second Edition February 2000

First Edition July 1999

Published in the U.S.A., U.K., Singapore, and Taiwan.

Documentation Part Number 113732-002

Spare Part Number 158339-001

CONTENTS

preface

USING THIS GUIDE	VII
-------------------------------	-----

chapter 1

PRODUCT DESCRIPTION

1.1 Computer Features and Models	1-1
Models	1-2
Features	1-4
Intelligent Manageability	1-5
Accessing the Web Agent	1-5
Asset Management	1-5
Fault Management	1-6
Fault Management Alerts	1-6
Security Management	1-6
Configuration Management	1-7
Managing Power	1-7
Accessing Power Management	1-7
Power Management Levels	1-7
1.2 Computer External Components	1-8
1.3 Design Overview	1-15
System Board	1-15

chapter 2

TROUBLESHOOTING

2.1 Preliminary Steps	2-2
2.2 Clearing Passwords	2-3
2.3 Power-On Self-Test (POST)	2-3
2.4 POST Error Messages	2-4
2.5 Compaq Utilities	2-6
2.6 Troubleshooting Without Diagnostics	2-12
Before Replacing Parts	2-12
Obtaining Update Information with Info messenger	2-12
Checklist for Solving Problems	2-13

chapter 3

ILLUSTRATED PARTS CATALOG

3.1 Serial Number Location	3-1
3.2 Computer Major System Components	3-2
3.3 Miscellaneous Plastic Kit Components	3-4
3.4 Mass Storage Devices	3-5
3.5 Miscellaneous	3-6

chapter 4

REMOVAL AND REPLACEMENT PRELIMINARIES

4.1 Tools Required.....	1-1
4.2 Service Considerations.....	1-1
Plastic Parts	4-1
Cables and Connectors.....	4-2
4.3 Preventing Damage to Removable Drives	1-2
4.4 Preventing Electrostatic Damage.....	1-3
Packaging and Transporting Precautions.....	4-3
Workstation Precautions	4-4
Grounding Equipment and Methods	4-5
Electrostatic Voltage Levels and Protective Materials.....	4-6

chapter 5

REMOVAL AND REPLACEMENT PROCEDURES

5.1 Serial Number	5-1
5.2 Disassembly Reference Chart.....	5-2
5.3 Disconnecting the Computer from the Mobile Expansion Unit	5-3
5.4 Disconnecting the Computer	5-4
5.5 Preparing the Computer for Disassembly	5-5
5.6 Battery Packs.....	5-6
Removing the Battery Pack.....	5-6
Replacing the Battery Pack.....	5-7
5.7 Hard Drives	5-8
Removing a Hard Drive	5-8
Inserting a Hard Drive.....	5-9
5.8 PC Cards	5-10
Removing a PC Card.....	5-11
Inserting a PC Card	5-12
5.9 Modem or Modem/NIC Card	5-13
5.10 Real Time Clock (RTC) Battery.....	5-15
5.11 Keyboard.....	5-16
5.12 Memory Expansion.....	5-18
Removing the Memory Expansion Board	5-18
Installing the Memory Expansion Board.....	5-19
5.13 Switch Cover.....	5-20
5.14 Display Assembly	5-22
5.15 Top Cover with TouchPad.....	5-23
5.16 Voltage Converter Board.....	5-25
5.17 Modem Connector Board.....	5-26
5.18 PC Card Assembly.....	5-28
5.19 System Board	5-29

chapter 6

SPECIFICATIONS

6.1 Physical and Environmental	6-1
6.2 Display	6-2
6.3 Hard Drive.....	6-3
6.4 Diskette Drive	6-4
6.5 Li-Ion Battery Pack.....	6-4
6.6 CD-ROM Drive	6-5
6.7 DVD-ROM Drive	6-6
6.8 System Interrupts	6-7
6.9 System DMA.....	6-7
6.10 System I/O Addresses.....	6-8
6.11 System Memory Map.....	6-9

appendix A

CONNECTOR PIN ASSIGNMENTS	A-1
--	------------

appendix B

POWER CORD SET REQUIREMENTS	B-1
--	------------

INDEX	I-1
--------------------	------------

preface

USING THIS GUIDE

This *Maintenance and Service Guide* is a troubleshooting reference that can be used when servicing the Compaq Armada M300 Series of Personal Computers.

Compaq Computer Corporation reserves the right to make changes to the Compaq Armada M300 Series of Personal Computers without notice.

Symbols

The following words and symbols mark special messages throughout this guide:



WARNING: Text set off in this manner indicates that failure to follow directions in the warning could result in bodily harm or loss of life.



CAUTION: Text set off in this manner indicates that failure to follow directions in the caution could result in damage to equipment or loss of information.

IMPORTANT: Text set off in this manner presents clarifying information or specific instructions.

NOTE: Text set off in this manner presents commentary, sidelights, or interesting points of information.

Technician Notes



WARNING: Only authorized technicians trained by Compaq should repair this equipment. All troubleshooting and repair procedures are detailed to allow only subassembly/module level repair. Because of the complexity of the individual boards and subassemblies, no one should attempt to make repairs at the component level or to make modifications to any printed wiring board. Improper repairs can create a safety hazard. Any indication of component replacement or printed wiring board modifications may void any warranty or exchange allowances.



WARNING: The computer is designed to be electrically grounded. To ensure proper operation, plug the AC power cord into a properly grounded electrical outlet only.



CAUTION: To properly ventilate the system, you must provide at least 3 inches (7.62 cm) of clearance on the left and right sides of the computer.

Serial Number

When requesting information or ordering spare parts, provide the computer serial number. The serial number is on the bottom of the computer.

Locating Additional Information

In addition to this guide, the following documentation provides information for the computer:

- Compaq Armada M300 Series of Personal Computers documentation set
- Microsoft Operating System Manual
- Compaq Service Training Guides
- Compaq Service Advisories and Bulletins
- *Compaq QuickFind*
- *Compaq Service Quick Reference Guide*
- Compaq Internet site at <http://www.Compaq.com>

chapter 1

PRODUCT DESCRIPTION

1.1 Computer Features and Models

The Compaq Armada M300 Series of Personal Computers is an ultralight 3.1 to 3.3 pound (1.4 to 1.5 kg) computer (depending on configuration). It allows users high mobility, provides a full set of system ports, and when paired with the optional Mobile Expansion Unit (MEU), transforms into a full-function portable with enterprise docking capability.



Figure 1-1. Compaq Armada M300 Personal Computer

Models

The Armada M300 models are shown in Table 1-1. The computer model designation is composed of a group of characters that define each model's features.

**Table 1-1
Models and Model Naming Convention
Compaq Armada M300 Series of Personal Computers**

Key																										
A	M	3		P3	500	T	1	X	12	0	M	128	58	N	S	F										
1	2	3	4	5-6	7-9	10	11	12	13-14	15	16	17-19	20-21	22	23	24										
Key	Description		Options																							
1	Brand designator		A = Armada																							
2	Segment designator		M = Mobility																							
3	Series		3 = 300																							
4	Blank																									
5-6	Processor type		P3 = Intel Pentium III processor with 256 KB cache				P2 = Intel Pentium II processor with 256 KB cache				C = Intel Celeron processor with 128 KB cache															
7-9	Processor speed		500 = 500 MHz				450 = 450 MHz				333 = 333 MHz															
10	Panel type		T = TFT																							
11	Panel size		1 = 11.x"																							
12	Panel resolution		X = XGA				S = SVGA																			
13-14	Hard drive size (in GB, 1-2 digits)		12 = 12.0 GB				6 = 6.4 GB				4 = 4.3 GB															
15	Optical drive		0 = none																							
16	Integrated communication		M = Mini PCI V.90 Modem				C = NIC/modem combination				0 = none															
17-19	RAM (in MB, 2-3 digits)		64 = 64 MB																							
20-21	Operating system		95 = Windows 95				98 = Windows 98				58 = Windows 95/98 dual install				N4 = Windows NT 4.0				N2 = Windows 2000				N4/N2 = Windows NT 4.0/2000 dual install			
22	NAFTA		N = NAFTA																							
23	Pointing device		P = TouchPad																							
24	Security																									

Table 1-2
Models and Model Naming Convention
Compaq Armada M700 Series of Personal Computers

1	2	3	4	5-6	7-9	10	11	12	13-14	15	16	17-19	20-21	22	23	24	SKU#
A	M	3		P3	500	T	1	X	12	0	C	128	58		P		165288-XX2
A	M	3		P3	500	T	1	X	12	0	C	128	N4/N2		P		165288-XX6
A	M	3		P3	500	T	1	S	12	0	0	64	58		P		152547-XX2
A	M	3		P3	500	T	1	S	12	0	0	64	N4/N2		P		152547-XX6
A	M	3		P3	500	T	1	S	12	0	M	64	58		P		152548-XX2
A	M	3		P3	500	T	1	S	12	0	M	64	N4/N2		P		152548-XX6
A	M	3		P3	500	T	1	S	12	0	C	64	58		P		152549-XX2
A	M	3		P3	500	T	1	S	12	0	C	64	N4/N2		P		152549-XX6
A	M	3		C	450	T	1	S	6	0	0	64	58		P		152544-XX2
A	M	3		C	450	T	1	S	6	0	0	64	N4/N2		P		152544-XX6
A	M	3		C	450	T	1	S	6	0	M	64	58		P		152545-XX2
A	M	3		C	450	T	1	S	6	0	M	64	N4/N2		P		152545-XX6
A	M	3		C	450	T	1	S	6	0	C	64	58		P		152546-XX2
A	M	3		C	450	T	1	S	6	0	C	64	N4/N2		P		152546-XX6
A	M	3		P2	333	T	1	S	6	0	C	64	95		P		138594-XX2
A	M	3		P2	333	T	1	S	6	0	C	64	98		P		138594-XX4
A	M	3		P2	333	T	1	S	6	0	C	64	N4		P		138594-XX6
A	M	3		C	333	T	1	S	4	0	C	64	95		P		138595-XX2
A	M	3		C	333	T	1	S	4	0	C	64	98		P		138595-XX4
A	M	3		C	333	T	1	S	4	0	C	64	N4		P		138595-XX6
A	M	3		P2	333	T	1	S	6	0	0	64	95		P		107008-XX2
A	M	3		P2	333	T	1	S	6	0	0	64	98		P		107031-XX4
A	M	3		P2	333	T	1	S	6	0	0	64	N4		P		107051-XX6
A	M	3		P2	333	T	1	S	6	0	M	64	95		P		107009-XX2
A	M	3		P2	333	T	1	S	6	0	M	64	98		P		107032-XX4
A	M	3		P2	333	T	1	S	6	0	M	64	N4		P		107052-XX6
A	M	3		C	333	T	1	S	4	0	0	64	95		P		107061-XX2
A	M	3		C	333	T	1	S	4	0	0	64	98		P		107062-XX4
A	M	3		C	333	T	1	S	4	0	0	64	N4		P		107067-XX6
A	M	3		C	333	T	1	S	4	0	M	64	95		P		124788-XX2
A	M	3		C	333	T	1	S	4	0	M	64	98		P		124789-XX4
A	M	3		C	333	T	1	S	4	0	M	64	N4		P		124790-XX6

Features

The computer has the following features:

- Intel Pentium III 500-MHz, Intel Pentium II 333-MHz, or Celeron 450- or 333-MHz processor, with 256-KB integrated L2 cache (Pentium III or II) or 128-KB integrated L2 cache (Celeron), depending on computer model
- ATI RAGE LT Pro, 4-MB SGRAM (synchronous graphics)
- Standard 64-MB high-performance synchronous DRAM (SDRAM), expandable to 512 MB
- Dual preinstall of Microsoft Windows 95 and Windows 98 or Windows NT Workstation 4.0 and Windows NT 2000 preinstalled*
- 11.3-inch XGA CTFT (1024 × 768) and 11.3-inch SVGA CTFT (800 × 600) displays with 16 million colors, depending on computer model
- Keyboard is 95 percent of full-size with TouchPad pointing device
- Full set of ports on system (serial, parallel, USB, Infrared, VGA)
- Mini PCI 56K V.90 modem, or optional Mini PCI V.90 plus 10/100 NIC combo card
- One Type II PC Card slot with support for both 32-bit CardBus and 16-bit PC Cards; zoomed video support
- External AC adapter with power cord
- Lithium ion (Li-ion) battery packs
 - Standard: 4 cell, 26 Watt hours (externally attaches to computer)
 - Optional: 6 cell, 40 Watt hours (externally attaches to computer)
 - Optional: MultiBay (for mobile expansion unit)
- High-capacity SMART hard drives, 12.0-, 6.4-, and 4.3-GB, with DriveLock security and Prefailure Warranty, depending on computer model
- Ultraportable form factor, 0.89 inch (2.3 cm) thin with weight starting at 3.1 lb. (1.4 kg), depending on configuration
- Standard external diskette drive (attaches to system through the parallel port or fits into the mobile expansion unit diskette drive bay)
- Optional Mobile Expansion Unit (MEU) conveniently adds:
 - Dedicated diskette drive bay
 - Flexible MultiBay that accommodates: 24X MAX CD-ROM drive or DVD-ROM drive, SuperDisk LS-120 drive, weight saver, second Li-Ion battery or secondary 6.4-GB hard drive
 - Additional ports: parallel, serial, audio in/out, VGA, USB, PS/2 (2), AC power in, CPU connector, docking connector
 - Stereo speakers providing Compaq PremierSound 16-bit stereo sound
 - Robust, common enterprise docking solution

* End user must make a one-time selection between Windows 95 and Windows 98. If end user desires rejected product(s) after selection is made, end user must acquire and pay for rejected product(s) separately.

Intelligent Manageability

Intelligent Manageability consists of preinstalled software tools for the computer and Compaq servers that assist in tracking, troubleshooting, protecting, and maintaining the computer. It provides the following functions:

- **Asset Management:** provides detailed configuration and diagnostic information.
- **Fault Management:** prevents, predicts, and alerts of impending hardware problems.
- **Security Management:** protects unauthorized access to data and components.
- **Configuration Management:** optimizes the computer by providing the latest drivers, utilities, and software, which are available on CD-ROM and the Compaq Web site at www.compaq.com/support/portables.

NOTE: For further help with Intelligent Manageability, select Start → Compaq Information Center → Intelligent Manageability

Accessing the Web Agent

The computer may have a preinstalled Web Agent that allows computer configuration information to be viewed using Web technology. To access this feature, select Start → Compaq Information Center → Insight Web Management.

If the computer does not have a preinstalled Web Agent, it can be downloaded from the Compaq Web site at www.compaq.com.

Asset Management

Asset Management enables component information to be retrieved when on the road or connected to the network.

Asset Management also enables the network administrator to remotely retrieve information from any Compaq computer connected to the network. The information can be used to assist in tracking and maintaining the computer and its components. It provides the following information:

- **Inventory information**—The network administrator can retrieve information about the computer over the network by using Compaq Insight Manager or any PC management tool provided by Compaq Solution Partners. Asset control information retrieved from the computer includes:
 - Manufacturer, model, and serial number of Compaq computers, monitors, hard drives, battery packs, memory boards, processor speeds, and operating systems
 - Asset tag
 - System board and ROM revision levels
 - BIOS settings
- **Diagnostic information**—Diagnostics for Windows includes information on hard drives, ports, video, sound, and other components. This application also allows the user to run multi-threaded tests on hardware components. If problems are found, recommendations are provided.

All of the above information can be viewed, printed, or saved.

Fault Management

Fault Management features minimize downtime and data loss by monitoring system performance and generating the following alerts:

- **Hard drive alert**—provides 72-hour advance warning of impending hard drive problems and can automatically start optional backup software.
- **System temperature alert**—reports overheating. As the system temperature rises, this feature first adjusts fan speed and other cooling components, then displays an alert, then shuts down the system.
- **Battery pack alert**—reports charging problems and battery pack failure.
- **Monitor alert**—diagnoses and displays external monitor operational problems.
- **Memory alert**—reports memory board configuration changes when a memory board is removed, added, or reconfigured. It also provides the previous and current configurations for comparison.

The alerts work with or without network connection. If the computer is not connected to the network, the network administrator cannot receive alerts from the computer.

Fault Management Alerts

Alerts can be enabled, disabled, and tested, and software can be set to back up information whenever a hard drive alert occurs.

- While the computer is connected to a network, alerts pop up on the computer display and are simultaneously reported to the network console.
- **System temperature alert**—reports overheating. As the system temperature rises, this feature first adjusts fan speed and other cooling components, then displays an alert, then shuts down the system.
NOTE: A battery charging problem alert is reported only on the computer display.
- When the computer is not connected to a network, the user will receive a local alert.
- To set alerts, select the Intelligent Manageability icon in the system tray.

Security Management

Security Management features customize system security.

- **Power-On and Setup Passwords**—prevent unauthorized access to information and computer configuration.
- **DriveLock**—prevents unauthorized access to hard drives.
- **Device disabling**—prevents unauthorized data transfer through modems, serial ports, parallel ports, and infrared ports on the computer and an optional docking station.
- **QuickLock/QuickBlank**—locks the keyboard and clears the screen.
- **Ownership Tag**—displays ownership information during system restart.

Configuration Management

Configuration Management optimizes software upgrade and customer support procedures. Compaq provides support software to optimize the performance of the computer. This support software is accessible through a monthly CD-ROM subscription. Support software can also be downloaded from the Compaq Web site at www.compaq.com/support/portables.

Managing Power

The computer comes with a collection of power management features that allow battery operating time to be extended and power to be conserved. Use power management to monitor most computer components such as the hard drive, processor, and display.

Accessing Power Management

- In Windows 95, select Start → Settings → Control Panel → Power to view or adjust settings in Power Properties.
- In Windows NT 4.0, select Compaq Power instead of Power
- In Windows 98, select Power Management.

Power Management Levels

To extend the life of batteries, use the Battery Conservation tab in Power Properties.

- If Windows 95 is running, select Start → Settings → Control Panel → Power to access Power Properties.
- In Windows NT 4.0, select Compaq Power instead of Power.
- In Windows 98, select Power Management.

The level of battery conservation or the selection of preset power management levels can be customized.

1.2 Computer External Components

The external components on the top of the computer are shown in Figure 1-2 and described in Table 1-2.

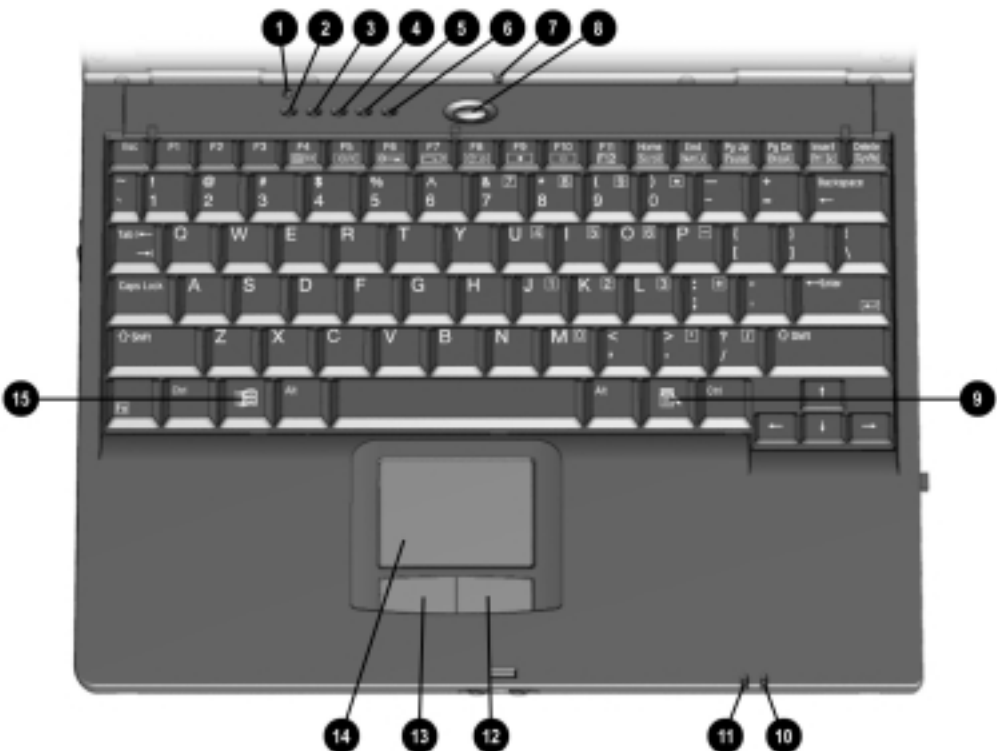

Figure 1-2. Top Components

**Table 1-3
Top Components**

Item	Component	Function
1	Display switch	Turns off the computer display if the computer is closed while on.
2	Scroll lock light	On: Scroll lock is on.
3	Caps lock light	On: Caps lock is on.
4	Num lock light	On: Num lock is on and the embedded numeric keypad is enabled.
5	Hard drive light	On: The primary hard drive is being accessed.
6	Diskette drive light	On: The external diskette drive is being accessed.
7	Internal microphone	Supports audio input when the display is open or closed.
8	Suspend button	Initiates and exits Suspend.* When pressed with the Fn key, initiates Hibernation.
9	Windows application key	Displays shortcut menu for item beneath mouse cursor.
10	Battery light	On: The battery pack is charging. Blinking: The battery pack, that is the only available power source, has reached a low-battery condition.
11	Power/suspend light	On: Power is turned on. Off: Power is turned off. Blinking: Computer is in Suspend.* NOTE: The power/suspend light also blinks if a battery pack that is the only source of power available to the computer reaches a critical low-battery condition while Hibernation is disabled.
12	Right mouse button	Functions like the right click button of an external mouse.
13	Left mouse button	Functions like the left-click button of an external mouse. Used with the TouchPad to drag and highlight.
14	TouchPad	Moves the mouse cursor, selects, and activates.
15	Microsoft logo key	Displays Windows Start menu.

*In Windows 98 the term *Standby* replaces the term *Suspend*.

In Windows 98 the term *sleep button* replaces the term *suspend button*.

The external components on the left side of the computer are shown in Figure 1-3 and are described in Table 1-3.

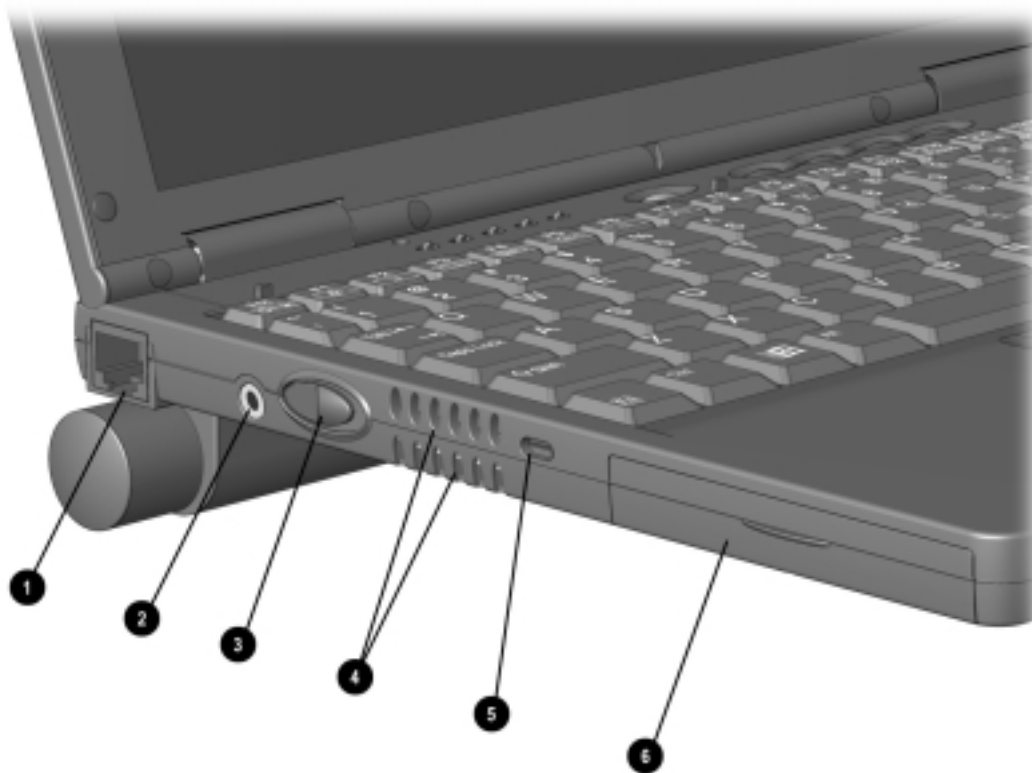

Figure 1-3. Left Side Components

Table 1-4
Left Side Components

Item	Component	Function
1	RJ-45 jack*	Connects the network cable. NOTE: A network cable is included with network models. Internal modem/NIC models only
2	Power connector	Connects the AC power adapter.
3	Power button	Turns the computer on or off or exits Suspend.
4	Vents	Cools internal components.
5	Security cable slot	Attaches an optional security cable to the computer.
6	Hard drive bay	Holds primary hard drive.



WARNING: To reduce the risk of electric shock, fire, or damage to the equipment, do not plug a telephone cable into the Ethernet RJ-45 jack.

The external components on the right side of the computer are shown in Figure 1-4 and are described in Table 1-4.

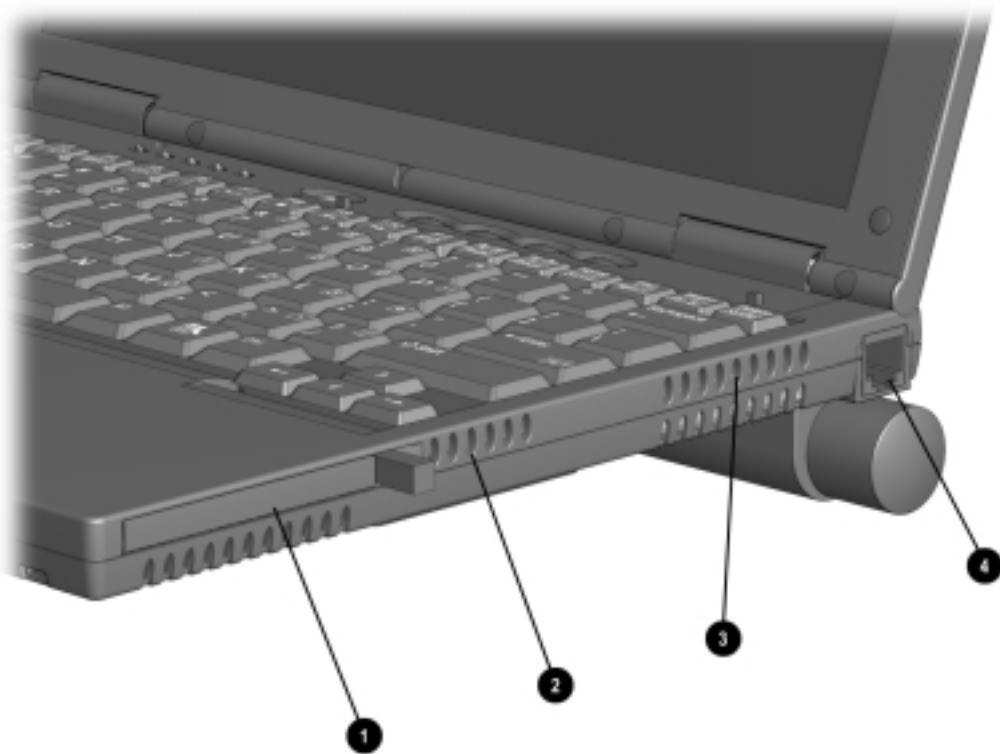

Figure 1-4. Right Side Components

**Table 1-5
Right Side Components**

Item	Component	Function
1	PC Card slot	Supports 32-bit (CardBus) and 16-bit PC Cards.
2	Air intake vents	Cool internal components.
3	Air exhaust vents	Cool internal components.
4	RJ-11 jack (internal modem models only)	Connects the modem cable to an internal modem. NOTE: A modem cable is included with internal modem models.

The external components of the front of the computer are shown in Figure 1-5 and described in Table 1-5.

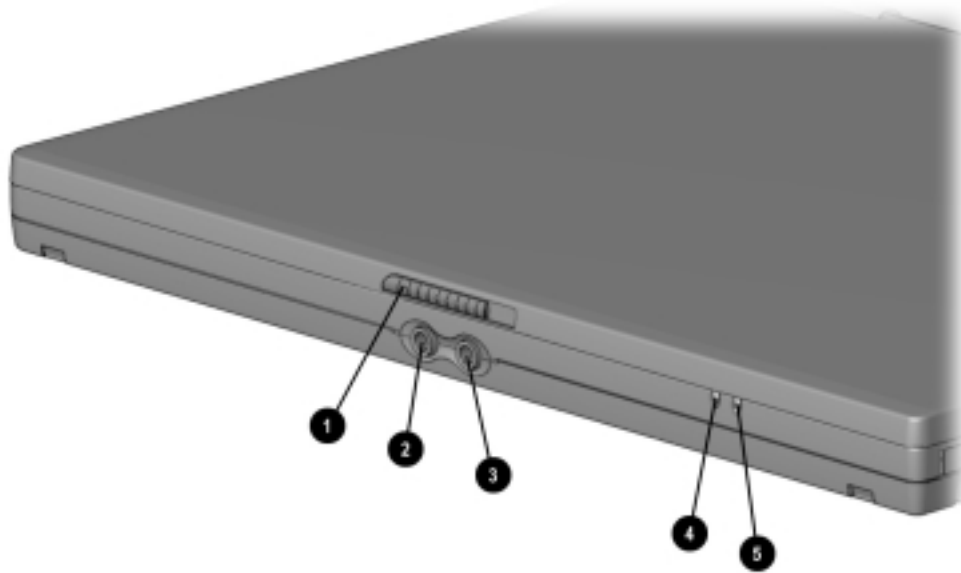

Figure 1-5. Front Components

Table 1-6
Front Components

Component	Function
1 Display release latch	Opens the computer.
2 Stereo speaker/headphone jack	Connects stereo speakers, headphones, or headset audio.
3 Microphone jack	Connects a single sound channel microphone.
4 Power/suspend light	On: Power is turned on. Off: Power is turned off. Blinking: Computer is in Suspend. NOTE: The power/suspend light also blinks if a battery pack that is the only source of power available to the computer reaches a critical low-battery condition while Hibernation is disabled.
5 Battery light	On: A battery pack is charging. Blinking: A battery pack that is the only available power source has reached a low-battery condition.

The external components on the rear of the computer are shown in Figure 1-6 and described in Table 1-6.

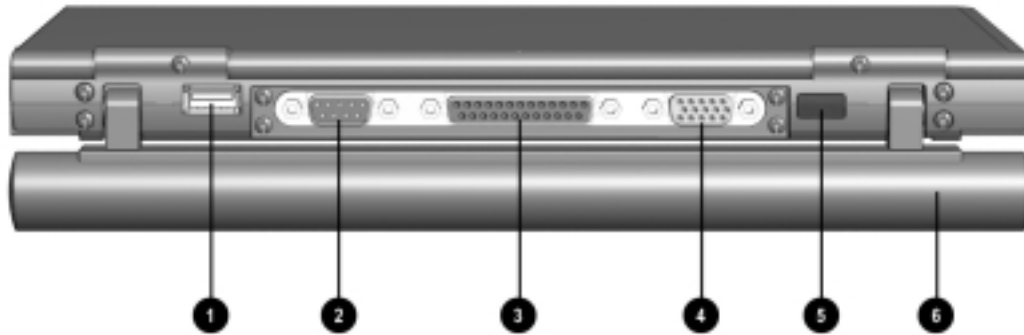

Figure 1-6. Rear Components

**Table 1-7
Rear Components**

Item	Component	Function
1	USB connector	Connects USB devices
2	Serial connector	Connects a serial device
3	Parallel connector	Connects a parallel device
4	External monitor connector	Connects an external monitor, overhead projector, or TV adapter.
5	Infrared port	Links to another IrDA-compliant device for wireless communication.
6	Battery pack	Provides power to the computer.

The external components on the bottom of the computer are shown in Figure 1-7 and are described in Table 1-7

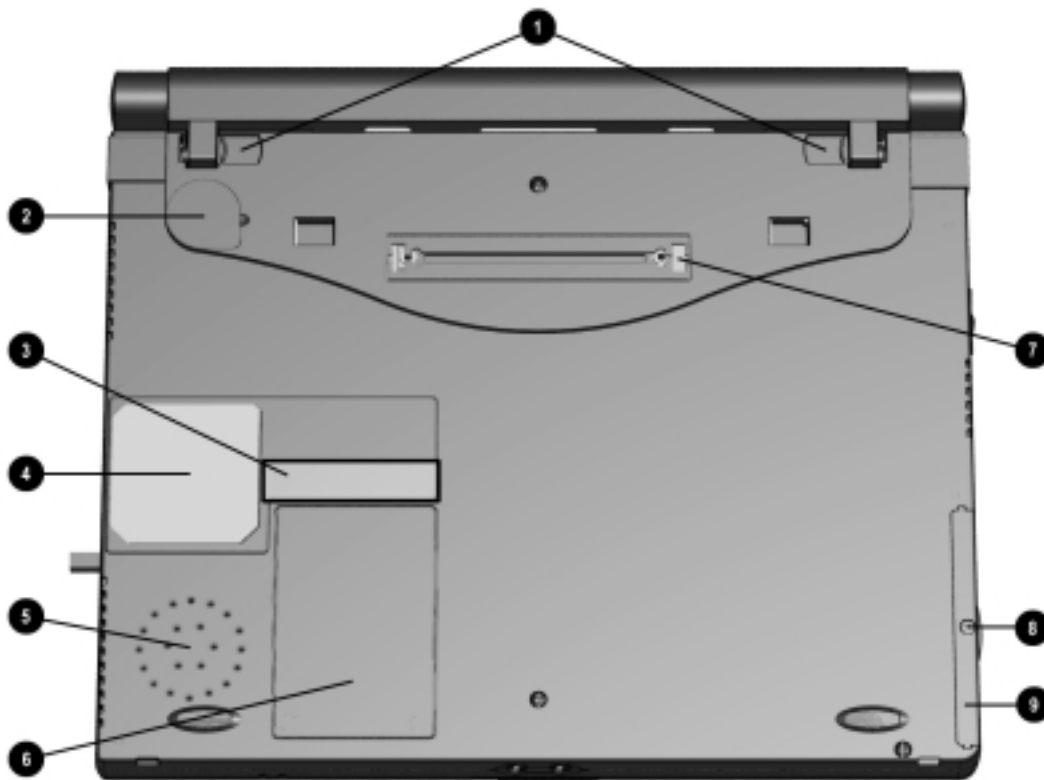

Figure 1-7. Bottom Components

**Table 1-8
Bottom Components**

Item	Component	Function
1	Battery latches	Release the primary battery pack.
2	Real-time clock battery	Provides battery power to automatically display the date and time.
3	Serial number	Numerical identification for the computer.
4	Fan	Cools the computer.
5	Speaker	Produces sound.
6	Modem compartment	Provides access to the internal modem (modem models only).
7	docking connector	Connects the computer to a docking base.
8	Hard drive security screw	Secures hard drive in computer hard drive bay.
9	Hard drive bezel	Releases a hard drive from the hard drive bay.

1.3 Design Overview

This section presents a design overview of key parts and features of the computer. Refer to Chapter 3 for the illustrated parts catalog and Chapter 5 for removal and replacement procedures.

System Board

The system board provides the following device connections:

- Memory expansion board
- Hard drive
- Display
- Keyboard/Touchpad pointing device
- Audio
- Pentium II/Celeron processor
- Fan
- PC Cards
- Modem

The computer is equipped with an Intel Pentium III 500-MHz, Intel Pentium II 333-MHz, or Celeron 450- or 333-MHz processor. For ventilation, an electrical fan is installed. The fan is controlled by a temperature sensor. The fan is designed to turn on automatically when high temperature conditions exist. These conditions are affected by high external temperatures, system power consumption, power management/battery conservation configurations, battery fast charging, and software applications. Exhaust air is displaced through the ventilation grill located on the right side of the computer.



CAUTION: To properly ventilate the computer, allow at least a 3-inch (7.6 cm) clearance on the left and right sides of the computer.

chapter 2

TROUBLESHOOTING

Follow these basic steps when beginning the troubleshooting process:

1. Complete the preliminary steps listed in Section 2.1.
2. Run the Power-On Self-Test (POST) as described in Section 2.3.
3. Run Computer Setup as described in Section 2.5.
4. If you are unable to run POST or if the problem persists after running POST, perform the recommended actions described in the diagnostic tables in Section 2.5.

Follow these guidelines when troubleshooting:

- Complete the recommended actions in the order in which they are given.
- Repeat POST after each recommended action until the problem is resolved and the error message does not return.
- When the problem is resolved, stop performing the troubleshooting steps and do not complete the remaining recommended actions.
- Refer to Chapter 5 for recommended removal and replacement procedures.
- If the problem is intermittent, check the computer several times to verify that the problem is solved.

The following table describes the troubleshooting actions:

If You Want To:	Then Run:
Check for POST error messages	POST
Perform any of the following: <ul style="list-style-type: none">■ Check the system configuration■ Set the system power management parameters■ Return the system to its original configuration■ Check system configuration of installed devices	Computer Setup

2.1 Preliminary Steps

IMPORTANT: Use AC power when running POST or Computer Setup. A low battery condition could initiate Hibernation and interrupt the test.

Before running POST, complete the following steps:

1. Obtain established passwords. If you must clear the passwords, go to Section 2.2.
2. Ensure that the battery pack is installed and the power cord is connected to the computer and plugged into an AC power source.
3. Turn on the computer.
4. If a power-on password has been established, type the password and press **Enter**.
5. Run Computer Setup (Section 2.5). If a Setup password has been established, type the password and press **Enter**.
6. Turn off the computer and all external devices.
7. Disconnect external devices that you do not want to test. If you want to use the printer to log error messages, leave it connected to the computer.

NOTE: If a problem only occurs when an external device is connected to the computer, the problem could be with the external device or its cable. Isolate the problem by running POST with and without the external device connected.

8. Use Compaq Utilities and loopback plugs in the serial and parallel connectors if you plan to test these ports.

Follow these steps to run Compaq Utilities:

- a. If you are running Compaq Utilities from the hard drive, turn on or restart the computer. Press **F10** when the cursor appears in the upper-right corner of the screen. If you do not press **F10** in time, restart the computer and try again.

If you are running Compaq Utilities from diskette, insert the Compaq Utilities diskette in drive A. Turn on or restart the computer.

- b. Press **Enter** to accept **OK**.
- c. Select Prompted Diagnostics.
- d. After “Identifying System Hardware” completes, select Interactive Testing and follow the instructions on the screen.

2.2 Clearing Passwords

1. Turn off the computer.
2. Disconnect the computer (Section 5.4).
3. Remove the battery pack (Section 5.6).
4. Disconnect and remove the Real Time Clock (RTC) battery (Section 5.10).
5. Wait five minutes.
6. Reconnect the RTC battery.
7. Reconnect the AC Adapter. Do **not** reinstall the battery pack yet.
8. Turn on the computer.

NOTE: Remember to set the date and time the next time the computer is turned on.

2.3 Power-On Self-Test (POST)

The Power-On Self-Test (POST) is a series of tests that run every time the computer is turned on. POST verifies that the system is configured and functioning properly.

To run POST, complete the following steps:

1. Complete the preliminary steps (Section 2.1).
2. Turn on the computer.

If POST does not detect any errors, the computer beeps once or twice to indicate that POST has run successfully. The computer boots from the hard drive or from a bootable diskette if one is installed in the diskette drive.

2.4 POST Error Messages

If the system is not functioning well enough to run POST, or if the display is not functioning well enough to show POST error messages, refer to the Troubleshooting tables in Section 2.6.

If POST detects an error, one of the following events occurs:

- A message with the prefix "WARNING" appears, informing you where the error occurred. The system pauses until you press **F1** to continue.
- A message with the prefix "FATAL" appears, informing you where the error occurred. After the message, the system emits a series of beeps, then stops.
- The system emits a series of beeps, then stops.

Warning messages indicate that a potential problem, such as a system configuration error, exists. When **F1** is pressed, the system should resume. You should be able to correct problems that produce WARNING messages.

If you receive one of the error messages listed below, follow the recommended action.

Table 2-1
Warning Messages

Message	Description	Recommended Action
CMOS checksum invalid, run SCU	CMOS RAM information has been corrupted.	Run Computer Setup to reinitialize CMOS-RAM.
CMOS failure, run SCU	CMOS RAM has lost power.	Run Computer Setup to reinitialize CMOS-RAM.
Diskette controller error	The diskette drive controller failed to respond to the recalibrate command.	If there is no diskette drive in the system, run Computer Setup to properly configure the CMOS-RAM to show no diskette drive present. If the problem persists, or if a diskette drive is present, complete these steps until the problems is solved: <ol style="list-style-type: none">1. Check diskette drive connections.2. Replace diskette drive.3. Replace system board.
Diskette track 0 failed	The diskette drive cannot read track 0 of the diskette in the drive.	Try another diskette. If the problem persists, you may need to replace the diskette drive.

Continued

Table 2-1 *Continued*

Message	Description	Recommended Action
Hard disk controller error	The hard drive controller failed to respond to the reset command.	Check the drive parameters. Turn off the system and check all related connections.
Keyboard controller failure	The keyboard failed the self-test command.	Replace the system board.
Keyboard failure	The keyboard failed to respond to the RESET ID command.	Replace the keyboard. If the problem persists, replace the system board.
No interrupts from Timer 0	The periodic timer interrupt is not occurring.	Replace the system board.
ROM at xxxx (LENGTH yyyy) with nonzero checksum (zz)	An illegal adapter ROM was located at the specified address.	Check the external adapter (such as a video card) to determine if it is causing the conflict.
Time/Date corrupt - run SCU	The time and date stored in the real time clock have been corrupted, possibly by a power loss.	1. Run Computer Setup. 2. If problems persists, replace system board.
Hard disk xx failure (or error)	A failure or an error occurred when trying to access the hard drive.	1. Run ScanDisk. 2. Check disk in DOS and Windows 95.

Fatal errors emit a beep and may display a FATAL message. Fatal errors indicate severe problems, such as a hardware failure. Fatal errors do not allow the system to resume. Some of the Fatal error beep codes are listed at the end of this section.

Table 2-2
Fatal Error Messages

Message	Description	Beep code
CMOS RAM test failed	A walking bit test of CMOS RAM location 0E (Hex) - 3F (Hex) failed.	3
DMA controller faulty	A sequential read/write of the transfer count and transfer address registers within the primary and secondary DMA controllers failed.	4
Faulty DMA page registers	A walking bit read/write of the 16 DMA controller page registers starting at location 80 Hex failed.	0
Faulty refresh circuits	A continuous read/write test of port 61h found that bit 4 (Refresh Detect) failed to toggle within an allotted amount of time.	1
Interrupt controller failed	A sequential read/write of various Interrupt Controller registers failed.	5
ROM checksum incorrect	A checksum of the ROM BIOS does not match the byte value at F000:FFFF.	2
RAM error at location xxxx	RAM error occurred during memory test.	None

*Beep codes are defined in Table 2-3.

**Table 2-3
Fatal Error Beep Codes**

Beep Code	Beep Sequence	Description	Recommended Action
0	S-S-S-P-S-S-L-P	The DMA page registers are faulty.	Replace system board.
1	S-S-S-P-S-L-S-P	The refresh circuitry is faulty.	
2	S-S-S-P-S-L-L-P	The ROM checksum is incorrect.	
3	S-S-S-P-L-S-S-P	The CMOS RAM test failed.	
4	S-S-S-P-L-S-L-P	The DMA controller is faulty.	
5	S-S-S-P-L-L-S-P	The interrupt controller failed.	
6	S-S-S-P-L-L-L-P	The keyboard controller failed.	
7	S-S-L-P-S-S-S-P	Graphics adapter is faulty.	
8	S-S-L-P-S-S-L-P	Internal RAM is faulty.	Replace memory board or system board if memory on system board is faulty.

NOTE: S = Short, L = Long, P = Pause

2.5 Compaq Utilities

Compaq Utilities contain several functions that

- Determine if various computer devices are recognized by the system and are operating properly.
- Provide information about the system once it is configured.

Compaq Utilities include the following programs:

- Computer Setup
- Compaq Diagnostics

To access Compaq Utilities:

1. Turn on or restart the computer by clicking Start→Shut Down→Restart the computer.
2. Press **F10** when the blinking cursor appears in the upper-right corner of the display.
3. Select a menu option.

Selecting Computer Setup or Compaq Diagnostics for Windows

The computer features two system management utilities:

- **Computer Setup** is a system information and configuration utility that can be used even when your operating system is not working or will not load. It includes custom settings that are not available in Windows.

To configure a device in Windows NT 4.0, you must use Computer Setup.

- **Compaq Diagnostics for Windows** is a system information and diagnostic utility that is used within the Windows operating system. Use Compaq Diagnostics for Windows to test system components and to display system information whenever possible.

To configure a device in Windows 95 or 98 use the operating system itself. Windows 95 and 98 can be used to add and remove programs, and provide Wizards to ensure proper device drivers are installed. Diagnostics for Windows is NOT a configuration tool and might only test devices that are properly configured by the operating system.

NOTE: It is not necessary to configure a device connected to a USB connector on the computer or an optional docking base.

Using Computer Setup

All information and settings in Computer Setup are accessed from the File, Security, or Advanced menus.

NOTE: Your settings in Computer Setup are not affected by updating the system ROM.

To view information or change a setting in Computer Setup:

1. Turn on or restart the computer. When the blinking cursor appears in the upper-right corner of the screen, press **F10**.
 - To change the language, press **F2**.
 - To view navigation information, press **F1**.
 - To return to the Computer Setup menu from anywhere in Computer Setup, press **Esc**.
2. Select the File, Security, or Advanced menu.
3. To close Computer Setup and restart the computer
 - Select File→Ignore Changes and Exit, then press **Enter**.
 - or
 - Select File→Save Changes and Exit, then press **Enter**.
4. To confirm your choice, press **F10**.

File Menu

Begin here	To do this
System information	<ul style="list-style-type: none">■ View identification information about the computer, docking base, and battery packs.■ View specification information about the processor, memory and cache size, and ROM date and family.
Save to floppy	Save system configuration to a diskette.
Restore from floppy	Restore system configuration from a diskette. (The diskette contains your personal configuration, so you should restore from the diskette before using the System Recovery CD-ROM.)
Restore defaults	Replace configuration settings in Computer Setup with factory default settings. (Identification information is retained.)
Ignore changes and exit	Cancel changes entered during the current Computer Setup session, then exit and restart the computer.
Save changes and exit	Save changes, then exit and restart the computer.

Security Menu

Begin here	To do this
Setup password	Enter, change, or delete a setup password.
Power-On password	Enter, change, or delete a power-on password.
Password options	Enable/disable: <ul style="list-style-type: none">■ QuickLock/QuickBlank■ Lock keyboard and touchpad at startup. (These features can be enabled only when a power-on password is set.)
DriveLock passwords	Enter, change, or delete a DriveLock password.
Device security	Enable/disable <ul style="list-style-type: none">■ Ports or diskette drives.■ Diskette write.■ CD-ROM or diskette startup. NOTE: Settings for a DVD-ROM can be entered in the CD-ROM field.
System IDs	Enter identification numbers for the computer, a docking base, and battery packs.

Advanced Menu

Begin here	To do this
Language (or press F2)	Change the Computer Setup language.
Boot Options	Enable/disable <ul style="list-style-type: none">■ QuickBoot, which starts the computer more quickly by eliminating some startup tests. (If you suspect a memory failure and want to test memory automatically during startup, you may want to disable QuickBoot.) MultiBoot, which enables you to set a startup sequence that can include any drives in the system.
Device Options	<ul style="list-style-type: none">■ Enable/disable the embedded numeric keypad at startup.■ Enable/disable multiple standard pointing devices at startup. When this feature is disabled, only one pointing device is activated at startup.■ Enable/disable USB legacy support for one USB mouse and one USB keyboard. (When USB legacy support is enabled, the keyboard and mouse work without a loaded USB driver.)■ Set an optional external monitor or overhead projector connected to a video card in a docking base as the primary device. (When the computer display is set as secondary, the computer must be shut down before undocking.)■ Set video-out mode to NTSC (default), NTSC-J, PAL, or PAL-M. Change the parallel port mode to or from EPP, standard, bidirectional, or ECP.

Using Compaq Diagnostics for Windows

1. Access Compaq Diagnostics for Windows by selecting Start → Settings → Control Panel → Compaq Diagnostics.
2. To select a category, choose one of two methods:
 - Select the Categories menu, then select a category from the drop-down list.
 - Select a category icon on the toolbar.
3. To run diagnostic tests
 - a) Select the Test tab.
 - b) In the scroll box, select the category or device you want to test.
 - c) Select the Quick, Complete, or Custom test type.
 - d) Select the Interactive or Unattended test mode.
 - e) Select the Begin Testing button.
 - f) View test information by selecting a report from the Status, Log, or Error tab.
4. To print the information or save it to a drive, select the File menu, then select Print or Save As.
5. To exit, select the File menu → Exit.

Factory Default Settings

NOTE: Default settings that do not apply to the computer will appear in gray.

Enable POST Memory Test	Checked (enabled)
Keyboard Num Lock	Unchecked (Off)
Hard drive boot sequence	
1	Hard drive in the computer MultiBay
2	Hard drive in the computer hard drive bay
3	Hard drive in the expansion base or convenience base half-height/MultiBay
4	Hard drive in the expansion base or convenience base MultiBay
Boot display	Auto
Language	Language of country

**Table 2-5
Ports**

Serial port	3F8, IRQ4
Infrared port	2F8, IRQ9
Parallel port	378, IRQ7
Ethernet port	300, IRQ11

**Table 2-6
Power**

Low Battery Warning Beep	Checked (enabled)
External Energy Saving Monitor Connected	Unchecked (not connected)
Power Management	
Enabled	While operating on battery power
Conservation Level	High
Level Definition	
High	Suspend Time: 3 minutes Hibernation Timeout: Immediate Drive Timeout: 1 minute Screen Timeout: 1 minute
Medium	Suspend Time: 5 minutes Hibernation Timeout: 1 hour Drive Timeout: 2 minutes Screen Timeout: 3 minutes
Custom	Suspend Time: disabled Hibernation Timeout: low battery Drive Timeout: always on Screen Timeout: always on

**Table 2-7
Security**

Enable QuickLock/QuickBlank	Unchecked (Disabled)
Enable Power-On Password	Unchecked (Disabled)
Disable Serial/Infrared Ports	Unchecked (Enabled)
Disable Parallel Port	Unchecked (Enabled)
Disable PC Card Slots	Unchecked (Enabled)
Setup Password	Password blank
Power-On Password	Password blank
Diskette Drives	
Disable Diskette Drives	Unchecked (Enabled)
Disable Diskette Boot	Unchecked (Enabled)

2.6 Troubleshooting Without Diagnostics

This section provides information about how to identify and correct some common hardware, memory, and software problems. It also explains several types of messages that may be displayed on the screen.

Since symptoms can appear to be similar, carefully match the symptoms of the computer malfunction against the problem description in the Troubleshooting tables to avoid a misdiagnosis.

Before Replacing Parts

When troubleshooting a problem, check the following items for possible solutions before replacing parts:

- Verify that cables are connected properly to the suspected defective parts.
- Verify that all required device drivers are installed.
- Verify that all printer drivers have been installed for each application.

Obtaining Update Information with Info Messenger

Compaq Info Messenger allows you to set a customized search of the Compaq Web site. By registering for this utility, you can stay up to date with software and hardware information specific to your system.

- To access Compaq Info Messenger, go to www.compaq.com and select Info Messenger.
- To register, follow the instructions on the Info Messenger page. When your registration is complete, you can
 - Implement your customized search whenever you prefer from the Info Messenger page.
 - Set Info Messenger to send you the information by email as it becomes available.

Info Messenger will also inform you if there are updates to the system ROM for your computer.

Checklist for Solving Problems

If you encounter a minor problem with the computer or software applications, go through the following checklist for possible solutions:

- Is the computer connected to an external power source, or does it have a fully charged battery pack installed?
- Are all cables connected properly and securely?
- Did the diskette drive contain a nonbootable diskette when you turned on the computer?
- Are all the needed device drivers installed?
- Are printer drivers installed for each application?

If the problem appears related to a software application, check the documentation provided with the software.

Table 2-8
Solving Audio Problems

Problem	Possible Cause	Solution
Computer does not beep after the Power-On Self-Test (POST).	System beeps have been turned down.	Use the Fn+F5 hotkeys to turn up the system volume.
Internal speaker does not produce sound when an external audio source is connected to the stereo line-jack.	Volume may be turned off or set too low.	<ul style="list-style-type: none"> ■ Adjust the overall volume by pressing the Fn+F5 hotkeys. ■ Adjust the sliding mixer controls by double-clicking the speaker icon on the Windows taskbar.
	Line input may not be connected properly.	Check line input connection.
	Headphones or speakers are connected to the stereo speaker/headphone jack, which disables the internal speakers.	Disconnect the head-phones or speakers to enable the internal speakers.
	Volume may be muted	Uncheck the mute box in the volume properties.

Continued

Table 2-8 *Continued*

Problem	Possible Cause	Solution
External microphone does not work.	You are using the wrong type of microphone or microphone plug for the computer.	Check to see if you are using a monophonic electret condenser micro-phone with a 3.5-mm plug.
	The microphone may not be connected properly.	Ensure that the micro-phone plug is properly connected to the mono microphone jack.
	Sound source not selected.	Ensure that microphone is selected as the recording source in Control Panel → Multimedia and that the recording level is adjusted.
	Audio settings are not set correctly.	Check the game program's audio settings.
	Volume control on the computer is turned down.	Adjust the computer volume with the Fn+F5 hotkeys.
No sound from headphones	Volume or mixing controls set incorrectly.	<ul style="list-style-type: none"> ■ Adjust the overall volume with the Fn+F5 hotkeys. ■ Use the mixing features available by double-clicking the speaker icon on the Windows taskbar.
	Sound source not selected.	Verify that the sound source is selected in Control Panel → Multimedia.
	The headphones are connected to the wrong jack.	Check the connection.
Volume too low or too loud	Volume or mixing controls set incorrectly.	<ul style="list-style-type: none"> ■ Adjust the overall volume with the Fn+F5 hotkeys. ■ Replace the battery pack with another fully charged battery pack. ■ Check the mixing features available by double-clicking the speaker icon on the Windows taskbar.

Table 2-9
Solving Battery/Battery Gauge Problems

Problem	Possible Cause	Solution
Computer is beeping and battery power light is blinking	Battery pack charge is low.	<ul style="list-style-type: none"> ■ Charge the battery pack by connecting to an external power source. ■ Replace the battery pack with another fully charged battery. ■ Initiate Hibernation or turn the computer off until AC power or a fully charged battery is available.
Computer battery charge light blinks to indicate low battery condition, but computer does not beep.	Volume turned down too low.	Turn up the volume using the Fn+F5 hotkeys.

Continued

Table 2-9 *Continued*

Problem	Possible Cause	Solution
Battery pack will not charge.	Battery pack was exposed to temperature extremes.	Allow time for the battery pack to return to room temperature.
	Battery pack is already charged.	No action required.
	Battery pack has exceeded its useful life cycle.	Use a different battery pack.
Computer shut down and memory was lost when replacing the battery pack.	Hibernation was not initiated before removing the battery pack.	Work is lost.
Battery charge does not last very long.	Battery is exposed to higher temperatures.	Put the computer in a cooler place and recharge the battery pack.
	Battery is exposed to extremely cold temperatures.	Put the computer in a warmer place and recharge the battery pack. NOTE: The recommended operating temperature range for the battery is from 10°C to 40°C (50°F to 104°F). The recommended storage temperature range for the battery is from 0°C to 30°C (32°F to 86°F).
	Battery conservation is disabled or set to drain.	Reset the battery conservation level.
	An external device is draining the battery.	Turn off or remove any external device or PC Cards when not in use.
	Battery gauge may be inaccurate and require recalibration.	Recalibrate the gauge.
Date and time must be set every time computer is turned on.	The Real Time Clock battery has reached the end of its useful life.	<ul style="list-style-type: none"> ■ Restore power, then turn on the computer with the power switch ■ Replace the Real Time Clock battery.
Battery gauge seems inaccurate.	The battery pack may need calibration.	Recalibrate the battery.
	The battery pack has reached the end of its useful life.	Replace the battery pack.
Battery pack is warm after charging.	Warming occurs during charging.	No action required.

Table 2-10
Solving Compact Disc and DVD-ROM Problems

Problem	Possible Cause	Solution
Drive cannot read a disc	Disc is not properly seated in the drive.	Open the loading tray, insert the disc, then close the tray.
	Disc is loaded in the loading tray upside down.	Open the loading tray, turn over the disc (label facing up), then close the tray.
	Disc has a scratch on its surface.	Insert a different disc.
CD-ROM drive or DVD-ROM drive is not detected by the computer.	Drive is not connected properly.	If you are running a version of Windows that was pre-installed by Compaq, remove the drive from the MultiBay and reinsert it. If you are running a version of Windows that was not pre-installed by Compaq, turn off the computer. Then remove the drive from the MultiBay and reinsert it.

Table 2-11
Solving Diskette Drive/SuperDisk LS-120 Drive Problems

Problem	Possible Cause	Solution
Drive cannot write to a diskette.	Diskette is not formatted.	Format the diskette: If you are using Windows 95 or Windows 98: 1. From the Windows desktop, select My Computer. 2. Select 3.5-in. Floppy (A). 3. Select File, then Format. 4. Fill in the appropriate information, then select Start. If you are using Windows NT 4.0, format the diskette by entering format a: at the system prompt.
	Diskette is write-protected.	Use another diskette that is not write-protected or disable the write-protect feature.
	Writing to the wrong drive.	Check the drive letter in your path statement.
	Not enough space is left on the diskette.	Save the information to another diskette.
	Drive is disabled.	Enable the proper drive through Device Manager.
	Disable diskette write ability is turned on.	Run Computer Setup. Select the Storage icon. Make sure Disable diskette write ability is not checked.

Continued

Table 2-11 *Continued*

Problem	Possible Cause	Solution
System cannot start up from diskette or SuperDisk LS-120 drive.	A bootable diskette is not in the drive.	Verify that a diskette with the necessary system files is in the drive.
	Diskette bootability is disabled in Computer Setup.	Enable diskette bootability in Computer Setup, Security menu.

Table 2-12
Solving Hard Drive Problems

Problem	Possible Cause	Solution
Accessing information on the hard drive is much slower than usual.	Hard drive entered low power state due to timeout and is now exiting from it.	Wait for the system to restore the previously saved data to its state prior to initiating a low power state.
	Hard drive is fragmented/not optimized or has errors.	Run ScanDisk and Disk Defragmenter.
Hard drive does not work.	Hard drive is not seated properly.	Turn off and unplug the computer, remove the hard drive, and reinsert the hard drive.
Errors occur after starting from an additional hard drive.	Additional hard drive has not been specially prepared with necessary software.	Boot from the original hard drive or a specially prepared hard drive.
System does not recognize a hard drive.	The drive is not seated properly.	Remove, then reinsert the drive.
	The drive is damaged.	Run ScanDisk on the drive.
	The drive was inserted while system was on or in Suspend or Hibernation.	Shut down the computer before inserting removing a hard drive.
DriveLock settings cannot be accessed in Computer Setup.	The DriveLock settings are accessible only when you enter Computer Setup by turning on (not restarting) the computer.	Completely turn off the computer. Turn the computer back on, then run Computer Setup by pressing F10 when the blinking cursor light appears upper-right on the screen.

**Table 2-13
Solving Infrared Problems**

Problem	Possible Cause	Solution
Cannot communicate with another computer.	The appropriate software is not running on both computers.	Install the appropriate software on the second device, start the second device, and start the program on both computers.
	The other computer does not have an IrDA-compliant infrared port. Your Compaq computer uses the IrDA communications protocol.	Communication between infrared devices must use the same communications protocol. Check the manufacturer's instructions for connecting with infrared devices or try connecting with a device you know to be IrDA-compliant.
	The pathway between the infrared ports is obstructed, one port is more than 30 degrees (plus or minus 15 degrees off the center line) from the other, or the ports are more than one meter apart.	Remove the obstruction, align the infrared ports to within 30 degrees, and position computers within 1.5 feet (about 0.5 meter) of each other.
	There is an interrupt request (IRQ) conflict.	Check for IRQ conflicts in the Device Manager. If two devices have the same IRQ address, reassign one of the devices.
	There is a baud rate conflict.	Select the same baud rate for both computers.
	There is a conflict with the # bits.	Select the same # bits setting for both computers.
	There is a stop byte conflict.	Select the same stop byte for both computers.
	There is a parity conflict.	Select the same parity setting for both computers.
Cannot transmit data.	Direct sunlight, fluorescent light, or flashing incandescent light is close to the infrared connections.	Remove the interfering light source(s).
	There is interference from other wireless devices.	Keep remote control units such as wireless headphones and other audio devices away from the infrared connections.
	There is a physical obstruction in the way.	Do not place objects that will interfere with a line-of-sight data transmission between the two units.
	One of the units was moved during data transmission.	Do not move either unit during data transmission.
	The orientation of the units is wrong.	Adjust the devices so that they point directly at each other.
	The distance between the units is too great.	Verify that devices are not more than 1.5 feet (0.5 meter) apart.

Continued

Table 2-13 *Continued*

Problem	Possible Cause	Solution
Infrared port doesn't work.	Direct sunlight, fluorescent light, or flashing incandescent light is close to the infrared connections.	Remove the interfering light source(s).
	There is interference from other wireless devices.	Keep remote control units such as wireless headphones and other audio devices away from the infrared connections.
	IR has been disabled.	Run IR configuration utility in Control Panel.

Table 2-14
Solving Keyboard Problems

Problem	Possible Cause	Solution
Screen is blank and keyboard is working.	A screen timeout has been initiated..	Press any key to refresh the screen.
	QuickLock/QuickBlank has been initiated	To enable the keyboard and return your information to the screen, enter your power-on password.
	LCD has been disabled.	Press Fn+F4 to cycle from external monitor to internal LCD.
Embedded numeric keypad on computer keyboard is disabled.	Num Lock function is not turned on	Press Fn+Num Lk to enable the Num Lock function and embedded numeric keypad.

Table 2-15
Solving Modem Problems

Problem	Possible Cause	Solution
Modem loses connection.	The cable connection from the phone line to the modem is loose.	Check to make sure the telephone cable is properly connected.
	Call Waiting has not been disabled.	Disable Call Waiting: 1. Select Start → Setting → Control Panel → select Modems. 2. From the General tab of the Modems Properties page, select Dialing Properties. From the My Locations tab of the Dialing Properties page, check the box labeled This location has call waiting. Select *70, 70#, or 1170 from the drop-down list to disable call waiting.
	There is noise or excessive traffic on the phone line.	Try connecting at a later time.
Modem not responding	Modem is not set up correctly in system BIOS.	Check the computer BIOS setup. If it requires specific settings for modems, be sure that they have been enabled.

Continued

Table 2-15 *Continued*

Problem	Possible Cause	Solution
Modem does not dial correctly.	Telephone number is not entered correctly in the modem's dialing software.	<ul style="list-style-type: none"> ■ Make sure the telephone number you dialed is correct if you are using the dialing directory or the terminal mode. ■ Dial 1 if using dialing long distance. ■ The other line could be busy or not answering. ■ Make sure call waiting is disabled. ■ The modem may not recognize an international dial tone. Try the ATX3DT command and the telephone number.
Characters are garbled/transfer rates are slow.	There is noise in the telephone line.	<ul style="list-style-type: none"> ■ Check your telephone and modem cable connections. If they are a little loose, they can cause noise on the line. ■ Check with your local telephone company for a phone line filter.
Phone line noise causing a disconnection.	Hang-up Delay S Register (S10) set too low.	<p>Change S10 default to 150.</p> <p>To set S10=150:</p> <ol style="list-style-type: none"> 1. Select Start → Programs → Accessories → HyperTerminal, then go to Command Mode. 2. Type ATS10=150 and press Enter. <p>This command causes the modem to take longer to disconnect even if there is no noise on the line.</p>
No dial tone	Phone service is not connected to the telephone wall jack.	<p>Verify that service from the local phone company by following these steps:</p> <ol style="list-style-type: none"> 1. Unplug the telephone cable from the telephone wall jack. 2. Connect a telephone to the jack, pick up the handset, and listen for a dial tone. If there is a dial tone, reconnect the modem to the telephone wall jack with the telephone cable and make sure all connections are secure. 3. If there is still no dial tone, contact your local phone company or building manager.
	The modem is not responding to commands from the computer keyboard.	<p>Verify the modem and computer are connected:</p> <ol style="list-style-type: none"> 1. Select Start → Programs → Accessories → HyperTerminal, then go to Terminal Mode. 2. Type AT and press the Enter key. If the modem displays OK, the modem and computer are working together. If the modem displays ERROR, or does not respond, restart the computer and repeat step 1. 3. Type ATDT and listen for dial tone. 4. Type ATH0 to hang up.

Continued

Table 2-15 *Continued*

Problem	Possible Cause	Solution
Modem does not connect at highest speed.	Line conditions in your area or in the area you are calling may not support the highest connect speeds.	Have your telephone line checked by your local telephone service provider. Try dialing an alternate telephone number for the service you are using.
	Another device on your telephone line may be causing interference.	Hang up an extension telephone and disconnect any other devices that may be using the same telephone line, then redial.
	The service or site called does not support 56K or supports an incompatible 56K implementation.	The standard internal modem supports the V.90 ITU Standard for 56K modems with backward compatibility to K56flex. To find an Internet Service Provider (ISP) who supports V.90 or K56flex protocols, go to the Compaq Web site at www.compaq.com .
	There is noise on the telephone line.	The 56K protocol of an internal modem will fall back to lower speeds if the telephone line is too noisy for a high-speed connection. Try using another telephone line. Change the Hang-up Delay S Register: 1. Select Start→ Programs →Accessories→ HyperTerminal. 2. Go to Command Mode, type ATS10=150, then press Enter . NOTE: This command causes the modem to take longer to disconnect even if there is no noise on the line.
The telephone line does not support 56K implementation.	The 56K protocol requires that the telephone line contain no more than one analog-to-digital conversion. Try connecting from an alternate site.	

Table 2-16
Solving PC Card Problems

Problem	Possible Cause	Solution
Computer does not beep when a PC Card is inserted.	PC Card is not inserted properly.	Try reinserting the card. Ensure that the PC Card is inserted in the correct orientation. Insert the card gently to prevent damage to the pins.
	Speakers are turned off or volume is turned down.	Adjust the volume control on the computer.
	PC Card or card driver is not PCMCIA compliant.	Check the list of PC Cards tested successfully in Compaq PC Card platforms.

Continued

Table 2-16 *Continued*

Problem	Possible Cause	Solution
Computer beeps only once when a PC Card is inserted.	The computer beeps once to indicate that a PC Card is recognized but not properly configured.	Before a new PC Card can be used, it may be necessary to perform an initial setup procedure. Follow the PC Card manufacturer's instructions for formatting a hard drive card or installing PC Card-specific drivers for a network card.
Network PC Card does not work.	Necessary drivers are not installed (turned on).	Refer to the instructions that came with the PC Card or contact the vendor for information on installing the correct drivers.
	PC Card is not fully inserted or is upside down.	Ensure the PC Card is inserted correctly.
	Network PC Card or driver is not PCMCIA compliant.	Check the list of PC Cards tested successfully in Compaq PC Card platforms.
Storage PC Card does not work.	SRAM and flash memory PC Cards require the memory card driver to be loaded.	Memory cards can only be accessed using DOS real mode drivers.
	You are trying to access the storage PC Card using the wrong drive letter.	If you are running Windows 95, change the drive letter assignment in Device Manager If you are running Windows NT 4.0, change the drive letter assignment through the Control Panel.
	The PC Card is not formatted.	For memory cards, run MCFORMAT in MS-DOS Mode to format the PC Card. For ATA cards, run ATAINIT, then run MCFORMAT in MS-DOS Mode to format the PC Card.
	The card is not supported.	Check the list of PC Cards tested successfully in Compaq PC Card platforms.
	Storage cards, such as SRAM, do not work in the expansion base.	Use the storage card in the computer.

**Table 2-17
Solving Power Problems**

Problem	Possible Cause	Solution
Computer will not turn on.	Battery is discharged and computer is not connected to a power source.	<ul style="list-style-type: none"> ■ Charge the battery pack. ■ Replace the battery pack. ■ Connect the computer to an external power source.
	Battery is discharged and cables to the external power source are unplugged.	Ensure that cables connecting the computer and the external power source are plugged in properly.
Computer turned off while it was left unattended.	Computer initiated because of a critical low battery condition.	<ul style="list-style-type: none"> ■ Charge the battery pack. ■ Replace the battery pack. ■ Connect the computer to an external power source.
	The computer initiated Hibernation after a user-defined timeout expired.	Turn on the computer.

**Table 2-18
Solving Screen Problems**

Problem	Possible Cause	Solution
Characters on computer display are dim.	Computer is in direct light.	Move the computer or adjust the screen.
	The brightness control is not set properly.	Adjust the brightness control by pressing the Fn+F10 hotkeys.
	You may have a screen saver or screen blanking utility installed.	Press any key to refresh the screen.
	Screen timeout was initiated.	Press any key to light the screen.
	System initiated Suspend after a user-defined timeout expired.	Press the suspend button to exit Suspend.
	Computer initiated a low battery Suspend or Hibernation.	<ul style="list-style-type: none"> ■ Replace the battery pack and exit Suspend or Hibernation. ■ Connect the computer to an external power source and exit Suspend or Hibernation.
Computer screen is blank and external monitor displays information.	Power Management, which controls Suspend and Hibernation, is disabled and the battery pack has discharged.	<ul style="list-style-type: none"> ■ Replace the battery pack and turn on the computer. ■ Connect the computer to an external power source and turn on the computer.
	Display was switched to the external monitor.	Press Fn+F4 to display information on the computer screen; press Fn+F4 again to display information simultaneously on both screens.
Fn+F4 hotkey combination does not switch between internal and external displays.	Display switch is stuck.	Tap the switch.
	CRT or other display device is not connected properly.	Check your connections to ensure that an external device is connected properly.

Table 2-19
Solving USB Problems

Problem	Possible Cause	Solution
External device connected to a USB connector does not work.	The operating system limits external devices connected by USB to two tiers which can include no more than two hubs on the first tier and no more than one keyboard and one pointing device on the first or second tier.	Reduce the number of connected external USB devices to no more than two hubs on the first tier, and no more than one keyboard and one pointing device on the first or second tier.
External device connected to USB connector does not work during startup (before Windows 95 loads).	During startup, only two tiers are supported by the USB port. These tiers can include no more than two hubs on the first tier and no more than one keyboard and one pointing device on the first or second tier.	Use the external device only after Windows 95 or Windows 98 has loaded. Reduce the number of connected external USB devices to no more than two hubs on the first tier, and no more than one keyboard and one pointing device on the first or second tier.
External devices in lower tiers do not work.	An unpowered hub is connected to another unpowered hub.	Use only powered hubs. Make sure that all unpowered hubs are immediately preceded by powered hubs in the USB chain.

chapter 3

ILLUSTRATED PARTS CATALOG

This chapter provides an illustrated parts breakdown and a reference for spare part numbers for components of the Compaq Armada M300.

3.1 Serial Number Location

When ordering parts or requesting information, provide the computer serial number and model number located on the bottom of the computer (Figure 3-1).

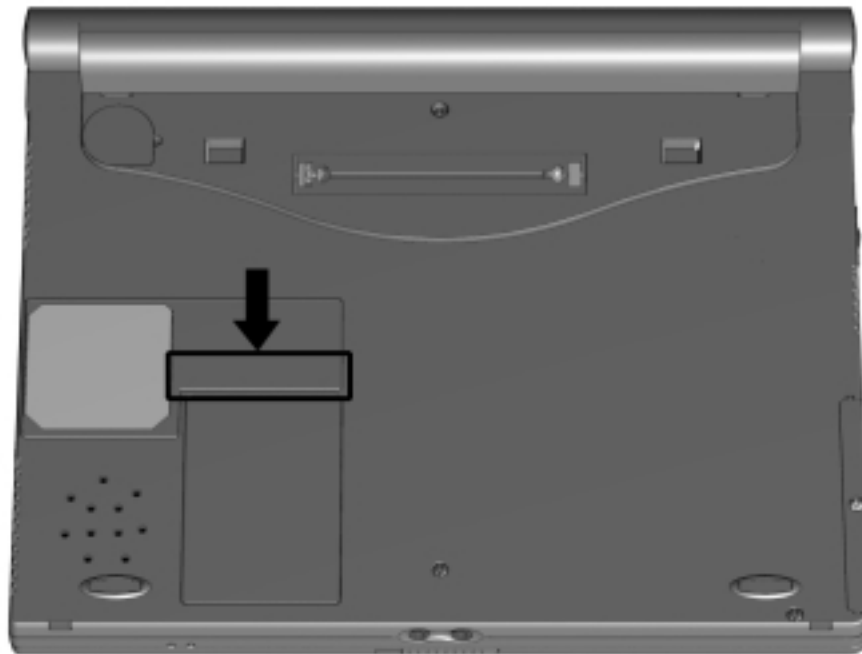

Figure 3-1. Serial Number Location

3.2 Computer Major System Components

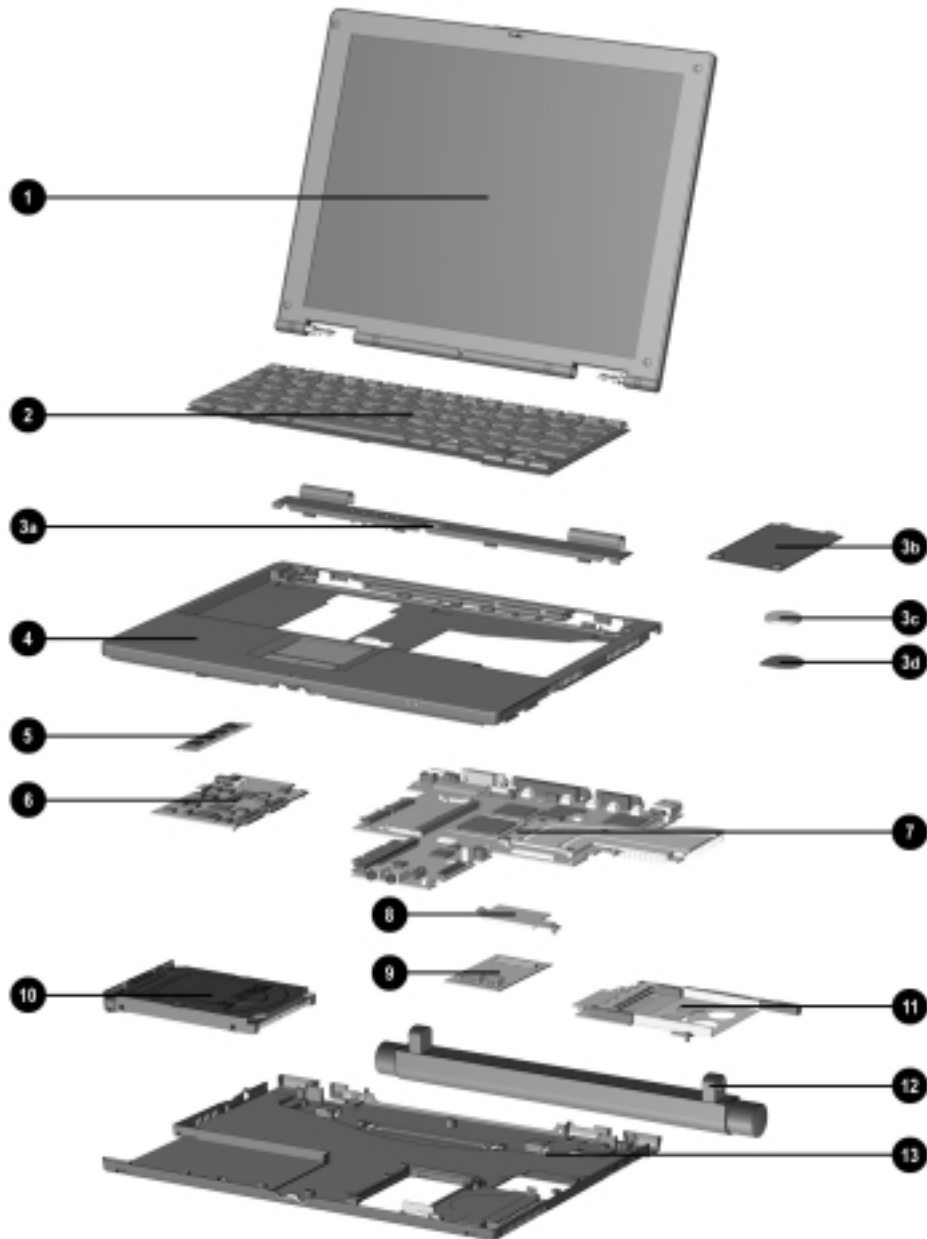

Figure 3-2. Major System Components

**Table 3-1
Spare Parts: Computer System Major Components**

Item	Description	Spare Part Number
1	Display assembly	
	11.3-inch, XGA, CTFT (SKU#'s 165288-XXX only)	171969-001
	11.3-inch, SVGA, CTFT	178654-001
2	Keyboard	140375-XXX
	Belgian -181	Italian -061 Portuguese -131
	Brazilian -201	International -003 Spanish -071
	Danish -081	Japanese -191 Swiss -111
	Finnish -101	Korean -AD1 Taiwanese -AB1
	French -051	Latin American U.K. English -031
	French Canadian -121	Spanish -161 U.S. English/
	German -041	Norwegian -091 Canadian -001
		Miscellaneous Plastic Kit
3a	Switch cover	
3b	Modem cover	
3c	Real time clock (RTC) battery	
3d	RTC battery cover	
4	Top cover with TouchPad	140381-001
5	Memory expansion board	
	256 MB	167136-001
	128 MB	135244-001
	64 MB	135243-001
	32 MB	135242-001
6	Voltage converter board	136251-001
7	Processor board assembly	
	Intel Pentium III 500 MHz	171968-001
	Intel Celeron 450 MHz	171967-001
	Intel Pentium II 333 MHz	136250-001
	Intel Celeron 333 MHz	136248-001
8	Modem connector board	140385-001
9	Mini PCI modem board, V.90, Type-I	121896-001
	Mini PCI combination modem/network interface card (NIC), V.90, Type-I	153107-001
10	Hard drive	
	12.0 GB	171971-001
	6.4 GB	136246-001
	4.3 GB	136245-001
11	PC Card Assembly	140384-001
12	Battery pack, Li-ion	136244-001
	High capacity battery pack	155065-001
13	CPU base enclosure	103755-001
	LED board (not illustrated)	168641-001

3.3 Miscellaneous Plastic Kit Components

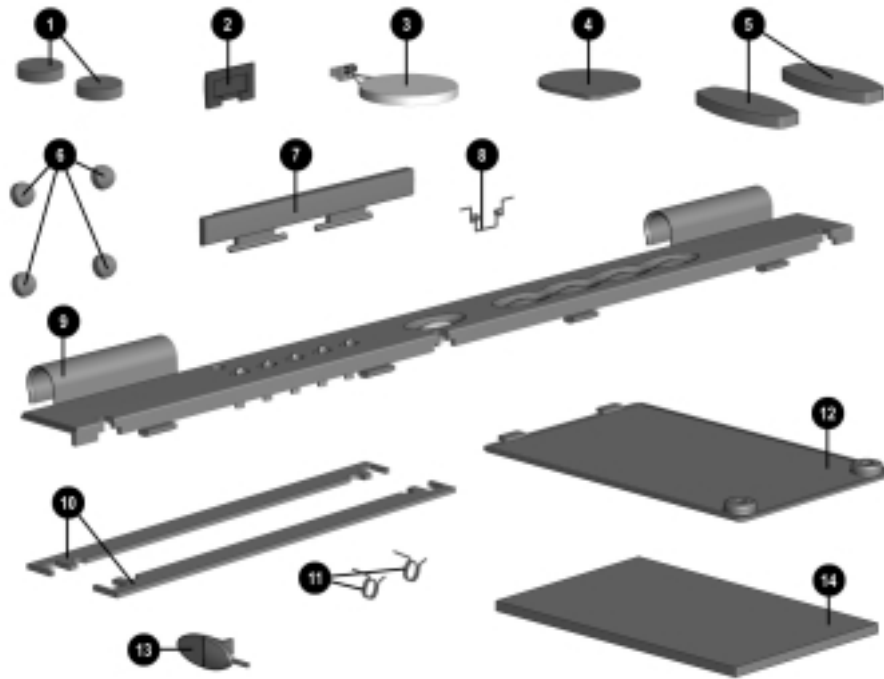

Figure 3-3. Miscellaneous Plastic Kit Components

Table 3-2
Spare Parts: Miscellaneous Plastic Kit Components
Spare Part Number 136254-001

Item	Description
1	Back rubber feet
2	Infrared lens
3	RTC (Real Time Clock) battery
4	RTC (Real Time Clock) battery cover
5	Front rubber feet
6	Display screw covers
7	PC Card door
8	PC Card door spring
9	Switch cover
10	Docking bay doors
11	Docking bay door springs
12	Modem cover
13	Power button
14	Modem card dummy

3.4 Mass Storage Devices

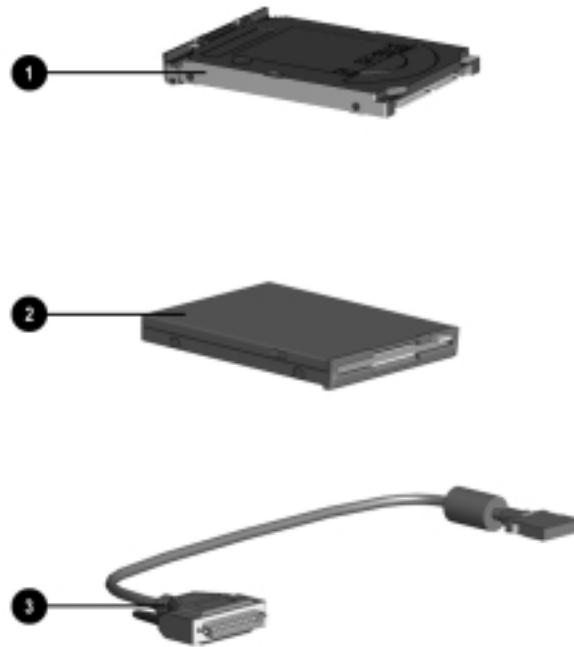

Figure 3-4. Mass Storage Devices

Table 3-3
Spare Parts: Mass Storage Devices

Item	Description	Spare Part Number
1	Hard drive	
	12.0 GB	171971-001
	6.4 GB	136246-001
	4.3 GB	136245-001
2	External diskette drive, 1.44-megabyte, 3.5 inch/8.89 cm	136256-001
3	External diskette drive cable	140383-001
*	4X DVD-ROM drive (for use with Mobile Expansion Unit)	102266-001
*	SuperDisk LS-120 drive (for use with Mobile Expansion Unit)	327456-003
*	24X Max CD-ROM drive (for use with Mobile Expansion Unit)	315082-002

* Not illustrated

3.5 Miscellaneous

Table 3-4
Spare Parts: Miscellaneous (not illustrated)

Description			Spare Part Number
Mobile Expansion Unit			140382-001
Armada M300 <i>Maintenance & Service Guide</i>			158340-001
PC Card modem			105993-001
Battery Charger			277734-001
AC Power Cord			246959-XXX
Australian	246959-011	Japanese	246959-291
Danish	246959-081	Korean	246959-AD1
European/Middle		Swiss	246959-AG1
Eastern/African	246959-021	U.K. English	246959-031
Italian	246959-061	U.S. English	246959-001
External AC Adapter			163444-001
Return Kit			136257-001
Miscellaneous Screw Kit			136255-001
Modem, 56K, V.90 with integrated NIC			153107-001
Modem, 56K, V.90			121896-001
Hard drive adapter			155352-001
Battery charger			153991-001

chapter 4

REMOVAL AND REPLACEMENT PRELIMINARIES

This chapter provides essential information for proper and safe removal and replacement service.

4.1 Tools Required

You will need the following tools to complete the removal and replacement procedures:

- Magnetic Torx T-8 screwdriver (for all screws unless otherwise specified)
- 9/32-inch socket for bushing guides

4.2 Service Considerations

Listed below are some of the considerations that you should keep in mind during disassembly and assembly procedures.

Plastic Parts

Using excessive force during disassembly and reassembly can damage plastic parts. Use care when handling the plastic parts. Apply pressure only at the points designated in the maintenance instructions.

IMPORTANT: As you remove each subassembly from the computer, place it (and all accompanying screws) away from the work area to prevent damage.

Cables and Connectors

Cables must be handled with extreme care to avoid damage. Apply only the tension required to unseat or seat the cables during removal and insertion. Handle cables by the connector whenever possible. In all cases, avoid bending, twisting, or tearing cables. Ensure that cables are routed in such a way that they cannot be caught or snagged by parts being removed or replaced. Handle flex cables with extreme care; they tear easily.



CAUTION: When servicing the computer, ensure that cables are placed in their proper location during the reassembly process. Improper cable placement can damage the computer.

4.3 Preventing Damage to Removable Drives

Removable drives are fragile components that must be handled with care. To prevent damage to the computer or a removable drive, or loss of information, observe these precautions:

- Before removing or inserting a hard drive, shut down the computer. If you are unsure whether the computer is off or in Hibernation, turn the computer on, then shut it down.
- Before removing a diskette drive, CD-ROM drive, SuperDisk LS-120 drive, or a DVD-ROM drive, ensure that a diskette or disc is *not* in the drive. Ensure that the drive tray is closed.
- Before handling a drive, ensure that you are discharged of static electricity. While handling a drive, avoid touching the connector.
- Handle drives on surfaces that have at least one inch of shock-proof foam.
- Avoid dropping drives from any height onto any surface.
- Do not use excessive force when inserting a drive into a drive bay.
- Avoid exposing a hard drive to products that have magnetic fields such as monitors or speakers.
- Avoid exposing a drive to temperature extremes or to liquids.
- If a drive must be mailed, ship it in a suitable form of protective packaging. Shipping the drive in standard packaging may not cushion it from destructive shock, vibration, temperature, or humidity. Place a mailing label with the wording “Fragile: Handle With Care” on the mailer.
- After the hard drive has been removed from the computer, avoid turning the hard drive and tray upside down. The drive is not secured to the tray and can fall out.
- Do not place labels on the ventilation area on the hard drive.
- Heed the labels on the hard drive.

4.4 Preventing Electrostatic Damage

Many electronic components are sensitive to electrostatic discharge (ESD). Circuitry design and structure determine the degree of sensitivity. Networks built into many integrated circuits provide some protection, but in many cases the discharge contains enough power to alter device parameters or melt silicon junctions.

A sudden discharge of static electricity from a finger or other conductor can destroy static-sensitive devices or microcircuitry. Often the spark is neither felt nor heard, but damage occurs. An electronic device exposed to electrostatic discharge may not be affected at all and can work perfectly throughout a normal cycle. Or it may function normally for a while, then degrade in the internal layers, reducing its life expectancy.

Packaging and Transporting Precautions

Use the following grounding precautions when packaging and transporting equipment:

- To avoid hand contact, transport products in static-safe containers such as tubes, bags, or boxes.
- Protect all electrostatic-sensitive parts and assemblies with conductive or approved containers or packaging.
- Keep electrostatic-sensitive parts in their containers until they arrive at static-free workstations.
- Place items on a grounded surface before removing them from their container.
- Always be properly grounded when touching a sensitive component or assembly.
- Place reusable electrostatic-sensitive parts from assemblies in protective packaging or non-conductive foam.
- Use transporters and conveyers made of antistatic belts and roller bushings. Ensure that mechanized equipment used for moving materials is wired to ground, and that proper materials are selected to avoid static charging. When grounding is not possible, use an ionizer to dissipate electric charges.

Workstation Precautions

Use the following grounding precautions at workstations:

- Cover the workstation with approved static-dissipative material (refer to Table 4-2 later in this chapter).
- Use a wrist strap connected to a properly grounded work surface and use properly grounded tools and equipment.
- Use field service tools, such as cutters, screwdrivers, and vacuums that are conductive.
- When using fixtures that must directly contact dissipative surfaces, use fixtures made of static-safe materials only.
- Keep work area free of nonconductive materials such as ordinary plastic assembly aids and Styrofoam.
- Handle electrostatic-sensitive components, parts, and assemblies by the case or PCM laminate. Handle them only at static-free workstations.
- Avoid contact with pins, leads, or circuitry.
- Turn off power and input signals before inserting or removing connectors or test equipment.

Grounding Equipment and Methods

Grounding equipment must include either a wrist strap or a foot strap at a grounded workstation.

- When seated, wear a wrist strap connected to a grounded system. Wrist straps are flexible straps with a minimum of one megohm $\pm 10\%$ resistance in the ground cords. To provide proper ground, a strap must be worn snug against the skin. On grounded mats with banana-plug connectors, connect a wrist strap with alligator clips.
- When standing, use foot straps and a grounded floor mat. Foot straps (heel, toe, or boot straps) can be used at standing workstations and are compatible with most types of shoes or boots. On conductive floors or dissipative floor mats, use foot straps on both feet with a minimum of one-megohm resistance between the operator and ground. To be effective, the conductive strips must be worn in contact with the skin.

Other grounding equipment recommended for use in preventing electrostatic damage include:

- Antistatic tape
- Antistatic smocks, aprons, or sleeve protectors
- Conductive bins and other assembly or soldering aids
- Non-conductive foam
- Conductive tabletop workstations with ground cord of one-megohm resistance
- Static-dissipative table or floor mats with hard tie to ground
- Field service kits
- Static awareness labels
- Material-handling packages
- Non-conductive plastic bags, tubes, or boxes
- Metal tote boxes

Electrostatic Voltage Levels and Protective Materials

Table 4-1 shows how humidity affects the electrostatic voltage levels generated by different activities.

Table 4-1			
Typical Electrostatic Voltage Levels			
Event	Relative Humidity		
	10%	40%	55%
Walking across carpet	35,000 V	15,000 V	7,500 V
Walking across vinyl floor	12,000 V	5,000 V	3,000 V
Motions of bench worker	6,000 V	800 V	400 V
Removing DIPS from plastic tube	2,000 V	700 V	400 V
Removing DIPS from vinyl tray	11,500 V	4,000 V	2,000 V
Removing DIPS from Styrofoam	14,500 V	5,000 V	3,500 V
Removing bubble pack from PCB	26,500 V	20,000 V	7,000 V
Packing PCBs in foam-lined box	21,000 V	11,000 V	5,000 V

NOTE: 700 volts can degrade a product.

Table 4-2 lists the shielding protection provided by antistatic bags and floor mats.

Table 4-2		
Static-Shielding Materials		
Material	Use	Voltage Protection Level
Antistatic plastic	Bags	1,500 V
Carbon-loaded plastic	Floor mats	7,500 V
Metallized laminate	Floor mats	15,000 V

chapter 5

REMOVAL AND REPLACEMENT PROCEDURES

5.1 Serial Number

The computer serial number should be reported to Compaq when requesting information or ordering spare parts. The serial number is located on the bottom of the computer (Figure 5-1).

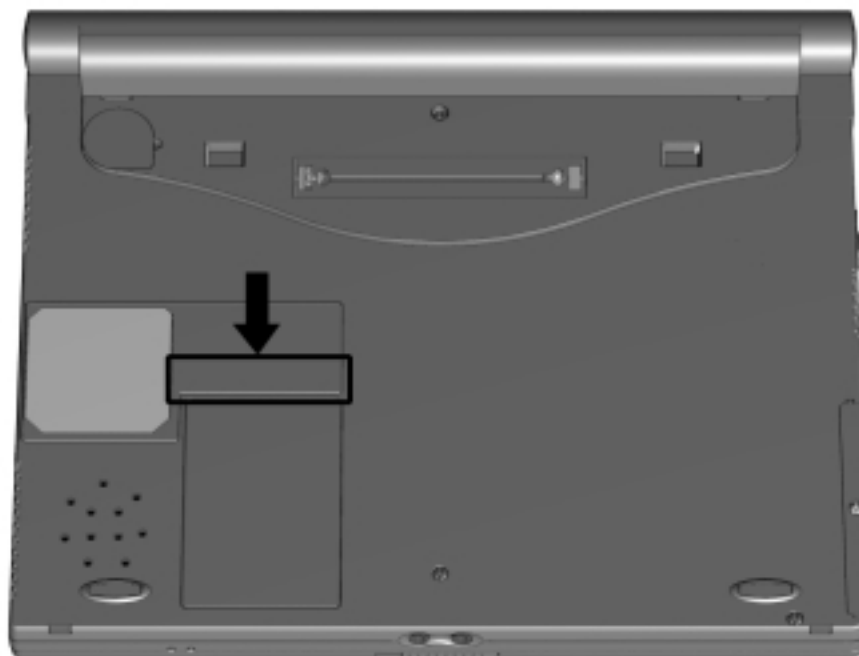

Figure 5-1. Serial Number Location

5.2 Disassembly Reference Chart

Use the chart below to determine the section number to be referenced when removing components from the computer.

5.3	Disconnecting the Computer from the Mobile Expansion Unit
5.4	Disconnecting the Computer
5.5	Preparing the Computer for Disassembly
5.6	Battery Packs
	Removing the Battery Pack
	Replacing the Battery Pack
5.7	Hard Drives
	Removing a Hard Drive
	Inserting a Hard Drive
5.8	PC Cards
	Removing a PC Card
	Inserting a PC Card
5.9	Modem or Modem/NIC Card
5.10	Real Time Clock Battery
5.11	Keyboard
5.12	Memory Expansion
	Removing Memory Expansion Boards
	Installing Memory Expansion Boards
5.13	Switch Cover
5.14	Display Assembly
5.15	Top Cover with TouchPad
5.16	Voltage Converter Board
5.17	Modem Connector Board
5.18	PC Card Connector
5.19	Processor/System Board Assembly

Figure 5-2. Disassembly Reference Chart

5.3 Disconnecting the Computer from the Mobile Expansion Unit

1. Turn off the computer.
2. Close the display.
3. Turn off and disconnect all external devices connected to the computer.
4. On the mobile expansion unit, press the docking release button **1** to release the expansion unit from the computer (Figure 5-3).
5. Lift the rear end of the computer to disconnect it from the computer expansion connector **2**.
6. Pull the computer away from the mobile expansion unit tabs.

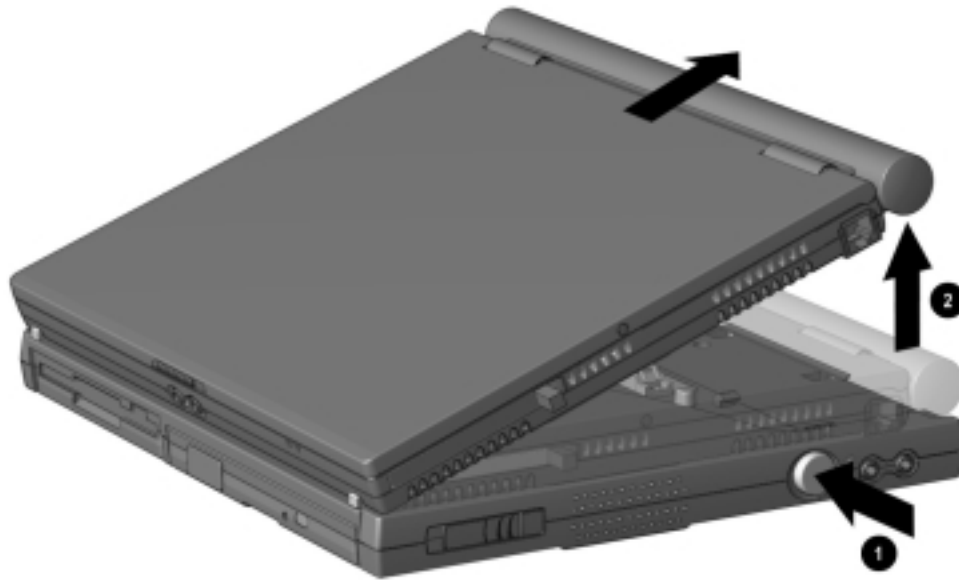

Figure 5-3. Disconnecting the Computer from the Mobile Expansion Unit

5.4 Disconnecting the Computer

1. Disconnect the AC power cord from the AC adapter ❶ (Figure 5-4).
2. Unplug the power cord from the electrical outlet ❷.
3. Disconnect the AC adapter from the power connector on the left side of computer ❸.

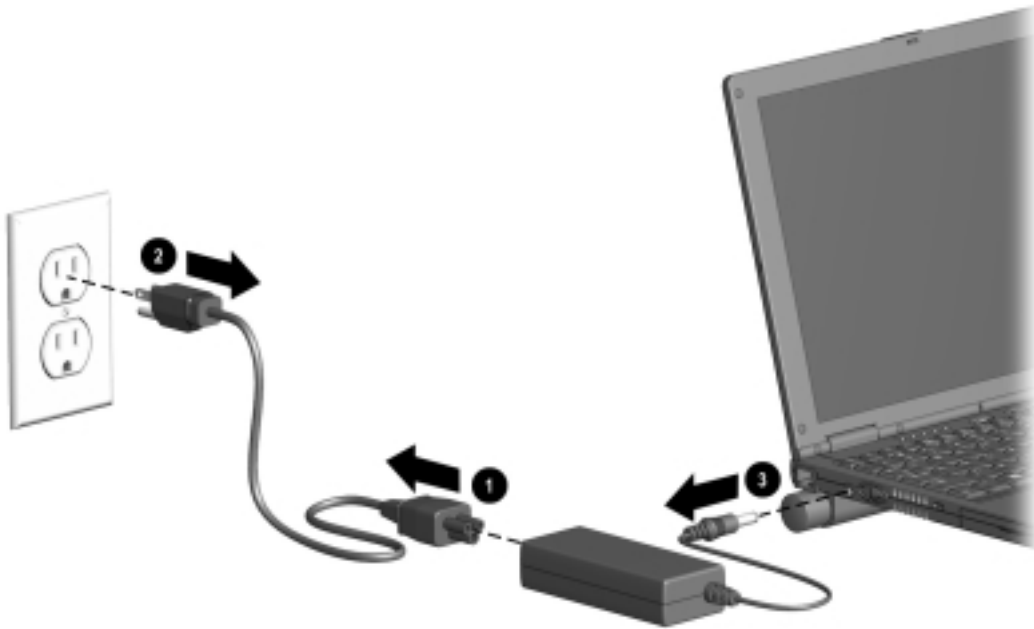

Figure 5-4. Disconnecting the Computer

5.5 Preparing the Computer for Disassembly

1. Disconnect the computer from the mobile expansion unit.
2. Shut down the computer.
3. Disconnect the AC adapter and all external devices connected to the computer.
4. Remove the battery pack (Section 5.6).



CAUTION: Failure to disconnect the AC Adapter from the computer and to remove the battery pack before removing and installing internal components can damage the equipment.

5. Remove the hard drive (Section 5.7).
6. Remove all PC Cards (Section 5.8).

5.6 Battery Packs



WARNING: To reduce the risk of injury or damage to the battery pack, do not crush, puncture, or incinerate the battery pack or short the metal contacts. Do not attempt to open or service the battery pack.

Removing the Battery Pack

1. Shut down the computer.
2. Turn the computer upside down.
3. Tilt the battery pack so it lies flat.
4. Slide in the two battery latches toward each other ❶ (Figure 5-5).
5. Rotate the battery pack 90 degrees toward the computer ❷, and lift up the battery pack from the computer ❸.

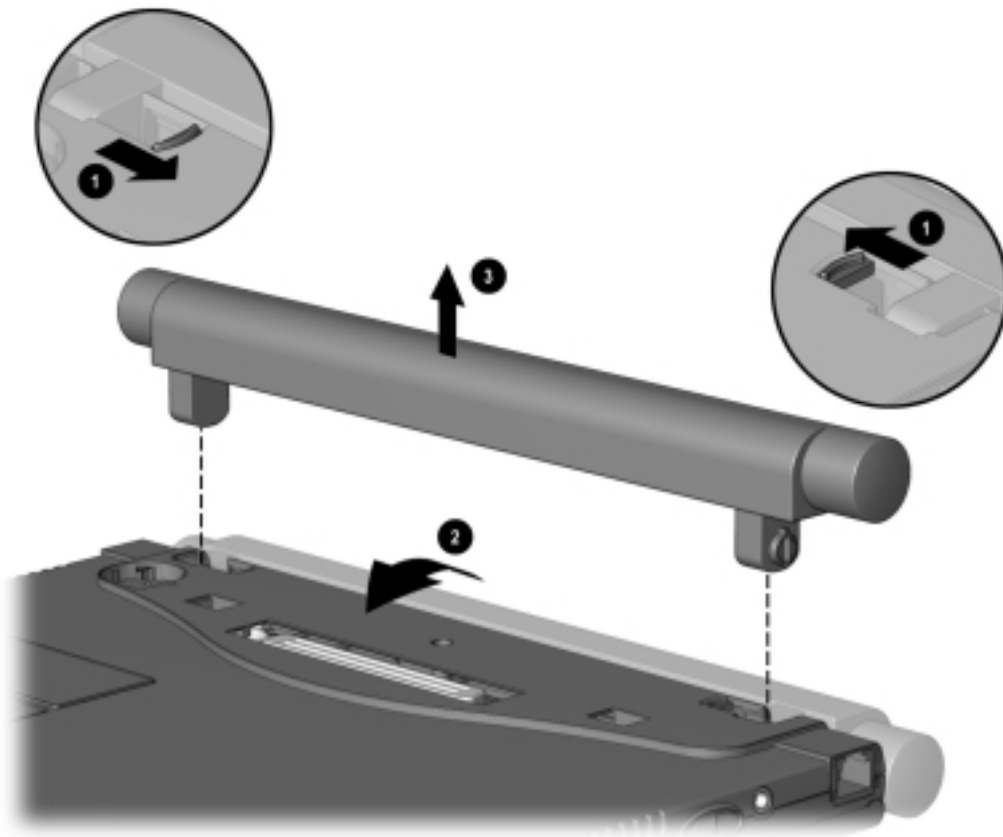

Figure 5-5. Removing the Battery Pack

Replacing the Battery Pack



WARNING: To prevent damage to the computer, do not insert a battery pack until the computer is fully reassembled.

1. Turn the computer upside down.
2. Push the battery pack onto the computer until the contacts connect ❶, and rotate the battery pack 90 degrees toward the back of the computer ❷ (Figure 5-6).
3. Slide the two battery latches out (away from each other) ❸.

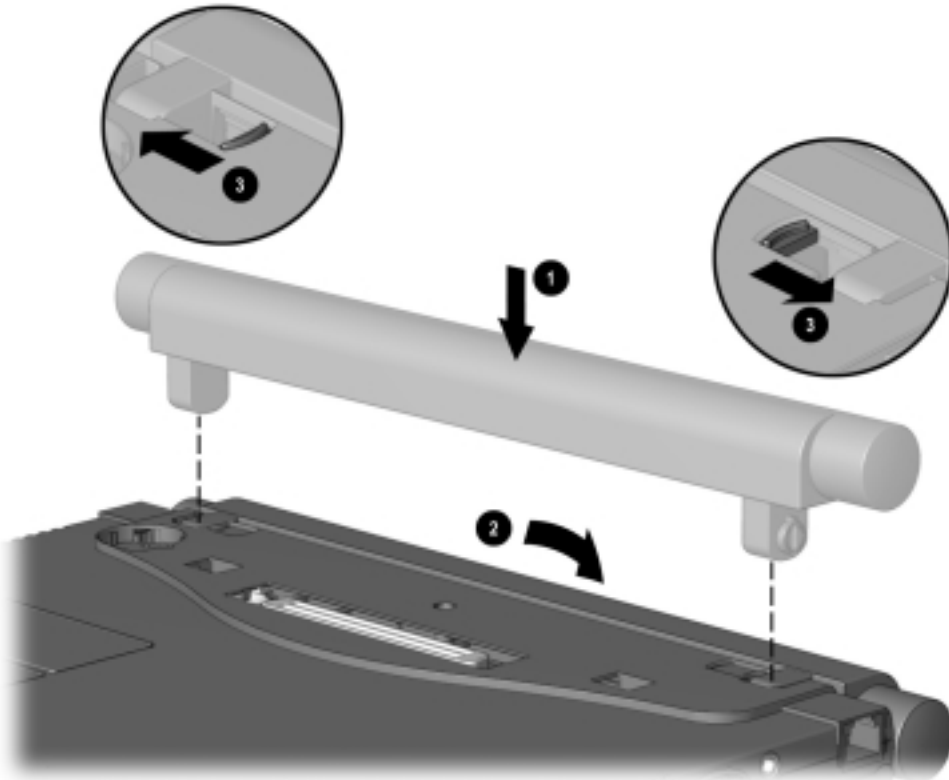

Figure 5-6. Replacing the Battery Pack

5.7 Hard Drives

Removing a Hard Drive

Before removing a hard drive, back up all information on the hard drive.

1. Shut down the computer.
2. Turn the computer upside down.
3. Remove the hard drive screw ❶ (Figure 5-7).
4. Pull up on the front bezel ❷.
5. Slide the hard drive out of the bay ❸.

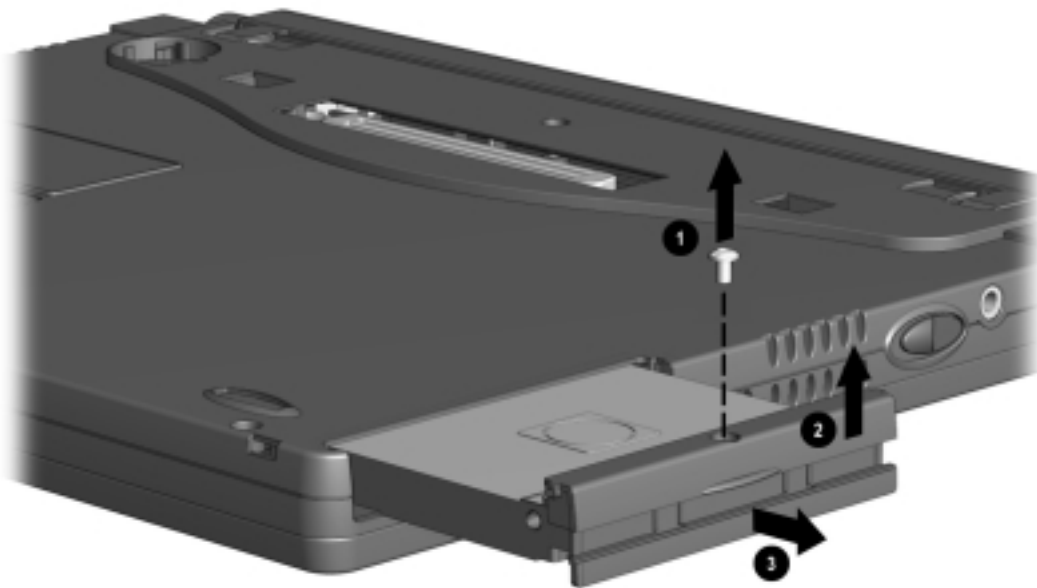

Figure 5-7. Removing a Hard Drive

Inserting a Hard Drive

1. Shut down the computer.
2. Turn the computer upside down.
3. Pull the bottom half of the bezel down.
4. Slide the hard drive into the bay until the connector is seated **1** (Figure 5-8).
5. Push the front bezel down **2**.
6. Insert the hard drive screw **3**.

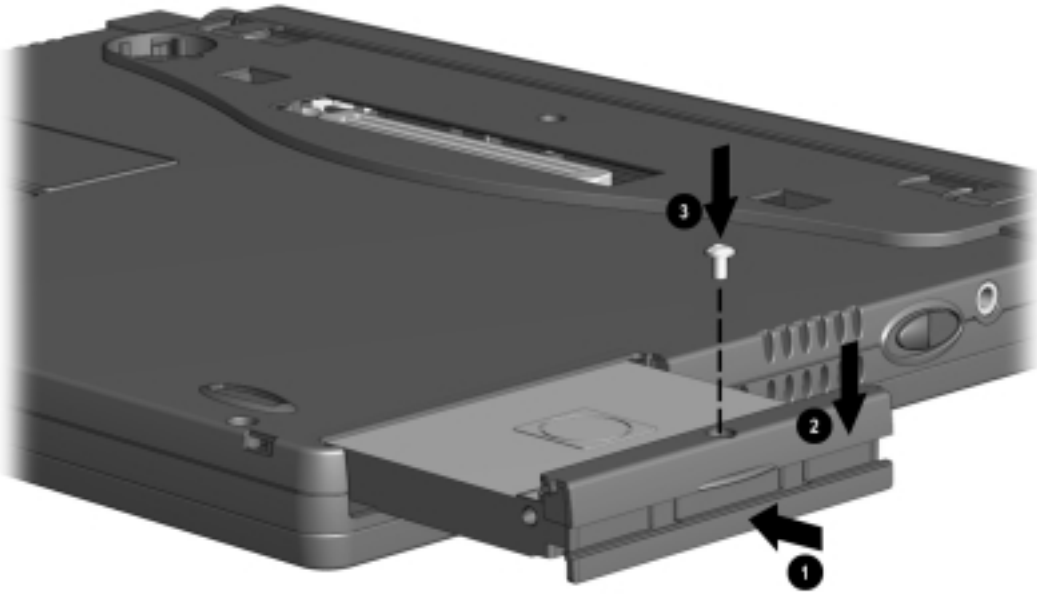

Figure 5-8. Inserting a Hard Drive

5.8 PC Cards

The procedure for removing PC Cards varies with the operating system being used and with the kind of PC Card being removed.

In Windows 95 or Windows 98—

- If you insert a PC Card while the computer is on, the computer beeps twice when the card is ready for use.
- If you remove a PC Card while the computer is on, the computer beeps twice when the card is removed.
- When a PC Card is in the system, the PC Card icon displays on the taskbar.

In Windows NT 4.0 with CardWare from Compaq—

- If you insert a PC Card while the computer is on, the computer beeps three times when the card is recognized.
- If you remove a PC Card while the computer is on, the computer beeps three times when the card is removed.
- The PC Card icon displays in the taskbar whether or not a PC Card is in the system.

Removing a PC Card

First, prepare the system for the removal:



CAUTION: If the computer is on and running Windows 95, failure to stop a PC Card before removing it may cause loss of data.

- **In Windows 95 or Windows 98**—If the computer is on, stop the PC Card before you remove it. To stop a PC Card, select the PC Card icon in the taskbar, then select the PC Card you want to stop. A message displays when the PC Card can be safely removed.
- **In Windows NT 4.0 with CardWare provided by Compaq**—If the computer is on, you must shut it down before removing some PC Cards. Refer to the PC Card documentation for removal requirements. Second, remove the PC Card:
 1. Press the PC Card eject button ❶ (Figure 5-9).
 2. Gently grasp the card and pull it out ❷.

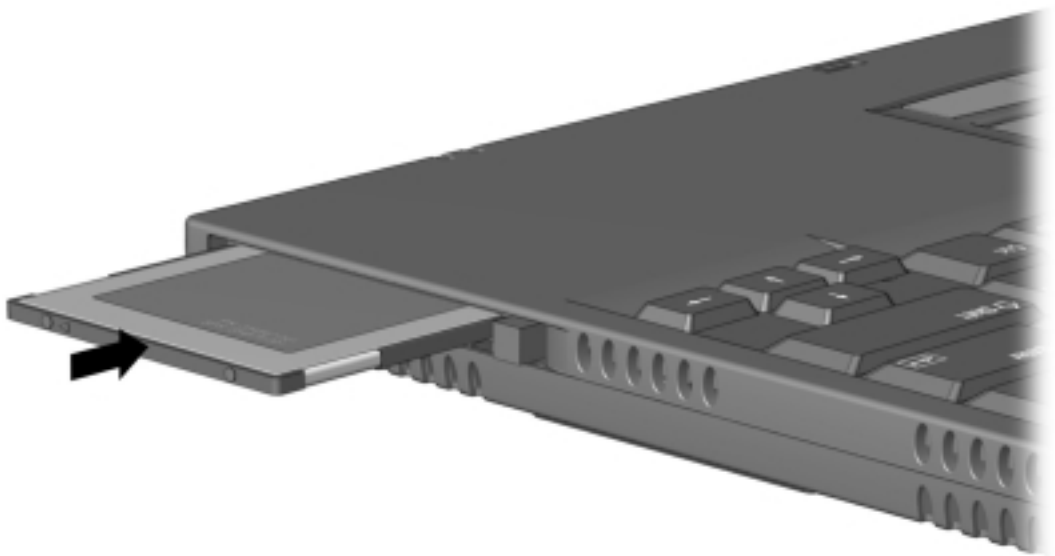

Figure 5-9. Removing a PC Card

Inserting a PC Card



CAUTION: To prevent damage to the connectors, use minimal pressure as you insert a PC Card into the PC Card slot.

1. With the connector facing the computer and the label side up, insert the PC Card in the slot, aligning the card on the two guide rails inside the PC Card slot (Figure 5-10).
2. Gently push the card into the slot until the card is seated.

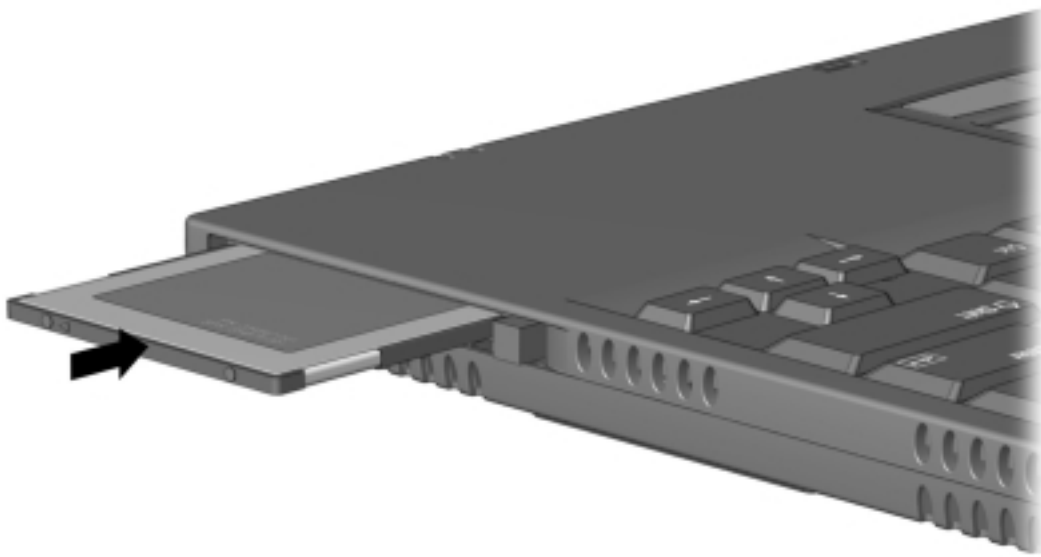

Figure 5-10. Inserting a PC Card

5.9 Modem or Modem/NIC Card

1. Prepare the computer for disassembly (Section 5.5).
2. If attached, disconnect the RJ-11 and RJ-45 cables from the computer.
3. Turn the computer upside down with the front facing forward.
4. Remove the two screws that secure the modem or modem/NIC card cover to the base assembly ❶ (Figure 5-11).
5. Lift the front edge of the cover and swing it back ❷.
6. Remove the cover ❸.

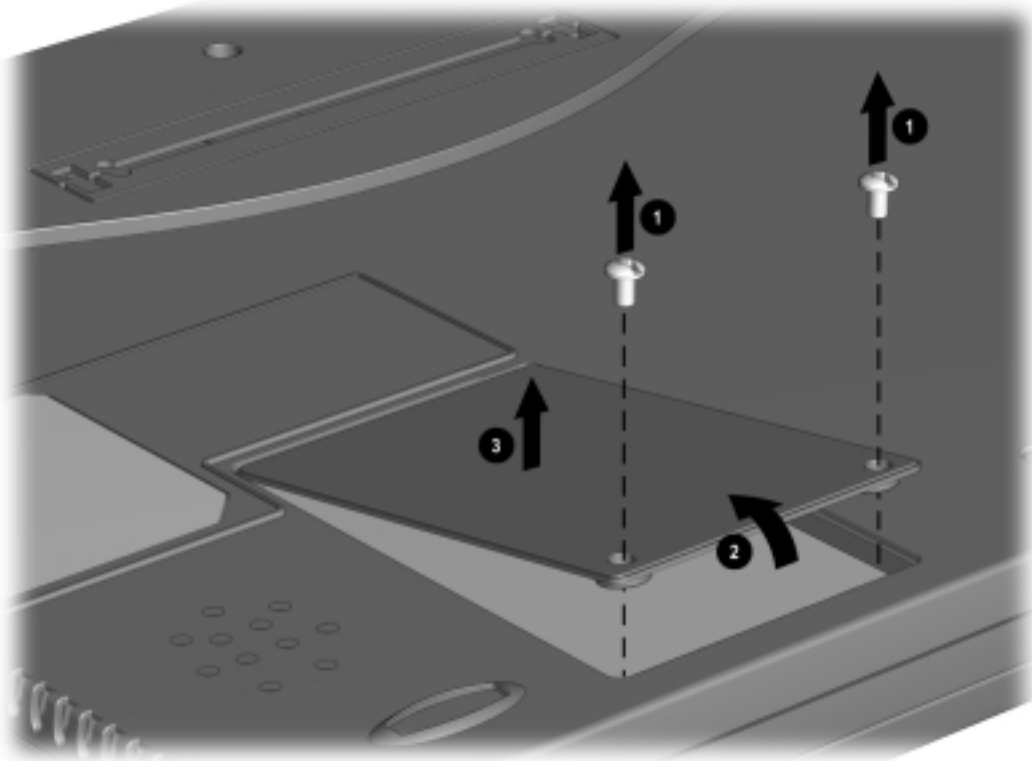

Figure 5-11. Removing the Modem or Modem/NIC Card Cover

7. Lift up on the back of the modem or modem/NIC card ❶, and swing it forward to disconnect it from the system board ❷ (Figure 5-12).
8. Use the connector removal tool to disconnect all cables connected to the card ❸.
9. Remove the card.

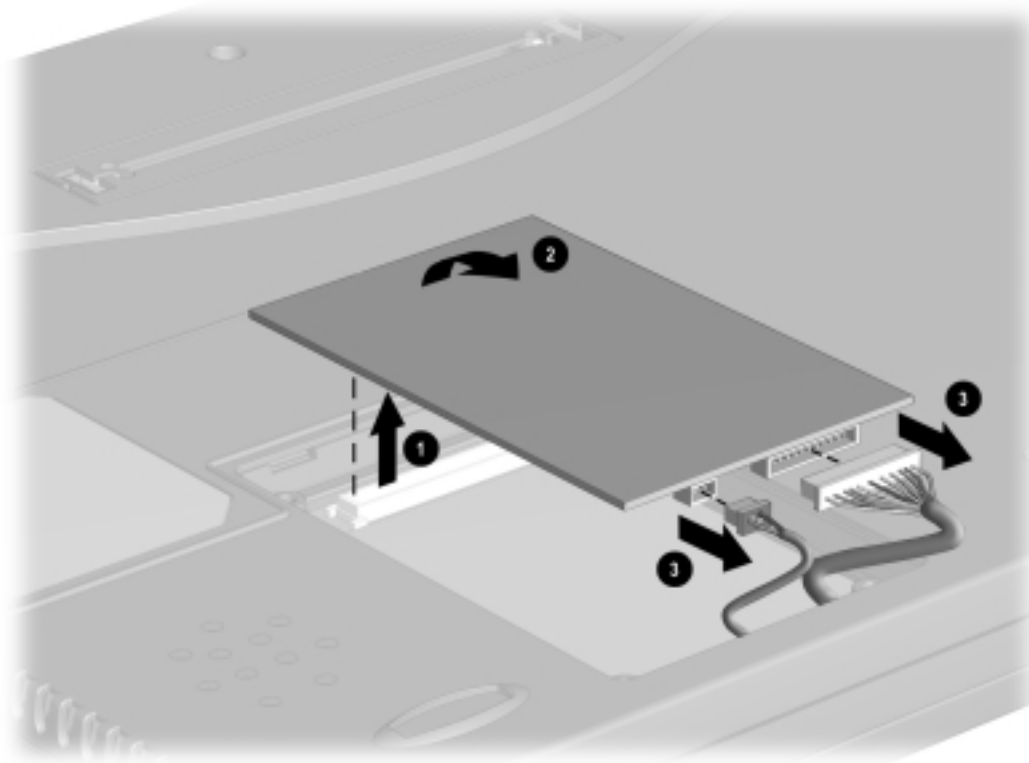

Figure 5-12. Removing the Modem or Modem/NIC Card

Reverse the above procedure to install the modem or modem/NIC card.

5.10 Real Time Clock (RTC) Battery

1. Prepare the computer for disassembly (Section 5.5).
2. Turn the computer upside down with the rear panel facing forward.
3. Remove the RTC battery cover by lifting it at the indentation ❶ (Figure 5-13).
4. Remove the battery from the base enclosure ❷.
5. Use the connector removal tool to disconnect the RTC battery cable from the system board ❸.
6. Remove the battery.

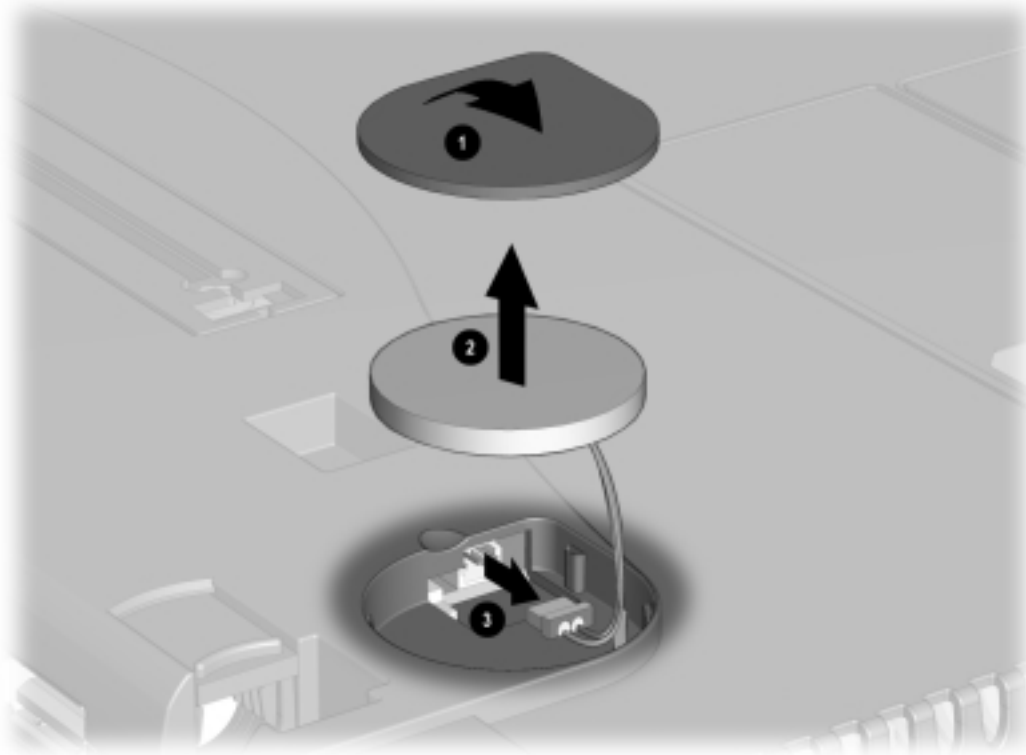

Figure 5-13. Removing the RTC Battery

Reverse the above procedure to install the RTC battery.

5.11 Keyboard

1. Prepare the computer for disassembly (Section 5.5).
2. Press down on each of the three release tabs **1** along the top edge of the keyboard (Figure 5-14).
3. Swing the top edge of the keyboard up and forward **2**.

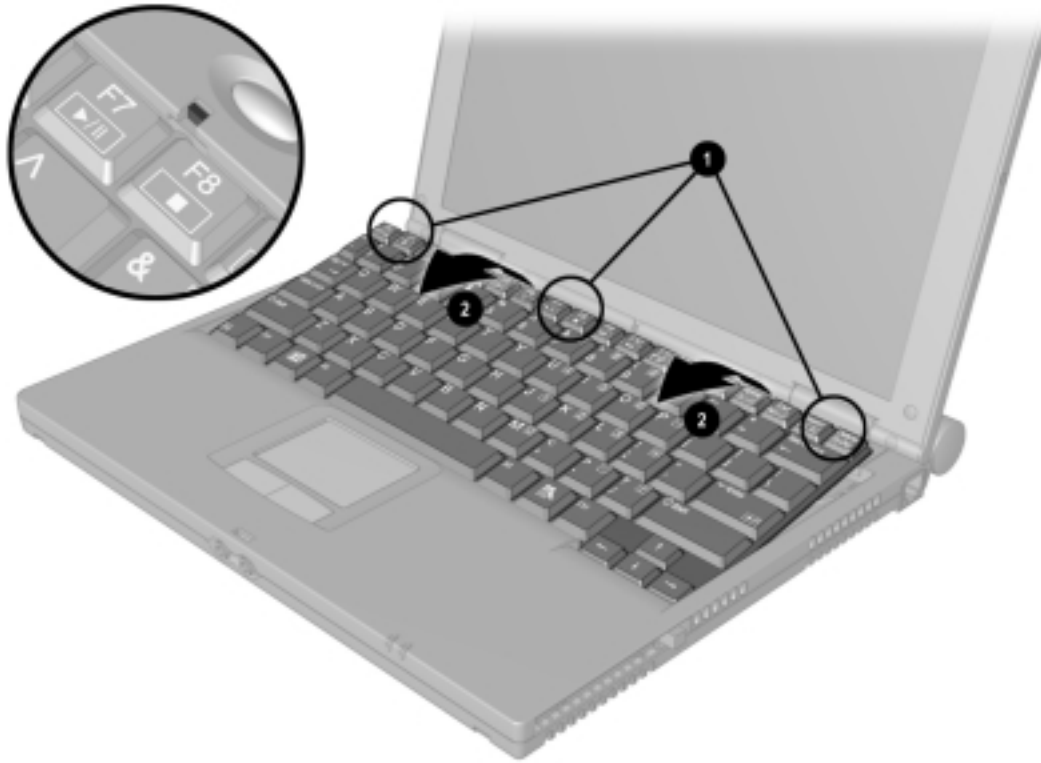

Figure 5-14. Releasing the Keyboard

4. Use the connector removal tool to release the keyboard cable from the ZIF connector ❶ (Figure 5-15).
5. Use the connector removal tool to disconnect the keyboard cable ❷.
6. Remove the keyboard.

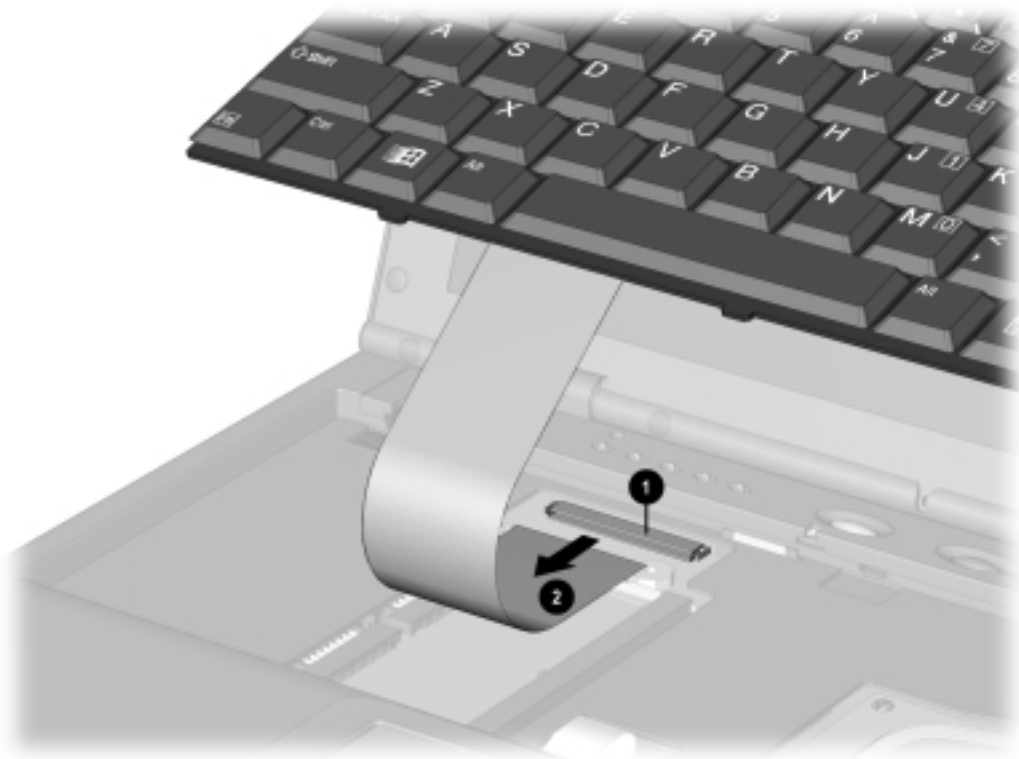

Figure 5-15. Disconnecting the Keyboard Cable

Reverse the above procedure to install the keyboard.

5.12 Memory Expansion

Removing the Memory Expansion Board



WARNING: Failure to unplug the power cord and to remove the battery pack before installing a memory expansion board can damage the equipment and expose you to the risk of electrical shock.



CAUTION: Electrostatic discharge (ESD) can damage electronic components. Before beginning this procedure, ensure that you are properly grounded. For more information, refer to "Preventing Electrostatic Damage" in Chapter 4.

NOTE: There is only one memory expansion slot in the computer. Before upgrading memory, you must remove the memory board that came with the computer.

1. To remove the memory board, pull away the plastic retention clips on each side of the memory board ❶. The memory expansion board tilts upward (Figure 5-16).
2. Lift the edge of the memory expansion board and slide it gently out of the memory expansion slot at a 45-degree angle ❷.
3. If applicable, turn back the memory insulator.
4. Place the removed memory expansion board in an electrostatic-safe container.

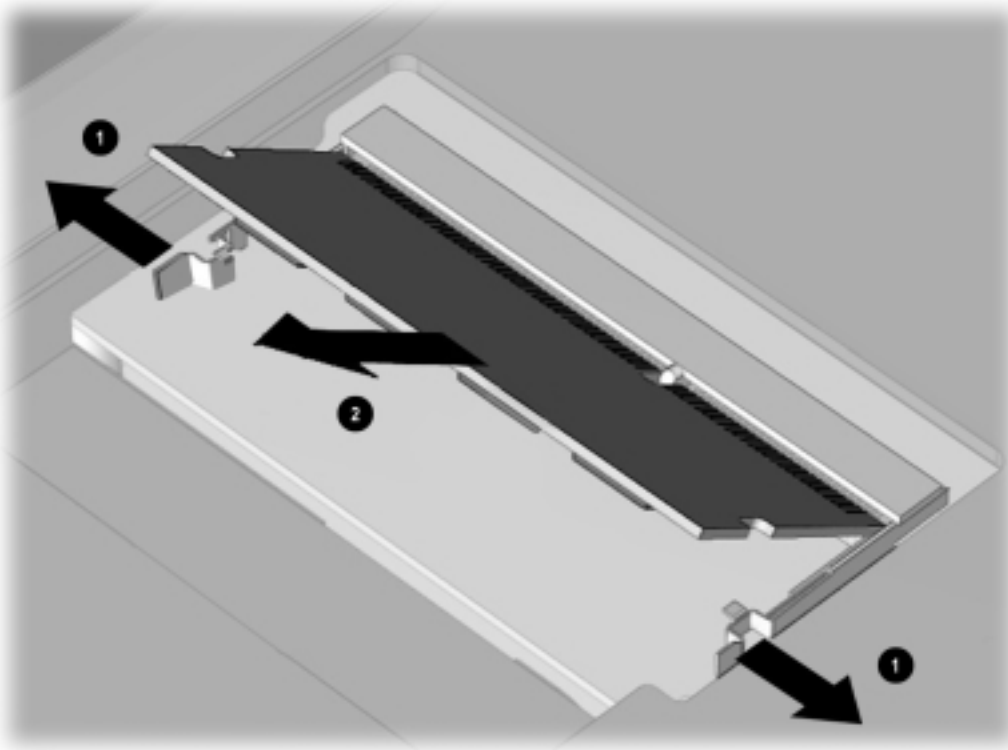

Figure 5-16. Removing the Memory Board

Installing the Memory Expansion Board

1. To add a memory board, insert the memory expansion board into the empty memory expansion slot at a 45-degree angle ❶. Then slide it gently into place until it is seated while tilted (Figure 5-17).

NOTE: All memory expansion boards supported by the computer are keyed (notched) to ensure correct positioning.

2. Push the memory expansion board down until the plastic retention clips ❷ snap into place.
3. Replace the memory insulator, if applicable.
4. Replace the keyboard by gently pressing down on the top of the keyboard until it clicks into place.

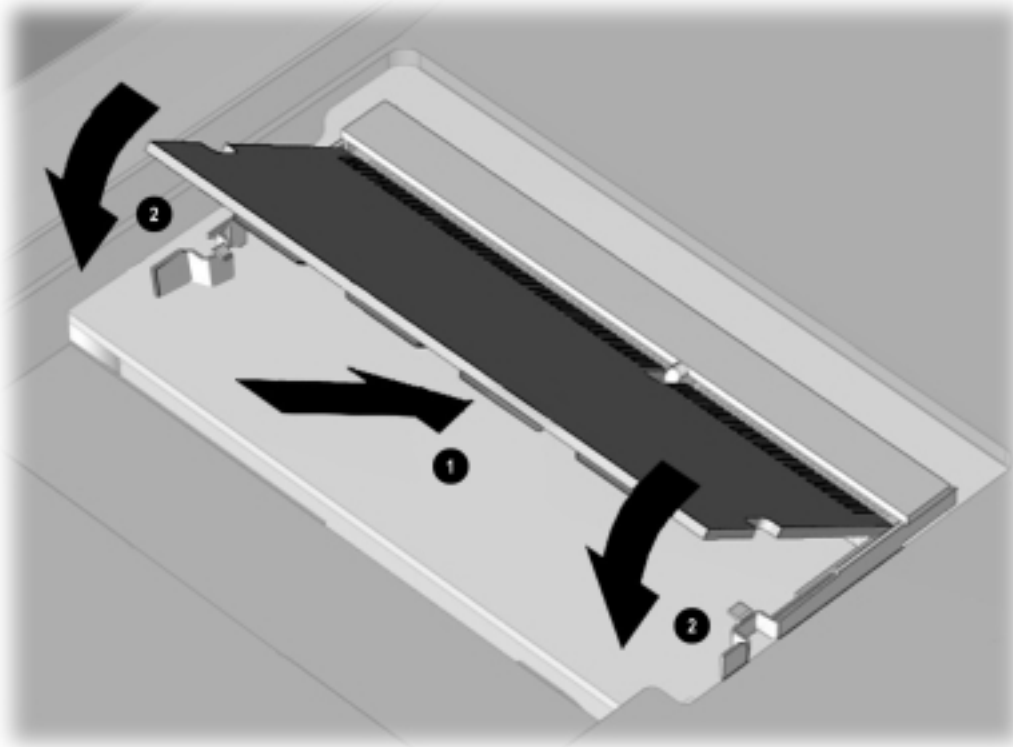

Figure 5-17. Installing the Memory Board

5.13 Switch Cover

1. Prepare the computer for disassembly (Section 5.5).
2. Remove the keyboard (Section 5.11).
3. Position the computer so the rear panel faces forward.
4. Remove the two screws from the rear panel of the computer that secure the switch cover to the base assembly (Figure 5-18).



Figure 5-18. Removing the Switch Cover Screws

5. Position the computer so the front faces forward.
6. Open the computer as far as it will open.
7. Swing the back edge of the switch cover forward ❶ (Figure 5-19).
8. When the switch cover disengages from the base assembly, remove the cover ❷.

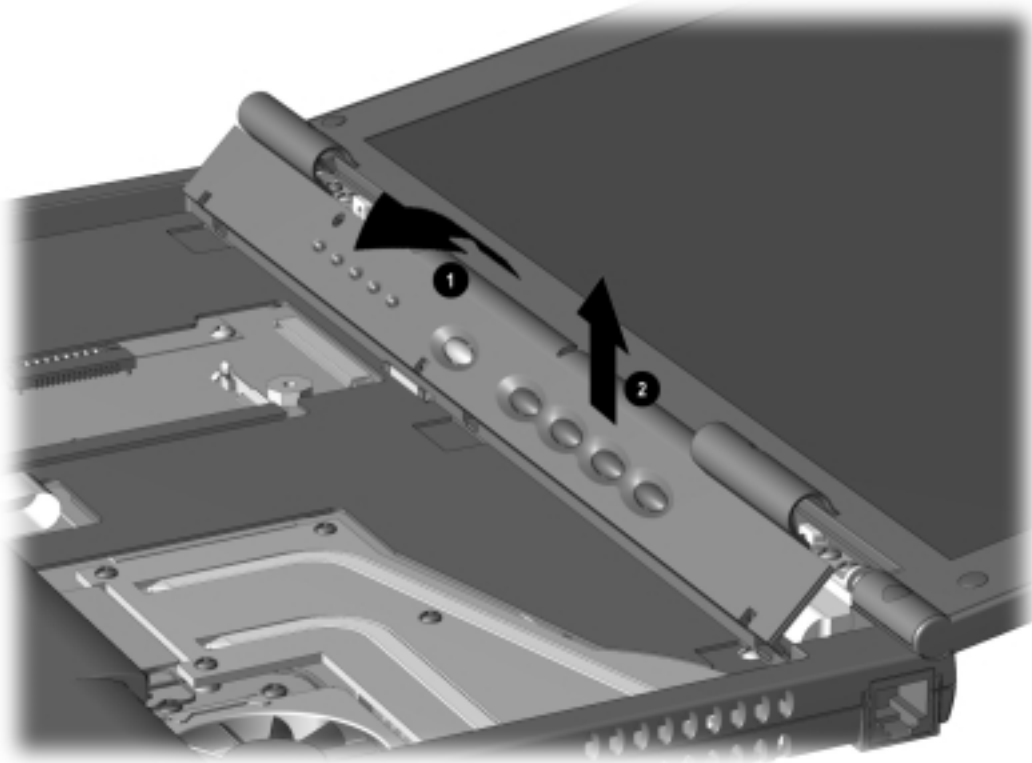

Figure 5-19. Removing the Switch Cover

Reverse the above procedure to install the switch cover.

5.14 Display Assembly

1. Prepare the computer for disassembly (Section 5.5).
2. Remove the keyboard (Section 5.11).
3. Remove the switch cover (Section 5.13).
4. Use the connector removal tool to disconnect the inverter cable ❶ from the system board (Figure 5-20).
5. Use the connector removal tool to disconnect the microphone cable ❷ and the video cable ❸ from the system board.
6. Remove display screw covers from the hinges connecting the display assembly to the base assembly.
7. Remove the four screws (two on each hinge) ❹ that secure the display assembly to the base assembly.
NOTE: When these four screws are removed, the display assembly is unsupported. Make sure to support the display assembly when removing these screws.
8. Remove the display assembly.

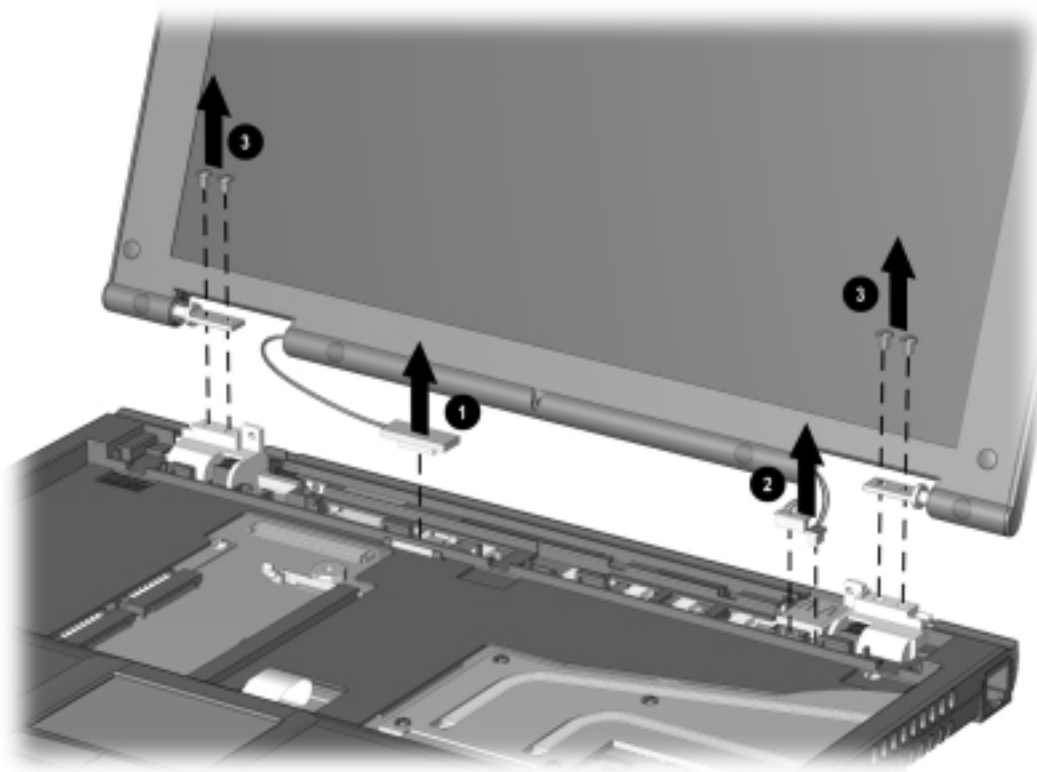

Figure 5-20. Removing the Display Assembly

Reverse the above procedure to install the display.

5.15 Top Cover with TouchPad

NOTE: The power button and infrared lens are easily dislodged when the top cover is removed. Make note of their location and orientation before removing the top cover.

1. Prepare the computer for disassembly (Figure 5.5).
2. Remove the keyboard (Section 5.11).
3. Remove the switch cover (Section 5.13).
4. Remove the display assembly (Section 5.14).
5. Turn the computer upside down with the rear panel facing forward.
6. Remove the seven screws from the bottom of the computer (Figure 5-21).
7. Remove the four screws from the back of the computer.

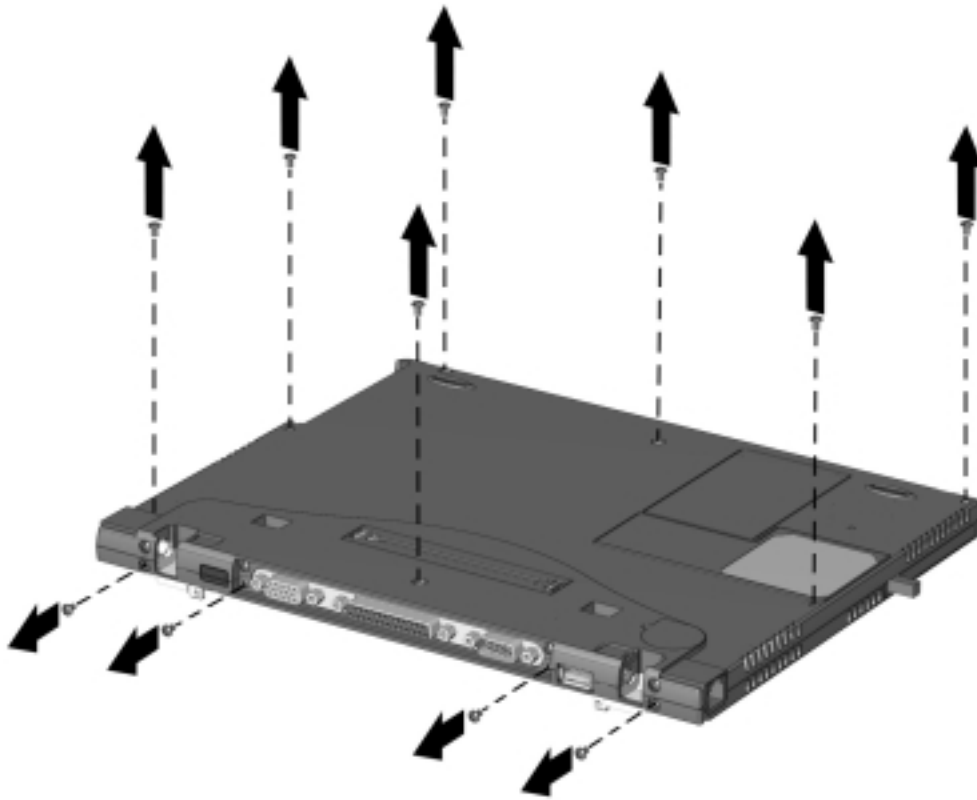

Figure 5-21. Removing the Top Cover Screws

8. Turn the computer right side up with the front facing forward.
9. Use the connector removal tool to disconnect the TouchPad cable ❶ from the system board (Figure 5-22).
10. Press in on the front of the top cover at the highlighted area ❷, and swing the front edge of the cover up and away from the base assembly ❸.
11. Remove the top cover.

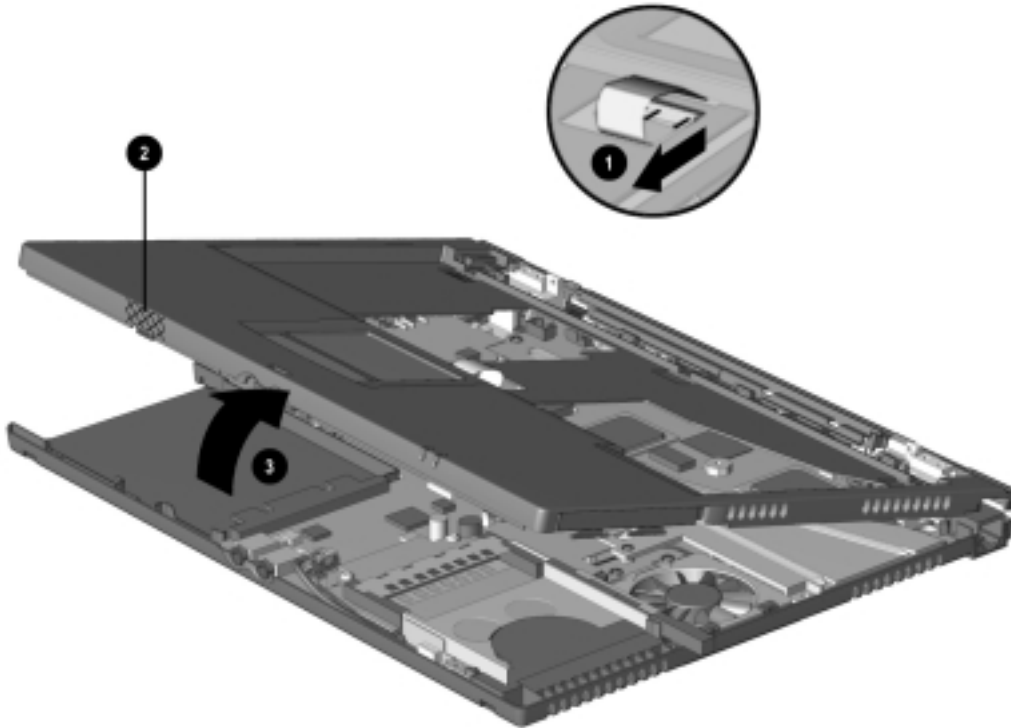

Figure 5-22. *Removing the Top Cover*

Reverse the above procedure to install the top cover. Make sure the power switch and infrared lens are replaced in their appropriate locations before attempting to install the top cover.

5.16 Voltage Converter Board

NOTE: When removing the voltage converter board from the system board, be careful of the connectors on the right side of the voltage converter board.

1. Prepare the computer for disassembly (Section 5.5).
2. Remove the keyboard (Section 5.11).
3. Remove the switch cover (Section 5.13).
4. Remove the display assembly (Section 5.14).
5. Remove the top cover (Section 5.15).
6. Remove the two screws ❶ that secure the voltage converter board to the system board (Figure 5-23).
7. Lift up the left side of the voltage converter ❷ until it clears the left edge of the base assembly.
8. Pull the voltage converter board to the left to disconnect it from the system board ❸.

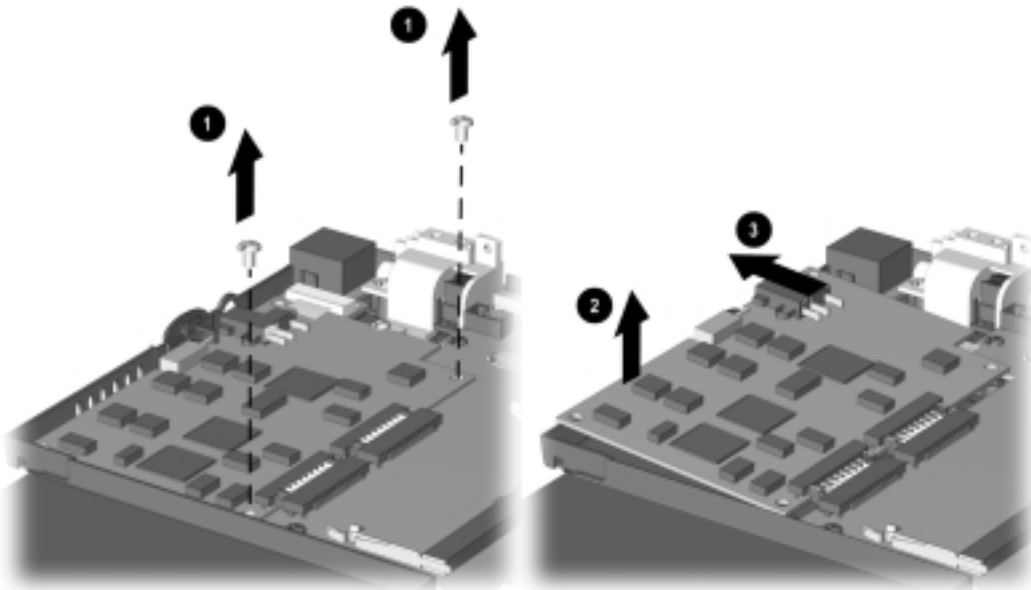

Figure 5-23. Removing the Voltage Converter Board

Reverse the above procedure to install the voltage converter board. Make sure to attach the connectors on the right side of the board to the system board first.

5.17 Modem Connector Board

1. Prepare the computer for disassembly (Section 5.5).
2. Remove the modem or modem/NIC card (Section 5.9).
3. Remove the keyboard (Section 5.11).
4. Remove the switch cover (Section 5.13).
5. Remove the display assembly (Section 5.14).
6. Remove the top cover (Section 5.15).
7. Remove the two screws that secure the modem connector board ❶ to the system board (Figure 5-24).
8. Lift up on the modem connector board ❷ to disconnect it from the system board.
9. Remove the modem connector board.

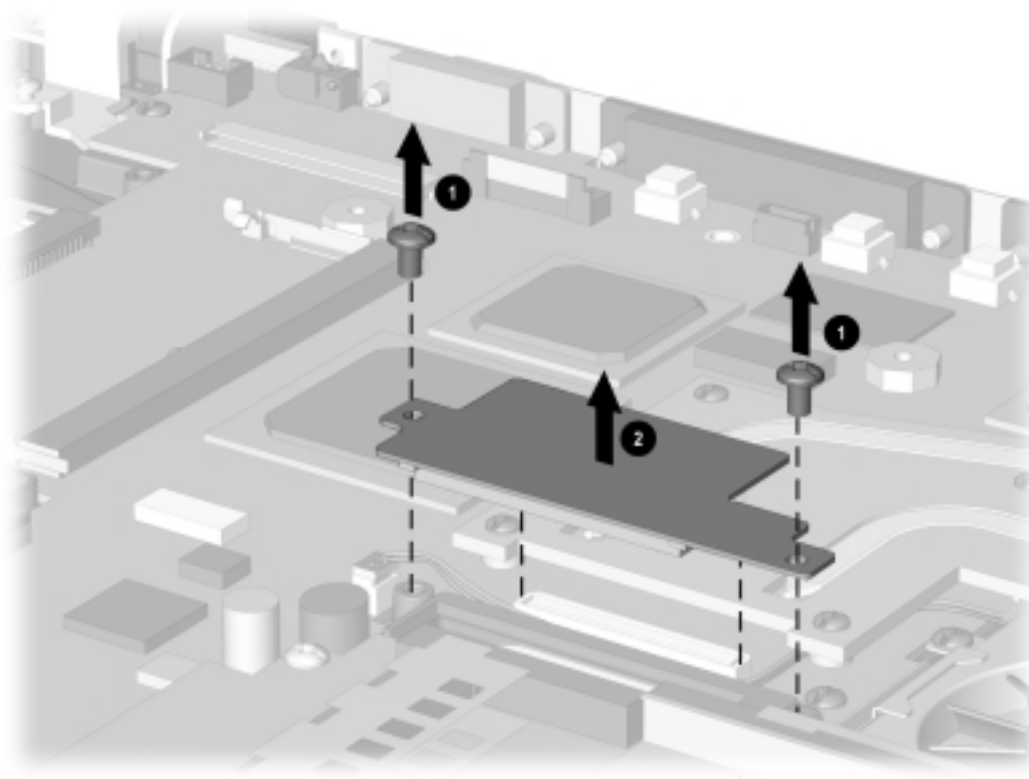

Figure 5-24. Removing the Modem Connector Board

Reverse the above procedure to install the modem connector board.

NOTE: When installing the modem connector board, make sure the fan cable is routed between the connector and the modem connector area (Figure 5-25). Do not route the cable next to the heat sink.

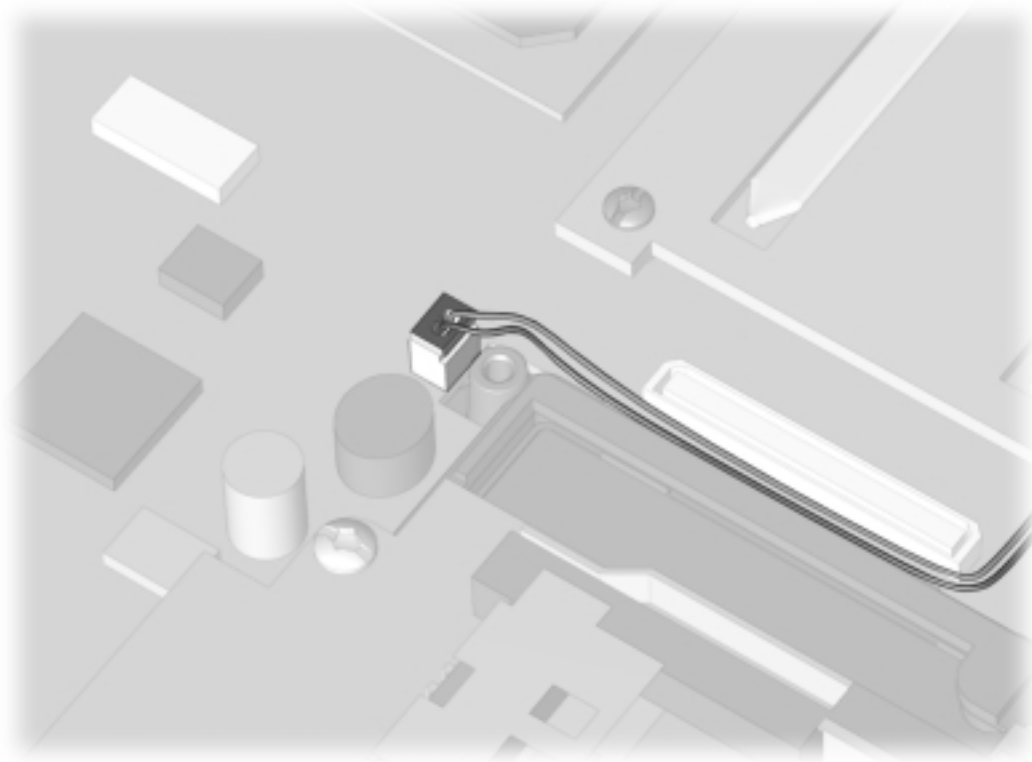

Figure 5-25. Routing the Fan Cable

5.18 PC Card Assembly

IMPORTANT: There are different-sized screws securing the PC Card assembly to the system board. Make note of the location of these screws.

1. Prepare the computer for disassembly (Section 5.5).
2. Remove the modem or modem/NIC card (Section 5.9).
3. Remove the keyboard (Section 5.11).
4. Remove the switch cover (Section 5.13).
5. Remove the display assembly (Section 5.14).
6. Remove the top cover (Section 5.15).
7. Remove the modem connector board (Section 5.17).
8. Remove the two silver screws ❶ on the left side of the PC Card assembly (Figure 5-26).
9. Remove the black screw ❷ securing the front of the PC Card assembly to the base assembly.
10. Lift the left side of the PC Card assembly ❸ to disconnect it from the system board.

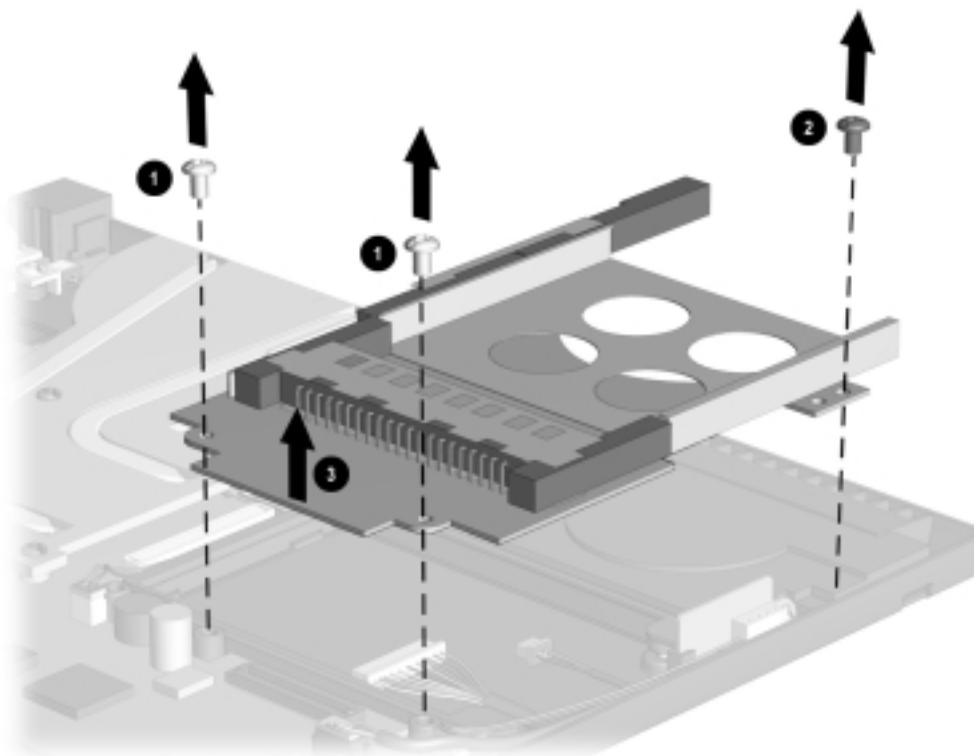

Figure 5-26. Removing the PC Card Assembly

Reverse the above procedures when installing the PC Card assembly.

IMPORTANT: Be sure to route the audio and light board cables between the PC Card assembly and the base plastic. Do not route the cables near the heat sink.

5.19 System Board

IMPORTANT: There are different-sized screws securing the system board to the base enclosure. Make note of the location of these screws. Also, when the system board is removed, components of the base enclosure may come loose. Note the location and orientation of all base enclosure components.

1. Prepare the computer for disassembly (Section 5.5).
2. Remove the RTC battery (Section 5.10).
3. Remove the keyboard (Section 5.11).
4. Remove the switch cover (Section 5.13).
5. Remove the display assembly (Section 5.14).
6. Remove the top cover (Section 5.15).
7. Remove the modem connector board (Section 5.17).
8. Remove the PC Card assembly (Section 5.18).
9. Position the computer so the front faces forward.
10. Use the connector removal tool to disconnect the left battery terminal cable **1**, right battery cable **2**, fan cable **3**, LED cable **4**, and speaker cable **5** (Figure 5-27)

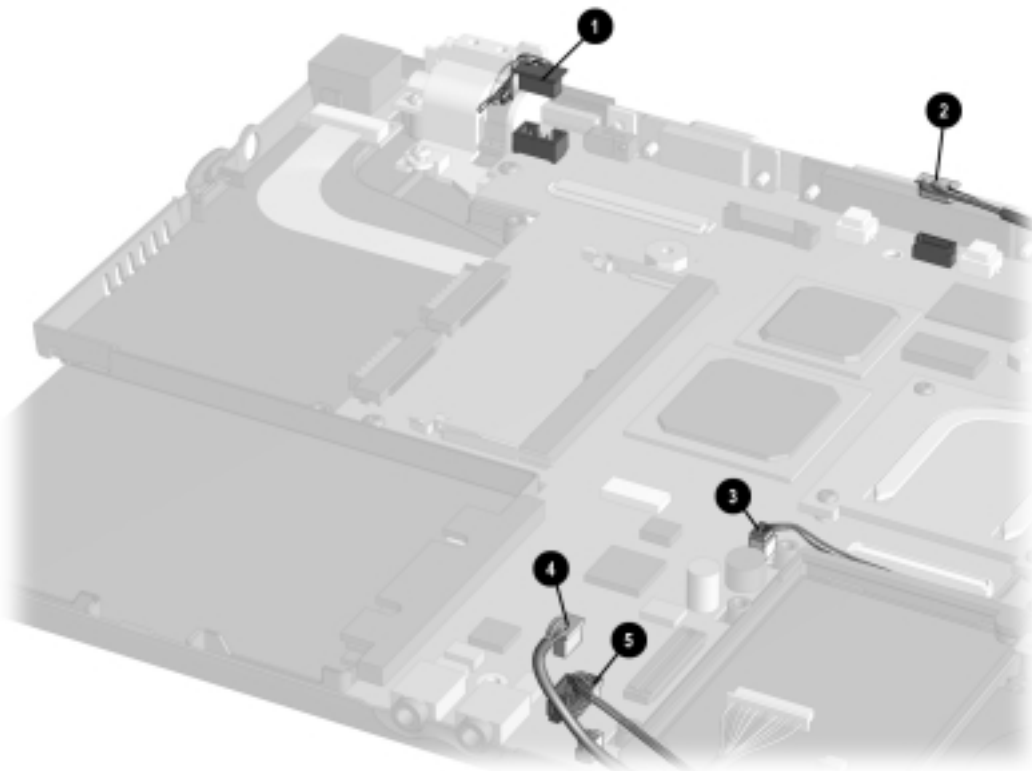

Figure 5-27. Disconnecting Cables from the System Board

11. Remove the two screws from the back of the computer that secures the system board to the base enclosure ❶ (Figure 5-28).
12. Remove the silver screw from the heat sink ❷.
13. Remove the black screws from around the fan ❸, around the USB port ❸, and around the battery cable in the upper left of the board ❸.
14. Lift up the rear edge of the system board.
15. Remove the system board.

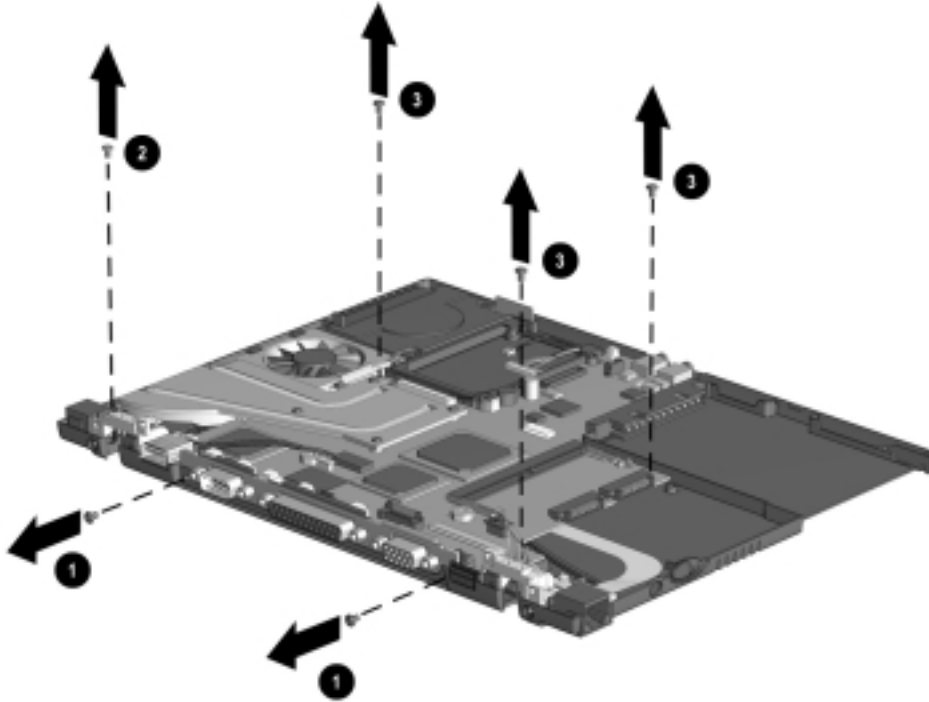

Figure 5-28. Removing the System Board

Reverse the above procedure when installing the system board. Make sure to replace all components of the base enclosure into their appropriate locations.

chapter 6

SPECIFICATIONS

6.1 Physical and Environmental

Table 6-1 Computer		
	U.S.	Metric
Dimensions		
Height	0.89 in	2.3 cm
Depth	9.0 in	22.9 cm
Width	10.4 in	26.4 cm
Weight	3.06 - 3.26 lbs	1.39 - 1.48 kg
Standalone (Battery) Power Requirements		
Nominal operating voltage (Li-Ion)	14.2 VDC	
Nominal Operating Voltage (NiMH)	9.6	
Maximum Operating Power	35 W	
Peak Operating Power	40 W	
AC Adapter		
Weight	.55 lb	.25 kg
Power Supply (Input)		
Operating Voltage	90 to 260 VAC RMS	
Operating Current	1.1 A RMS	
Operating Frequency Range	47 to 63 Hz AC	
Maximum Transient	4/50 kV	
Temperature		
Operating	41 to 95°F	5 to 35°C
Nonoperating	-22 to 140°F	-30 to 60°C
Relative Humidity (noncondensing)		
Operating	10 to 90%, non-condensing	
Nonoperating ($t_w = 38.7^\circ\text{C}$ max)	5 to 90%, 101.6°F/38.7°C maximum wet bulb temperature	
Altitude (nonpressurized environment)		
Operating	0 to 10,000 ft (14.7 to 10.1 psia)	0 to 3.05 km
Nonoperating	0 to 30,000 ft (14.7 to 4.4 psia)	0 to 9.14 km
Shock		
Operating	-10 G, 11 ms, half sine	
Nonoperating	60 G, 11 ms, half sine	
Vibration		
Operating	0.25 G, 50 to 500 Hz sine, 1/2 Oct/Min sweep rate	
Nonoperating	1 G, 50 to 500 Hz sine, 1/2 Oct/Min sweep rate	

NOTE: Applicable product safety standards specify thermal limits for plastic surfaces. The computer operates well within this range of temperatures.

6.2 Display

Table 6-2
11.3-inch Color TFT SVGA Display

	U.S.	Metric
Dimensions		
Height	7.50 in	19.00 cm
Width	10.10 in	25.60 cm
Diagonal	11.30 in	28.70 cm
Mounting	Internal	
Number of Colors	16M	
Contrast Ratio	125:1	
Brightness	120 to 150 nit AC only/80 on battery	
Pixel Resolution		
Pitch		0.264 x 0.264 mm
Format	800 x 600	
Configuration	RGB Stripe	
Backlight	CCFT	
Character Display	80 × 25	
Total Power Consumption	4.0 W	
Refresh	640 x 480, 800 x 600, 1024 x 768, 1280 x 1024, 1600 x 1200	

Table 6-3
11.3-inch Color TFT XGA Display

	U.S.	Metric
Dimensions		
Height	7.50 in	19.00 cm
Width	10.10 in	25.60 cm
Diagonal	11.30 in	28.70 cm
Mounting	Internal	
Number of Colors	16M	
Contrast Ratio	125:1	
Brightness	120 to 150 nit AC only/80 on battery	
Pixel Resolution		
Pitch		0.264 x 0.264 mm
Format	1024 x 768	
Configuration	RGB Stripe	
Backlight	CCFT	
Character Display	80 × 25	
Total Power Consumption	4.0 W	
Refresh	640 x 480, 800 x 600, 1024 x 768, 1280 x 1024, 1600 x 1200	

6.3 Hard Drive

Table 6-4 Hard Drives			
	4.3 GB	6.4 GB	12.0 GB
User capacity per drive	4.3 GB	6.4 GB	12.0 GB
Drive type	65	65	65
Drive height (with drive frame)	.5 inches / 12.5 mm	.5 inches / 12.5 mm	.5 inches / 12.5 mm
Drive width	2.75 inches / 70 mm	2.75 inches / 70 mm	2.75 inches / 70 mm
2.5-inch form factor	Yes	Yes	Yes
Sector interleave	1:1	1:1	1:1
Interface type	ATA-4	ATA-4	ATA-4
Seek times (typical, including settling)			
Single track	2.5 ms	2.5 ms	2.5 ms
Average	12.0 ms	12.0 ms	12.0 ms
Full stroke	23.0 ms	23.0 ms	23.0 ms
Physical configuration			
Cylinders	5691	9279	15880
Heads	6	6	6
Sectors per track	97 - 167	168 - 280	270 - 420
Bytes per sector	512	512	512
Logical configuration			
Cylinders	8032	13424	22415
Heads	15	15	16
Sectors per track	63	63	63
Total customer usable data sectors	8,484,385	12,685,680	23,677,353
Bytes per sector	512	512	512
Buffer size	512 K	512 K	512 K
Disk rotational speed (rpm)	4200	4200	4200
Transfer rate			
synchronous (maximum)	33.3 MB/second	33.3 MB/second	33.3 MB/second

6.4 Diskette Drive

**Table 6-6
Diskette Drive**

Diskette Size	3.5 in (8.87 cm)
Light	On drive
Height	0.55 in (1.40 cm)
Bytes per Sector	512
Sectors per Track	
High Density	18 (1.44 MB)/15 (1.2 MB)
Low Density	9
Tracks per Side	
High Density	80 (1.44 MB)/80 (1.2 MB)
Low Density	80
Read/Write Heads	2
Access Times	
Track-to-Track (high/low)	3 ms/6 ms
Average (high/low)	94 ms/174 ms
Settling Time	15 ms
Latency Average	100 ms

6.5 Li-Ion Battery Pack

**Table 6-7
Computer Battery Pack**

	U.S.	Metric
Height	0.9 in	2.3 cm
Width	10.47 in	26.6 cm
Weight	0.48 lb	0.21 kg
Cells	4 Li-Ion	
Energy		
Voltage	14.4 V	
Amp-hour capacity	2.8 Ah	
Watt-hour capacity	27Wh	
Temperature		
Operating	41° to 95° F	5° to 35° C
Nonoperating	- 22° to 140° F	- 30° to 60° C

6.6 CD-ROM Drive

**Table 6-8
CD-ROM Drive**

Applicable Disc	CD-ROM (Mode 1, 2, and 3) CD-XA ready (Mode 2, Form 1 and 2) CD-I ready (Mode 2, Form 1 and Form 2) CD-R (read only) CD Plus Photo CD (single/multisession) CD Extra Video CD CD-WO (fixed packets only) CD-Bridge
Center Hole Diameter	.59 in./15 mm
Disc Diameter	12 cm, 8 cm
Disc Thickness	1.2 mm
Track Pitch	1.6 μ m
Laser	
Beam Divergence	53.5 \pm 1.5 degrees
Output Power	0.24 \pm 0.1 mw
Type	Semiconductor Laser GaAlAs
Wave Length	780 nm \pm 25 nm
Access Time	
Random	< 150 ms
Full Stroke	< 300 ms
Audio Output Level	
Line Out	0.7 V rms
Headphone	none
Cache Buffer	128 KB
Data Transfer Rate	
Sustained, 24X	150 KB/sec
Variable	1500 to 3600 KB/sec
Normal PIO Mode 4 (single burst)	16.6 MB/sec
Startup time	< 8.3 seconds
Stop time	< 4.0 seconds
Capacity	
Mode 1, 12 cm	550 MB
Mode 2, 12 cm	640 MB
8 cm	180 MB

6.7 DVD-ROM Drive

Table 6-9
DVD-ROM Specifications

Applicable Disc	DVD-5, DVD-9, DVD-10 CD-ROM mode 1, mode 2 CD-Digital Audio CD-XA mode 2 (Form 1, Form 2) CD-I mode 2 (Form 1 and Form 2) CD-I Ready CD-Bridge CD-R Photo CD (single/multisession)
Center Hole Diameter	.59 in./15 mm
Disc Diameter	12 cm, 8 cm
Disc Thickness	1.2 mm
Track Pitch	.74 μ m
Capacity	
DVD-5	4.7 GB
DVD-9	8.5 GB
DVD-10	9.4 GB
Mode 1, 12	550 MB
Mode 2, 12 cm	640 MB
8 cm	180 MB
Laser	
Output Power	5 mw
Type	Semiconductor Laser GaAlAs
Wave Length	650 nm \pm 25nm (DVD-ROM mode) 795 nm \pm 25 nm (CD-ROM mode)
Access Time	
Random	< 150 ms
Full Stroke	< 225 ms
Audio Output Level	
Line Out	0.7 V rms
Headphone	none
Cache Buffer	128 KB
Data Transfer Rate	
Sustained, 16x	150 KB/sec
Sustained, 4x DVD	5520 KB/sec
Normal PIO Mode 4 (single burst)	16.6 MB/sec
Startup Time	< 15 seconds
Stop time	< 6 seconds

6.8 System Interrupts

Table 6-10
System Interrupts

Hardware IRQ	System Function
IRQ1	Timer Interrupt
IRQ2	Cascaded
IRQ3	PCMCIA
IRQ4	COM1
IRQ5	Audio (default)*
IRQ6	Diskette drive
IRQ7	Parallel
IRQ8	RTC
IRQ9	Infrared
IRQ10	PCMCIA
IRQ12	Internal Point Stick or External Mouse
IRQ13	Coprocessor (Not available to any peripheral)
IRQ14	IDE Interface (Hard Disk)

Notes:

PCMCIA cards may assert IRQ3, IRQ4, IRQ5, IRQ7, IRQ9, IRQ10, IRQ11, or IRQ15.
Either the infrared or the serial port may assert IRQ3 or IRQ4.

*Default configuration; audio possible configurations are: IRQ5, IRQ7, IRQ9, IRQ10, or none.

6.9 System DMA

Table 6-11
System DMA

Hardware DMA	System Function
DMA0	Available for audio
DMA1	Entertainment Audio (Default; Alternate = DMA0, DMA3, None)
DMA2	Diskette Drive
DMA3	ECP Parallel Port LPT1 (Default; Alternate = DMA0, None)
DMA4	DMA Controller Cascading (Not available)
DMA5	Available for PC Card
DMA6	Not Assigned
DMA7	Not Assigned

Note: PC Card controller can use DMA 1, 2, or 5.

6.10 System I/O Addresses

Table 6-12
System I/O Addresses

I/O Address (Hex)	System Function (Shipping Configuration)
000 - 00F	DMA Controller no. 1
010 - 01F	Unused
020 - 021	Interrupt Controller no. 1
022 - 024	Opti Chipset Configuration registers
025 - 03F	Unused
02E - 02F	87334 "Super IO" configuration for CPU
040 - 043	Counter/Timer Registers
044 - 05F	Unused
060	Keyboard Controller
061	Port B
062 - 063	Unused
064	Keyboard Controller
065 - 06F	Unused
070 - 071	NMI Enable/Real Time Clock
072 - 07F	Unused
080 - 08F	DMA Page Registers
090 - 091	Unused
092	Port A
093 - 09F	Unused
0A0 - 0A1	Interrupt Controller no. 2
0A2 - 0BF	Unused
0C0 - 0DF	DMA Controller no. 2
0E0 - 0EF	Unused
0F0 - 0F1	Coprocessor Busy Clear/Reset
0F2 - 0FF	Unused
100 - 16F	Unused
170 - 177	Secondary Fixed Disk Controller
178 - 1EF	Unused
1F0 - 1F7	Primary Fixed Disk Controller
1F8 - 200	Unused
201	Joystick (Decoded in ESS1688)
202 - 21F	Unused
220 - 22F	Entertainment Audio
230 - 26D	Unused
278 - 27F	Unused
280 - 2AB	Unused
2A8 - 2E7	Unused

Continued

Table 6-12 *Continued*

I/O Address (Hex)	System Function (Shipping Configuration)
2E8 - 2EF	Reserved Serial Port
2F0 - 2F7	Unused
2F8 - 2FF	Infrared port
320 - 36F	Unused
378 - 37F	Parallel Port (LPT1/Default)
380 - 387	Unused
388 - 38B	FM Synthesizer - OPL3
38C - 3AF	Unused
3B0 - 3BB	VGA
3BC - 3BF	Reserved (Parallel Port/No EPP Support)
3C0 - 3DF	VGA
3E0 - 3E1	PC Card Controller in CPU
3E8 - 3EF	SMC IrCC (Fast Infrared) Hardware and Driver (Com 3)
3F0 - 3F7	"A" Diskette Controller
3F8 - 3FF	Serial Port (COM1/Default)
CF8 - CFB	PCI Configuration Index Register (PCIDIV0-1)
CFC - CFF	PCI Configuration Data Register (PCIDIV0-1)

6.11 System Memory Map

Table 6-13
System Memory Map

Size	Memory Address	System Function
640 K	00000000 - 0009FFFF	Base Memory
128 K	000A0000 - 000BFFFF	Video Memory
48 K	000C0000 - 000CBFFF	Video BIOS
160 K	000C8000 - 000E7FFF	Unused
64 K	000E8000 - 000FFFFF	System BIOS
15 M	00100000 - 00FFFFFF	Extended Memory
58 M	01000000 - 047FFFFF	Super Extended Memory
58 M	04800000 - 07FFFFFF	Unused
2 M	08000000 - 080FFFFF	Video Memory (Direct Access)
4 G	08200000 - FFFFFFFFFF	Unused
64 K	FFFF0000 - FFFFFFFF	System BIOS

Index

A

- AC
 - Adapter
 - specifications, 6-1
 - power cord
 - spare part number, 3-6
- air exhaust vents
 - illustrated, 1-11
- air intake vents
 - illustrated, 1-11
- altitude specifications, 6-1
- Asset Management, 1-4
- asset tag number, 1-4

B

- battery
 - latches
 - illustrated, 1-14
 - light
 - illustrated, 1-9, 1-12
 - pack, 5-6
 - illustrated, 1-13, 3-2
 - removing, 5-6
 - replacing, 5-7
 - requirements, 6-1
 - spare part number, 3-3
 - specifications, 6-4
 - charger
 - spare part number, 3-6
- beep codes, 2-6
- boot options, 2-9
- brightness
 - display, 6-2

C

- cables
 - handling, 1-2
- caps lock light
 - illustrated, 1-8
- caution
 - electrostatic discharge, 5-18
 - PC Card, inserting, 5-12
 - PC Card, removing, 5-11

- CD-ROM drive
 - specifications, 6-4, 6-5
- character display, 6-2
- combo modem
 - spare part number, 3-6
- Compaq
 - utilities, 2-6
- computer
 - components
 - bottom, 1-14
 - front, 1-12
 - illustrated, 3-2
 - left side, 1-10
 - rear, 1-13
 - right side, 1-11
 - top, 1-8
 - disassembly reference chart,
 - 5-2
 - disconnecting, 5-4
 - disconnecting from the
 - mobile expansion unit, 5-3
 - features, 1-1, 1-4
 - models, 1-2
 - preparing for disassembly,
 - 5-5
 - serial number, 1-1
 - weight, 6-1
 - dimensions, 6-1
- Computer Setup, 2-7
- Configuration Management,
 - 1-7
- configuration utilities, 2-7
- connector doors (upper and lower)
 - illustrated, 3-4
- connectors
 - handling, 1-2
- contrast ratio
 - display, 6-2
- control door spring (left and right)
 - illustrated, 3-4
- CPU base enclosure
 - illustrated, 3-2
 - spare part number, 3-3

D

- default settings, 2-10
 - initialization, 2-10
 - ports, 2-11
 - power, 2-11
 - security, 2-11
- design overview, 1-15
- device
 - options, 2-9
 - security, 2-8
- diagnostics, 2-7
- dimensions
 - computer, 6-1
- disassembly reference chart,
 - 5-2
- disconnecting computer, 5-4
- disconnecting the computer
 - from the mobile expansion unit, 5-3
- diskette
 - drive
 - specifications, 6-3
 - drive light
 - illustrated, 1-8
- display
 - assembly
 - dimensions, 6-2
 - illustrated, 3-2
 - installing, 5-22
 - power consumption, 6-2
 - removing, 5-22
 - spare part number, 3-3
 - specifications, 6-2
 - release latch
 - illustrated, 1-12
 - switch
 - illustrated, 1-8
- docking
 - connector
 - illustrated, 1-14
 - pinout, A-3
- DVD-ROM drive
 - specifications, 6-5

E

- electrostatic
 - damage
 - preventing, 1-3
 - discharge
 - typical voltage levels, 1-6
- energy saving, 1-7
- environmental
 - specifications, 1-1
- external diskette drive
 - illustrated, 3-5
 - spare part number, 3-5
- external diskette drive cable
 - illustrated, 3-5
 - spare part number, 3-5
- external monitor
 - connector
 - illustrated, 1-13

F

- fan
 - illustrated, 1-14
- fatal error
 - beep codes, 2-6
 - messages, 2-5
- Fault Management, 1-5
 - alerts, 1-6
- features, 1-1, 1-2
 - computer, 1-2

G

- grounding
 - methods, 1-5

H

- hard drive, 5-8
 - bay
 - illustrated, 1-10
 - bezel
 - illustrated, 1-14
 - illustrated, 3-2, 3-5
 - inserting, 5-9
 - light
 - illustrated, 1-8
 - removing, 5-8
 - security screw
 - illustrated, 1-14
 - spare part number, 3-3, 3-5
 - specifications, 6-3

- hardware
 - updating, 2-12
- headphone
 - jack
 - illustrated, 1-12
 - pinout, A-2
- hinge rubber cap
 - illustrated, 3-4
- humidity specifications, 6-1

I

- I/O addresses, 6-7
- Info Messenger, 2-12
- infrared
 - port
 - illustrated, 1-13
- initialization
 - default settings, 2-10
- Intelligent Manageability, 1-4
 - Asset Management, 1-4
 - Configuration Management, 1-7
 - Fault Management, 1-5
 - alerts, 1-6
 - Security Management, 1-6
 - Web Agent, 1-4
- internal microphone
 - illustrated, 1-8
- inventory information, 1-5
- IR lens
 - illustrated, 3-4

K

- keyboard
 - connector
 - pinout, A-5
 - illustrated, 3-2
 - installing, 5-17
 - removing, 5-16
 - spare part number, 3-3

M

- maintenance
 - updating system, 2-12
- Maintenance & Service Guide*
 - spare part number, 3-6
- mass storage devices
 - illustrated, 3-5

- memory
 - expansion, 5-18
 - board
 - illustrated, 3-2
 - installing, 5-19
 - removing, 5-18
 - spare part number, 3-3, 3-6
 - map, 6-9
- messages
 - fatal error, 2-5
 - warning, 2-4
- microphone
 - jack
 - illustrated, 1-12
 - pinout, A-1
- Microsoft logo key
 - illustrated, 1-9
- mini PCI dummy card
 - illustrated, 3-4
- Miscellaneous Plastic Kit
 - components
 - illustrated, 3-4
 - contents, 3-3, 3-4
 - spare part number, 3-3, 3-4
- Miscellaneous Screw Kit
 - spare part number, 3-6
- miscellaneous spare part numbers, 3-6
- mobile expansion unit
 - features, 1-2
 - spare part number, 3-6
- model table, 1-3
- models
 - computer, 1-3
- modem
 - compartment
 - illustrated, 1-14
 - connector board
 - illustrated, 3-2
 - installing, 5-27
 - removing, 5-26
 - spare part number, 3-3
 - cover
 - illustrated, 3-2, 3-4
 - illustrated, 3-2
 - PC Card
 - spare part number, 3-6
 - modem/combo card
 - installing, 5-14, 5-26
 - removing, 5-13

- monitor
 - connector
 - pinout, A-6
- mouse
 - connector
 - pinout, A-5

N

- num lock light
 - illustrated, 1-8

O

- operating system (installed),
 - 1-2

P

- packaging
 - precautions, 1-3
- parallel
 - connector
 - illustrated, 1-13
 - pinout, A-2
- password
 - clearing, 2-3
- PC Card, 5-10
 - assembly
 - illustrated, 3-2
 - installing, 5-28
 - removing, 5-28
 - spare part number, 3-3
 - door, 5-12
 - illustrated, 3-4
 - spring
 - illustrated, 3-4
 - eject button, 5-11
 - guide rails, 5-12
 - inserting, 5-12
 - removing, 5-11
 - slot
 - illustrated, 1-11
 - stopping, 5-11
- physical
 - specifications, 1-1
- pick button
 - left
 - illustrated, 1-9
 - right
 - illustrated, 1-9
- pixel resolution
 - display, 6-2

- plastic parts
 - handling, 1-1
- ports
 - default settings, 2-11
- POST
 - (Power-On Self-Test), 2-3
 - error messages, 2-4
- power
 - button
 - illustrated, 1-10
 - connector
 - illustrated, 1-10
 - consumption
 - display, 6-2
 - cord set
 - country-specific
 - requirements, B-2
 - general requirements, B-1
 - requirements, 1-1, B-1
 - default settings, 2-11
 - knob
 - illustrated, 3-4
 - management, 1-7
 - management levels, 1-7
- power/suspend light
 - illustrated, 1-9, 1-12
- Power-On Self-Test (POST),
 - 2-3
- preparing for disassembly, 5-5
- processor board
 - illustrated, 3-2
 - spare part number, 3-3

Q

- QuickBoot, 2-9

R

- real time clock battery
 - cover
 - illustrated, 3-4
 - illustrated, 1-14, 3-2, 3-4
 - installing, 5-15
 - removing, 5-15
- refresh
 - display, 6-2
- return kit
 - spare part number, 3-6
- RJ-11
 - jack
 - illustrated, 1-11
 - pinout, A-1

- RJ-45
 - jack
 - illustrated, 1-10
- RTC battery
 - cover
 - illustrated, 3-4
 - illustrated, 1-14, 3-4
- rubber feet
 - illustrated, 3-4

S

- saving energy, 1-7
- scroll lock light
 - illustrated, 1-8
- security
 - cable slot
 - illustrated, 1-10
 - default settings, 2-11
- Security Management, 1-6
- serial
 - connector
 - illustrated, 1-13
 - pinout, A-1
 - number, viii
 - illustrated, 1-14
 - location, 3-1, 1-1
- service considerations, 1-1
- setup
 - computer, 2-7
- shock specifications, 6-1
- software
 - Info Messenger, 2-12
 - updating, 2-12
- spare part numbers
 - major components, 3-3
 - mass storage devices, 3-5
 - miscellaneous, 3-6
- speaker
 - illustrated, 1-14
- specifications, 1-1
 - battery pack, 6-4
 - CD-ROM drive, 6-4, 6-5
 - diskette drive, 6-3
 - display, 6-2
 - DMA, 6-7
 - DVD-ROM drive, 6-5
 - environmental, 1-1
 - hard drive, 6-3
 - I/O addresses, 6-7
 - interrupts, 6-6
 - memory map, 6-9
 - physical, 1-1

- stereo
 - line-in
 - jack
 - pinout, A-2
 - speaker
 - jack
 - illustrated, 1-12
 - pinout, A-2
- Suspend button
 - illustrated, 1-8
- switch cover
 - illustrated, 3-2, 3-4
 - installing, 5-21
 - removing, 5-20
- system
 - board, 1-15
 - installing, 5-30
 - removing, 5-29
 - DMA, 6-7
 - I/O address, 6-7
 - IDs, 2-8
 - interrupts, 6-6
 - memory map, 6-9
 - ROM updates, 2-12

T

- technician notes, vii
- temperature specifications, 6-1
- tool
 - required for service, 1-1
- top cover
 - installing, 5-24
 - removing, 5-23
- Touchpad
 - illustrated, 1-9
 - spare part number, 3-3
- transporting
 - precautions, 1-3
- troubleshooting, 1-1
 - checklist, 2-13
 - preliminary steps, 2-2
 - without diagnostics, 2-12

U

- universal serial bus
 - connector
 - illustrated, 1-13
- USB
 - connector
 - illustrated, 1-13
- utilities, Compaq, 2-6

V

- vents
 - illustrated, 1-10
- vibration specifications, 6-1
- video memory, 1-2
- voltage converter board
 - illustrated, 3-2
 - installing, 5-25
 - removing, 5-25
 - spare part number, 3-3

W

- warning messages, 2-4
- Web Agent, 1-4
- weight
 - computer, 6-1
- Windows
 - application key
 - illustrated, 1-8
- workstation
 - precautions, 1-4