

DEWALT®

DW077

Dansk	11
-------	----

Deutsch	21
---------	----

English	33
---------	----

Français	43
----------	----

Norsk	54
-------	----

Suomi	64
-------	----

Svenska	74
---------	----

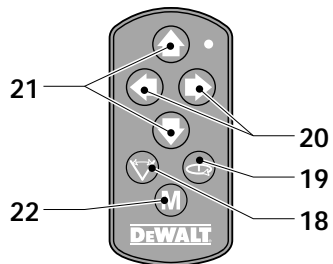
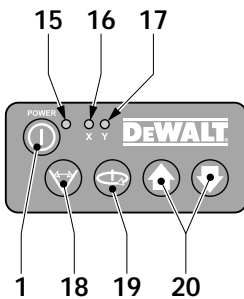
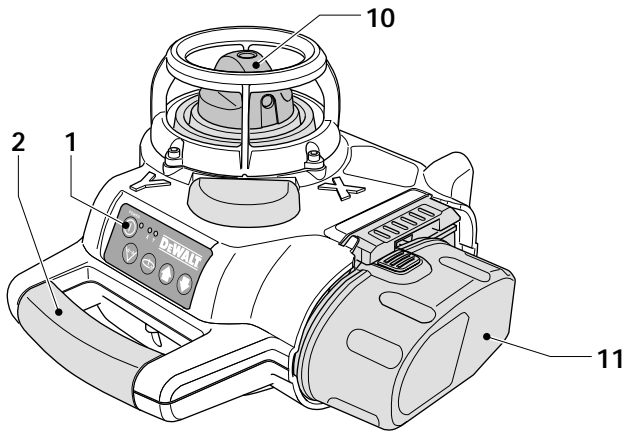
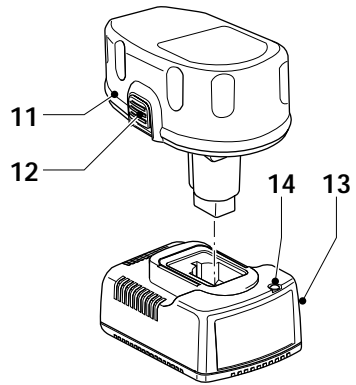
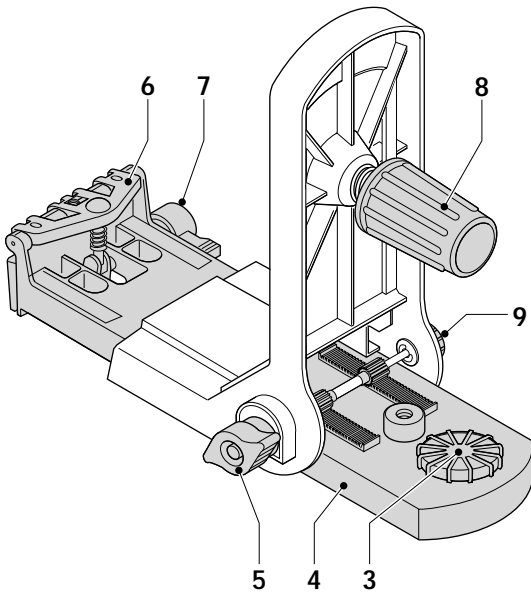

A

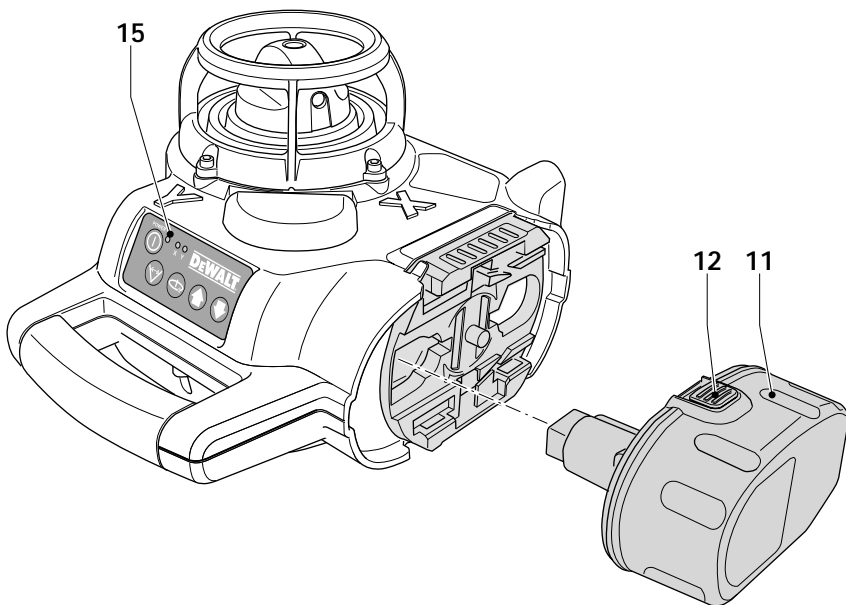

B1

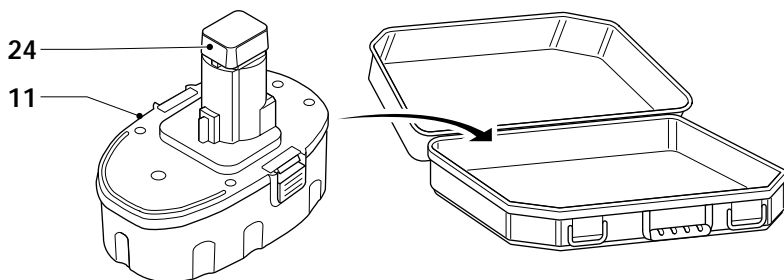
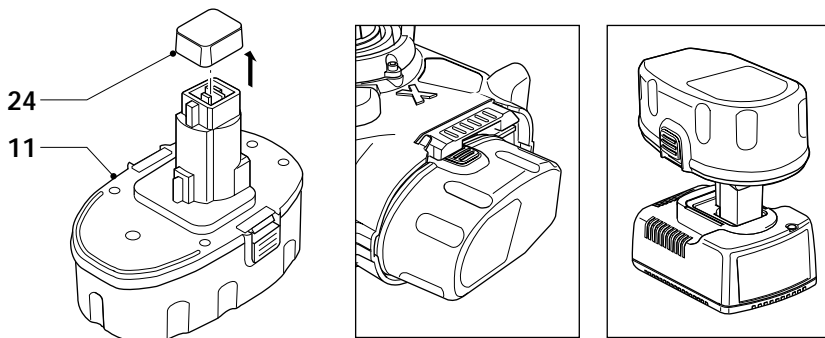

B2

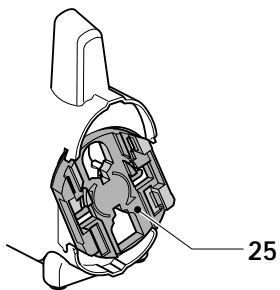

B3

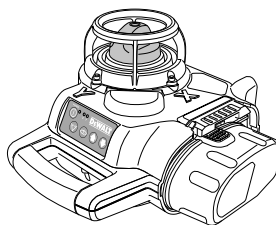
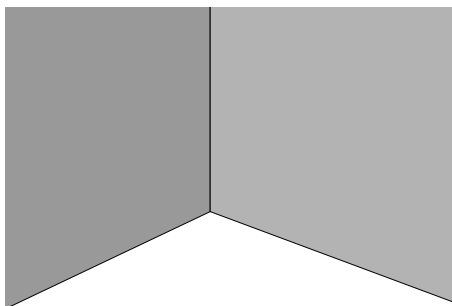

C1

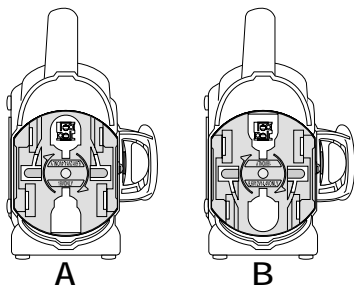

B4

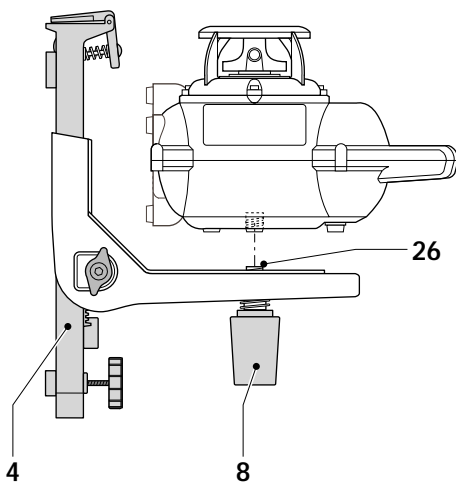
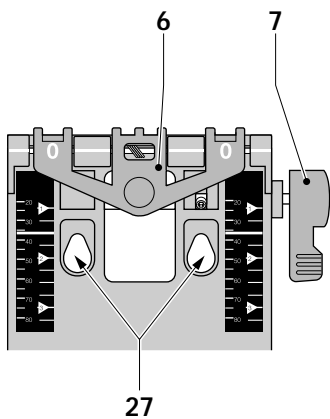

C2

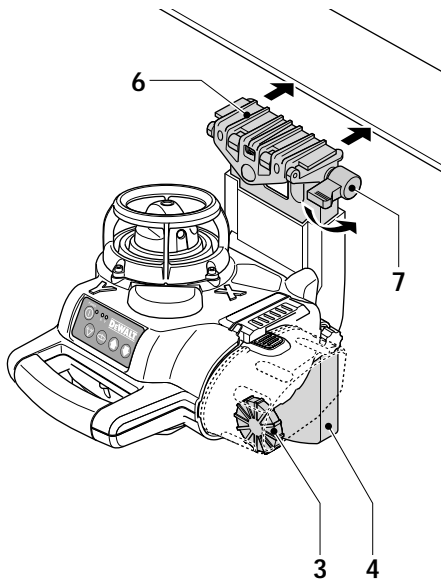

C3

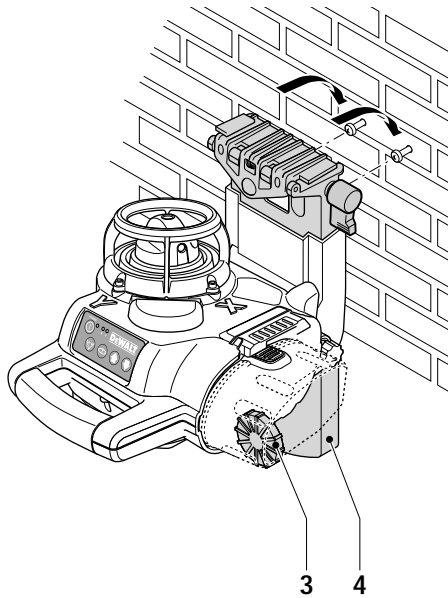

C4

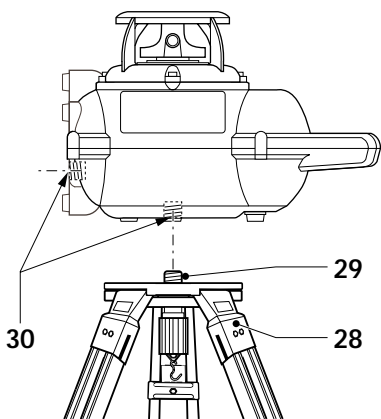

C5

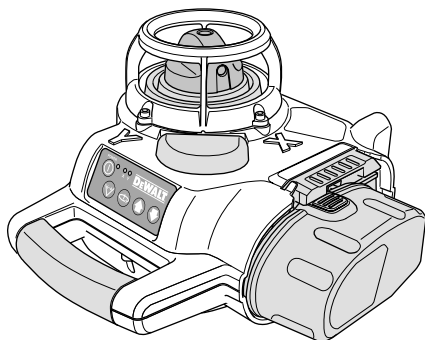

D1

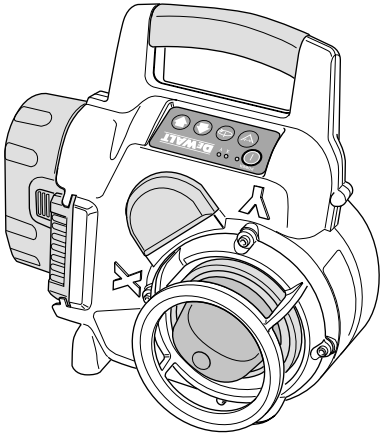

D2

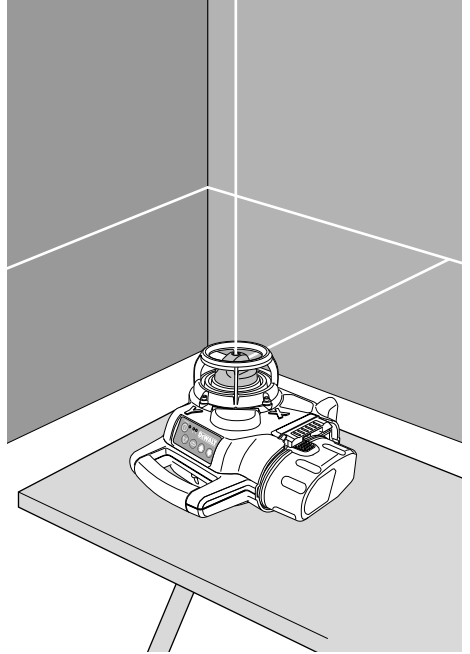

E1

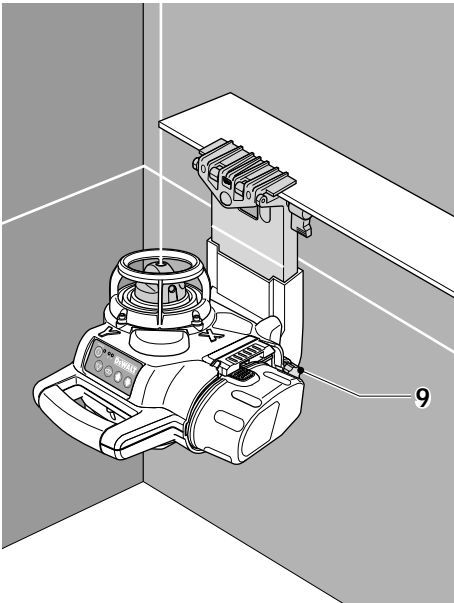

E2

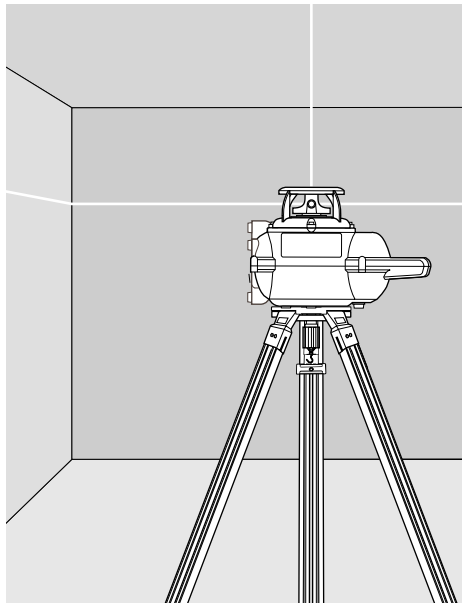

E3

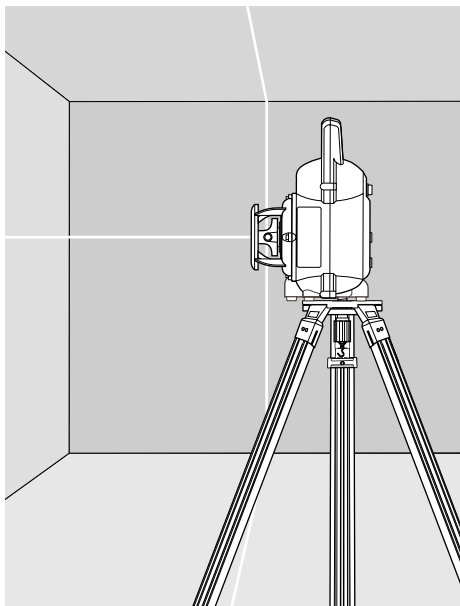

E4

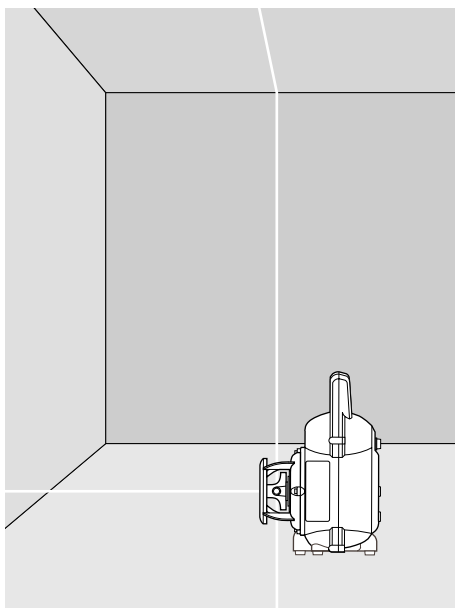

E5

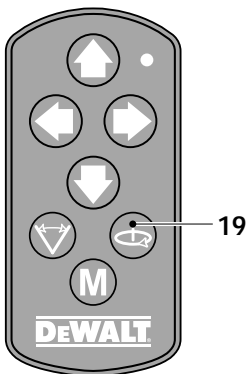

F

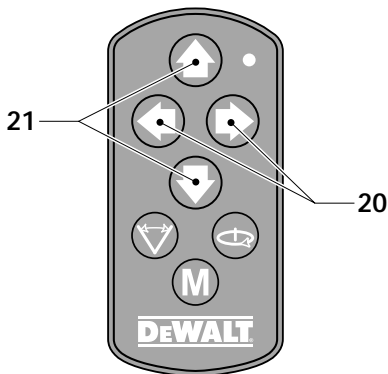

G1

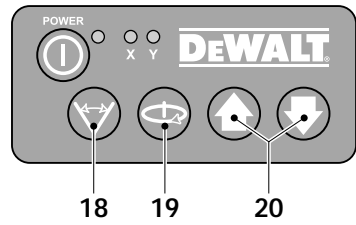
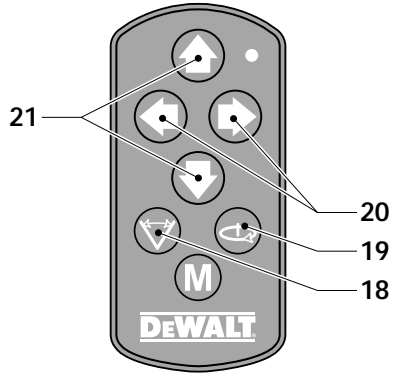
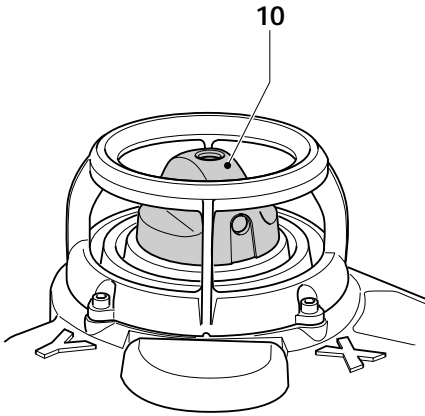

G2

H

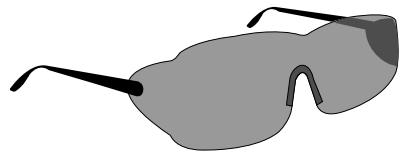
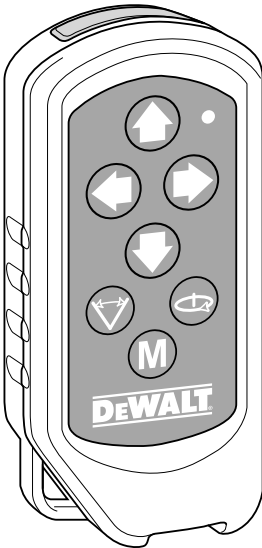

I1

I2

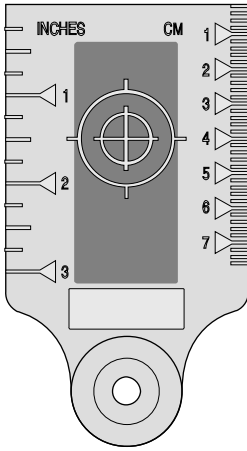

13

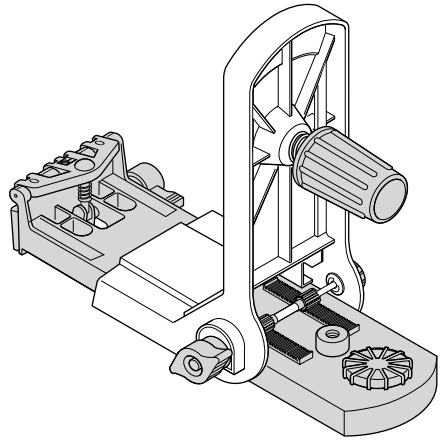

14

ROTARY LASER DW077

Congratulations!

You have chosen a DeWALT tool. Years of experience, thorough product development and innovation make DeWALT one of the most reliable partners for professional power tool users.

Technical data

		DW077	
Voltage	V	9.6/12/14.4/18	
Rotary speed	min ⁻¹	0/10/80/280/800	
Laser class		II	
Protection class		IP54	
Self-leveling range	°	+/- 5	
Operating temperature	°C	-5 - +45	
Receptacle thread		5/8" x 11	
Weight (without battery pack)	kg	2.5	

		DE9095	DE9039
Battery pack		DE9095	DE9039
Battery type		NiCd	NiMH
Voltage	V	18	18
Weight	kg	1.1	1.1
Charger		DE9108	DE9116
Mains voltage	V _{AC}	230	230
Approx. charging time	min	60	60
Weight	kg	0.4	0.4

Europe	230 V tools	10 Amperes, mains
U.K. & Ireland	230 V tools	13 Amperes, in plugs

The following symbols are used throughout this manual:



Denotes risk of personal injury, loss of life or damage to the tool in case of non-observance of the instructions in this manual.



Denotes risk of electric shock.



Fire hazard.

EC-Declaration of conformity



DW077

DeWALT declares that these tools have been designed in compliance with: 73/23/EEC, 98/37/EEC, 89/336/EEC, EN 60335, EN 55014-1, EN 55014-2, EN 61000-3-2, EN 61000-3-3, EN 60825-1 & EN 61010-1.

For more information, please contact DeWALT at the address below or refer to the back of the manual.

		DW077
L _{pa} (sound pressure)	dB(A)*	< 70
Weighted RMS acceleration value	m/s ²	< 2.5

* at the operator's ear

TÜV Rheinland
Product and Safety GmbH (TRPS)
Am Grauen Stein 1
D-51105 Köln
Germany

Cert. No.	21103197 001
-----------	--------------

Director Engineering and Product Development
Horst Großmann

DeWALT, Richard-Klinger-Straße 40,
D-65510, Idstein, Germany

Safety instructions

When using power tools, always observe the safety regulations applicable in your country to reduce the risk of fire, electric shock and personal injury.

Read all of this manual carefully before operating the tool. Also refer to the manual of any power tool that will be used with this tool.

Save this manual for future reference.

General

1 Keep work area clean

Cluttered areas and benches can cause accidents.

2 Consider work area environment

Do not expose power tools to humidity. Keep work area well lit. Do not use power tools in the presence of flammable liquids or gases.

3 Guard against electric shock

Prevent body contact with earthed surfaces (e.g. pipes, radiators, cookers and refrigerators).

For use under extreme conditions (e.g. high humidity, when metal swarf is being produced, etc.) electric safety can be improved by inserting an isolating transformer or a (FI) earth-leakage circuit-breaker.

4 Keep children away

Do not let children come into contact with the tool or extension cord. Supervision is required for those under 16 years of age.

5 Use appropriate tool

The intended use is described in this instruction manual. Do not force small tools or attachments to do the job of a heavy-duty tool. The tool will do the job better and safer at the rate for which it was intended.

Warning! The use of any accessory or attachment or performance of any operation with this tool, other than those recommended in this instruction manual may present a risk of personal injury.

6 Maintain tools with care

Keep the tools in good condition and clean for better and safer performance. Follow the instructions for maintenance and changing accessories. Inspect the tool cords at regular intervals and, if damaged, have them repaired by an authorized DEWALT repair agent. Keep all controls dry, clean and free from oil and grease.

7 Store idle tools

When not in use, power tools must be stored in a dry place and locked up securely, out of reach of children.

8 Check for damaged parts

Before using the tool, carefully check it for damage to ensure that it will operate properly and perform its intended function. Check for misalignment and seizure of moving parts, breakage of parts and any other conditions that may affect its operation. Have damaged guards or other defective parts repaired or replaced as instructed.

Do not use the tool if the switch is defective.

Have the switch replaced by an authorized DEWALT repair agent.

9 Remove the batteries

Remove the batteries when not in use, before servicing and when changing accessories.

10 Have your tool repaired by an authorized DEWALT repair agent

This power tool is in accordance with the relevant safety regulations. To avoid danger, electric appliances must only be repaired by qualified technicians.

Additional safety instructions for rotary lasers

- This laser complies with class 2 according to EN 60825-1:1994+A11. Do not replace a laser diode with a different type. If damaged, have the laser repaired by an authorised repair agent.
- Do not use the laser for any purpose other than projecting laser lines.
An exposure of the eye to the beam of a class 2 laser is considered safe for a maximum of 0.25 seconds. Eyelid reflexes will normally provide adequate protection. At distances over 1 m, the laser complies with class 1 and thus is considered completely safe.
- Never look into the laser beam directly and intentionally.
- Do not use optical tools to view the laser beam.
- Do not set up the tool at a position where the laser beam can cross any person at head height.
- Do not let children come in contact with the laser.

Additional safety instructions for battery packs



Fire hazard! Avoid metal short circuiting the contacts of a detached battery pack. Do not store or carry the battery pack without the battery cap placed over the contacts.

- The battery fluid, a 25-30% solution of potassium hydroxide, can be harmful. In case of skin contact, flush immediately with water. Neutralize with a mild acid such as lemon juice or vinegar. In case of eye contact, rinse abundantly with clean water for at least 10 minutes. Consult a physician.
- Never attempt to open a battery pack for any reason.

Labels on charger and battery pack

In addition to the pictographs used in this manual, the labels on the charger and the battery pack show the following pictographs:

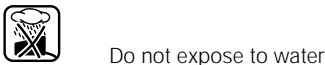
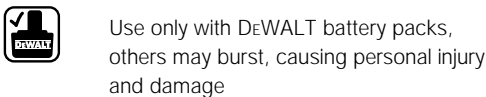
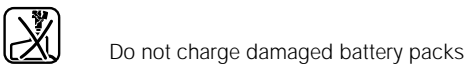
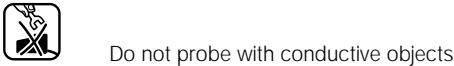

Have defective cords replaced immediately



Charge only between 4 °C and 40 °C



Discard the battery pack with due care for the environment



Do not incinerate the battery pack

Labels on tool

The following pictographs are shown on the tool:



Read the instruction manual before use



Laser warning



Safety warning: class 2 laser

Package contents

The package contains:

- 1 Rotary laser
- 1 Wall mount
- 1 Remote control
- 1 Target card
- 1 Pair of glasses
- 1 Kitbox
- 1 Charger
- 1 Battery pack
- 1 Instruction manual

- Take the time to thoroughly read and understand this manual prior to operation.

Description (fig. A)

The rotary laser DW077 has been designed to project laser lines to aid in professional applications. The tool can be used both inside and outside for horizontal (level) and vertical (plumb) alignment.

The tool can also produce a stationary laser dot that can be directed manually to establish or transfer a mark. The applications range from drop-ceiling installation and wall layout to foundation leveling and deck building.

The tool accepts DEWALT battery packs of 9.6, 12, 14.4 and 18 V.

- 1 On/off switch
- 2 Carrying handle
- 3 Leveling knob
- 4 Wall mount
- 5 Rack pinion locking knob
- 6 Wall mount clamp
- 7 Wall mount clamp lock
- 8 Fitting handle
- 9 Rack pinion wheel
- 10 Rotary laser head
- 11 Battery pack

Charger

Your DE9108 charger accepts DEWALT NiCd battery packs ranging from 7.2 V to 18 V.

Your DE9116 charger accepts DEWALT NiCd and NiMH battery packs ranging from 7.2 V to 18 V.

- 11 Battery pack
- 12 Release buttons
- 13 Charger
- 14 Charging indicator (red)

Display

- 15 Power indicator
- 16 Leveling indicator (X-axis)
- 17 Leveling indicator (Y-axis)
- 18 Scan mode activation key
- 19 Rotation speed setting key
- 20 Adjustment keys left/right

Remote control

- 18 Scan mode activation key
- 19 Rotation speed setting key
- 20 Adjustment keys left/right
- 21 Adjustment keys up/down
- 22 Manual adjustment key

Self-leveling feature

The self-leveling feature realises a quick adjustment of the rotary laser head in both level and plumb applications.

Initiated as the tool is switched on, the self-leveling feature will level the laser head in the described tool set-ups at ranges up to +/- 5°.

Electrical safety

The electric motor has been designed for various voltages (see technical data). Always check that the battery pack power corresponds to the voltage on the rating plate. Also make sure that the voltage of your charger corresponds to that of your mains.



Your DEWALT charger is double insulated in accordance with EN 60335.

Mains plug replacement (U.K. & Ireland only)

- Should your mains plug need replacing and you are competent to do this, proceed as instructed below. If you are in doubt, contact an authorized DEWALT repair agent or a qualified electrician.
- Disconnect the plug from the supply.
- Cut off the plug and dispose of it safely; a plug with bared copper conductors is dangerous if engaged in a live socket outlet.
- Only fit 13 Amperes BS1363A approved plugs fitted with the correctly rated fuse (1).
- The cable wire colours, or a letter, will be marked at the connection points of most good quality plugs. Attach the wires to their respective points in the plug (see below). Brown is for Live (L) (2) and Blue is for Neutral (N) (4).
- Before replacing the top cover of the mains plug ensure that the cable restraint (3) is holding the outer sheath of the cable firmly and that the two leads are correctly fixed at the terminal screws.

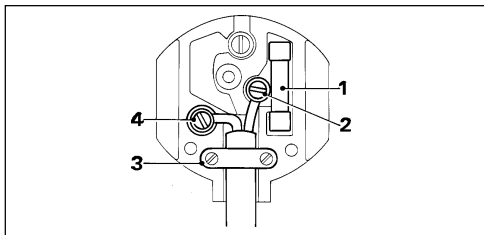

Never use a light socket.
Never connect the live (L) or neutral (N) wires to the earth pin marked E or \perp .

Using an extension cable

An extension cord should not be used unless absolutely necessary. Use an approved extension cable suitable for the power input of your charger (see technical data). The minimum conductor size is 1 mm²; the maximum length is 30 m.

Assembly and adjustment



- Prior to assembly and adjustment, always remove the battery pack.
- Always switch off the tool before inserting or removing the battery pack.
- Use only DEWALT battery packs and chargers.

Battery pack (fig. A & B1 - B4)

Charging the battery pack (fig. A)

When charging the battery pack for the first time, or after prolonged storage, it will only accept an 80% charge. After several charge and discharge cycles, the battery pack will attain full capacity.

Always check the mains prior to charging the battery pack. If the mains is functioning but the battery pack does not charge, take your charger to an authorised DEWALT repair agent. Whilst charging, the charger and the battery pack may become warm to touch.

This is a normal condition and does not indicate a problem.



Do not charge the battery pack at ambient temperatures < 4 °C or > 40 °C. Recommended charging temperature: approx. 24 °C.

- To charge the battery pack (11), insert it into the charger (13) as shown and plug in the charger. Be sure that the battery pack is fully seated in the charger. The red charging indicator (14) will blink. After approx. 1 hour, it will stop blinking and remain on. The battery pack is now fully charged and the charger automatically switches to equalise mode. After approx. 4 hours, it will switch to maintenance charge mode. The battery pack can be removed at any time or left in the connected charger indefinitely.
- The red charging indicator flashes rapidly to indicate a charging problem.

Reinsert the battery pack or try a new one. If the new pack also refuses to charge, have your charger tested by an authorized DEWALT repair agent.

- When plugged into power sources such as generators or sources that convert DC to AC, the red charging indicator may blink twice, switch off and repeat. This indicates a temporary problem of the power source. The charger will automatically switch back to normal operation.

Inserting and removing the battery pack (fig. B1)

- Insert the battery pack (11) into the tool until it clicks in place.
- To remove the battery pack, press the two release buttons (12) simultaneously and pull the pack out of the tool.

Battery cap (fig. B2)

A protective cap is supplied to cover the contacts of a detached battery pack. Without the protective cap in place, loose metal objects could short circuit the contacts, causing a fire hazard and damaging the battery pack.

- Take off the protective cap (12) before placing the battery pack (24) in the charger or tool.
- Place the protective cap over the contacts immediately after removing the battery pack from the charger or tool.



Make sure the protective cap is in place before storing or carrying a detached battery pack.

Equalization mode



The equalization mode helps to maintain the optimum capacity of the battery pack. It is therefore recommended to use the equalization mode weekly or every 10 charge/discharge cycles.

- Charge the battery pack as described above.
- When the charging indicator stops blinking, leave the battery in the charger for approx. 4 hours.

Hot Pack Delay

When the charger detects a battery that is hot, it automatically starts a Hot Pack Delay, suspending charging until the battery has cooled.

After the battery has cooled, the charger automatically switches to the pack charging mode. This feature ensures maximum battery life. The red indicator (14) blinks long, then short while in the Hot Pack Delay mode.

Battery type (fig. B3 & B4)

The tool is suitable for battery packs with different voltages.

- To fit battery packs of 18 volt, rotate the adapter plate (25) into position A.
- To fit battery packs of 9.6, 12 or 14.4 volt, rotate the adapter plate (25) into position B.

Refer to the table in the back for a selection of applicable battery packs.

Setting up the tool (fig. C1 - C5)

The tool facilitates various set-ups, making it useful for several applications.

Floor set-up (fig. C1)

- Place the tool on a relatively smooth and level surface.
- Adjust the tool for a level or plumb application.

Wall set-up (fig. C2 - C4)

The tool has been equipped with a wall mount (4) for mounting to a wall track to aid in drop ceiling installation and other specialty leveling projects (fig. C2).

- Fit the tool to the wall mount by inserting the threaded pin (23) into one of the receptacles in the tool and tightening the knob (8).
- Turn the tool on its side with the wall mount clamp (6) in position for attachment to the wall track (fig. C3).
- With the wall mount (4) facing the wall, turn the wall mount clamping lock (7) in the clockwise direction to open the clamp jaws.
- Place the clamp jaws around the wall track and turn the wall mount clamping lock (7) in the anti-clockwise direction to close the clamp jaws shut on the track.
- Ensure that the wall mount clamping lock (7) is securely locked.

- Alternatively, the tool can be hung on the wall using the mounting holes (27) in the wall mount (fig. C2).
 - Hold the tool at the desired position against the wall and mark the location of the two mounting holes on the wall (fig. C4).
 - Drill a hole at each of the marked locations (required: \varnothing 6 mm, approx. 35 mm deep).
 - Insert a corresponding plug into each of the holes.
 - Turn a screw into each of the plugs (required: 6 x 50 mm).
 - Hang the tool on the screws.
- Adjust the leveling knob (3) to stabilise the tool when necessary.
- Adjust the tool for a level application.

Tripod set-up (fig. C5)

The tool has been equipped with a tripod receptacle for mounting to the DE0736 tripod (optional) or any other tripod with the required ratings stated in the technical data.

- Place the tripod (28) on a relatively smooth and level surface.
- Mount the tool to the tripod by turning the threaded pin (29) into the receptacle (30) in the base.
- Adjust the tool for a level or plumb application.

Adjusting the tool (fig. A, D1 & D2)

The tool can be adjusted for both level (fig. D1) and plumb (fig. D2) applications.

Self-leveling feature (fig. A)

- To initiate the leveling procedure, switch on the tool. The leveling procedure is indicated by the flashing of the leveling indicators (16 & 17) and the laser beam. Once the tool has found its level position the leveling indicators and the laser beam will stop flashing and remain on.
- The leveling indicators and the laser beam repeatedly flash three times rapidly to indicate that the tool has been set up at a slope that is beyond the self-leveling range of 5°. Switch the tool off, re-adjust the tool set-up within the self-leveling range and switch the tool on again.

Level adjustment (fig. D1)

- Place the tool into the required position as shown.
- Switch on the tool to initiate the leveling procedure.



Before attaching the tool to a wall track ensure that the track is properly secured to the wall.

Plumb adjustment (fig. D2)

- Place the tool into the required position as shown.
- Switch on the tool to initiate the leveling procedure. As the leveling procedure for plumb applications only requires adjustment of the Y axis, only the corresponding leveling indicator (17) will be operational.

Manually adjusting the level position (fig. A)

By using the remote control the tool can be adjusted manually. The manual adjustment mode is particularly useful in applications with slope angles in both X and Y-axis.

- To activate the manual adjustment mode press the key (22). The leveling indicators (16 & 17) go off.
- Use the keys (20) to adjust the tool in the X-axis.
- Use the keys (21) to adjust the tool in the Y-axis.
- To discontinue the manual adjustment mode, press the key (22) again.



After discontinuing the manual leveling mode the self-leveling feature automatically takes over and re-adjusts the tool to level position. The manual adjustments will be lost immediately!

Aligning the laser line (fig. A & E1 - E5)**Level alignment**

- With the tool switched on and the laser head rotating, align the laser line with the position mark.
- If adjustment is required, proceed as follows:

With tool in floor set-up (fig. E1):

- The tool can be placed on any sturdy object to obtain the required height.

With tool in wall set-up (fig. E2):

- Loosen the locking knob (5) and adjust the rack pinion wheel (9) to set the tool to the correct position. Tighten the locking knob (5).

With tool in tripod set-up (fig. E3):

- Adjust the tripod to set the tool to the required height.

Plumb alignment (fig. A, E4 & E5)

- With the tool switched on and the laser head rotating, align the laser line with the position mark.
- If adjustment is required, proceed as follows:

- Use the keys (20) to move the laser head until the laser line aligns with the position mark (fig. A).

Slope alignment (fig. A)

If the application requires the laser line to align at a slope angle, proceed as follows:

- With the tool switched on and the laser head rotating, activate the manual leveling mode.
- Align the laser line with the slope:
 - Use the keys (20) to adjust the tool in the X-axis.
 - Use the keys (21) to adjust the tool in the Y-axis.

Instructions for use

Always observe the safety instructions and applicable regulations.

- Always mark the center of the laser line or dot.
- To increase working distance and accuracy, set up the tool in the middle of your working area.
- Make sure the tool has been set up securely.
- Extreme temperature changes cause movement of internal parts that may affect the accuracy of the tool. Regularly check the accuracy while using the tool under these circumstances.
- Although the tool corrects small out-of-level errors automatically, when it has registered a bump, re-adjustment to balance or set-up may be required.
- If the tool has been dropped or has tipped over, have the laser head calibrated by a qualified repair agent.
- For your own comfort, always use the remote control to operate the tool. The remote control not only allows you to operate the tool from a distance, it also keeps you from touching the tool, thereby reducing the risk of affecting the tool's balance and set-up.

Switching on and off (fig. A)

- To switch the tool on, press the on/off switch (1).
- To switch the tool off, press the on/off switch (1) again.

Setting the rotation speed (fig. F)

The laser head can be set to different rotation speed settings, thus determining the quality of the line.

- Press the key (19). The rotation speed will cycle from “fast” to “medium”, “slow”, “crawling” and “stationary” each time the key is pressed.
- For a bright line, set the laser head to a slow rotation speed.
- For a solid line, set the laser head to a fast rotation speed.

Rotating the laser head (fig. G1 & G2)

In the stationary position, the laser head can be moved both to the left and to the right.

Level applications:

- Use the keys (20) to move the laser head into the required direction.

Plumb applications:

- Use the keys (21) to move the laser head into the required direction.

Manually rotating the laser head (fig. G2)

The laser head can also be rotated manually.

- Turn the laser head (10) into the required position.



Do not attempt to move the laser head while it is rotating at a preset rotation speed.

Scan mode (fig. H)

The laser head can be set to different speed settings while moving back and forth, thus projecting a scanning laser line.

- Press the key (18) to activate the scan mode. The scan speed starts at “fast” rate.
- To set the scan speed press the key (19). The scan speed will cycle from “crawling” to “slow”, “medium” and “fast” each time the key is pressed.
- Level applications:
 - Use the keys (20) to move the scan area into the required direction.
 - Use the keys (21) to adjust the scan area.
- Plumb applications:
 - Use the keys (21) to move the scan area into the required direction.
- Press the key (18) to discontinue the scan mode.

Out-of-level alert

The out-of-level alert activates automatically 8 seconds after the leveling procedure has been completed. Once the out-of-level alert is activated, the tool monitors its level position continuously. Depending on the registered level of deviation the tool will respond to level errors as follows:

- Deviations < 2 mm over 10 m: a level error is automatically corrected without notifying.
- Deviations 2 - 20 mm over 10 m: a level error is automatically corrected. The laser head temporarily stops rotating and the laser beam starts flashing to indicate that the tool re-adjusts to level position.
- Deviations > 20 mm over 10 m: a level error leads to interruption of the tool’s operation. The laser head stops rotating and the laser beam goes off. A rapidly beeping audio signal is produced and the on/off indicator flashes simultaneously. To resume the operation:
 - Switch the tool off. Check the balance and set-up and re-adjust if required before switching the tool on again.

Tool aids (fig. I1 - I4)

Several aids have been supplied that might be helpful while operating the tool.

Remote control (fig. I1)

The remote control allows a manual intervention of the self-leveling feature when slope adjustment is required. The maximum slope angle corresponds to the self-leveling range of the tool.

The remote control also allows you to activate the laser line and control the laser head from distances up to 30 m radius.

Laser enhancement glasses (fig. I2)

The red lens glasses improve the visibility of the laser beam under bright light conditions or over long distances. Providing best results indoors, the lens filters out ambient light and intensifies the projected dot or line. The glasses do not keep the laser beam from entering the eyes.



Never look into the laser beam directly with these glasses.

DE0730 Target card (fig. I3)

The target card locates and marks the laser beam as the beam crosses the card, thus enhancing the visibility of the projected line. The laser beam passes through the red plastic surface and is reflected by the reflective rear side of the card. Supporting easy use during plumb and level adjustment, the card is marked with inch and metric scales, and has magnets at the top to hold it to ceiling track or steel studs.

Wall mount (fig. I4)

The wall mount may also be used as a base to provide extra stability for the tool.

Optional accessories

Consult your dealer for further information on the appropriate accessories.

These are:

- DE0772 Digital laser detector
- DE0734 Grade rod
- DE0736 Tripod

Battery packs

Voltage	NiCd	NiMH
9.6	DE9061	DE9036
12	DE9071	DE9037
14.4	DE9091	DE9038
18	DE9095	DE9039

Maintenance

Your DEWALT Power Tool has been designed to operate over a long period of time with a minimum of maintenance. Continuous satisfactory operation depends upon proper tool care and regular cleaning.

Field calibration check

The field calibration checks must be performed securely and accurately to make a correct diagnosis. Whenever an error is registered, have the tool calibrated by a qualified repair agent.



Always have the laser head calibrated by a qualified repair agent.

Level checks

The following checks are performed to check the calibration of laser head for level alignment.

- Place the tool in an area at about 15 m from a vertical surface.
- With the tool in a tripod set-up, adjust the tool for a level application.

To perform a level check of the X-axis:

- Position the tool so that the X-axis is parallel with the vertical surface.
- Switch on the tool and rotate the head until the laser dot appears on the vertical surface.
- Mark the centre of the laser beam. Switch off the tool.
- Switch off the tool and rotate it 180° so that the X-axis is parallel with the vertical surface the other way around.
- Switch on the tool, rotate the head and once again mark the centre of the laser dot on the surface. Switch off the tool.
- Measure the difference between the markings.
- If the difference between the markings is 3.2 mm or less, the laser head is properly calibrated.
- If the difference between the markings is more than 3.2 mm, the laser head must be calibrated.

To perform a check of the Y-axis:

- Position the tool so that the Y-axis is parallel with the vertical surface.
- Following the same procedure as described above, mark the centre of the laser dot on the surface with the tool in this position, after which the tool is rotated 180° to mark the centre of the laser dot once again.
- Measure the difference between the markings.
- If the difference between the markings is 3.2 mm or less, the laser head is properly calibrated.
- If the difference between the markings is more than 3.2 mm, the laser head must be calibrated.

Plumb check

The following check is performed to check the calibration of laser head for plumb alignment.

- Place the tool in an area at about 1 m from a vertical surface.
- With the tool in a floor set-up, adjust the tool for a plumb application.
- Mark the top and bottom of the vertical surface using a plumb bob.
- Switch on the tool and align the laser beam with the lower marking.
- Using the remote control, move the head until the laser beam is at the upper marking.

- If the laser beam aligns with the top marking, the laser head is properly calibrated.
- If the laser beam does not align with the top marking, the laser head must be calibrated.



Cleaning

- Unplug the charger before cleaning the housing with a soft cloth.
- Remove the battery pack before cleaning your power tool.
- Keep the ventilation slots clear and regularly clean the housing with a soft cloth.
- When necessary, clean the lens using a soft cloth or a cotton bud soaked in alcohol. Do not use any other cleaning agents.

Environment



Rechargeable battery pack

This long life battery pack must be recharged when it fails to produce sufficient power on jobs which were easily done before. At the end of its technical life, discard it with due care for our environment:

- Run the battery pack down completely, then remove it from the tool.
- NiCd and NiMH cells are recyclable. Take them to your dealer or a local recycling station. The collected battery packs will be recycled or disposed of properly.



Unwanted tools

Take your tool to an authorised DeWALT repair agent where it will be disposed of in an environmentally safe way.

GUARANTEE

• 30 DAY NO RISK SATISFACTION GUARANTEE •

If you are not completely satisfied with the performance of your DeWALT tool, simply return it within 30 days, complete as purchased, to the point of purchase, for a full refund or exchange. Proof of purchase must be produced.

• ONE YEAR FREE SERVICE CONTRACT •

If you need maintenance or service for your DeWALT tool, in the 12 months following purchase, it will be undertaken free of charge at an authorized DeWALT repair agent. Proof of purchase must be produced. Includes labour and spare parts for Power Tools. Excludes accessories.

• ONE YEAR FULL WARRANTY •

If your DeWALT product becomes defective due to faulty materials or workmanship within 12 months from the date of purchase, we guarantee to replace all defective parts free of charge or, at our discretion, replace the unit free of charge provided that:

- The product has not been misused.
 - Repairs have not been attempted by unauthorized persons.
 - Proof of purchase date is produced.
- This guarantee is offered as an extra benefit and is additional to consumers statutory rights.

For the location of your nearest authorized DeWALT repair agent, please use the appropriate telephone number on the back of this manual. Alternatively, a list of authorized DeWALT repair agents and full details on our after-sales service are available on the Internet at www.2helpU.com.

Belgique et Luxembourg België en Luxemburg	DeWALT Weihoek 1, Nossegem 1930 Zaventem-Zuid	Tel: 02 719 07 11 Fax: 02 721 40 45 www.dewaltbenelux.com
Danmark	DeWALT Hejrevang 26 B 3450 Allerød	Tlf: 70 20 15 30 Fax: 48 14 13 99 www.dewalt-nordic.com
Deutschland	DeWALT Richard-Klinger-Straße 65510 Idstein	Tel: 06126-21-1 Fax: 06126-21-2770 www.dewalt.de
Ελλάς	BLACK & DECKER (ΕΛΛΑΣ) Α.Ε. Στραβωνος 7 & Λεωφ. Βουλιαγμένης 159 166 74 Γλυφάδα - Αθήνα	Τηλ. 010 8981616 010 8982630 Φαξ 010 8983285
España	DeWALT Parque de Negocios "Mas Blau" Edificio Muntadas, c/Bergadá, 1, Of. A6 08820 El Prat de Llobregat (Barcelona)	Tel: 934 797 400 Fax: 934 797 439
France	DeWALT Le Paisy BP 21, 69571 Dardilly Cedex	Tel: 472 20 39 72 Fax: 472 20 39 02
Helvetia Schweiz	DeWALT ROFO Kundendienst Gewerbezone Seeblick 3213 Kleinbösingen	Tel: 026 - 674 93 93 Fax: 026 - 674 93 94 www.dewalt.ch
Ireland	DeWALT Calpe House Rock Hill Black Rock, Co. Dublin	Tel: 00353-2781800 Fax: 00353-2781811
Italia	DeWALT Viale Elvezia 2 20052 Monza (Mi)	Tel: 0800-014353 Fax: 039-2387592
Nederland	DeWALT Florijnstraat 10 4879 AH Etten-Leur	Tel: 076 50 02 000 Fax: 076 50 38 184 www.dewalt.benelux.com
Norge	DeWALT Strømsveien 344 1011 Oslo	Tel: 22 99 99 00 Fax: 22 99 99 01 www.dewalt-nordic.com
Österreich	DeWALT Werkzeugevertriebs GmbH Erlaerstraße 165, Postfach 320,1231 Wien	Tel: 01 - 66116 - 0 Fax: 01 - 66116 - 14 www.dewalt.at
Portugal	DeWALT Rua Egas Moniz 173 João do Estoril, 2766-651 Estoril	Tel: 214 66 75 00 Fax: 214 66 75 75
Suomi	DeWALT Palotie 3 01610 Vantaa	Puh: 98 25 45 40 Fax: 98 25 45 444 www.dewalt-nordic.com
	Brandvägen 3 01610 Vanda	Tel: 98 25 45 40 Fax: 98 25 45 444 www.dewalt-nordic.com
Sverige	DeWALT Box 603 421 26 Västra Frölunda, Besöksadr. Ekonomivägen 11	Tel: 031 68 61 00 Fax: 031 68 60 08 www.dewalt-nordic.com
Türkiye	DeWALT Merkez Mahallesi, Köyaltı Mevkii, Şahnur Sokak (OTTO Binası) 34530 Yenibosna/İstanbul (PBX)	Tel: 021 26 39 06 26 Faks: 021 26 39 06 35
United Kingdom	DeWALT 210 Bath Road Slough, Berks SL1 3YD	Tel: 01753-56 70 55 Fax: 01753-57 21 12