

Crestron Isys™ **TPS-4500V** and **TPS-4500LV**
12 Inch Tilt and Lectern Touchpanels with Video

Operations Guide



CRESTRON

This document was prepared and written by the Technical Documentation department at:



Crestron Electronics, Inc.
15 Volvo Drive
Rockleigh, NJ 07647
1-888-CRESTRON

Contents

12 Inch Tilt/Lectern Touchpanels with Video: TPS-4500V & TPS-4500LV	1
Introduction	1
Features and Functions	1
Specifications	2
Physical Description	4
Position Lock Buttons (TPS-4500V only)	7
Industry Compliance	8
Setup	9
Network Wiring	9
Identity Code	10
Configuring the Touchpanel	10
Hardware Hookup	14
Touchpanel Mounting Options for TPS-4500LV	19
Touchpanel Removal (TPS-4500LV)	22
Recommended Cleaning	22
Programming Software	23
Programming with the Crestron AppBuilder	24
Programming with SIMPL Windows	24
Programming with VisionTools® Pro-e	28
Reserved Join Numbers	30
MultiByte International Characters	32
Uploading and Upgrading	32
Communication Settings	33
Uploading a SIMPL Windows Program	35
Uploading a VT Pro-e Project	36
Firmware Upgrade	38
Problem Solving	40
Troubleshooting	40
Further Inquiries	41
Future Updates	41
Appendix A: RS-232 Protocol	42
Appendix B: Cutout Detail of Supplied Template	44
Appendix C: Configuring the RS-232 Port for Use	45
Obtaining Communications	45
Configuration Options	45
RS-232 Port Configuration	45
Software License Agreement	47
Return and Warranty Policies	49
Merchandise Returns / Repair Service	49
CRESTRON Limited Warranty	49

12 Inch Tilt/Lectern Touchpanels with Video: TPS-4500V & TPS-4500LV

Introduction

Features and Functions

The TPS-4500V and TPS-4500LV (known collectively as the TPS-4500V/LV) series packs all the power and performance of a Crestron Isys™ touchpanel in a stylish tilt or lectern model. Its size and capabilities make it perfect for the conference room and home theater.

TPS-4500V/LV Functional Summary

- 12" (30.5 cm) diagonal active matrix color display
- 800 x 600 native screen resolution
- 16 Bit non-palette graphics, over 64,000 colors
- 4 Mb of Flash, expandable to 32 Mb with Crestron® plug-in memory modules & 8 Mb of DRAM memory
- Displays one NTSC/PAL/S-video/composite video source with 262,142 colors with the built-in TPS-VID/L-1 video card
- Up to 4,000 digital and analog signal joins; Up to 999 serial signal joins
- Local RS-232 port for console control
- Pop-up sub panels to reduce memory requirements, providing optimal speed and performance
- Multiple button, slider control, and icon configurations, including multi-mode objects
- Fast graphics performance: imported photographs, drawings, and icons
- Support for downloadable fonts – proportional and non-proportional
- Foreign language text
- Position Lock feature provides durable support of panel at any angle of inclination between 30 and 80 degrees (TPS-4500V only)

The TPS-4500LV is available in two different colors: black, or white. The suffixes 'B' or 'W' respectively denotes color; i.e. TPS-4500LVB is a touchpanel with a black faceplate. For simplicity within this guide, color suffix is omitted. The TPS-4500 is black.

Featuring a 12-inch (30.5 cm) active matrix display the TPS-4500V/LV uses the 65,536-color Isys engine, which allows all graphics to be displayed with incredible brightness and depth.

Multiple graphics can be displayed on the TPS-4500V/LV without any shift in color depth or quality. The touchpanel supports real-time video with the built-in TPS-VID-1 (VIDL-1 for the 4500LV) video digitizer card.

The purpose of the TPS-4500V/LV touchpanel is to replace large, complicated hard-wired panels in either a Cresnet® system or an RS-232 system with a series of simpler screens each specific to the control problem at hand. Thus, a very large number of functions can be made available to the user without the confusion associated with hardware panels of that complexity. Icons, graphics, and text can dramatically increase any user's comprehension of the control environment. Devices, functions, and control zones are quickly organized and more easily accessed.

The TPS-4500V/LV has the ability to transmit touch coordinates when “RS-232 Port for Touch Output” is selected. Currently Telestrator devices are supported on the TPS-4500V/LV. Refer to the “RS-232 Menu” section of “Configuring the Touchpanel” on page 13 and “Appendix C: Configuring the RS-232 Port for Use” on page 45 for instructions on selecting this feature.

Specifications

The following provides a summary of specifications for the TPS-4500V/LV touchpanel.

Specifications for the TPS-4500V/LV Touchpanel

SPECIFICATION	DETAILS
Power Requirements	27 Watts (1.13 Amp @ 24 VDC)
Default Net ID	03
Timeout	Adjustable from 0 to 120 minutes (Default = 15 min.)
Signal Join Maximums	4000 Digital and Analog, 999 Serial
Video Types	NTSC or PAL
Video Formats	Composite or S-video
Video Format Detection	Within 2 seconds
Control System Update Files ^{1,2,3}	
2-Series Control System	Version C2-2004.CUZ or later ²
CEN/CN-TVAV	Version 51130V.UPZ or later ⁴
CNMSX-AV/PRO	Version 51125X.UPZ or later ⁴
CNRACKX/-DP	Version 51125W.UPZ or later ⁴
ST-CP	Version 4.00.49S.UPZ or later ⁵
Touchpanel Firmware	TPS.V.2.000.0.csf or later
Memory	4MB internal flash memory (upgradeable to 32MB), 8MB of DRAM ⁶
Screen Dimensions	12"/30.1 cm diagonal
Screen Viewing Angles:	Y Dir. (X=0°): +45° (from top), -55° (from bottom) X Dir. (Y=0°): +60° (from right), -60° (from left)

(continued on next page)

Specifications for the TPS-4500V/LV Touchpanel (continued)

SPECIFICATION	DETAILS
Screen Resolution	800 x 600 pixels
Color	16 Bit non-palette graphics with color key video window capability, 65,536 colors
Display Type	Touch-sensitive active matrix color LCD
Enclosure	TPS-4500LV: Black metal enclosure with injection-molded plastic faceplate in black or white TPS-4500V: high impact, black molded plastic enclosure
CPU	63MIPs Coldfire processor running Isys generation firmware
Cresnet	Via 4-pin Cresnet connector
RS-232	RJ-11 connector for console, telestrator, etc. Default settings: 115200, 8 bit, parity none, stop bit 1.
Operating Temperature and Humidity	50° to 113° F (10° to 45° C), 10 to 90% Relative Humidity (non-condensing)
Dimensions and Weight	
TPS-4500LV (with faceplate)	Height: 11.04 in (28.05 cm) Width: 13.43 in (34.11 cm) Depth: 2.70 in (6.85 cm) Weight: 6.0 lbs (2.75 kg)
TPS-4500V	Height: 11.86 in (30.12 cm) Width: 13.26 in (33.69 cm) Depth: 11.17 in (28.36 cm) Weight: 7.7 lbs (3.53 kg)

- 1 The latest versions can be obtained from the Downloads | Software Updates section of the Crestron website (www.crestron.com). Refer to NOTE after last footnote.
- 2 Crestron 2-Series control systems include the AV2, CP2, CP2E, MP2, MP2E, PAC2, PRO2, and RACK2.
- 3 CNX update files are required for either CNMSX-AV/PRO or CNRACKX/-DP. Filenames for CNX update files have a UPZ extension and ST-CP files are in one EXE or zipped UPZ file. To avoid program problems, make certain you are using the update file with the correct suffix letter (e.g., S, V, W, X).
- 4 When loading VT Pro-e files or firmware through the RS-232 port of the control system, be sure that the baud rate is at 38400 (Cresnet speed) or lower. Otherwise, the Viewport may post the "Transfer Failed" message.
- 5 These control systems do not support loading of firmware or VT Pro-e files to the TPS-series panels through the RS-232 port of the control system. In order to load these files to the touchpanel when using these control systems use the RS-232 port on the TPS-4500V/LV.
- 6 Additional Flash memory can be purchased, refer to "Memory" on page 7. The complexity of the control screens and the sampling of the WAV files influence memory usage.

NOTE: Crestron software and any files on the website are for Authorized Crestron dealers and Crestron Authorized Independent Programmers (CAIP) only. New users may be required to register to obtain access to certain areas of the site (including the FTP site).

Physical Description

The TPS-4500LV's 12-inch (30.5-cm) touch sensitive viewing screen is located on the front of the TPS-4500LV touchpanel, shown below and on the next page. The electronic hardware is housed in a black metal enclosure. All video, RS-232, and network connections are made at the rear of the unit. Two color bezels are available: black (TPS-4500LVB) and white (TPS-4500LVW).

Physical Views of the TPS-4500LV Touchpanel (Front & Side)

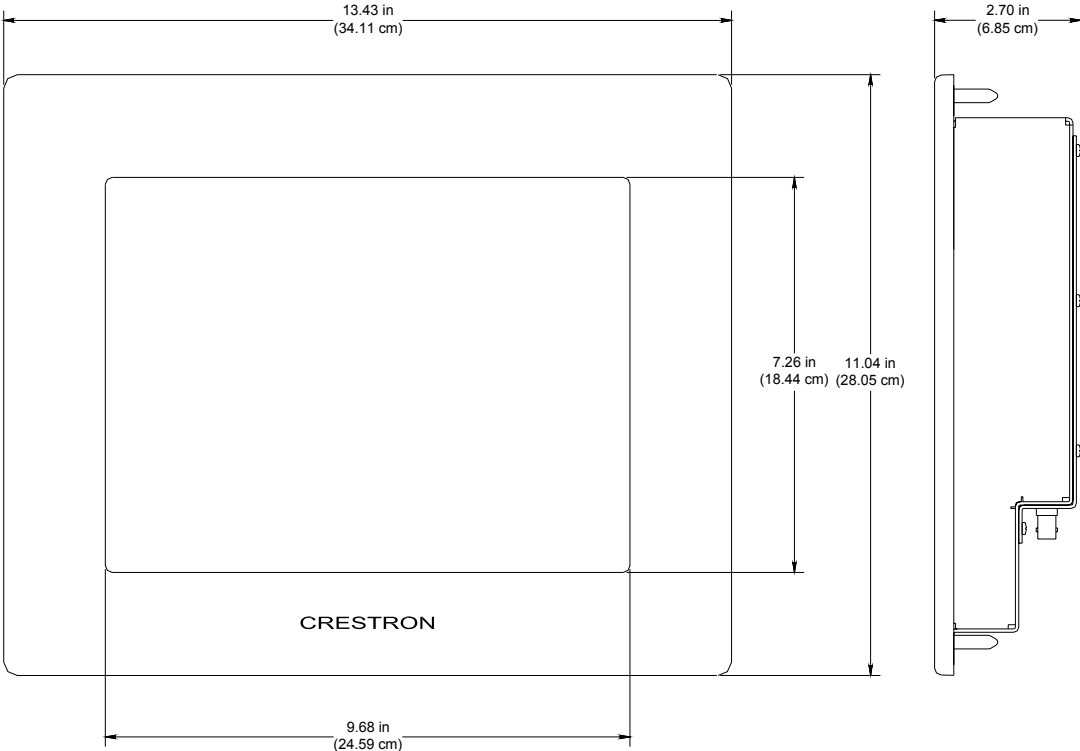

NOTE: For cutout dimensions, refer to “Appendix B: Cutout Detail of Supplied Template” on page 44.

Physical Views of the TPS-4500LV Touchpanel (Rear and Bottom)

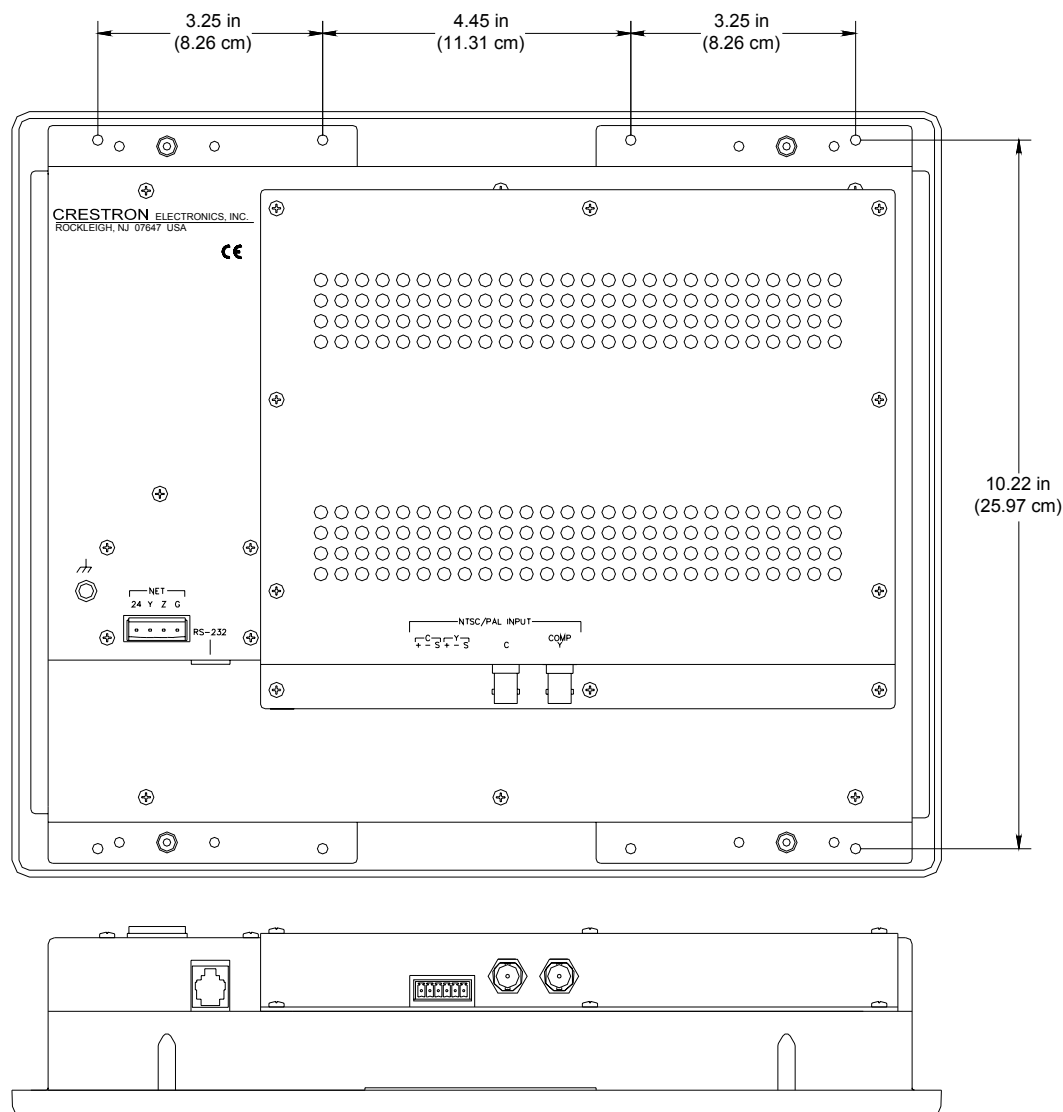

The TPS-4500V’s 12-inch (30.5-cm) touch sensitive viewing screen is located on the front of the TPS-4500V touchpanel. The electronic hardware is housed in a high impact, black molded plastic enclosure, shown in the following diagram. This touchpanel is designed for placement on a counter. It possesses a hinged base, which can tilt from 30 to 80 degrees. Refer to “Position Lock Buttons (TPS-4500V only)” on page 7 for tilting details. All RS-232, video, network, and power connections are made at the rear panel on the base of the unit.

NOTE: Video and network signals are connected to either the TPS-4500IMPC or TPS-4500IMW touchpanel interface modules. For more information on video connections, refer to “Video” on page 18.

Physical Views of the TPS-4500V Touchpanel (Front and Back)

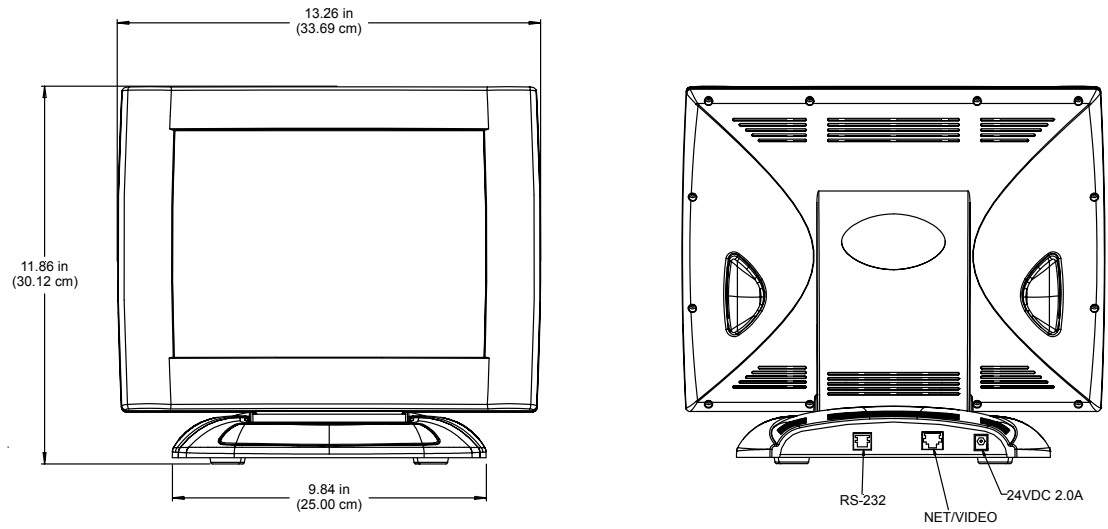

Physical Views of the TPS-4500V Touchpanel (Top and Bottom)

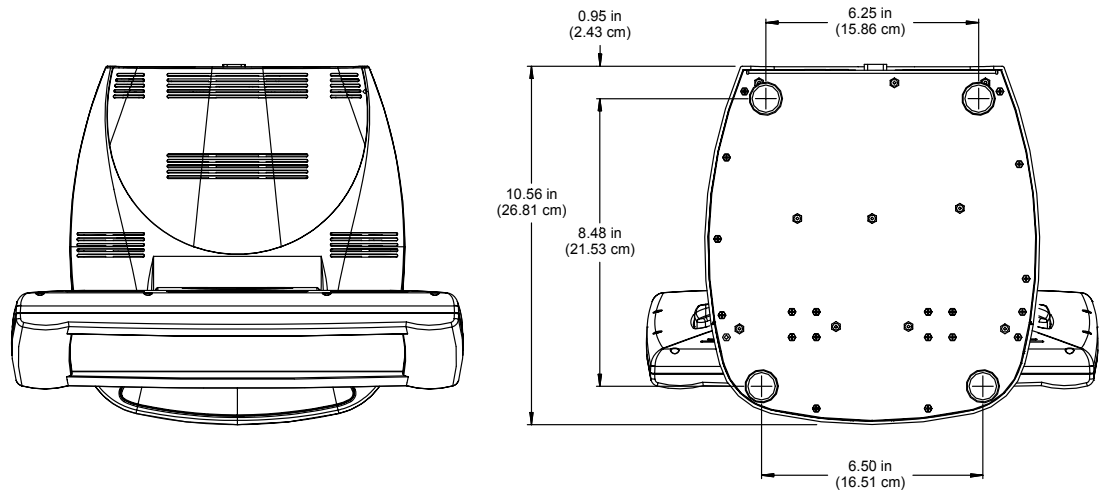

Physical Views of the TPS-4500V Touchpanel (Side with Min. and Max. Angle)

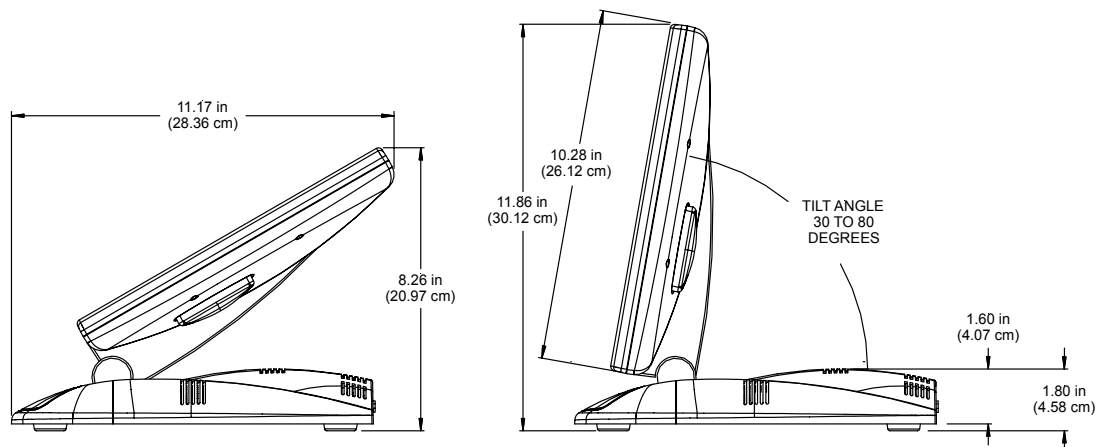

Video

The TPS-4500V/LV comes with a TPS-VID-1 single source video digitizer card that can display an S-video or composite video signal in a touchpanel project. For more information on configuring the touchpanel to display video signals, refer to “Video Menu” on page 13.

Memory

The TPS-4500V/LV ships with 4MB of flash and 8MB of DRAM memory. Additional memory by Crestron can be purchased separately and installed in the field. Refer to the latest revision of the Flash Memory for TPS User Interfaces Installation Guide (Doc. 5927) for an installation procedure.

Interface Modules (TPS-4500V only)

Connect the TPS-4500V to an outboard interface module, which provides expanded network/video connections for the touchpanel system. The connecting cable assemblies are supplied. There are two interface modules available: TPS-4500IMPC and TPS-4500IMW.

The TPS-4500IMPC is supplied with every TPS-4500V. This module is housed in a black enclosure with a silk-screened top panel and several I/O ports. At the shorter sides of the unit, the enclosure extends to form feet at a right angle to the side. These feet have mounting holes. Consult the latest revision of the TPS-4500IMPC Operations Guide (Doc. 6163, included with the TPS-4500V touchpanel) for more details.

The TPS-4500IMW is not provided with the TPS-4500V; it must be purchased separately. This unit installs into a one-gang electrical box (2.5-inch depth minimum). A decorator style wallplate can be mounted over the unit once it is installed to offer a more eye-pleasing appearance compared to the TPS-4500IMPC. Consult the latest revision of the TPS-4500IMW Operations Guide (Doc. 5913) for more details.

Position Lock Buttons (TPS-4500V only)

These buttons are used to make angular adjustments to the touchpanel screen. Each incremental angular position is indicated by an audible click (unless the position lock button is held down). Two position lock buttons are located on the backside of the touchscreen, shown after this paragraph. The two buttons function together so that if one is held down, the other is held down as well. This makes tilting the touchpanel comfortable for left and right-hand users. Furthermore, button position allows for one-hand tilting.

Location of Position Lock Buttons

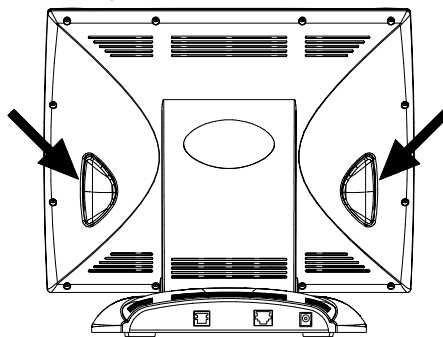

Range of motion is adjustable for user comfort and can vary from 30 to 80 degrees of inclination from the horizontal. Thus each user can position the touchscreen to a comfortable angle, just as a microphone can be repositioned to a suitable height for each speaker. The comfortable angle is herein referred to as user position. The position lock guarantees that once a user position is established or locked, the angle will not change from repeated presses on the touchscreen.

The touchscreen is free to move up from the nearly horizontal position to a larger incremental angle. Grasp the touchscreen with a hand at each side (or just one hand at either side, as shown after this paragraph) and gently tilt up to a comfortable position. To activate position lock, slightly reverse the motion until the touchpanel stops moving. The touchscreen is now set into user position.

NOTE: If the position lock button is held down as the screen is tilted, there are no audible clicks.

Two-Hand Placement for Tilting a Touchpanel to a Vertical Position

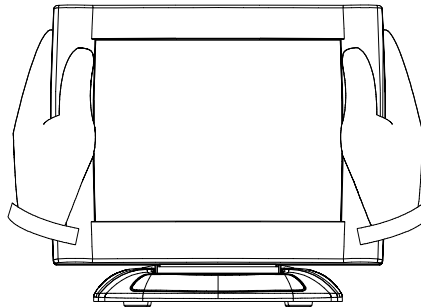

Once in user position, position lock is activated which means the touchscreen cannot be forced to a horizontal position without pressing the position lock button(s). The touchscreen is still free to tilt up; a new user position is established at each increment or audible click.

A position lock button needs to be pressed before the touchscreen can be returned to a more horizontal position. To press the button, slightly position the touchscreen in the vertical direction with one or two hands, avoiding any horizontal movement. The position lock button can then be held down and the touchscreen can be tilted to a more horizontal position.

Industry Compliance

As of the date of manufacture, the touchpanel have been tested and found to comply with specifications for CE marking and standards per EMC and Radiocommunications Compliance Labelling (N11785).



NOTE: This device complies with part 15 of the FCC rules. Operation is subject to the following two conditions: (1) this device may not cause harmful interference, and (2) this device must accept any interference received, including interference that may cause undesired operation.

Setup

Network Wiring

CAUTION: Use only Crestron power supplies for Crestron equipment. Failure to do so could cause equipment damage or void the Crestron warranty.

CAUTION: Possible equipment damage if miswired.

NOTE: When installing network wiring, refer to the latest revision of the wiring diagram(s) appropriate to your specific system configuration, available from the Downloads | Product Manuals | Wiring Diagrams section of the Crestron website (www.crestron.com).

NOTE: Do not power up system until all wiring is verified. Care should be taken to ensure data (Y, Z) and power (24, G) connections are not crossed.

NOTE: All network wiring must consist of two twisted-pairs. One twisted pair is the +24V conductor and the GND conductor and the other twisted pair is the Y conductor and the Z conductor.

When calculating the wire gauge for a particular Cresnet run, the length of the run and the power factor of each Cresnet unit to be connected must be taken into consideration. If Cresnet units are to be daisy-chained on the run, the power factor of each network unit to be daisy-chained must be added together to determine the power factor of the entire chain. The length of the run in feet and the power factor of the run should be used in the following resistance equation to calculate the value on the right side of the equation.

Resistance Equation

$$R < \frac{40,000}{L \times PF}$$

Where: R = Resistance (refer to table below).
L = Length of run (or chain) in feet.
PF = Power factor of entire run (or chain).

The required wire gauge should be chosen such that the resistance value is less than the value calculated in the resistance equation. Refer to the table after this paragraph.

Wire Gauge Values

RESISTANCE (R)	WIRE GAUGE
4	16
6	18
10	20
15	22
13	Doubled CAT5
8.7	Tripled CAT5

NOTE: All network wiring must consist of two twisted pairs. One twisted pair is the +24V conductor and the GND conductor. The other twisted pair is the Y and Z conductors.

NOTE: When daisy-chaining Cresnet units, strip the ends of the wires carefully to avoid nicking the conductors. Twist together the ends of the wires that share a pin on the network connector, and tin the twisted connection. Apply solder only to the ends of the twisted wires. Avoid tinning too far up the wires or the end becomes brittle. Insert the tinned connection into the Cresnet connector and tighten the retaining screw. Repeat the procedure for the other three conductors.

NOTE: For larger networks (i.e., greater than 28 network devices), it may become necessary to add a Cresnet Hub/Repeater (CNXHUB) to maintain signal quality throughout the network. Also, for networks with lengthy cable runs, it may be necessary to add a Hub/Repeater after only 20 devices.

Identity Code

Every equipment and user interface within the network requires a unique identity code (Net ID). These codes are two-digit hexadecimal numbers ranging from 03 to FE. Refer to “Interface Menu” on page 12 for instructions on setting the unit's Net ID. The Net ID of each unit must match an ID code specified in the SIMPL Windows program. Refer to “Setting the Net ID in Device Settings” on page 25 for details of the SIMPL Windows procedure.

Configuring the Touchpanel

NOTE: The only connection required to configure the touchpanel is power. Refer to “Hardware Hookup” on page 14 for details.

MAIN MENU

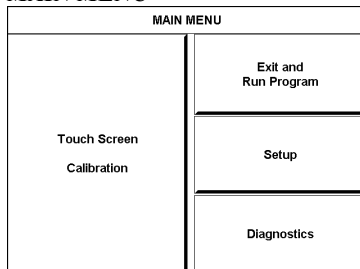

This menu can also be obtained via digital reserved join number, 17242.

To configure the unit, it may be necessary to access a series of setup screens prior to viewing run-time screens that are loaded into the touchpanel for normal operation. The MAIN MENU for configuring the touchpanel appears when a finger is held to the touchscreen as power is applied. Remove your finger when the message “SETUP MODE” appears on the touchscreen.

NOTE: The SETUP MODE can also be accessed through the Viewport Utility if the touchpanel is connected directly to a PC.

Upon entering SETUP MODE, the MAIN MENU, shown to the left, displays four buttons: **Touch Screen Calibration**, **Exit and Run Program**, **Setup**, and **Diagnostics**.

The **Exit and Run Program** button verifies that all of the setup information has been saved to EEPROM and displays the main page that has been programmed into your system. The remaining buttons on the MAIN MENU open other menus, which are discussed in subsequent paragraphs.

Calibration Menu

CALIBRATION MENU

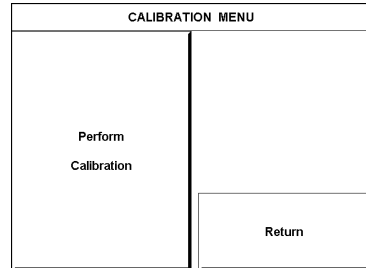

Calibration of the touchscreen is required if the active touch area of a button does not coincide with the button's image. Select the **Touch Screen Calibration** button to display the CALIBRATION MENU, shown to the left. The CALIBRATION MENU offers the choice to initiate calibration with the **Perform Calibration** button or return to the previous screen with the **Return** button. Choose an option by touching the correct button.

If you proceed to calibrate the touchpanel, the screen displays the message “Touch Upper Left” centered on the panel with a cross hair in the corner. Touch the cross hair in the corner of the screen to initiate calibration. Another message, “Touch Upper Right”, appears with a cross hair in the correct corner. Touch the corner of the screen. A final message, “Touch Lower Right”, appears with a cross hair in the correct corner. Touch the corner of the screen to conclude calibration and return to the MAIN MENU.

NOTE: When touching the screen during calibration, be as accurate as possible. Use the tip of a capped pen or the eraser end of a pencil. To cancel calibration and return to the CALIBRATION MENU without saving calibration data, create a calibration error by touching the screen in an area that is opposite from the instructed area.

Setup Menu

SETUP MENU

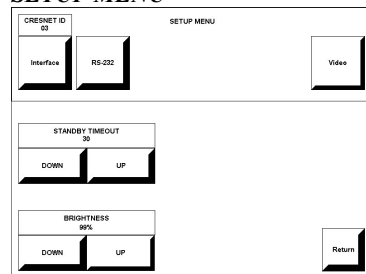

To access the SETUP MENU, shown to the left, press the **Setup** button from the MAIN MENU. The SETUP MENU offers a series of buttons, which opens additional menus and displays, which are detailed in subsequent paragraphs. Many touchpanel options (i.e., standby timeout and brightness) are available directly from the SETUP MENU and are explained in the following paragraphs. Other setup parameters (i.e., interface, RS-232, and video) use additional menus and are detailed in subsequent paragraphs as well. After setup parameters have been set, select the **Return** button to return to the MAIN MENU.

NOTE: The current CRESNET ID (a.k.a. Net ID) setting is displayed in the upper left corner of the SETUP MENU.

NOTE: All touchpanel settings are automatically saved in non-volatile memory.

The touchpanel display can be turned off (standby mode) when not in active use. **STANDBY TIMEOUT**, located in the middle of the SETUP MENU, can turn off the touchpanel when it is inactive for a specified time frame (minutes, shown as 30 in the illustration). When the touchpanel is activated, the last screen to be displayed reappears. Minutes can vary from 0 to 120, where 0 disables the timeout. **DOWN** and **UP** buttons decrease and increase the timeout, respectively.

Screen brightness may need to be altered because of ambient light conditions or personal preference. **BRIGHTNESS**, located in the lower left corner of the SETUP MENU, can change the brightness level of the display. The current brightness setting is shown as a percentage in the SETUP MENU (e.g., 99% brightness is shown in the illustration). Percentage can vary from 0% (low brightness) to 100% (full brightness). **DOWN** and **UP** buttons decrease and increase the brightness, respectively.

Interface Menu

INTERFACE MENU

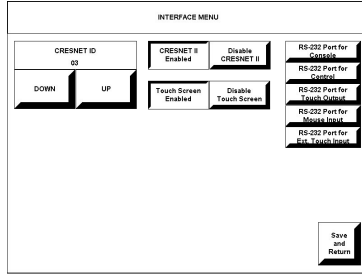

The touchpanel communicates with a control system to activate commands or to display feedback from components within the system. The communication interface must be correctly specified or communication will not occur. To set communication parameters select the **Interface** button located on the SETUP MENU and display the INTERFACE MENU, shown to the left.

The Cresnet network identity number (CRESNET ID) is displayed on the INTERFACE MENU. CRESNET ID is the two-digit hexadecimal number. The hexadecimal number can range from 03 to FE and must correspond to the Net ID set in the SIMPL Windows program of the Cresnet system. Matching IDs between touchpanel and SIMPL Windows program is required if data is to be successfully transferred. The Net ID for the TPS-4500V/LV is factory set to 03, and no two devices in the same system can have the same ID.

Two buttons adjacent to the hexadecimal display, **UP** and **DOWN**, increase and decrease the CRESNET ID by one, respectively.

The touchpanel usually communicates with a Cresnet system. Occasionally the touchpanel can be used in a demo mode where it merely displays various menus, but does not communicate with a Cresnet system. In demo mode, the directory buttons change pages, but buttons requiring feedback do not work. Two side-by-side buttons to the right of the CRESNET ID, **Enable CRESNET II** and **Disable CRESNET II**, determine communication mode. Select **Enable CRESNET II** for normal Cresnet communication mode and **Disable CRESNET II** to set the touchpanel into demo mode. Text within the selected button changes color from black to red. Communication mode is factory set to **Enable CRESNET II**.

It is possible to maintain touchpanel control (with the **Enable Touch Screen** button) while communicating via RS-232 with the console or non-Crestron device. Otherwise, choose **Disable Touch Screen** to discontinue touchpanel control. Text within the selected button changes color from black to red.

The TPS-4500V is capable of wireless communication with a control system when equipped with the optional TPS-XTXRF Two-Way RF Transceiver Module and TPS-RFGWX Two-Way RF Transceiver. Choosing **Enable RF** (found on TPS-4500V when equipped with the TPS-XTXRF) enables the RF mode. For more information on configuring a touchpanel with an RF interface, refer to the latest revision of the TPS-XTXRF Two-Way RF Transceiver Module Operations and Installation Guide (Doc. 5844).

NOTE: If the TPS-4500V is to be used without an RF connection, the **RF Disabled** button must be selected.

NOTE: If RF is enabled, the RS-232 communication settings cannot be adjusted. Additionally, when RF is enabled, touchpanel projects cannot be downloaded via RS-232. They can only be downloaded through Cresnet.

Select the **Return** button located on the INTERFACE MENU to accept the changes and return to the SETUP MENU.

RS-232 Menu

RS-232 MENU

BAUDRATE		
110	150	300
600	1200	2400
4800	9600	19200
38400	57600	115200

DATA BITS	
7	8

PARITY		
None	Odd	Even

STOP BITS	
1	2

RS-232 Port for Console
 RS-232 Port for Control
 RS-232 Port for Touch Output
 RS-232 Port for Mouse Input
 RS-232 Port for Ext. Touch Input

RTS-CTS On RTS-CTS Off
 XON-XOFF On XON-XOFF Off

Save and Return

The touchpanel allows for five RS-232 communication methods:

- Console (i.e. loading programs)
- Control (i.e. non-Crestron device): For communicating to third-party devices not controlled by a Crestron control system.
- Touch output (communication of touch coordinates to an external device)
- Mouse input (allows a mouse to control an external device as a “touch the PC” device)
- External touch screen input.

Touch the communication option to select communication parameters and then select **Save and Return** to save the RS-232 settings and return to the SETUP MENU. For instructions on selecting the communication method, refer to “Appendix C: Configuring the RS-232 Port for Use” on page 45.

Video Menu

The TPS-4500V/LV can display a single video source connected to either the 6-pin connector or the BNC connectors of the TPS-4500LV or the TPS-4500IMPC.

Video Setup (Horizontal Lines Portray Video Sample)

	< BRT > 99%
	< CONT > 99%
	< SAT > 99%
	< HUE > 99%
	Fast Motion
	Still Video
	Soft
	Sharp
Default Values	<div style="border: 1px solid black; padding: 2px;">TP AutoDetect</div> <div style="border: 1px solid black; padding: 2px;">TP Composite</div> <div style="border: 1px solid black; padding: 2px;">TP S-Video</div>
	<div style="border: 1px solid black; padding: 2px;">BNC AutoDetect</div> <div style="border: 1px solid black; padding: 2px;">BNC Composite</div> <div style="border: 1px solid black; padding: 2px;">BNC S-Video</div>
	Return

Use this screen to select one of the video inputs and adjust the brightness, contrast, saturation, and hue, if necessary. The user has the option to force the video image to a certain mode (i.e., composite video or S-video) or switch modes automatically after checking the image for colors. Use either the **TP Composite / BNC Composite** or **TP S-Video / BNC S-Video** buttons to manually control the mode. **TP** or **BNC** on the selected button specifies the video input connector. **TP** corresponds to the twisted pair connector (balanced video from a PVID, Room Box, etc.) and **BNC** corresponds to the BNC connectors (unbalanced video from a VCR, DVD, etc.). Use the appropriate **Auto Detect** button for automatic control. The text color of the selected button is red rather than black.

NOTE: The video signal type can be automatically detected as long as one signal is sent to the touchpanel.

NOTE: When using the TPS-4500IMPC with the TPS-4500V, the appropriate inputs must be selected. Refer to the latest revision of the TPS-4500IMPC Interface Module Operations Guide (Doc. 6163, included with the TPS-4500V touchpanel) for details.

NOTE: A solid blue screen is displayed in the video window if a video signal is not detected or is very weak. Verify that the video source is functioning and properly connected. If the source is properly connected and functioning, a distribution amplifier may need to be used.

Fast motion mode (if the **Fast Motion** button is selected) reduces motion artifacts and should be used for most video sources. Still video mode (if the **Still Video** button is selected) works best for still pictures. It has a maximum resolution and reduces flicker. However, it suffers from motion artifacts. The text color of the selected button is red rather than black.

Select the **Soft** button for soft mode video. In this mode, video filtering and noise reduction can produce a better image from some sources. Alternatively, select the **Sharp** button for sharp mode video. This mode provides maximum detail, but is more susceptible to noise in source. The text color of the selected button is red rather than black.

Select the **Return** button, located at the lower right corner of the Video Menu, after video parameters have been set.

Diagnostics Menu

DIAGNOSTICS MENU

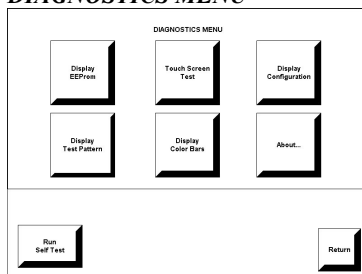

The **Diagnostics** button from the MAIN MENU contains diagnostic tools. The diagnostic tools should only be used under supervision from a Crestron customer service representative during telephone support. The options available from the DIAGNOSTICS MENU, shown to the left, are numeric in nature and their interpretation is beyond the scope of this manual.

NOTE: The “About...” button will display a screen indicating the current version of firmware residing on the touchpanel.

Hardware Hookup

Make the necessary connections as called out in the following illustrations. Refer to “Network Wiring” on page 9 before attaching the NET or NET/VIDEO connector. Apply power after all connections have been made.

CAUTION: Do not apply excessive pressure to the touchscreen display during handling (mounting/installation). Doing so can crack the screen and damage the touchpanel.

TPS-4500LV

Hardware Connections for the TPS-4500LV (Back of the Unit is Shown)

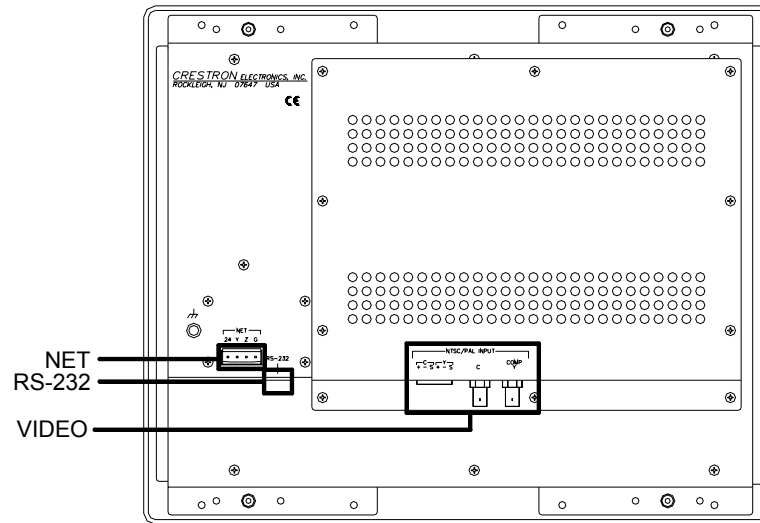

NET

This 4-pin Cresnet connector provides Cresnet network connection from the touchpanel as well as power to the touchpanel. A description of the pinouts is shown in the table after this paragraph. Refer to “Network Wiring” on page 9 for details.

NET Pinouts

PIN #	DESIGNATION	DESCRIPTION
1	24	Power
2	Y	Data
3	Z	Data
4	G	Ground

RS-232

This 6-pin RJ-11 connector mates with a serial port of a PC. The connecting cable is not supplied. Prior to installation, use this port for direct connection between the touchpanel and a PC to load files to a touchpanel without a network connection. In the event that modular cables or an RJ-11 to DB9F adapter is not available, the following table and diagram provide information so that the cable can be fabricated on site. Refer to “RS-232 Menu” on page 13 for proper RS-232 port configuration settings. Refer to “Appendix A: RS-232 Protocol” on page 42 for protocol details.

RS-232 Pinouts

PIN #	DESCRIPTION
1	CTS
2	GND
3	RXD
4	TXD
5	RTS
6	N/C (Not connected)

PC to TPS-4500V/LV Cable Specifications (Crestron Cable Number STCP-502PC)

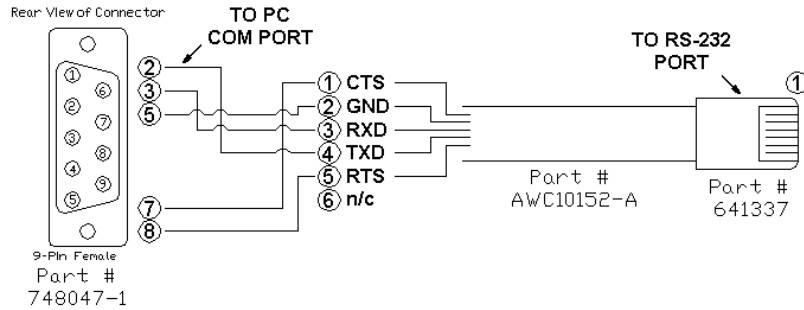

Video

Three connectors are provided for supplying a composite or S-video signal to the TPS-4500LV. The TPS-4500LV can accept balanced video signals using CAT5 wiring or unbalanced signals using the BNC connectors. Refer to the following diagram to make video connections to the TPS-4500LV.

Video Connections

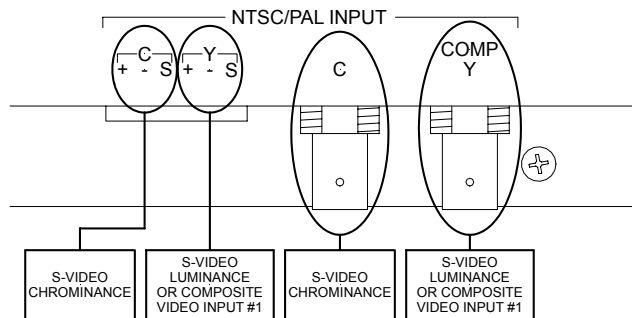

NOTE: For additional information on video connections over CAT5, refer to the latest version of the Crestron CAT5 Wiring Reference Guide (Doc. 6137) which is available from the Downloads | Product Manuals section of the Crestron website (www.crestron.com).

After connecting the video cables to a specific connector, the video input must be set in the Video Menu. Refer to “Video Menu” on page 13 for more information.

TPS-4500V

Hardware Connections for the TPS-4500V (Back of the Unit is Shown)

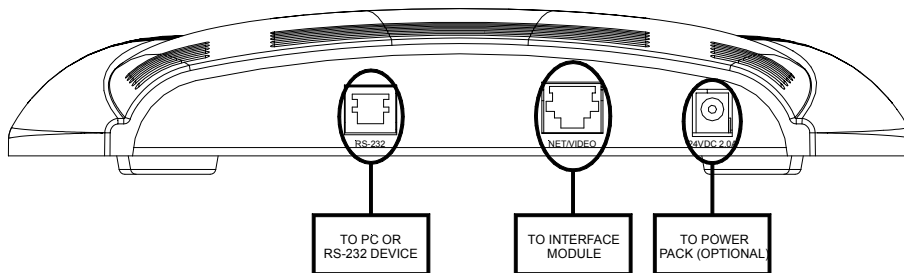

RS-232

This 6-pin RJ-11 connector mates with a serial port of a PC. The connecting cable is not supplied. Prior to installation, use this port for direct connection between the touchpanel and a PC to load files to a touchpanel without a network connection. In the event that modular cables or an RJ-11 to DB9F adapter is not available, the following table and diagram provide information so that the cable can be fabricated on site. Refer to “RS-232 Menu” on page 13 for proper RS-232 port configuration settings. Refer to “Appendix A: RS-232 Protocol” on page 42 for protocol details.

RS-232 Pinouts

PIN #	DESCRIPTION	
1	CTS	
2	GND	
3	RXD	
4	TXD	
5	RTS	
6	N/C (Not connected)	

PC to TPS-4500V/LV Cable Specifications (Crestron Cable Number STCP-502PC)

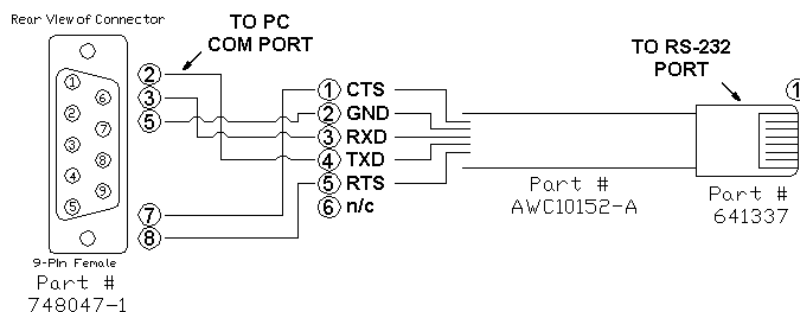

NET/VIDEO

This 10-pin RJ-45 connector mates with the TPS-4500IMPC or TPS-IMW interface module and has a dual purpose.

CAUTION: The 10-pin RJ-45 connector cable supplied by Crestron is a custom cable and is the only one that should be used. The end of the cable has a metal shield

that is required to protect the equipment. Using non-Crestron cables will result in damage to the product.

This 10-pin RJ-45 port provides network connection from the touchpanel to the interface module and network power to the touchpanel. This port also contains the composite and S-video connections for supplying video signals to the touchpanel from the interface module. Refer to the descriptions and pinout table that follow this paragraph.

Pin Assignments

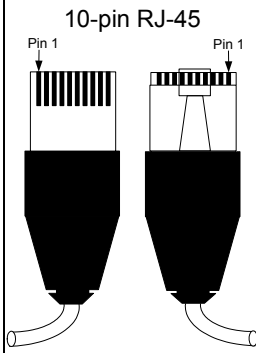
TYPE	PIN	DESIGNATION	DESCRIPTION
10-pin RJ-45 	1	+24V	Power (Network)
	2	GND	Ground (Network)
	3	C+	Chrominance (Positive) /Composite 2
	4	C-	Chrominance (Negative) /Composite 2
	5	Y	Data (Network)
	6	Z	Data (Network)
	7	Y+	Luminance (Positive)/Composite 1
	8	Y-	Luminance (Negative)/Composite 1
	9	GND	Ground (Network)
	10	+24V	Power (Network)

To determine the location of pin 1, hold the cable so that the end of the 10-pin RJ-45 connector is facing away from you, with the clip side down and the copper side up. The copper connector on the far left is pin 1.

24 VDC, 2.0A (Power Supply for TPS-4500V)

This female connector is used to supply 24 VDC power to the TPS-4500V or the TPS-4500IMPC from an optional power pack (Crestron model PW-2420RU). When power is supplied to the TPS-4500IMPC through this connector, a Cresnet power connection is not required to display video on the touchpanel.

CAUTION: Use only Crestron power supplies for Crestron equipment. Failure to do so could cause equipment damage or void the Crestron warranty.

CAUTION: If power is provided to the TPS-4500V from the +24VDC on a Cresnet connector or the optional PW-2420RU to the touchpanel base, power must not be applied to the power input on the TPS-4500IMPC.

NOTE: Use care in wiring installations to avoid applying 24 VDC power to Cresnet wiring from multiple sources.

Video

Composite or S-video signals are supplied to the TPS-4500V via the TPS-4500IMPC. The TPS-4500IMPC can accept balanced video signals using CAT5 wiring or unbalanced signals using the BNC connectors. Refer to the following diagram to make video connections to the TPS-4500IMPC.

Video Connections

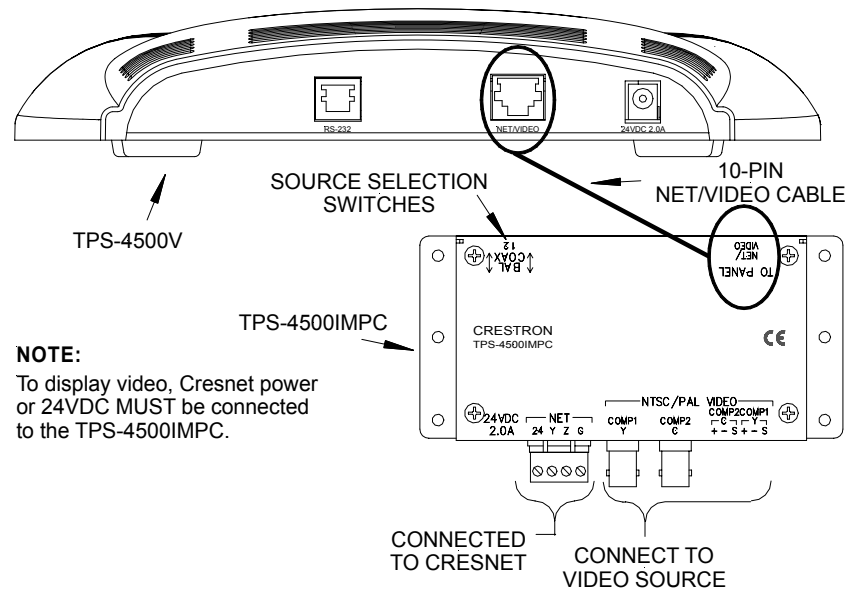

NOTE:
To display video, Cresnet power or 24VDC MUST be connected to the TPS-4500IMPC.

NOTE: The source selection switches must be set to “BAL” if CAT5 wiring is used or “COAX” if the BNC connectors are used.

NOTE: For additional information on video connections over CAT5, refer to the latest version of the Crestron CAT5 Wiring Reference Guide (Doc. 6137) which is available from the Downloads | Product Manuals section of the Crestron website (www.crestron.com).

After connecting the video cables to the proper connector, the appropriate source selection switches must be set and the video input must be set in the Video Menu. Refer to the latest revision of the TPS-4500IMPC Interface Module Operations Guide (Doc. 6163, included with the TPS-4500V touchpanel) and “Video Menu” on page 13 for more information.

Touchpanel Mounting Options for TPS-4500LV

Back Box Mounting

Back box mounting is typically used at new construction sites. The optional back box, BB-5000, includes the necessary hardware, brackets and electrical box, which provides a secure enclosure that can be fastened directly to a stud. The details for this optional mounting method are provided in the latest revision of the BB-5000 Installation Guide (Doc. 5827). After completing the steps in the installation guide, simply mate the four posts of the bezel with the holes drilled into the mounting surface and firmly press the bezel over the touchpanel.

NOTE: The mounting hardware and accessories supplied with the TPS-4500LV are not required for the back box mounting option.

Direct Mounting

The TPS-4500LV is a low-voltage unit that can be installed directly into a mounting surface. Each touchpanel is provided with mounting hardware and accessories, as shown in the table after this paragraph.

TPS-4500LV Supplied Mounting Hardware and Accessories

ITEM	PART NUMBER	QUANTITY
Large Metal Mounting Plate	MTPL02553-1	2
Small Metal Mounting Plate	MTPL02523-1	2
Template	OV40049-1	1
Screw, Pan Phillips	#6-32 x 1" LG	12
Connector	JHPS197SG04SR-2	1
Connector	JHPS138SG06SR-2	1

NOTE: For cutout dimensions, refer to “Appendix B: Cutout Detail of Supplied Template” on page 44.

Complete the following installation procedure in the order provided. The only tools required are a gypsum board saw (or equivalent), a #2 Phillips tip screwdriver, a drill, a 5/16" bit, and a #20 bit. Complete the following installation procedure in the order provided.

1. Locate an area on the wall that is free of miscellaneous wiring and studs.
2. Make a small hole near the middle of the designated site; verify that the location is suitable.
3. Fasten cutout template (40049, supplied) to mounting surface; verify that the template is level.
4. Cut out and remove the traced shape of the mounting surface.
5. Drill four 5/16" holes as marked on template. Refer to “Appendix B: Cutout Detail of Supplied Template” on page 44 for an illustrative reference.
6. Drill 12 holes marked “A” on template with #20 bit. Refer to “Appendix B: Cutout Detail of Supplied Template” on page 44 for an illustrative reference.
7. Slide one large metal mounting plate through the opening and position it inside along the top horizontal edge.
8. Position one small metal mounting plate along the top horizontal edge so that it covers the two center holes marked “A”.
9. Use two pan head screws, supplied, to secure the bracket and plate to the mounting surface. Tighten by hand; do not fully tighten screws.

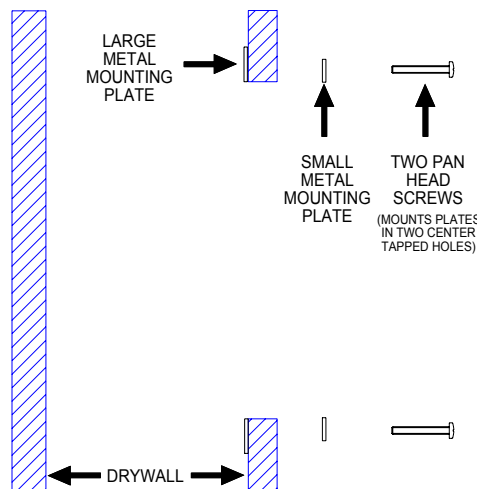
Securing Two Plates to Top and Bottom Edges of Opening

10. Repeat steps 7 through 9 for the bottom horizontal edge of the opening.
11. Attach the network cable and other cables (i.e., RS-232 or video) in the wall to the appropriate connector on the back of the touchpanel. Refer to “Network Wiring” on page 9 for network wiring details. Information about the RS-232 connector is located in “RS-232” on page 15. For wiring the video connector, refer to “Video” on page 16.
12. Position the touchpanel (less the faceplate) into the opening and secure with eight pan head screws, supplied. Tighten by hand; do not fully tighten screws.

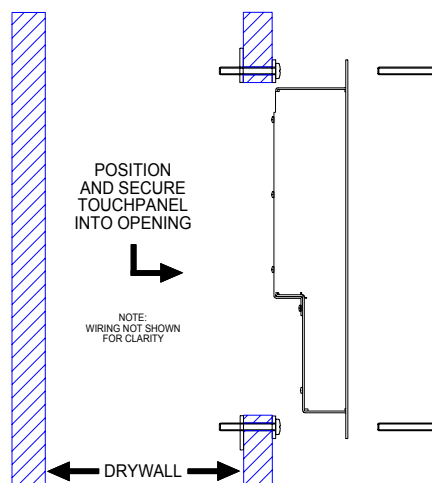
Positioning Touchpanel into Opening

13. Use the #2 Phillips screwdriver and fully tighten all 12 pan head screws. Use caution and do not crack or damage mounting surface.
14. Mate the four posts of the bezel with the holes drilled into the mounting surface and firmly press on the bezel over the touchpanel.

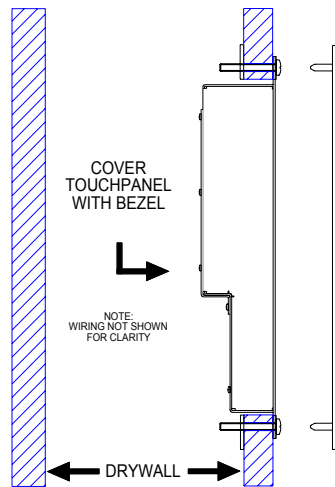
Cover Touchpanel with Bezel**Touchpanel Removal (TPS-4500LV)**

If it is necessary to remove the TPS-4500LV after it has been installed into a mounting surface, complete the following steps in the order provided to remove the touchpanel. The only tool required is a #2 Phillips tip screwdriver.

1. Lift the plastic cover off the touchpanel. Do not apply excessive pressure to the touchscreen.
2. Loosen and remove the screws that secure touchpanel to the mounting option in use.
3. Using equal pressure, carefully remove the touchpanel from the opening.
4. If necessary, secure and label the attached cables before disconnecting them from the back of the touchpanel.

Recommended Cleaning

Keep the surface of the touchscreen free of dirt, dust, or other materials that could degrade optical properties. Long-term contact with abrasive materials can scratch the surface, which may degrade image quality.

For best cleaning results, use a clean, damp, non-abrasive cloth with any commercially available non-ammonia glass cleaner. The faceplate may not provide a complete watertight seal. Therefore, apply cleaning solution to the cloth rather than the surface of the touchscreen. Wipe touchscreen clean and avoid ingress of moisture beneath panels.

Programming Software

*Have a comment about
Crestron software?*

*Direct software related suggestions
and/or complaints to Crestron via
email (software@crestron.com).
Do not forward any queries to this
address. Instead refer to "Further
Inquiries" on page 41 for assistance.*

Setup is easy thanks to Crestron's Windows®-based programming software. Crestron Application Builder™ (AppBuilder) creates a complete project, with no special programming required. Crestron AppBuilder completes all necessary programming for a base system including all touchpanel screens and the control system program. Once Crestron AppBuilder creates the project, the system interfaces and program logic can be customized. It can easily be modified with Crestron development tools (i.e., SIMPL Windows and Crestron VisionTools® Pro-e (VT Pro-e) software packages).

The program output of Crestron AppBuilder is a SIMPL Windows program with much of the functionality encapsulated in macros. Therefore, extending the capabilities of the system is very easy. Crestron AppBuilder and SIMPL Windows are intended for users with different levels of programming knowledge. Crestron AppBuilder is easier to use for the beginning programmer, and much faster for all programmers. However, it does not allow the degree of control and flexibility that SIMPL Windows does. Of course, one can initiate programming using the easiest method (Crestron AppBuilder) and use advanced techniques that are available from SIMPL Windows to customize the job.

Crestron AppBuilder comes with templates for all supported interfaces. If a user wishes to create a touchpanel project using templates with a different look-and-feel this can be accomplished by making a custom template. This custom template can then be used by Crestron AppBuilder to create the final project files to be loaded into the panels. Alternatively, VT Pro-e can be used to tweak projects created with Crestron AppBuilder or develop original touchpanel screen designs.

VT Pro-e is used to create interactive touchpanel screen designs to access functions of the control system program. When using VT Pro-e version 3.1.2.0 or later, a programmer can take advantage of Crestron's Synapse™ graphics and multi-byte international character support.

The following are recommended software version requirements for the PC:

- Application Builder version 1.1.6 or later with Application Builder Templates version 2.12 or later. Requires SIMPL Windows.
- SIMPL Windows version 1.50.05 or later with library update file. Requires SIMPL+ Cross Compiler version 1.1.
- Crestron Database version 14.1 or later. Required by SIMPL Windows.
- VisionTools Pro-e version 2.2.0.0 or later. Used for graphical touchscreen design. To use Synapse graphics and multi-byte international characters in a touchpanel screen, VT Pro-e version 3.1.2.0 or later is required. Touchpanel firmware version 2.000.0 or later is also required.

NOTE: The latest versions can be obtained from the Downloads | Software Updates section of the Crestron website (www.crestron.com). Crestron software and any files on the website are for Authorized Crestron dealers and Crestron Authorized Independent Programmers (CAIP) only. New users may be required to register to obtain access to certain areas of the site (including the FTP site).

Digital, analog, and serial join numbers are a common thread between VT Pro-e and SIMPL Windows. These numbers define how the objects on a touchpanel page of a VT Pro-e project interface to the outside world, specifically the Cresnet system as defined in the SIMPL Windows program. There are digital join numbers that carry out some predetermined function (a logical high or low); analog join numbers for

displaying incremental values, sliders, gauges and bar graphs; and serial join numbers that allow for the display of variable text and transmission/reception of serial commands from other manufacturers. Unjoined objects are not interfaced with the system and thus cannot initiate any logic functions (although they can perform page flips).

The easiest method of programming, but does not offer as much flexibility as SIMPL Windows.

Programming with the Crestron AppBuilder

Crestron AppBuilder offers automatic programming for such residential and commercial applications as audio distribution, home theater, video conferencing, and lighting. The interface of this tool guides you through a few basic steps for designating rooms and specifying the control system, touchpanels, devices, and functionality. Crestron AppBuilder then programs the system, including touchpanel projects and control system logic.

Crestron AppBuilder is fully integrated with Crestron's suite of software development tools, including SIMPL Windows, VT Pro-e, and the Crestron Database. Crestron AppBuilder accesses these tools behind the scenes, enabling you to easily create robust systems.

Programming with SIMPL Windows

NOTE: The following assumes that the reader has knowledge of SIMPL Windows. If not, refer to the extensive help information provided with the software.

NOTE: The following are acceptable file extensions for programs that include a TPS-4500V/LV, developed for specific control system types:

- .smw: *projectname.smw* (SIMPL Windows source file)
- .spz: *projectname.spz* (compiled file for 2-series)
- .bin: *projectname.bin* (compiled file for CNX generation)
- .csz: *projectname.csz* (compiled SIMPL+ file for CNX generation)
- .ush: *projectname.ush* (compiled file for CNX generation with SIMPL+ header file)
- .usp: *projectname.usp* (source code module for SIMPL+)
- .umc: *projectname.umc* (*user macro*)

NOTE: In the following description, the PRO2 control system is used.

SIMPL Windows is Crestron's software for programming Crestron control systems. It provides a well-designed graphical environment with a number of workspaces (i.e., windows) in which a programmer can select, configure, program, test, and monitor a Crestron control system. SIMPL Windows offers drag and drop functionality in a familiar Windows® environment.

This section describes a sample SIMPL Windows program that includes a TPS-4500V/LV touchpanel. A Join Number Remapping (JNR) program can be written to augment the functionality of the touchpanel by making some of the touchpanel's internal functions available to the SIMPL Windows programmer. Refer to "Join Number Remapping" on page 28 for more information.

Configuration Manager is where programmers "build" a Crestron control system by selecting hardware from the *Device Library*. In Configuration Manager, drag the PRO2 from the Control Systems folder of the *Device Library* and drop it in the upper pane of the *System Views*. The PRO2 with its associated communication ports is displayed in the *System Views* upper pane.

PRO2 System View

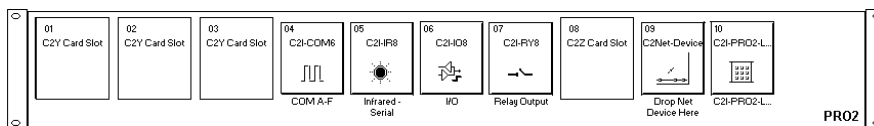

The *System Views* lower pane displays the PRO2 system tree. This tree can be expanded to display and configure the communications ports.

Expanded PRO2 System Tree

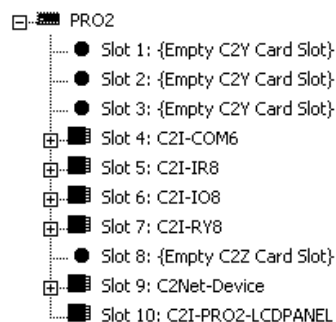

C2Net-Device Slot in Configuration Manager

To incorporate the TPS-4500V/LV touchpanel into the system, drag the TPS-4500 from the Touchpanels | Touchpanels (Cresnet) folder of the *Device Library* and drop it in the *System Views*. The PRO2 system tree displays the touchpanel in slot 9 with a default Net ID of 03 as shown in the following illustration.

NOTE: The first touchpanel in a system is preset with a Net ID of 03, when its symbol is dragged into the upper pane of *System Views*. Additional touchpanels are assigned different Net ID numbers as they are added.

C2Net Device, Slot 9

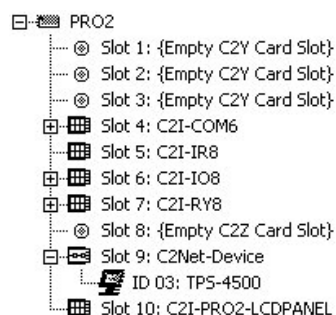

Setting the Net ID in Device Settings

Double-click the TPS-4500 icon to open the “Device Settings” window. This window displays the TPS-4500 device information. If necessary, select the *Net ID* tab to change the Net ID, as shown in the following figure.

“Device Settings” Window for the TPS-4500

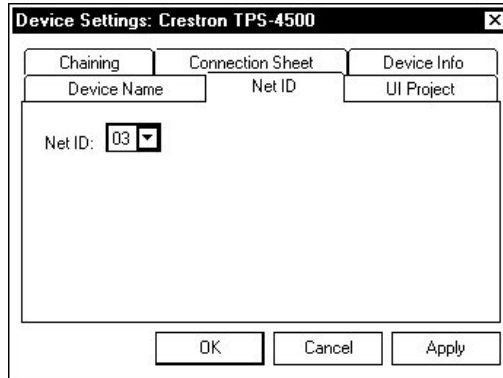

NOTE: SIMPL Windows automatically changes Net ID values of a device added to a program if a duplicate device or a device with the same default Net ID already exists in the program. Always ensure that the hardware and software settings of the Net ID match. For Net ID hardware settings details, refer to “Interface Menu” on page 12.

TPS-4500 Symbol in Programming Manager

Programming Manager is where programmers “program” a Crestron control system by assigning signals to symbols. The following diagram shows the TPS-4500 symbol in the SIMPL Windows’ Programming Manager.

Detail View of the TPS-4500 in SIMPL Windows’ Programming Manager

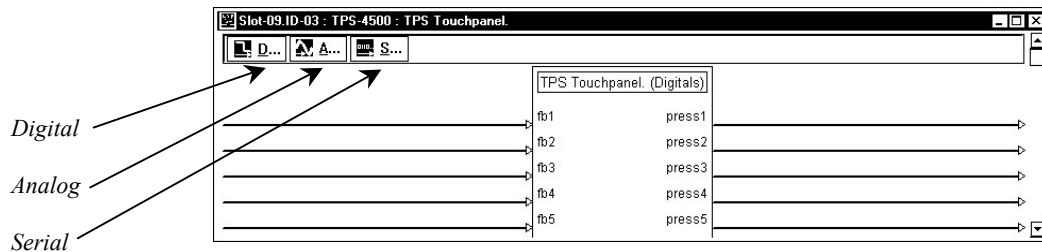

NOTE: Join numbers are expandable to 4000 digital & analog, 999 serial.

Signal Types

Signals interconnect the various devices and logic symbols that comprise a SIMPL program. Signals can be one of three types: digital, analog, or serial. For any given signal, the signal type is determined by its driving source. That is, if the symbol that drives the signal has an analog output, then, by definition, the connecting signal is analog.

In SIMPL Windows, the signal types are color-coded as follows:

- Digital = Blue**
- Analog = Red**
- Serial = Black**
- Undefined/Other = Green**

NOTE: “Other” signals are a combination of the three basic types (e.g. many symbols accept either analog or serial signals; the combination is shown as a green signal). The signal type is displayed on the Status Bar when the signal is highlighted.

For additional information, refer to Doc. 6120, Crestron SIMPL Windows Symbol Guide. It may be downloaded from the Downloads | Product Manuals | Software section of the Crestron website (www.crestron.com).

Digital Signals

A digital signal contains one bit of information and usually takes on one of two values: 1 or 0. These two digits can represent the logical values true and false, and they can be represented in an electronic device by the states on/off or high/low, recognized as two voltage levels. (Other common descriptors are active/inactive.)

Analog Signals

Unlike digital signals, analog signals can vary continuously in value, in the same manner as a parameter such as volume, temperature, or pressure. Analog signals contain 16 bits of information, which means that this type of signal can have values ranging from 0 to 65535 ($2^{16}-1$). This 16-bit property makes analog signals useful for controlling devices that do not have discrete settings, such as volume controllers, pan/tilt head controllers, and lighting dimmers.

Serial Signals

Serial signals are much like analog signals, in that they, too, contain 16 bits of information. However, whereas the value of an analog signal is used directly-to control volume or temperature, for instance—the value of the serial signal is used as a pointer to a location in memory that contains a string of characters. When a serial signal is routed to a symbol, that symbol can identify the signal as serial rather than analog and it will automatically look at the data it points to.

Thus serial signals are used to facilitate the transmission of serial data (strings of characters). These signals can be generated by incoming data on a COM port or by a symbol that has a serial output.

TPS-4500 Input/Output Signals

The TPS-4500 symbol provides up to 4000 digital input and output joins, 4000 analog input and output joins, and up to 999 serial input joins. The programmer selects the signal types by clicking on the appropriate button at the top of the *Symbol Detail* view when programming the panel.

The following tables list and give functional descriptions for the touchpanel outputs and inputs.

Digital Output Signal Descriptions

OUTPUT	DESCRIPTION
press 1 through press 4000	Notifies control system of button press (1 - 4000). High/1 = Button being pressed Low/0 = Button not being pressed

Digital Input Signal Descriptions

INPUT	DESCRIPTION
fb 1 through fb 4000	Notifies panel of button press (1 - 4000). This can represent that the button was pressed, or can be an actual device feedback, e.g., that power was turned on.

Analog Output Signal Descriptions

OUTPUT	DESCRIPTION
an_act 1 through an_act 4000	Notifies control system of an action (1 - 4000). Any value from 0 through 65535

Analog Input Signal Descriptions

INPUT	DESCRIPTION
an_fb 1 through an_fb 4000	Notifies panel of analog action (1 - 4000).

Serial Input Signal Descriptions

INPUT	DESCRIPTION
text-01 through text-999	Notifies panel of text string (1 - 999). Also called indirect text.

Device Extenders

Device extenders provide additional logic and functionality to a device. The Poll Manager and Sleep/Wake Manager symbols are device extenders for touchpanels. Poll Manager takes the touchpanel on and off line during polling by the control system. Sleep/Wake Manager suspends and restores operation of the touchpanel. For additional information about Device Extenders, refer to the latest version of the Crestron SIMPL Windows Symbol Guide (Doc. 6120), or the on-line help included with SIMPL Windows.

Example Program

An example program for the TPS-4500V/LV is available from the Crestron FTP site (<ftp.crestron.com/Examples>). Search for the file TPS-4500_SIMPL_Windows_example_file.smw that contains the example program.

Join Number Remapping

Join Number Remapping (JNR) is a programming concept that allows a TPS Series Panel to use join numbers with values over 4000 (Join Numbers 4001 to 15999 and Reserved Join Numbers) by bringing them within the range of the TPS touchpanel symbol, thereby increasing a touchpanel's functionality. Through JNR, a TPS Series Panel's internal functions become accessible to a control system and can activate the local functions of other touchpanels, route its internal feedback back to the control system, and receive feedback from remote locations. JNR provides the additional capability of managing IP IDs in Ethernet applications where a touchpanel communicates with multiple control systems that have been uploaded with the same program. Refer to the latest version of the Join Number Remapping Reference Guide (Doc. 5969) and the SIMPL Windows help file for more details.

Programming with VisionTools® Pro-e

VT Pro-e, a design and programming Windows®-based software, permits the creation of unlimited control screen variations incorporating two and three-dimensional graphics, video, and text. A set of pages, which make up a project, can

be designed for each TPS-4500V/LV touchpanel application. Each page contains objects such as video windows, custom control graphics, two and three-dimensional buttons, sliders, and digital readouts that allow the user to interface with the control system via join numbers. Unjoined objects are not interfaced with the system and thus cannot initiate any functions. The completed and compiled project is uploaded to the touchpanel and programmed into the flash PROM via the **File | Upload Project** command. The touchpanel uses the programmed project until another project is uploaded from the PC. Programs cannot be extracted from the touchpanel. The PC may be disconnected from the control system or panel except during reprogramming. VT Pro-e also allows users the option to generate projects destined for web browsers rather than for physical touchpanels.

Crestron's Synapse image-rendering algorithm supports advanced anti-aliasing for crisper, sharper images, as well as new shaded styles for all objects, new frame styles (neon and raised), and new text styles (embossed, raised, and shadow). The Synapse algorithm allows the touchpanel to process these styles internally, without the use of large bitmap files that increase project size and upload time. Synapse delivers high impact touchpanel graphics more efficiently than ever. To utilize Synapse graphics, you must use VT Pro-e version 3.1.2.0 or later and Isys touchpanel firmware 2.000.0 or later.

NOTE: The following are acceptable file extensions for programs that include a TPS-4500V/LV:

.vtp *projectname.vtp* (VT Pro-e source file)
.vtz *projectname.vtz* (compiled file)

Creating a Video Window

A video window object must reside on a page within the uploaded VT Pro-e touchpanel project for video signals to be displayed.

The video window object properties must have the video source specified in the *Input number* field of the *Source* tab. Select **Composite 1** as shown in the following illustration and click **OK**.

Selecting the Video Source

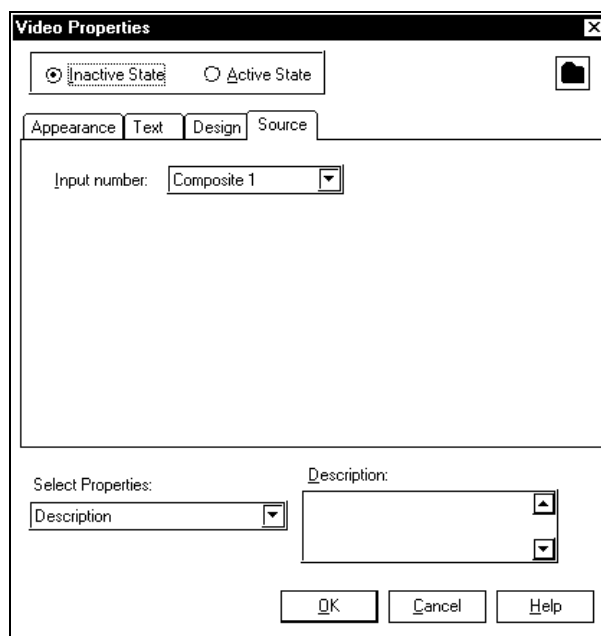

For additional software information, refer to the help file provided with the software. The latest version of VT Pro-e can be obtained from the Downloads | Software Updates section of the Crestron website (www.crestron.com).

Multi-Mode Objects

Multi-mode objects offer high-performance programming!

The single most-advanced VT Pro-e high-performance programming technique involving the TPS-4500V/LV is the concept of multi-mode objects. A multi-mode object (i.e., button, legend, etc.) is an object drawn on a VT Pro-e page that can have one or more active and inactive visible settings (*modes*).

For examples, refer to the MULTI-MODE_OBJECT_EXAMPLES_OF_VTPRO-E_PROJECTS_USE_WITH_ISYS_TOUCHPANELS.ZIP file. It is available from the Crestron FTP site ([ftp.crestron.com/Examples](ftp://ftp.crestron.com/Examples)). This file contains the VT Pro-e touchpanel files and SIMPL Windows files that illustrate the high-performance capabilities of multi-mode objects.

Reserved Join Numbers

A reserved join number is a feature of the software that enables a designer to create a button that completes a predetermined function. The tables on the next few pages provide lists of reserved join numbers available within the software.

NOTE: Many touchpanel configuration “shortcuts” are available via the software. A button can be created on a page that either calls up the Preferences Menu, adjusts brightness, etc., via reserved join numbers.

NOTE: Reserved join numbers can also be automatically activated by a control system when using join number remapping. Refer to the latest version of the Join Number Remapping Reference Guide (Doc. 5969) which can be found on the Downloads | Product Manuals section of the Crestron website (www.crestron.com), and the SIMPL Windows help file for more details.

Video Analog Reserved Join Numbers for the TPS-4500V/LV Touchpanels

JOIN #	FUNCTION	VALUE	IN/OUT
17100	Video	Brightness	INPUT/OUTPUT
17101	Video	Contrast	INPUT/OUTPUT
17102	Video	Saturation	INPUT/OUTPUT
17103	Video	Hue	INPUT/OUTPUT

Video Digital Reserved Join Numbers for TPS-4500V/LV Touchpanels

JOIN #	FUNCTION	VALUE	IN/OUT
17101	Video	Video Composite TP	INPUT
17102	Video	S-video TP	INPUT
17103	Video	Auto Detect TP	INPUT
17104	Video	Video Composite BNC	INPUT
17105	Video	S-video BNC	INPUT
17106	Video	Auto Detect BNC	INPUT
17107	Video	Still	INPUT

(continued on next page)

Video Digital Reserved Join Numbers for TPS-4500V/LV Touchpanels (continued)

JOIN #	FUNCTION	VALUE	IN/OUT
17108	Video	Motion	INPUT
17109	Video	Sharp	INPUT
17110	Video	Soft	INPUT
17111	Video Brightness	Increase	INPUT
17112	Video Brightness	Decrease	INPUT
17113	Video Contrast	Increase	INPUT
17114	Video Contrast	Decrease	INPUT
17115	Video Saturation	Increase	INPUT
17116	Video Saturation	Decrease	INPUT
17117	Video Hue	Increase	INPUT
17118	Video Hue	Decrease	INPUT
17119	Video	No Input Flag	INPUT
17120	Video	AGC On	INPUT
17121	Video	AGC Off	INPUT
17122	Video	Defaults*	INPUT

* Video default is 50% for each of the video parameters (brightness, contrast, saturation, and hue)

System Analog Reserved Join Numbers for TPS-4500V/LV Touchpanels

JOIN #	FUNCTION	VALUE	IN/OUT
17200	Cresnet ID Setting	Cresnet ID	INPUT/OUTPUT
17201	Brightness	LCD Brightness	INPUT/OUTPUT
17202	Power Down Timeout	Power Down	INPUT/OUTPUT
17203	System Standby	Time Out	INPUT/OUTPUT

System Digital Reserved Join Numbers for TPS-4500V/LV Touchpanels

JOIN #	FUNCTION	VALUE	IN/OUT
17200	System Off	N/A	INPUT
17214	Cresnet ID	Down	INPUT
17215	Cresnet ID	Up	INPUT
17216	Brightness	Increase	INPUT
17217	Brightness	Decrease	INPUT
17218	Brightness	High	INPUT
17219	Brightness	Medium	INPUT
17220	Brightness	Low	INPUT
17231	Standby Timeout	Up	INPUT
17232	Standby Timeout	Down	INPUT
17233	Power Down Timeout	Up	Input
17234	Power Down Timeout	Down	Input
17242	Call up Setup Menu	N/A	INPUT

MultiByte International Characters

Most languages use a single byte of 8 bits to represent a character, e.g. English, French, German, Hebrew, Russian, Thai, etc.

Multibyte character fonts require more than the usual 8 bits to specify a character. This occurs when a language has more than 256 characters (2^8) in a font. For example, Chinese fonts contain several thousand characters. Other multibyte languages include Japanese and Korean.

There are two separate issues with multibyte characters: static text on buttons and indirect text on buttons. No Isys touchpanel firmware changes are required in either case.

Static text on a button, entered in the standard way in VT Pro-e, always works under Windows 98. Under Windows XP, you must use VT Pro-e 3.0 or later.

Indirect text on a button is entered in VT Pro-e and the actual string to be displayed is entered in SIMPL Windows. You must use VT Pro-e 3.0 or later to guarantee that the full set of characters in the font is stored on the touchpanel. You must use SIMPL Windows 2.03.11 or later to enter Chinese characters directly. As of this publication date, only completely single byte or completely multibyte strings may be entered or they will not be compiled correctly in SIMPL Windows. In other words, you cannot enter Chinese character interspersed with numbers. You can enter Chinese characters or numbers in separate strings. Crestron is scheduling time to fix this in the near future and the release notes for SIMPL Windows will mention it.

For now, the workaround of showing a graphic that displays the string can be used, but it is not dynamic.

Uploading and Upgrading

Assuming a PC is properly connected to the entire system, Crestron programming software allows the programmer to upload programs and projects to the system and touchpanel after their development. However, there are times when the files for the program and projects are compiled and not uploaded. Instead, compiled files may be distributed from programmers to installers, from Crestron to dealers, etc. Even firmware upgrades are available from the Crestron website as new features are developed after product releases. In those instances, one has the option to upload via the programming software or to upload and upgrade via the Crestron Viewport.

NOTE: The Crestron Viewport is available as a pull-down command from SIMPL Windows and VT Pro-e (**Tools | Viewport**) or as a standalone utility. The Viewport utility performs multiple system tasks, primarily via an RS-232 or TCP/IP connection between the control system and a PC. It is used to observe system processes, upload new operating systems and firmware, change system and network parameters, and communicate with network device consoles and touchpanels, among many other tasks. Viewport can also function as a terminal emulator for generic file transfer. All of these functions are accessed through the commands and options in the Viewport menus. Therefore, for its effectiveness as a support and diagnostic tool, the Crestron Viewport may be preferred over development tools when uploading programs and projects.

The following sections define how one would upload a SIMPL Windows program, VT Pro-e project or upgrade the firmware of the TPS-4500V/LV touchpanel. However, before attempting to upload or upgrade, it is necessary to establish communications.

Communication Settings

Connection of a PC to the TPS-4500V/LV touchpanel can be direct via the RS-232 port on the touchpanel or through a control system (Cresnet). Both methods of connection provide setup for RS-232 communication.

NOTE: For laptops and other PCs without a built-in RS-232 port, Crestron recommends the use of PCMCIA cards, rather than USB-to-serial adapters. If a USB-to-serial adapter must be used, Crestron has tested the following devices with good results:

- Belkin (large model) F5U103
- I/O Gear GUC232A
- Keyspan USA-19QW

Other models, even from the same manufacturer, may not yield the same results.

To prepare the TPS-4500V/LV for uploading or upgrading, refer to the following figure for a typical connection diagram.

Typical Connection Diagram when Uploading a Project

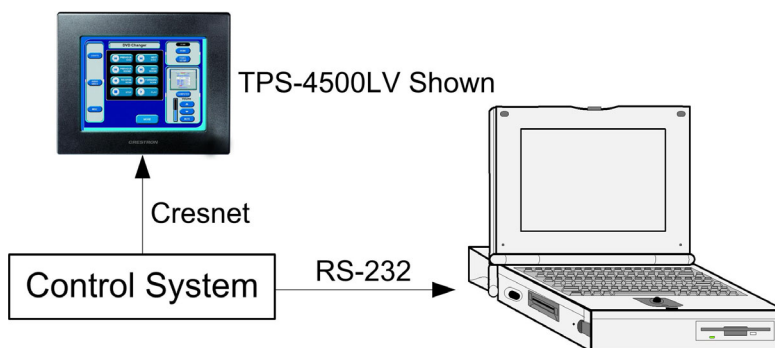

To prepare the TPS-4500V/LV for uploading or upgrading directly from a PC, refer to the following figure. Connect the RS-232 port of the computer directly to the RS-232 port of the touchpanel. Refer to page 15 for RS-232 cable information.

NOTE: Directly connecting to the touchpanel over RS-232 provides a faster transmission speed than Cresnet.

Typical Connection Diagram when Uploading a Project Directly to the Touchpanel

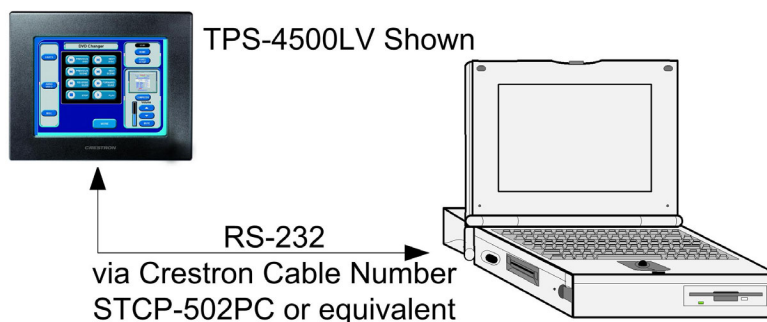

NOTE: For cable pinouts, refer to “RS-232” on page 15.

1. Open the Crestron Viewport.
Either launch the stand-alone version of Viewport, or start SIMPL Windows, and from the menu bar, select **Tools | Viewport**.
2. Refer to the following figure. From the Viewport menu, select **Setup | Communications settings** (alternatively, press **Alt+D**) to open the “Port Settings” window.

Setup | Communications Settings Command

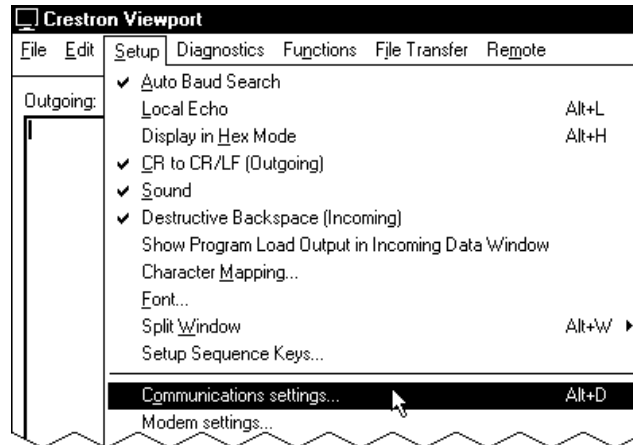

3. Select **RS-232** as the connection type. Verify that an available COM port (COM 1 is shown after this step) is selected, and that all communication parameters and necessary options from the “Port Settings” window are selected as shown after this step. Click the **OK** button to save the settings and close the window.

“Port Settings” Window

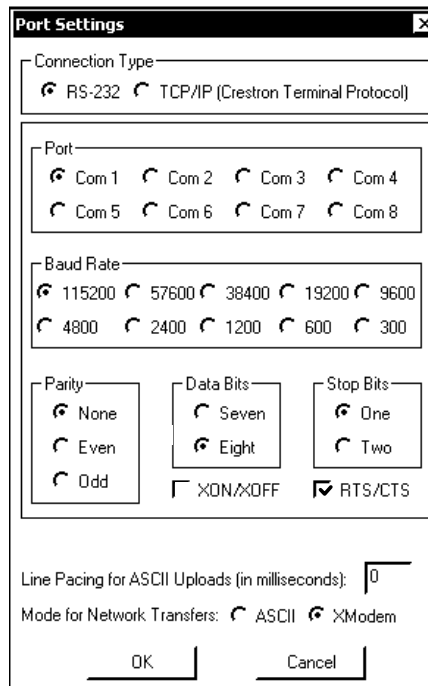

NOTE: The parameters shown in the previous illustration are the port settings for a 2-Series control system. Consult the Operations Guide for the control system being used for exact parameter selection.

NOTE: If connecting to the touchpanel through a control system, the baud rate may need to be set to 38400 baud (Cresnet speed) for a successful transfer.

- To verify communication, select **Diagnostics | Establish Communications (Find Rack)**. This should display a window that gives the COM port and baud rate. If communication cannot be established, refer to the “Troubleshooting Communications” section in the respective Operations Guide for the control system.

Uploading a SIMPL Windows Program

The SIMPL Windows file can be uploaded to the control using SIMPL Windows or via the Crestron Viewport.

A control system source file has the extension .smw. A compiled SIMPL Windows file has the extension .spz for a 2-Series control system, .bin for CNX generation, and .csz for CNX generation with SIMPL+.

Upload via SIMPL Windows

- Start SIMPL Windows.
- Select **File | Open** to view the “Open” window, navigate to the SIMPL Window file (.smw), and click **Open**.
- Select **Project | Transfer Program**.

Upload via Crestron Viewport

- Verify that the procedure for “Communication Settings” that begins on page 33 has been performed.
- As shown after this step, select **File Transfer | Send Program** (alternatively, press **Alt+P**) from the Viewport menu.

File Transfer | Send Program Command

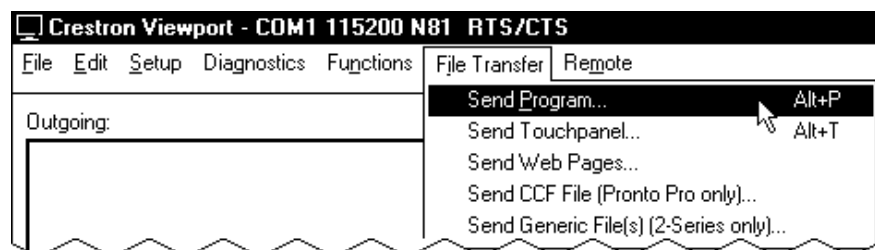

- The “Send Program” window appears, as shown after this step. Click **Browse**, locate the compiled file (.spz) and click **Open**. This will display the program’s header information and enable one or both of the *What to Send* check boxes. If the program does not contain any SIMPL+ modules, only the *SIMPL Program* check box will be enabled. If it does contain SIMPL+ modules, then the *SIMPL+Program(s)* check box will also be enabled. Select one or both check boxes and then click **Send Program** to begin the transfer.

NOTE: Refer to the respective Operations Guide for the control system for details about the other fields shown on the “Send Program” window.

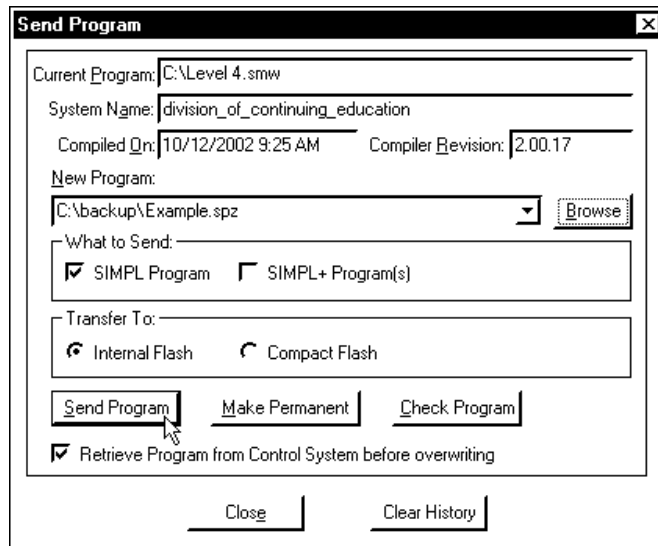
“Send Program” Window

- To verify that the program has been transferred successfully, select **Diagnostics | Report Program Information** or press **F7**. This should display a window that provides details about the current program loaded into the control system.

Uploading a VT Pro-e Project

The TPS-4500V/LV touchpanel source file has the extension .vtp. A compiled VT Pro-e file has the extension .vtz.

The VT Pro-e file can be uploaded to the touchpanel using VT Pro-e or via the Crestron Viewport.

Upload via VT Pro-e

- Start VT Pro-e.
- Select **File | Open | Project** to view the “Open” window, navigate to the VT Pro-e file (.vtp), and click **Open**.
- Select **File | Upload Project**. This automatically selects the compiled .vtz file.

Upload via Crestron Viewport

- Verify that the procedure for “Communication Settings” that begins on page 33 has been performed.
- As shown after this step, select **File Transfer | Send Touchpanel** (alternatively, press **Alt+T**) from the Viewport menu.

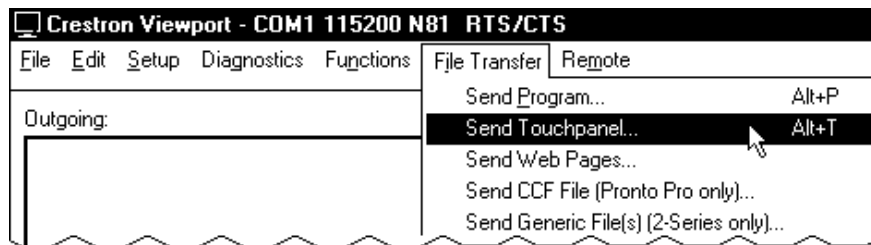
File Transfer | Send Touchpanel Command

- As shown after this step, select the Net ID of the TPS-4500V/LV touchpanel and then click **OK**. The “Touch Panel Transfer” window appears (refer to the subsequent graphic).

“Select Network ID” Window

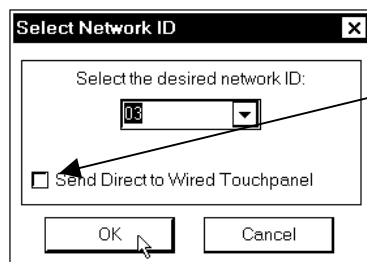

Check *Send Direct to Wired Touchpanel* if connected via RS-232 directly to touchpanel.

NOTE: If problems occur when transferring any Cresnet file (touchpanel project/firmware), lower the port speed baud rate to 38400 to match the Cresnet bus speed when transferring through a control system.

“Touch Panel Transfer” Window

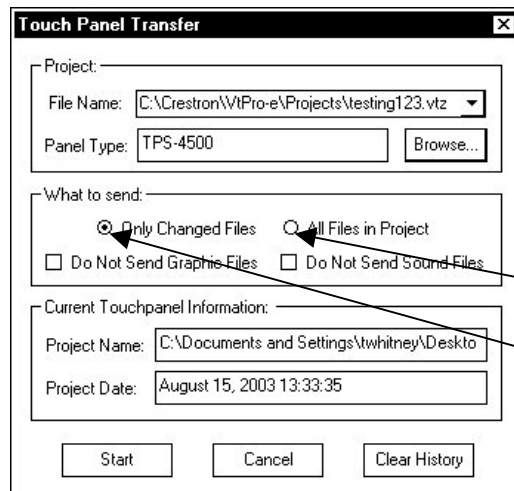

Each time a project is selected using the **Browse** command, that project is added to the **File Name** drop-down list. This makes it convenient to recall projects without need to browse to a directory. To delete the list click **Clear History**.

All Files in Project: sends the entire project.

Only Changed Files: sends only the files that are different from those that are currently stored in the panel. Note that if any pages in the panel are not present in the project, those pages will be deleted from the panel.

Additional choices include **Do not send graphic files** and **Do not send sound files**. These are often very large files that take a long time to load.

- Click **Browse**. The “Open” window appears as shown in the following illustration.

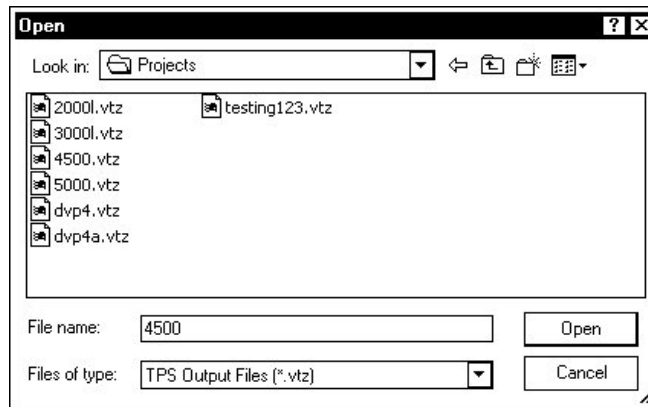
“Open” Window

5. Select the VT Pro-e (.vtz) file and click **Open**. The transfer will complete automatically.

Firmware Upgrade

A firmware upgrade file has the extension .csf.

To take advantage of all the TPS-4500V/LV features, it is important that the unit contains the latest firmware available. Therefore, please check the Crestron website (http://www.crestron.com/downloads/software_updates.asp) for the latest version of firmware. Not every product has a firmware upgrade, but as Crestron improves functions, adds new features, and extends the capabilities of its products, firmware upgrades are posted. To upgrade the firmware, complete the following steps.

NOTE: The following is the acceptable file extension for a firmware update file:
 .csf *TPS.V.XXXXX.csf* (panel firmware)

1. Make sure that “Communication Settings” that begins on page 33 has been performed.
2. As shown after this step, select **File Transfer | Update Touchpanel Firmware** from the Viewport menu.

File Transfer | Update Touchpanel Firmware Command

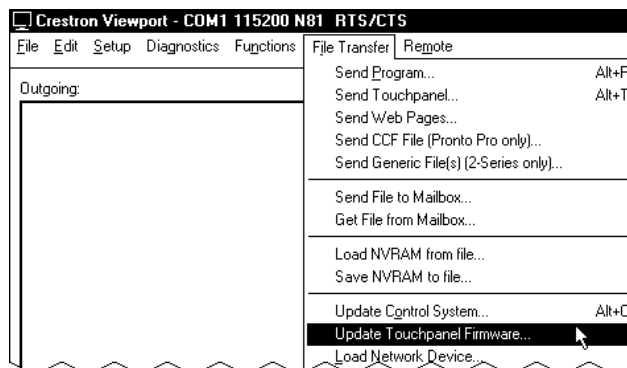

3. As shown after this step, select the Net ID of the TPS-4500V/LV touchpanel and then click **OK**. The “Open” window appears (refer to the subsequent graphic).

“Select Network ID” Window

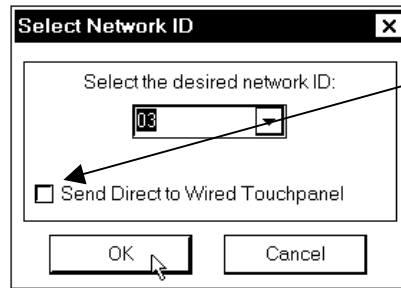

Check *Send Direct to Wired Touchpanel* if connected via RS-232 directly to touchpanel.

Select CSF File

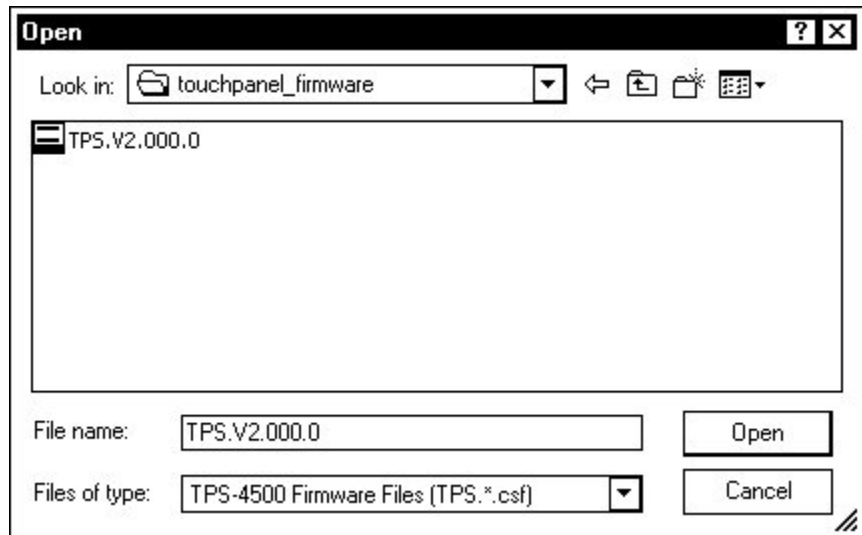

4. Browse to the .csf file and click **Open** to begin the transfer.

Problem Solving

Troubleshooting

The table after this paragraph provides corrective action for possible trouble situations. If further assistance is required, please contact a Crestron customer service representative.

TPS-4500V/LV Touchpanel Troubleshooting

TROUBLE	POSSIBLE CAUSE(S)	CORRECTIVE ACTION
Touchpanel does not function.	Touchpanel is not communicating with the network.	Use Performance Viewport (via SIMPL Windows or VT Pro-e) to poll the network. Verify network connection to the touchpanel.
	Touchpanel is not receiving network power.	Confirm that power is supplied to the network.
	Touchpanel is not receiving power from a Crestron power source.	Use a Crestron control system or an approved Crestron power supply.
	Touchpanel is incorrectly calibrated.	Enter "SETUP MODE" and recalibrate.
Touchpanel is not responding.	Incorrect network wiring.	Touch the screen to remove the message and verify correct wiring to all connectors.
	Touchpanel Cresnet ID is not set to match the Net ID in the SIMPL program.	Touch the screen to remove the message and enter Performance Viewport (via SIMPL Windows or VT Pro-e) to poll the network. Verify that the Cresnet ID for the touchpanel is properly set to match the Net ID in the SIMPL program.
	Touchpanel Cresnet ID is not unique, two or more units share the same ID.	Enter Performance Viewport (via SIMPL Windows or VT Pro-e) to poll the network and verify that each ID is used only once.
Touchpanel display is dark.	Standby timeout has elapsed.	Touch the screen to reactivate.
	Screen brightness is improperly set.	Enter "SETUP MODE" and alter screen brightness from the setup menu.
Unexpected response from the touchpanel.	Touchpanel is incorrectly calibrated.	Enter "SETUP MODE" and recalibrate.

(continued on next page)

TPS-4500V/LV Touchpanel Troubleshooting (continued)

TROUBLE	POSSIBLE CAUSE(S)	CORRECTIVE ACTION
Video window in touchpanel has no display.	Improper video connection.	Verify proper connections on the touchpanel or interface module.
	Incorrect video format selection.	Select the proper video input configuration in the touchpanel configuration SETUP MENU.
	Incorrect VT Pro-e project file loaded.	Make sure that video window object resides in project, re-compile, and reload.
	TPS-4500IMPC has no power.	Remove power from TPS-4500V and plug into TPS-4500IMPC.
Video colors are wrong and/or moving.	Touchpanel is set to Auto-Detect or S-Video when a composite signal is plugged into the touchpanel.	Switch to "Composite" video.

Further Inquiries

If after reviewing this Operations Guide, you cannot locate specific information or have questions, please take advantage of the Crestron award winning customer service team by calling:

- In the US and Canada, call the Crestron corporate headquarters at 1-888-CRESTRON [1-888-273-7876].
- In Europe, call Crestron International at +32-15-50-99-50.
- In Asia, call Crestron Asia at +852-2341-2016.
- In Latin America, call Crestron Latin America at +5255-5093-2160.
- In Australia and New Zealand, call Crestron Pacific at +613-9480-2999.

Future Updates

As Crestron improves functions, adds new features, and extends the capabilities of the TPS-4500V and TPS-4500LV, additional information may be made available as manual updates. These updates are solely electronic and serve as intermediary supplements prior to the release of a complete technical documentation revision.

Check the Crestron website (www.crestron.com) periodically for manual update availability and its relevance. Updates are available from the Downloads | Product Manuals section and are identified as an "Addendum" in the Download column.

Appendix A: RS-232 Protocol

TPS-4500V/LV touchpanels support panel operation via a host computer through the RS-232 port. While in this mode, the touchpanel can be used as a stand-alone controller to a host computer running a third-party or custom program. Crestron recommends that the following serial data format is set.

Suggested Serial Data Format

Baud Rate: 38400	Data Bits: 8	Parity: None	Stop Bits: 1
------------------	--------------	--------------	--------------

These settings may be altered via the RS-232 Menu when configuring the touchpanel, however, doing so may prevent Crestron supplied software from operating with the touchpanel. Low baud rates will cause the panel to appear unresponsive. For example, at 300 baud, a single button press (and release) generates 12 characters and requires more than 0.333 of a second to send. Delays as short as 0.1 of a second are generally considered perceptible and somewhat annoying.

RS-232 Menu Button Selection

The screenshot shows the RS-232 MENU interface with the following sections:

- BAUDRATE:** A grid of buttons for 110, 150, 300, 600, 1200, 2400, 4800, 9600, 19200, 38400, 57600, and 115200.
- DATA BITS:** Buttons for 7 and 8.
- PARITY:** Buttons for None, Odd, and Even.
- STOP BITS:** Buttons for 1 and 2.
- RS-232 Port Selection:** A vertical stack of buttons: RS-232 Port for Console, RS-232 Port for Control, RS-232 Port for Touch Output, RS-232 Port for Mouse Input, and RS-232 Port for Ext. Touch Input.
- RTS-CTS:** Buttons for On and Off.
- XON-XOFF:** Buttons for On and Off.
- Save and Return:** A button at the bottom right.

To enable this capability, select this button

Command Format - Command format for all items sent to or from the touchpanel is very simple. All items are ASCII strings terminated by a <cr>. Line feed characters are ignored, thus <cr><lf> or <lf><cr> are also acceptable line terminators. When the touchpanel sends a line, it is always terminated with <cr><lf>.

For all strings, the first character determines command type. Numeric arguments, if present, are in decimal and separated by commas. No control characters are embedded in the strings to ease processing the strings with high-level languages. Be careful when using commas in BASIC, because BASIC uses commas for field separators when reading strings from a file using the INPUT # statement. Since we are dealing with complete lines, use the LINE INPUT # statement to cure this problem.

P<#> and R<#> Commands - When in RUN mode, pressing a button (assuming that it has been joined) generates a six-character code in the format P###<cr><lf>, where ### is a three-character decimal number in the range of 1 through 4000, providing for up to 4000 functions. When the button is released, a similar code is generated, with an 'R' in place of the 'P'. Given that only one button may be pressed

at a time, an 'R' code always follows a 'P' code. A fixed three-digit format is used to simplify software on the host.

Codes may be sent to the touchpanel in the same form as they are received. The 'P' form turns on a function and the 'R' form turns off a function; sending back information received from the touchpanel (i.e., jumping pins 2 and 3 on the RS-232 port) makes the buttons momentary. Notice that the touchpanel responds to P and R commands even when configured for other interface modes. Selecting an RS-232 interface mode merely enables P and R commands to be issued. In addition, the fixed format is not required for commands sent to the touchpanel; P1, P01, and P001 are all perfectly valid commands.

Compared to running on Cresnet, an RS-232 interface to a personal computer is slower, provides less features (such as tracking, among others), is less noise immune (Cresnet uses balanced transmission for high common mode rejection, RS-232 does not), and requires the user to supply the control logic program in the PC.

V<chan>,<level> Command - Levels in gauge and slider objects may be set through the RS-232 port. The command contains both the object channel number (1-255) and level (0-65535) in decimal separated by a comma. For example, V6,32768 would set channel 6 to level 128, or half way up.

One quick note on baud rate and smooth ramping. Ramping is accomplished by sending successive levels to the object. To do this in 64 levels over three seconds, for example, requires about 576 bytes worth of commands to be sent, and could not be accomplished at any rate less than 2400 baud. Obviously, ramping several objects at once requires a baud rate several times as high.

Indirect Text – TPS-4500V/LV touchpanels support a feature that permits the text field in any user-defined button to be altered on the fly in RUN mode. This is accomplished by substituting a text pointer for the text in the button. The text pointer informs the panel to use the contents of a variable that may be dynamically redefined as the text field for the button. This presents a considerable advantage over other methods in that changing screens does not destroy information and that information may be placed in buttons not currently displayed.

The text pointer is a number in the range of '1' through '127' preceded by the "pound" symbol (#). If [text...] is omitted, the text field is cleared. If [text...] exists, it is added to the text field. For example, consider the following string:

```
#3,Now is the time<cr>
#3,for all good men<cr>
#3,to come to the<cr>
#3,aid of the party<cr>
```

Assuming that a button with an #3 text pointer was being displayed, the contents of the button would be changed to:

```
Now is the time
for all good men
to come to the
aid of the party
```

NOTE: To clear the text field for this example, type in "#3<cr>".

As each line is entered, the display is updated. Since the text may be placed in several different buttons, no boundary checking is done to see if the text fits in the button. If the text overflows the button/boundaries, it remains centered in the button/boundary.

Appendix B: Cutout Detail of Supplied Template

Use the alphanumeric codes in the illustration and table to obtain the cutout dimensions for the lectern mount models when mounting without the BB-5000. However, Crestron recommends that the supplied template be used to avoid error.

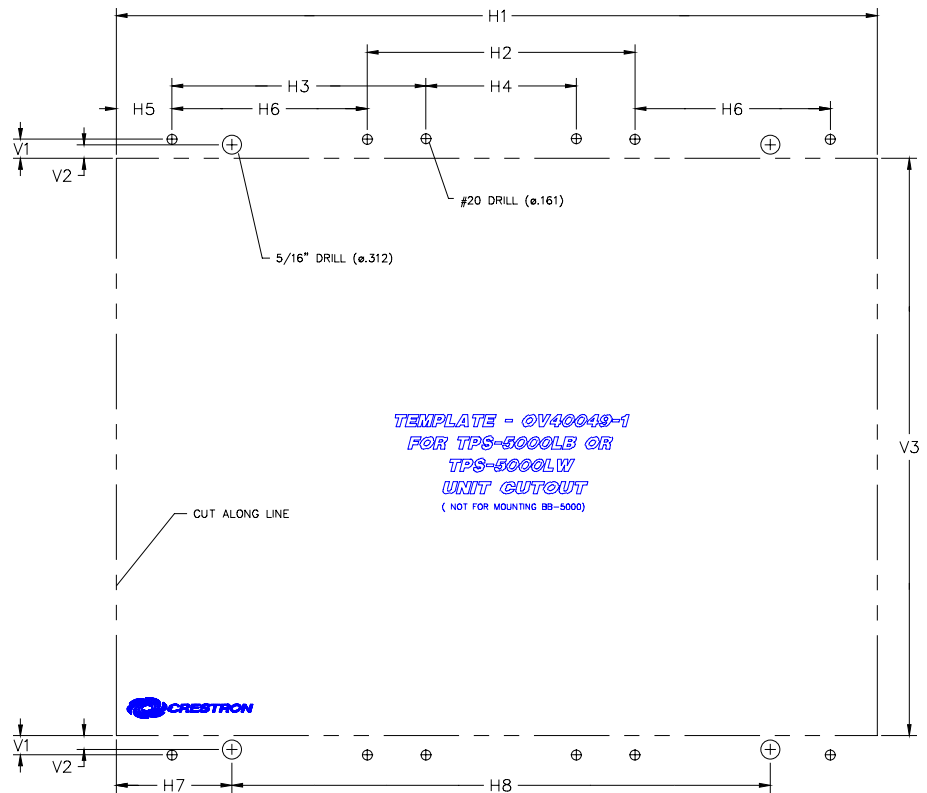

VERTICAL MEASUREMENTS	
V1	= 0.320 in (0.813 cm)
V2	= 0.230 in (0.584 cm)
V3	= 9.583 in (24.341 cm)

HORIZONTAL MEASUREMENTS	
H1	= 12.655 in (32.144 cm)
H2	= 4.452 in (11.308 cm)
H3	= 4.226 in (10.734 cm)
H4	= 2.500 in (6.350 cm)
H5	= 0.923 in (2.344 cm)
H6	= 3.250 in (8.255 cm)
H7	= 1.921 in (4.879 cm)
H8	= 8.954 in (22.743 cm)

Appendix C: Configuring the RS-232 Port for Use

To configure the RS-232 port of the TPS-4500V/LV, a local PC that contains a Crestron Viewport is required. The Viewport is one of the development tools that is part of Crestron SIMPL Windows or VT Pro-e software.

Obtaining Communications

Refer to “Communication Settings” on page 33 for detailed instructions on connecting a PC to the touchpanel.

Configuration Options

There are several RS-232 communication options (at the time of this printing, these were available):

- **CONSOLE** – console active on RS-232 port. Use to load programs, firmware, or to set configuration. This is the default. Use this configuration if no other option is appropriate.
- **CONTROL** – activates special control mode. Use for control by non-Crestron device or within a non-Crestron control system. Refer to “Appendix A: RS-232 Protocol” on page 42. For details.
- **TOUCHOUT** – touchscreen output sent to RS-232 port. Use for serial mouse control or Telestrator output. Directly connect computer or Telestrator box to RS-232 port on TPS-4500V/LV (i.e., touch screen output). For example, use when an RGB window with tablet overlay on the TPS panel acts as a serial mouse controller for a PC. In this case, use the Crestron Serial Mouse Control Driver (tpad.exe), which can be downloaded from the Downloads | Software Updates section of the Crestron website (www.crestron.com). Another use is with the Pointmaker® telestrator. For details, refer to the Telestrator Integration Guide, which can be downloaded from the Downloads | Product Manuals section of the Crestron website (www.crestron.com).
- **MOUSE** – RS-232 port used for mouse input. For use with a Microsoft® Compatible Serial Mouse as a pointing device on the TPS-4500V/LV. Also known as “Touch the PC”.
- **EXT_TOUCH** – RS-232 port used for external touch screen input (i.e., SMART Matisse Overlay or Microtouch Display).

RS-232 Port Configuration

After establishing communication, the RS-232 can now be configured for communication with an option. Complete the following steps in the order provided.

1. From the “TPS>” prompt, enter the following command:

```
rs232 ?
```

- The TPS-4500V/LV responds with the following:

```
RS232MODE [CONSOLE|CONTROL|RF|TOUCHOUT|MOUSE|EXT_TOUCH]
CONSOLE - console active on RS232 port
CONTROL - activates special control mode.
RF - RF wireless interface.
TOUCHOUT - touchscreen output sent to RS232 port.
MOUSE - rs232 port used for mouse input
EXT_TOUCH - rs232 port used for ext. touchscreen input
No parameter - display current setting
```

- Enter a command that chooses one of the RS-232 communication options. Use the same spelling as shown in the last touchpanel response.

- The TPS-4500V/LV responds with the following:

```
New RS232mode set. Reboot to take effect.
```

- Enter the following command:

```
reboot
```

- The TPS-4500V/LV responds with the following:

```
Rebooting system. Please wait.
```

- From the Viewport, select **Remote | Remote Console | Disconnect**.

At this point, the PC and the TPS-4500V/LV are no longer communicating. Assuming that the touchpanel is properly connected for use (as shown in the diagram for “Communication Settings” on page 33) and the control system is connected to the PC, the setup screens can be displayed to set the Net ID and other configurations.

NOTE: Alternatively, use a Cresnet command from the Viewport (communicating to the control system) to access the setup screens. Verify the Net ID of the TPS-4500V/LV and select **Functions | Put Touch Panel into Setup Mode**. Enter the Net ID and click **OK**.

Software License Agreement

This License Agreement (“Agreement”) is a legal contract between you (either an individual or a single business entity) and Crestron Electronics, Inc. (“Crestron”) for software referenced in this guide, which includes computer software and, as applicable, associated media, printed materials, and “online” or electronic documentation (the “Software”).

BY INSTALLING, COPYING, OR OTHERWISE USING THE SOFTWARE, YOU REPRESENT THAT YOU ARE AN AUTHORIZED DEALER OF CRESTRON PRODUCTS OR A CRESTRON AUTHORIZED INDEPENDENT PROGRAMMER AND YOU AGREE TO BE BOUND BY THE TERMS OF THIS AGREEMENT. IF YOU DO NOT AGREE TO THE TERMS OF THIS AGREEMENT, DO NOT INSTALL OR USE THE SOFTWARE.

IF YOU HAVE PAID A FEE FOR THIS LICENSE AND DO NOT ACCEPT THE TERMS OF THIS AGREEMENT, CRESTRON WILL REFUND THE FEE TO YOU PROVIDED YOU (1) CLICK THE DO NOT ACCEPT BUTTON, (2) DO NOT INSTALL THE SOFTWARE AND (3) RETURN ALL SOFTWARE, MEDIA AND OTHER DOCUMENTATION AND MATERIALS PROVIDED WITH THE SOFTWARE TO CRESTRON AT: CRESTRON ELECTRONICS, INC., 15 VOLVO DRIVE, ROCKLEIGH, NEW JERSEY 07647, WITHIN 30 DAYS OF PAYMENT.

LICENSE TERMS

Crestron hereby grants You and You accept a nonexclusive, nontransferable license to use the Software (a) in machine readable object code together with the related explanatory written materials provided by Crestron (b) on a central processing unit (“CPU”) owned or leased or otherwise controlled exclusively by You, and (c) only as authorized in this Agreement and the related explanatory files and written materials provided by Crestron.

If this software requires payment for a license, you may make one backup copy of the Software, provided Your backup copy is not installed or used on any CPU. You may not transfer the rights of this Agreement to a backup copy unless the installed copy of the Software is destroyed or otherwise inoperable and You transfer all rights in the Software.

You may not transfer the license granted pursuant to this Agreement or assign this Agreement without the express written consent of Crestron.

If this software requires payment for a license, the total number of CPU’s on which all versions of the Software are installed may not exceed one per license fee (1) and no concurrent, server or network use of the Software (including any permitted back-up copies) is permitted, including but not limited to using the Software (a) either directly or through commands, data or instructions from or to another computer (b) for local, campus or wide area network, internet or web hosting services; or (c) pursuant to any rental, sharing or “service bureau” arrangement.

The Software is designed as a software development and customization tool. As such Crestron cannot and does not guarantee any results of use of the Software or that the Software will operate error free and You acknowledge that any development that You perform using the Software or Host Application is done entirely at Your own risk.

The Software is licensed and not sold. Crestron retains ownership of the Software and all copies of the Software and reserves all rights not expressly granted in writing.

OTHER LIMITATIONS

You must be an Authorized Dealer of Crestron products or a Crestron Authorized Independent Programmer to install or use the Software. If Your status as a Crestron Authorized Dealer or Crestron Authorized Independent Programmer is terminated, Your license is also terminated.

You may not rent, lease, lend, sublicense, distribute or otherwise transfer or assign any interest in or to the Software.

You may not reverse engineer, decompile, or disassemble the Software.

You agree that the Software will not be shipped, transferred or exported into any country or used in any manner prohibited by the United States Export Administration Act or any other export laws, restrictions or regulations (“Export Laws”). By downloading or installing the Software You (a) are certifying that You are not a national of Cuba, Iran, Iraq, Libya, North Korea, Sudan, or Syria or any country to which the United States embargoes goods (b) are certifying that You are not otherwise prohibited from receiving the Software and (c) You agree to comply with the Export Laws.

If any part of this Agreement is found void and unenforceable, it will not affect the validity of the balance of the Agreement, which shall remain valid and enforceable according to its terms. This Agreement may only be modified by a writing signed by an authorized officer of Crestron. Updates may be licensed to You by Crestron with additional or different terms. This is the entire agreement between Crestron and You relating to the Software and it supersedes any prior representations, discussions, undertakings, communications or advertising relating to the Software. The failure of either party to enforce any right or take any action in the event of a breach hereunder shall constitute a waiver unless expressly acknowledged and set forth in writing by the party alleged to have provided such waiver.

If You are a business or organization, You agree that upon request from Crestron or its authorized agent, You will within thirty (30) days fully document and certify that use of any and all Software at the time of the request is in conformity with Your valid licenses from Crestron or its authorized agent.

Without prejudice to any other rights, Crestron may terminate this Agreement immediately upon notice if you fail to comply with the terms and conditions of this Agreement. In such event, you must destroy all copies of the Software and all of its component parts.

PROPRIETARY RIGHTS

Copyright. All title and copyrights in and to the Software (including, without limitation, any images, photographs, animations, video, audio, music, text, and “applets” incorporated into the Software), the accompanying media and printed materials, and any copies of the Software are owned by Crestron or its suppliers. The Software is protected by copyright laws and international treaty provisions. Therefore, you must treat the Software like any other copyrighted material, subject to the provisions of this Agreement.

Submissions. Should you decide to transmit to Crestron’s website by any means or by any media any materials or other information (including, without limitation, ideas, concepts or techniques for new or improved services and products), whether as information, feedback, data, questions, comments, suggestions or the like, you agree such submissions are unrestricted and shall be deemed non-confidential and you automatically grant Crestron and its assigns a non-exclusive, royalty-free, worldwide, perpetual, irrevocable license, with the right to sublicense, to use, copy, transmit, distribute, create derivative works of, display and perform the same.

Trademarks. CRESTRON and the Swirl Logo are registered trademarks of Crestron Electronics, Inc. You shall not remove or conceal any trademark or proprietary notice of Crestron from the Software including any back-up copy.

GOVERNING LAW

This Agreement shall be governed by the laws of the State of New Jersey, without regard to conflicts of laws principles. Any disputes between the parties to the Agreement shall be brought in the state courts in Bergen County, New Jersey or the federal courts located in the District of New Jersey. The United Nations Convention on Contracts for the International Sale of Goods, shall not apply to this Agreement.

CRESTRON LIMITED WARRANTY

CRESTRON warrants that: (a) the Software will perform substantially in accordance with the published specifications for a period of ninety (90) days from the date of receipt, and (b) that any hardware accompanying the Software will be subject to its own limited warranty as stated in its accompanying written material. Crestron shall, at its option, repair or replace or refund the license fee for any Software found defective by Crestron if notified by you within the warranty period. The foregoing remedy shall be your exclusive remedy for any claim or loss arising from the Software.

CRESTRON shall not be liable to honor warranty terms if the product has been used in any application other than that for which it was intended, or if it as been subjected to misuse, accidental damage, modification, or improper installation procedures. Furthermore, this warranty does not cover any product that has had the serial number or license code altered, defaced, improperly obtained, or removed.

Notwithstanding any agreement to maintain or correct errors or defects Crestron, shall have no obligation to service or correct any error or defect that is not reproducible by Crestron or is deemed in Crestron’s reasonable discretion to have resulted from (1) accident; unusual stress; neglect; misuse; failure of electric power, operation of the Software with other media not meeting or not maintained in accordance with the manufacturer’s specifications; or causes other than ordinary use; (2) improper installation by anyone other than Crestron or its authorized agents of the Software that deviates from any operating procedures established by Crestron in the material and files provided to You by Crestron or its authorized agent; (3) use of the Software on unauthorized hardware; or (4) modification of, alteration of, or additions to the Software undertaken by persons other than Crestron or Crestron’s authorized agents.

ANY LIABILITY OF CRESTRON FOR A DEFECTIVE COPY OF THE SOFTWARE WILL BE LIMITED EXCLUSIVELY TO REPAIR OR REPLACEMENT OF YOUR COPY OF THE SOFTWARE WITH ANOTHER COPY OR REFUND OF THE INITIAL LICENSE FEE CRESTRON RECEIVED FROM YOU FOR THE DEFECTIVE COPY OF THE PRODUCT. THIS WARRANTY SHALL BE THE SOLE AND EXCLUSIVE REMEDY TO YOU. IN NO EVENT SHALL CRESTRON BE LIABLE FOR INCIDENTAL, CONSEQUENTIAL, SPECIAL OR PUNITIVE DAMAGES OF ANY KIND (PROPERTY OR ECONOMIC DAMAGES INCLUSIVE), EVEN IF A CRESTRON REPRESENTATIVE HAS BEEN ADVISED OF THE POSSIBILITY OF SUCH DAMAGES OR OF ANY CLAIM BY ANY THIRD PARTY. CRESTRON MAKES NO WARRANTIES, EXPRESS OR IMPLIED, AS TO TITLE OR INFRINGEMENT OF THIRD-PARTY RIGHTS, MERCHANTABILITY OR FITNESS FOR ANY PARTICULAR PURPOSE, OR ANY OTHER WARRANTIES, NOR AUTHORIZES ANY OTHER PARTY TO OFFER ANY WARRANTIES, INCLUDING WARRANTIES OF MERCHANTABILITY FOR THIS PRODUCT. THIS WARRANTY STATEMENT SUPERSEDES ALL PREVIOUS WARRANTIES.

Return and Warranty Policies

Merchandise Returns / Repair Service

1. No merchandise may be returned for credit, exchange, or service without prior authorization from CRESTRON. To obtain warranty service for CRESTRON products, contact the factory and request an RMA (Return Merchandise Authorization) number. Enclose a note specifying the nature of the problem, name and phone number of contact person, RMA number, and return address.
2. Products may be returned for credit, exchange, or service with a CRESTRON Return Merchandise Authorization (RMA) number. Authorized returns must be shipped freight prepaid to CRESTRON, 6 Volvo Drive Rockleigh, N.J., or its authorized subsidiaries, with RMA number clearly marked on the outside of all cartons. Shipments arriving freight collect or without an RMA number shall be subject to refusal. CRESTRON reserves the right in its sole and absolute discretion to charge a 15% restocking fee, plus shipping costs, on any products returned with an RMA.
3. Return freight charges following repair of items under warranty shall be paid by CRESTRON, shipping by standard ground carrier. In the event repairs are found to be non-warranty, return freight costs shall be paid by the purchaser.

CRESTRON Limited Warranty

CRESTRON ELECTRONICS, Inc. warrants its products to be free from manufacturing defects in materials and workmanship under normal use for a period of three (3) years from the date of purchase from CRESTRON, with the following exceptions: disk drives and any other moving or rotating mechanical parts, pan/tilt heads and power supplies are covered for a period of one (1) year; touchscreen display and overlay components are covered for 90 days; batteries and incandescent lamps are not covered.

This warranty extends to products purchased directly from CRESTRON or an authorized CRESTRON dealer. Purchasers should inquire of the dealer regarding the nature and extent of the dealer's warranty, if any.

CRESTRON shall not be liable to honor the terms of this warranty if the product has been used in any application other than that for which it was intended, or if it has been subjected to misuse, accidental damage, modification, or improper installation procedures. Furthermore, this warranty does not cover any product that has had the serial number altered, defaced, or removed.

This warranty shall be the sole and exclusive remedy to the original purchaser. In no event shall CRESTRON be liable for incidental or consequential damages of any kind (property or economic damages inclusive) arising from the sale or use of this equipment. CRESTRON is not liable for any claim made by a third party or made by the purchaser for a third party.

CRESTRON shall, at its option, repair or replace any product found defective, without charge for parts or labor. Repaired or replaced equipment and parts supplied under this warranty shall be covered only by the unexpired portion of the warranty.

Except as expressly set forth in this warranty, CRESTRON makes no other warranties, expressed or implied, nor authorizes any other party to offer any warranty, including any implied warranties of merchantability or fitness for a particular purpose. Any implied warranties that may be imposed by law are limited to the terms of this limited warranty. This warranty statement supercedes all previous warranties.

Trademark Information

All brand names, product names, and trademarks are the sole property of their respective owners. Windows is a registered trademark of Microsoft Corporation. Windows95/98/Me/XP and WindowsNT/2000 are trademarks of Microsoft Corporation.

This page intentionally left blank.

This page intentionally left blank.



Crestron Electronics, Inc.
15 Volvo Drive Rockleigh, NJ 07647
Tel: 888.CRESTRON
Fax: 201.767.7576
www.crestron.com

Operations Guide – DOC. 6160
10.03

Specifications subject to
change without notice.