

---

**BA10/20/30 SERIES**

**USER'S MANUAL**

**P/N: EDA121 (V1.6)**

---



AEROTECH, Inc. • 101 Zeta Drive • Pittsburgh, PA. 15238-2897 • USA

Phone (412) 963-7470 • Fax (412) 963-7459

Product Service: (412) 967-6440; (412) 967-6870 (Fax)

**[www.aerotech.com](http://www.aerotech.com)**

If you should have any questions about the BA10, 20, or 30 and/or comments regarding the documentation, please refer to Aerotech online at:

<http://www.aerotech.com>.

For your convenience, a product registration form is available at our web site.

Our web site is continually updated with new product information, free downloadable software and special pricing on selected products.

The BA Series User's Manual Revision History:

Rev 1.0a	February 21, 1995
Rev 1.1	July 27, 1995
Rev 1.1a	November 1995
Rev 1.2	May 23, 1996
Rev 1.3	May 15, 1997
Rev 1.3a	September 30, 1997
Rev 1.4	February 11, 1998
Rev 1.4a	March 8, 2000
Rev 1.5	December 13, 2000
Rev 1.5a	February 13, 2001
Rev 1.6	February 5, 2002

**TABLE OF CONTENTS**

<b>CHAPTER 1: INTRODUCTION</b> .....	1-1
1.1. Product Overview .....	1-1
1.2. Models, Options and Packages .....	1-2
1.3. BA Drive Package .....	1-3
1.4. Hardware Overview and Function .....	1-4
1.4.1. Motor and AC Power Connections .....	1-4
1.4.2. DIP Switch .....	1-5
1.4.3. Potentiometers (POTs) .....	1-6
1.4.4. Connector P1 and Enable Indicator .....	1-6
1.4.5. I/O Circuitry .....	1-9
1.5. Safety Procedures and Warnings .....	1-11
<b>CHAPTER 2: INSTALLATION AND OPERATION</b> .....	2-1
2.1. Introduction .....	2-1
2.2. Jumper Selections .....	2-1
2.3. Wiring, Grounding, and Shielding Techniques .....	2-4
2.3.1. Minimizing EMI Interference .....	2-4
2.3.2. Fusing and Inrush Limiting .....	2-5
2.3.2.1. 40 Volt Option .....	2-6
2.3.3. Minimizing 50/60 HZ Line Interference .....	2-7
2.4. Integrated Configurations .....	2-9
2.4.1. Velocity Command Configuration .....	2-9
2.4.2. Current Command Configuration .....	2-10
2.4.3. Dual-Phase Command Configuration .....	2-11
2.5. Control Connections .....	2-12
2.5.1. Setup - Torque Command Mode (Current) .....	2-12
2.5.2. Setup - Velocity Command Mode .....	2-12
2.5.3. Setup - Dual-phase Command Mode .....	2-14
2.6. Motor Phasing Process .....	2-15
2.6.1. Determining Phase/Hall Sequence .....	2-15
2.7. Current Regulator Adjustment .....	2-17
<b>CHAPTER 3: TECHNICAL DETAILS</b> .....	3-1
3.1. Part Number and Ordering Information .....	3-1
3.2. Electrical Specifications .....	3-2
3.3. BA Amplifier Dimensions .....	3-5
3.4. 40/80 VDC Power Transformers .....	3-7
<b>CHAPTER 4: TROUBLESHOOTING</b> .....	4-1
4.1. Amplifier Related Problems .....	4-1
<b>APPENDIX A: GLOSSARY OF TERMS</b> .....	A-1
<b>APPENDIX B: WARRANTY AND FIELD SERVICE</b> .....	B-1
<b>APPENDIX C: CABLE DRAWINGS</b> .....	C-1

**INDEX****REVISION HISTORY**

▽ ▽ ▽

**LIST OF FIGURES**

Figure 1-1.	BA Series Amplifier .....	1-1
Figure 1-2.	Functional Diagram .....	1-3
Figure 1-3.	Amplifier Hardware.....	1-4
Figure 1-4.	Fault Output.....	1-9
Figure 1-5.	Enable/Shutdown Inputs .....	1-9
Figure 1-6.	$\pm$ Limit Inputs .....	1-10
Figure 1-7.	Hall and Encoder Inputs .....	1-10
Figure 2-1.	BA Board Assembly .....	2-3
Figure 2-2.	Wiring to Minimize EMI and Capacitive Coupling.....	2-5
Figure 2-3.	Fusing and Inrush Limiting.....	2-5
Figure 2-4.	40 Volt Option.....	2-6
Figure 2-5.	Back-propagation Line Filter Connection .....	2-7
Figure 2-6.	Isolation Transformer Connection (eliminates torque disturbance) .....	2-8
Figure 2-7.	Velocity Command Configuration.....	2-9
Figure 2-8.	Current Command Configuration .....	2-10
Figure 2-9.	Dual-Phase Command Configuration .....	2-11
Figure 2-10.	Command Signal Adjustment Portion of the Pre-Amplifier Circuit.....	2-13
Figure 2-11.	Motor Phasing .....	2-16
Figure 2-12.	Three-Phase Current Regulator Circuit .....	2-18
Figure 3-1.	BA Amps Side View .....	3-5
Figure 3-2.	BA Amp Top View (Preferred Mounting).....	3-6
Figure 3-3.	Preferred Mounting of BA Amplifiers.....	3-6
Figure C-1.	BA Feedback Cable (PFC) .....	C-1
Figure C-2.	BA10/20/30 Light Duty Brushless Motor Cable (PMC) .....	C-2

▽ ▽ ▽



**LIST OF TABLES**

Table 1-1. BA Models and Voltage Configurations..... 1-2  
Table 1-2. DIP Switch Functions ..... 1-5  
Table 1-3. Potentiometer Functions ..... 1-6  
Table 1-4. Connector P1 Pinouts ..... 1-7  
  
Table 2-1. Jumper Selections ..... 2-2  
  
Table 3-1. Ordering Information..... 3-1  
Table 3-2. Electrical Specifications ..... 3-2  
  
Table 4-1. Amplifier Faults, Causes, and Solutions..... 4-1

▽ ▽ ▽





## DECLARATION OF CONFORMITY

### Manufacturer's Name and Address

Aerotech, Inc.  
101 Zeta Drive  
Pittsburgh, PA 15238-2897

Declares that the product:

**Product Name:** Brushless Servo Amplifier (BA Series)

Conforms to the following product specifications:

**EMC:** EN 55011: 1991 Class B Emissions  
EN 50082-1: 1992 Immunity  
IEC 801-2: 1984  
IEC 801-3: 1984  
IEC 801-4: 1988  
**LVD:** IEC 204-1

and complies with EMC directive 89/336/EEC.

Pittsburgh, PA  
February, 1998

David F. Kincel   
Quality Assurance Manager

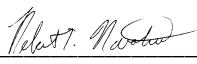
Robert Novotnak   
Engineer Verifying Compliance

### General notes concerning the test setup.

This product was tested at Washington Laboratories, LTD. in Gaithersburgh, MD on October 19, 1995. The report number is WLL 2956F.

The brushless amplifier was tested with a brushless servomotor. To ensure that the product passes the conducted emissions tests, a line filter and common mode choke must be connected to the main inputs. The filter is a Schaffner FN 2070-10-06 and the common mode choke is a Renco Electronics RL-1329-1200. Ferrite must be added to each line of the main inputs but not earth ground. In order for the product to conform to the radiated emission standards, the motor cable must be shielded and the shield must be tied to the earth ground. Ferrite must also be added (in common mode) to the motor cable but not around the shield. Finally, a metal 25-pin connector with a metal backshell must be used when making a connection to the 25-pin receptacle on the amplifier. The shield of the feedback cable must be tied to the metal backshell. Failure to follow the described procedures may cause the amplifier/motor to exceed emission limits.

▽ ▽ ▽



## CHAPTER 1: INTRODUCTION

### In This Section:

- Product Overview ..... 1-1
- Models, Options and Packages ..... 1-2
- BA Drive Package ..... 1-3
- Hardware Overview and Function ..... 1-4
- Safety Procedures and Warnings ..... 1-11

### 1.1. Product Overview

The BA series amplifiers are highly reliable brushless servo amplifiers (refer to Figure 1-1) that are easily adaptable to drive brush or brushless servomotors. The amplifiers are available in 3 peak output current ratings of 10, 20, and 30 amps. The BA amplifier package is a complete modular unit that includes heat sink, metal cover, and bus power supply that operates from 56-230 VAC. Custom packages, such as units without metalwork for direct cold plate mounting are available for the OEM with special packaging needs. The BA drives provide the designer with servo drive flexibility for use in applications such as:

- machine tools
- packaging
- labeling
- x-y stages
- inspection
- medical
- winding
- semiconductor fabrication
- food processing.



Figure 1-1. BA Series Amplifier

## 1.2. Models, Options and Packages

The BA drives are available in three models with continuous power, ranging from 1,360 to 4,080 watts. A list of these models and the available voltage configurations is shown in Table 1-1

**Table 1-1. BA Models and Voltage Configurations**

Model	Standard Voltage Configuration	Peak Output Current	Continuous Output Current (peak)	DC Bus Voltage Range (Nominal VDC)*
BA10	160V	10A	5A	80-100V, 80-160V, 80-320V
BA20	160V	20A	10A	80-100V, 80-160V, 80-320V
BA30	320V	30A	15A	160V, 160-320V

\*DC Output is a function of AC Input

The BA drives feature self-commutation with Hall effect feedback signals. 320V operation is also available for the BA drives. The BA drives include a 5 VDC, 250 mA supply to power encoders and Hall effect devices (HEDs). Each model is jumper selectable, providing the capability to drive both brush and brushless motors. The heat sink can be mounted in two different orientations, but it is recommended that this heat sink be mounted to a larger, thermally conductive surface for further heat dissipation. Complete electrical isolation is provided between the control stage and the power stage for all models of the BA series. This is accomplished with a transformer isolated control voltage power supply and opto-isolation of the drive signals, current feedback signals and fault signal between the control and power stages. Each drive is fully protected against the following fault conditions:

- control power supply under voltage
- RMS current limit exceeded
- power stage bias supplies under voltage
- over temperature
- over current
- output short circuits (phase to phase and phase to ground)
- DC bus overvoltage.

Operating modes include current command, velocity command or dual-phase command (for brushless modes of operation only). For brush modes of operation the available operating modes are current command and velocity command. Differential inputs are used for better noise immunity. Velocity feedback is from either an encoder or tachometer and logic inputs include directional current limits and shutdown. Fault, current, and velocity outputs simplify monitoring drive status.



### 1.4. Hardware Overview and Function

The BA series consist of two power connections (motor power and input power), four potentiometers, a 10-position DIP switch, an enable LED indicator lamp, and a 25-pin "D" style connector. Refer to Figure 1-3 for locations.

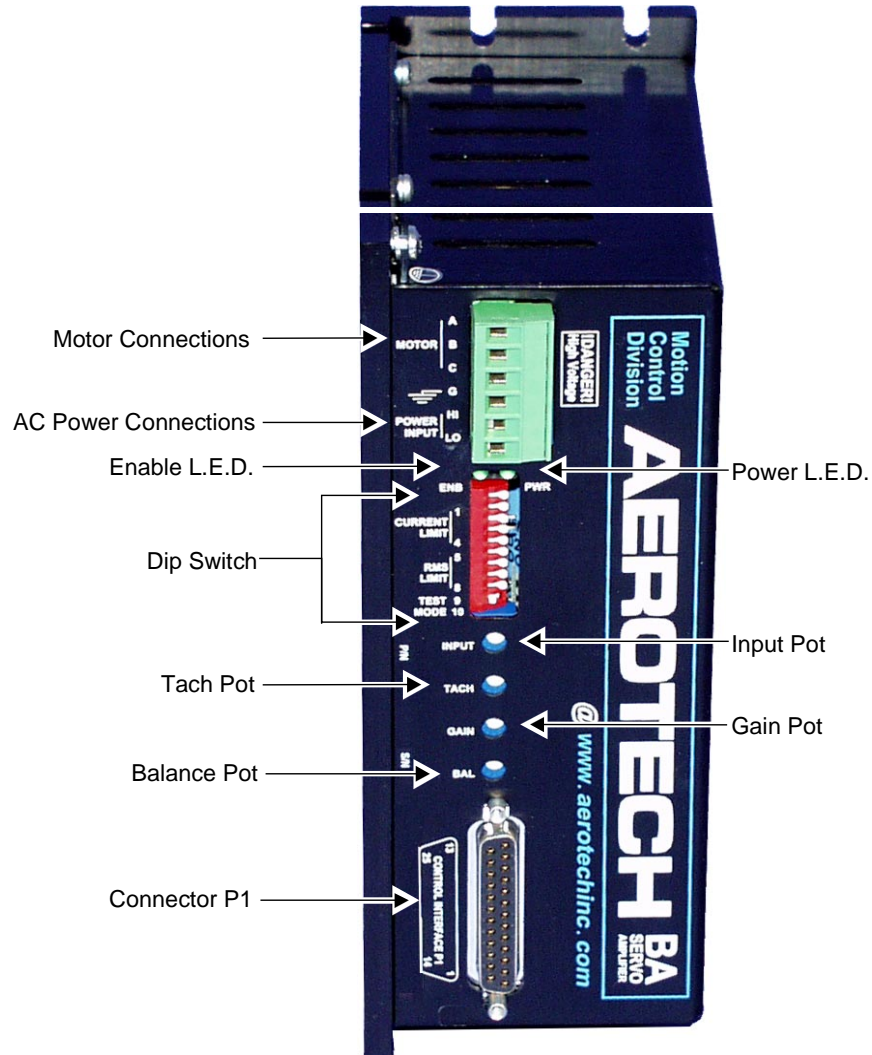
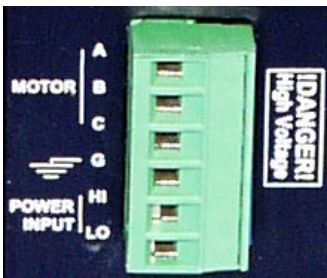

Figure 1-3. Amplifier Hardware

#### 1.4.1. Motor and AC Power Connections

The three phase motor terminal connections are made at connections **A**, **B**, and **C**. This area is designated as such on the amplifier.

Input power to the BA series amplifier is made at the **HI** (line) and **LO** (neutral) terminals with earth ground connected to  $\varnothing$  (ground). Motor frame and shield connect to a grounding stud on the heat sink.



### 1.4.2. DIP Switch

There is a 10-position DIP switch on the BA drive that provides four discrete functions. The switch permits the user to control maximum allowable current to the motor, continuous output current, velocity or current operational mode, and test mode. Figure 1-3 shows the location of this switch on the BA drive. Refer to Table 1-2 for the exact switch functions.

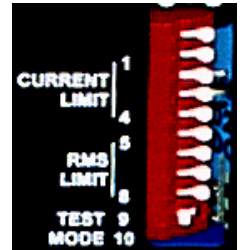
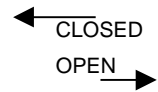

**Table 1-2. DIP Switch Functions**

	Switches	Position	Function
<b>Current limit Peak</b>	*1	closed	Peak is 6% of Ipeak
	*2	closed	Peak is 13% of Ipeak
	*3	closed	Peak is 27% of Ipeak
	*4	closed	Peak is 54% of Ipeak
* These switches affect the GAIN adjustment of the velocity loop. Maximum gain adjustment when 1 to 4 are closed.			
<b>Continuous Current Peak *</b>	5	closed	Icont is 3% of Ipeak
	6	closed	Icont is 7% of Ipeak
	7	closed	Icont is 14% of Ipeak
	8	closed	Icont is 27% of Ipeak
<b>Test</b>	9	closed	Closing this position allows the BALance potentiometer to manually control motor velocity or torque without the need of an input signal depending upon the setting of switch 10.
<b>Mode</b>	10		Velocity/Current mode - closing this position enables the current mode.

Switches 1 through 4 set the peak or maximum output current supplied to the load. Switches 5 through 8 determine the level where the continuous output current the BA amp protection circuit will produce a fault. This type of protection is known as an electronic fuse.

For low duty cycle and low acceleration system requirements, set the DIP switches equally or to next lower switch setting. For high duty cycle and high acceleration system requirements, set the DIP switches equally or to next higher switch setting.

Closing DIP switches 1 through 4 will allow peak current. Closing switches 5 through 8 will allow 50% peak continuous current for two seconds.



The following examples should be used as a guideline for setting the DIP switches.

#### Example for a BA30 - Setting Continuous Current Limits

To set the continuous current limit to 5.5A:

$5.5\text{A Continuous RMS} \times 1.414 = 7.8\text{A continuous peak}$

$(7.8\text{A continuous peak}/30\text{A max peak}) \times 100 = 26\%$ .

Open switches 5, 6, and 7; close switch 8.

#### Example for BA20 - Setting Current Limits and RMS Limits

To set the RMS limit to 5.0A (RMS) and peak current to 15A:

##### Peak Current

$(15\text{A peak}/20\text{A max peak}) \times 100 = 75\%$

Close switches 3 and 4; open switches 1 and 2.

##### RMS Current

$5.0\text{A RMS} \times 1.414 = 7\text{A continuous peak}$

$(7\text{A continuous peak}/20\text{A max peak}) = 35\%$ .

Close switches 6, 8; open switches 5 and 7.

### 1.4.3. Potentiometers (POTs)

Potentiometers **INPUT**, **TACH**, **GAIN**, and **BALance** are associated with the pre-amplifier circuit contained in the amplifier. Refer to Figure 1-3 for location of the pots on the BA drive. These potentiometers are used to adjust the pre-amplifier gain when the **MODE** switch is set for velocity control using an external DC tachometer or incremental encoder for velocity feedback. Refer to Table 1-3 for pot functions.

**Table 1-3. Potentiometer Functions**

Potentiometer	CW	CCW	Function
<b>GAIN</b>	decrease	increase	This pot adjusts the velocity loop AC gain of the pre-amplifier <sup>1</sup> .
<b>INPUT</b>	increase	decrease	This pot adjusts the DC gain of the input command present at P1 Pins 8 & 21.
<b>TACH</b>	increase	decrease	This pot adjusts the DC gain of the tach or encoder derived velocity feedback input present at P1-Pin 3.
<b>BALance</b>			Provides the means of canceling small DC offsets that may be present in the pre-amplifier circuit.

<sup>1</sup>Velocity loop GAIN adjustment is affected by current limit peak (switches 1 to 4). Maximum gain when 1 to 4 are closed.

### 1.4.4. Connector P1 and Enable Indicator

Connector **P1** (25-pin "D" type, female) provides the interface for input and output control connections. Refer to Table 1-4 for connector P1 pinouts. The LED **ENABLE** indicator will illuminate at all times until there is a fault or external shutdown, then the indicator will be off and motor power will be removed. Refer to Figure 1-3 for location of these items. A second LED will be green whenever +5V is present (Rev E and above).

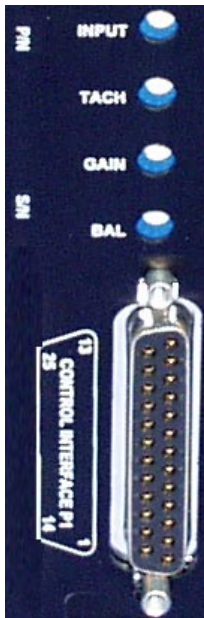



Table 1-4. Connector P1 Pinouts

Pin #	Input or Output	Signal	Function
Pin 1	shield	ground	Connection point to earth ground. Used for reducing electrical noise in control and feedback signals. Typically connected to the foil shield of a shielded cable.
Pin 2	output	power	On board 5V power supply. Pin 2 is intended for powering an encoder and can supply up to 250mA of current.
Pin 3	input	+tach	Tachometer input for velocity feedback, (encoder vs. tach velocity feedback is jumper selectable). A tachometer may be used in the velocity loop configuration to provide negative feedback to the amplifier. This allows the amplifier to close the servo loop and control the stability of the loop.
Pin 4	input <sup>(1)</sup>	Hall A	Hall effect A. One of three commutation signals used with brushless motors. Used in conjunction with Hall effect B and Hall effect C to provide motor rotor position information to the amplifier.
Pin 5	input <sup>(1)</sup>	cosine	Cosine signal from encoder. Optionally used, in conjunction with sine for deriving an electronic tachometer signal. Line receiver input
Pin 6	input	cosine-N	Compliment of cosine (P1 - 5). Line receiver input.
Pin 7	input	ground	Signal common. Electrical reference for all control circuitry on amplifier.
Pin 8	input	+input	Non-inverting input of differential input circuit. A positive voltage on this input causes CCW motor rotation (torque or velocity mode). For single ended operation, connect command to this input and ground (Pin 21 of P1).
Pin 9	input	icmda	Current command A. Jumper selectable current command input. Bypasses differential input, pre-amplifier, and self-commutation circuit.
Pin 10	input <sup>(1)</sup>	shutdown	Jumper selectable active high or active low input. Used to shut off power stage and therefore remove all power to the motor.
Pin 11	input <sup>(1)</sup>	+ilmt	Directional current limit input. When pulled to its active state, motion in the positive direction (CW motor shaft rotation) is inhibited (jumper selectable).
Pin 13		NC	
Pin 12	output	-fdbk	Current feedback monitor. When running a brushless motor, this signal represents the current in motor phase A. When running a brush motor, this signal represents the entire motor current. Scaling is as follows: BA10 3.2 Amp/V BA20 6.5 Amp/V BA30 9.7 Amp/V
Pin 14	signal common	ground	Electrical reference for all control circuitry on amplifier. This pin is intended to be used as the connection point for the signal common of an encoder. (Used in conjunction with Pin 2 as the power supply connections to an encoder.)
Pin 15	input	-tach	Recommended reference input for tachometer. This point is identical to signal common.
Pin 16	input <sup>(1)</sup>	Hall B	Hall effect B. One of three commutation signals used with brushless motors. Used in conjunction with Hall effect A and Hall effect C.

**Table 1-4. Connector P1 Pinouts Cont'd**

Pin #	Input or Output	Signal	Function
Pin 17	input <sup>(1)</sup>	Hall C	Hall effect C. One of three commutation signals used with brushless motors. Used in conjunction with Hall effect A and Hall effect B.
Pin 18	input <sup>(1)</sup>	sine	Sine signal from encoder. Optionally used, in conjunction with cosine for deriving an electronic tachometer signal. Line receiver input.
Pin 19	input	sine-N	Compliment of sine (P1- 18). Line receiver input.
Pin 20	output	power	5V on board 5V power supply.
Pin 21	input	-input	Inverting input of differential input circuit. A positive voltage on this input causes CW motor rotation (torque or velocity mode). For single ended command operation, ground this connection and connect signal to Pin 8 of P1.
Pin 22	input	icmdb	Current command B. Jumper selectable current command input. Bypasses differential input, pre-amplifier, and self-commutation.
Pin 23	output	-fault	Jumper selectable active high or active low (open collector) output. Used to indicate the status of the power stage (amplifier enabled or faulted).
Pin 24	input <sup>(1)</sup>	-ilmt	Directional current limit input. When pulled to its active state, motion in the negative direction (CCW motor shaft rotation) is inhibited (jumper selectable).
Pin 25	output	-icmd	Current command monitor. Representative of the current command. BA10 3.2 Amp/V BA20 6.5 Amp/V BA30 9.7 Amp/V

<sup>1</sup>Denotes input pull up to internal +5 V through a 10K resistor.

### 1.4.5. I/O Circuitry

The following shows the internal circuitry for the BA amplifier. Note that all of the logic inputs can tolerate +24VDC.

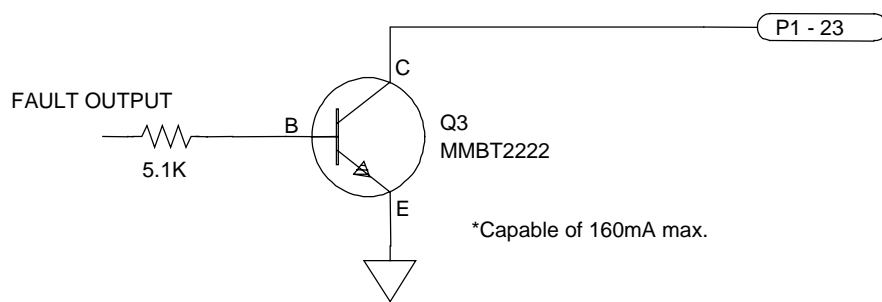

Figure 1-4. Fault Output

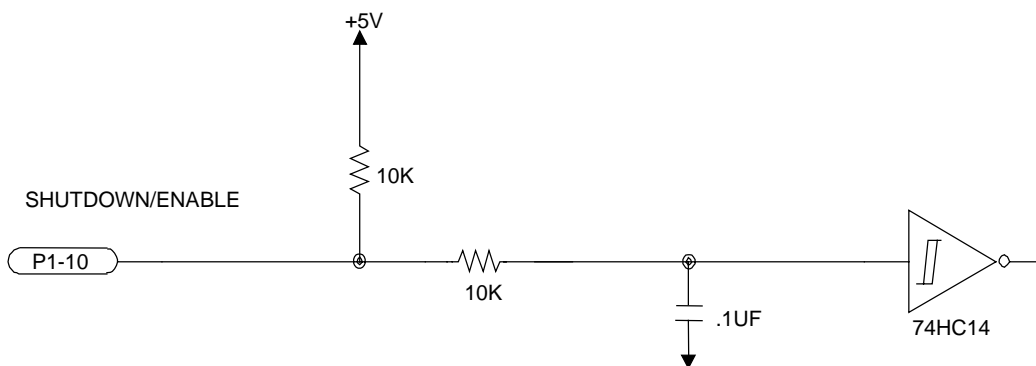

Figure 1-5. Enable/Shutdown Inputs

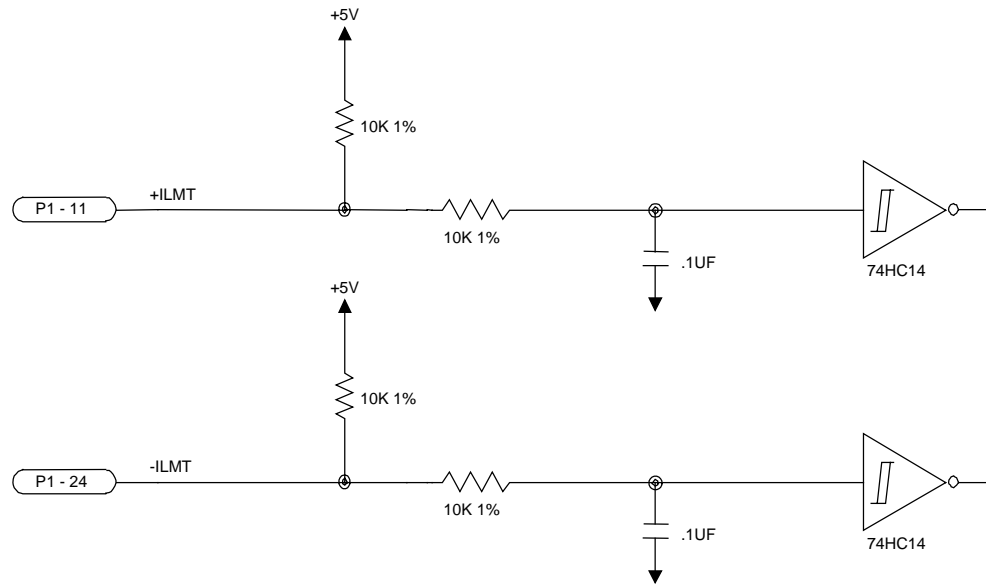

Figure 1-6. ± Limit Inputs

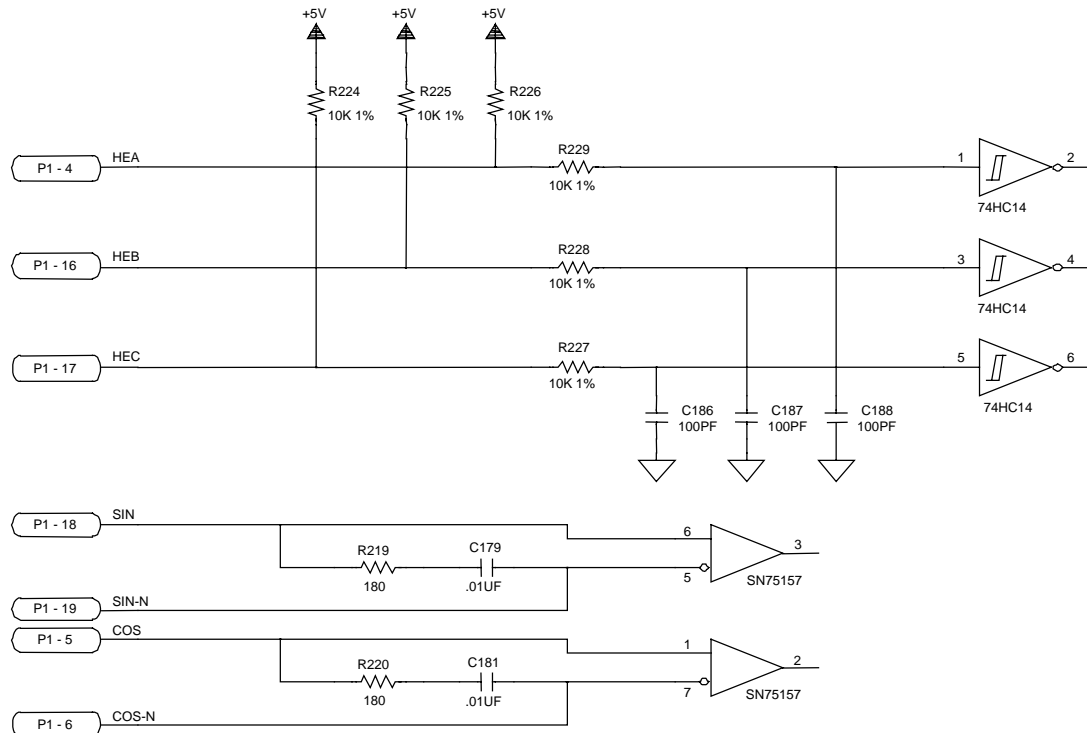

Figure 1-7. Hall and Encoder Inputs

## 1.5. Safety Procedures and Warnings

The following statements apply wherever the Warning or Danger symbol appears within this manual. Failure to observe these precautions could result in serious injury to those performing the procedures and/or damage to the equipment.

To minimize the possibility of electrical shock and bodily injury, ensure that the motor is decoupled from the mechanical system and no harm to personnel will result if the motor begins to spin.



Before performing the following steps, ensure that the motor is completely disconnected from the amplifier and the associated mechanical system.



To minimize the possibility of electrical shock and bodily injury when any electrical circuit is in use, ensure that no person comes in contact with the circuitry.



To minimize the possibility of bodily injury, make certain that all electrical power switches (all switches external to the amplifier) are in the off position prior to making any mechanical adjustments.



▽ ▽ ▽



## CHAPTER 2: INSTALLATION AND OPERATION

**In This Section:**

- Introduction .....2-1
- Jumper Selections.....2-1
- Wiring, Grounding, and Shielding Techniques .....2-4
- Integrated Configurations .....2-9
- Control Connections.....2-12
- Motor Phasing Process .....2-15
- Current Regulator Adjustment .....2-17

### 2.1. Introduction

This section covers the hardware configurations using the switches, jumpers, connectors, and power hook-ups when used with a brush or brushless DC motor. Also covered is wiring, grounding, and shielding techniques, an explanation of the current regulator adjustment, and the motor phasing process.

### 2.2. Jumper Selections

The BA series amplifiers are jumper selectable providing the user with quick reconfiguration capability of operating modes. Table 2-1 list the jumpers and the default configurations for the amplifiers. Figure 2-1 highlights where the jumpers are located on the board (with the default configurations).

**Table 2-1. Jumper Selections**

Jumpers	Positions	Function
JP2	1-2	Overvoltage monitor. Shuts off drive if bus voltage exceeds a preset threshold. (Approx. 180-190 VDC) (default on BA10-80, BA20-160).
	2-3	Shunt option. Allows optional shunt regulator to activate to pull elevated bus voltage back into range. This will, however, shut the drive off if the fuse in the shunt regulator opens (default on BA20-320, BA30-160, BA30-320).
JP3	1-2	Selects brushless mode of operation. (default).
	2-3	Selects brush mode operation.
JP4	1-2	Active high shutdown input. Logic high on P1-10 shuts off power stage. (default).
	2-3	Active low shutdown input. Logic low (0V) on P1-10 shuts off power stage.
JP5	1-2	Selects brushless mode operation. (default).
	2-3	Selects brush mode operation.
JP6	1-2	Selects brushless mode of operation. (default).
	2-3	Selects brush mode operation.
JP8	1-2	0° commutation offset (default).
	2-3	30° offset (factory option only).
JP9	1-2	Active low +ILMT. Logic low on P1-11 stops CW (+) motor movement. (default).
	2-3	Active high +ILMT. Logic (5V) on P1-11 stops CW (+) motor movement.
JP10	1-2	Active low -ILMT. Logic low on P1-24 stops CCW (-) motor movement. (default).
	2-3	Active high -ILMT. Logic high (5V) on P1-24 stops CCW (-) motor movement.
JP11	1-2	Power stage drive signal (phase A) is derived from differential pre-amp input. BA drive performs self-commutation. (default).
	2-3	Power stage drive signals are derived from input signal at P1-9. Controller must perform commutation.
JP12	2-3	Active low fault output. Open collector output P1-23 pulls to a logic low to indicate a drive fault.
	1-2	Active high fault output. Open collector output P1-23 sets to a high impedance state (must be pulled to a logic high by an external resistor) to indicate a drive fault (default).
JP13	1-2	Power stage drive signal (phase B) is derived from differential pre-amp input. Drive performs self-commutation. (default).
	2-3	Power stage drive signals are derived from input signal at P1-22. Controller must perform commutation.
JP14	2-3	Current command configuration or tachometer feedback through pin 3 of P1 in the velocity loop configuration (default).
	1-2	Electronic tachometer signal derived from encoder signals in velocity loop configuration.
JP15	1-2	Selects brushless mode operation (default).
	2-3	Selects brush mode operation.
JP22	1-2	Signal common of control section connected to earth ground (TB1 - pin 4) (default).
	2-3	Signal common, not referenced to earth ground.
JP25,26	1-2	0° commutation offset (default).
	2-3	30° commutation offset (must be changed when JP8 is 2-3).



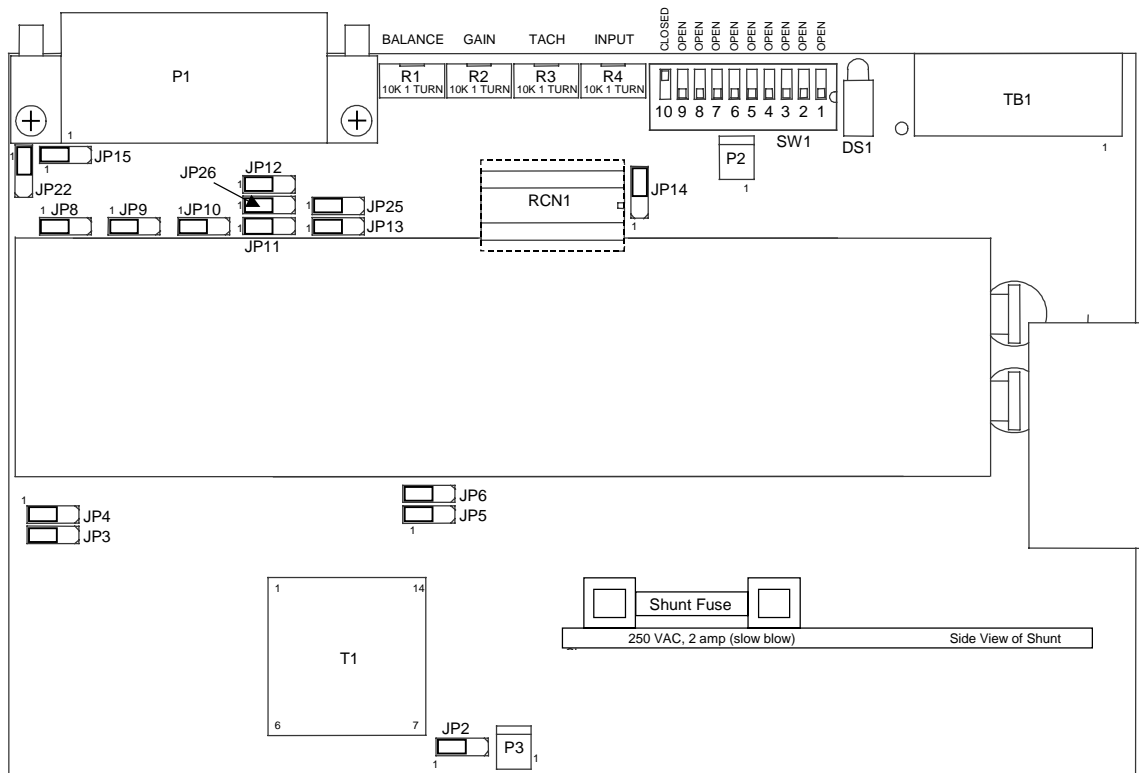

Figure 2-1. BA Board Assembly

P3 is used to connect drive signals to the shunt regulator board (optional on BA10, BA20).



### **2.3. Wiring, Grounding, and Shielding Techniques**

To reduce electrical noise in the BA Series amplifiers, the user should observe the motor and input power wiring techniques explained in the following sections. This is suitable for use on a circuit capable of delivering not more than 5000A, 240V.

#### **2.3.1. Minimizing EMI Interference**

The BA320 are high efficiency PWM amplifiers operating at a 20K Hz switching rate.

The switching time between positive and negative rails on each of the motor leads is less than 50 nano-seconds for a 320 VDC bus. This switching rate can generate Electromagnetic Interference (EMI) into the Mega Hz band. To minimize this EMI, it is recommended that the motor leads be twisted together with the motor cable grounding wire and surrounded with a foil shield. Refer to Figure 2-2.

In addition to the EMI effects, electro-static (capacitive) coupling to the motor frame is very high requiring the frame to be grounded in order to eliminate a shock hazard. Additional electro-static coupling exists between the three twisted motor leads and the foil shield of the motor cable.

This coupling forces high frequency currents to flow through the returning earth ground of the motor cable. To minimize this problem and maintain low levels of EMI radiation, perform the following.

1. Use shielded cable to carry the motor current and tie the shield to earth ground. Refer to Figure 2-2.
2. Place one toriod (ferrite) around the three motor leads (two leads for brush motors). The toriod should have 10 turns for 16 AWG wire or 7 turns for 14 AWG wire. This helps reduce the harmonics generated by the 20 KHz switching waveform. Use a Ferroxcube 500T600-3C81 core or equal. Refer to Figure 2-2.
3. Use a cable with sufficient insulation. This will reduce the capacitive coupling between the leads, which in turn reduces the current generated in the shield wire.
4. Provide strong earth ground connections to the amplifier, additional heat sink, and the motor. Offering electrical noise a low impedance path to earth ground not only reduces radiated emissions, but also improves system performance.
5. If possible, do not route motor cables near cables carrying logic signals and use shielded cable to carry logic signals.

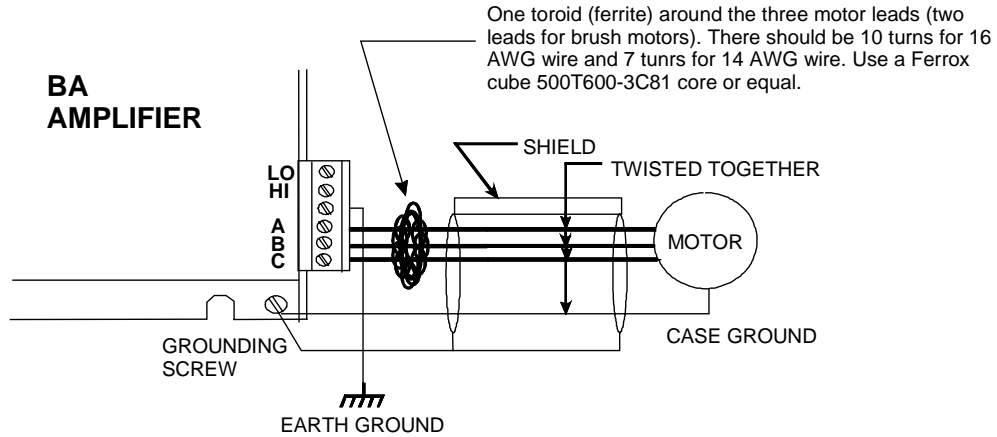

This configuration is especially important if the BA amplifier is operating at DC bus voltages of 160 VDC or 320 VDC (e.g., 115 VAC or 230 VAC input power).

Figure 2-2. Wiring to Minimize EMI and Capacitive Coupling

2.3.2. Fusing and Inrush Limiting

The BA series amplifier does not contain a fuse or any inrush limiting internally. These can be added externally to the AC input as shown in the figure below:

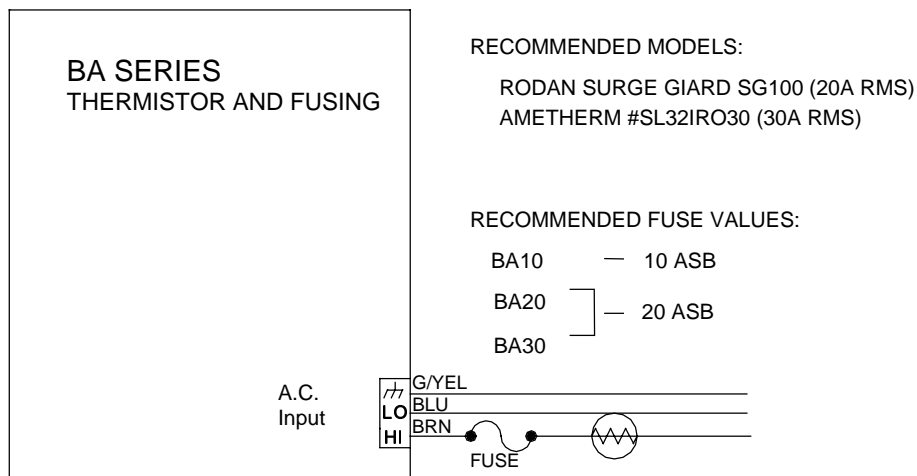

DUE TO CAPACITIVE NATURE OF AMPLIFIER INPUT CIRCUIT, CURRENT INRUSH LIMITING IS RECOMMENDED. NEGATIVE TEMPERATURE COEFFICIENT THERMISTORS ARE USED FOR THIS PURPOSE. THERMISTOR IS TO BE PLACED IN THE AC HI LINE. ONLY ONE THERMISTOR NEEDED FOR ONE AMP. ALTERNATELY, 2 THERMISTORS CAN BE USED IN AC HI & LO FOR MULTIPLE AMPS IN PARALLEL.

Figure 2-3. Fusing and Inrush Limiting

**2.3.2.1. 40 Volt Option**

If a BAXX-40 amplifier was purchased, a separate AC input has been included on the side of the amplifier. The internal power supply of the BA amplifier requires a minimum of 56 VAC input to operate properly. The figure below shows the connection to the separate AC power board. The connection is made to the AC input board with a three terminal connector (Aerotech Part #ECK00213).

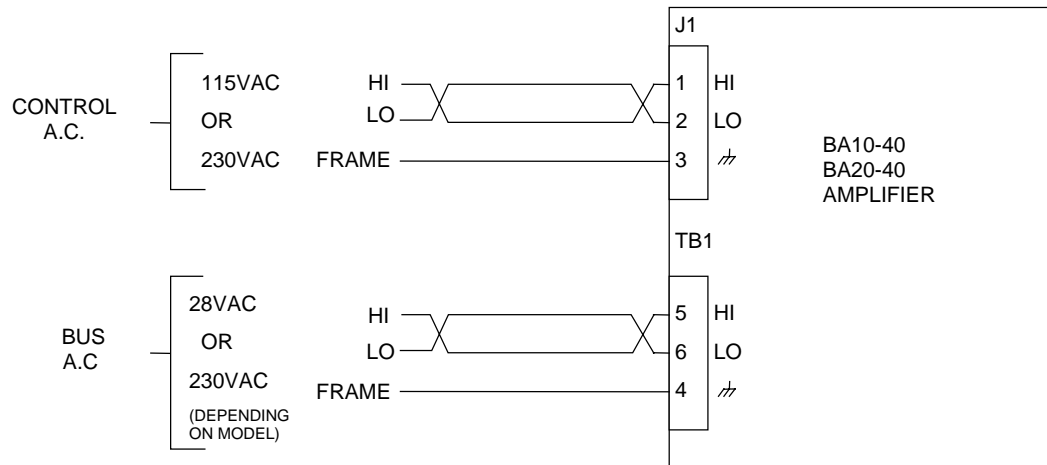
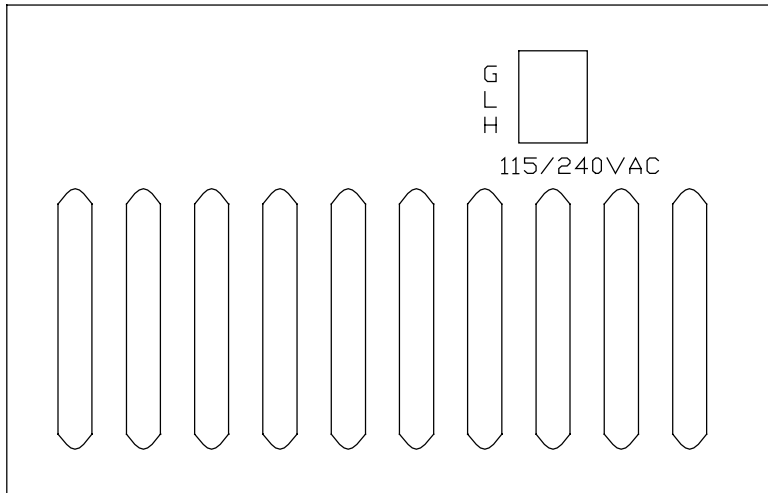
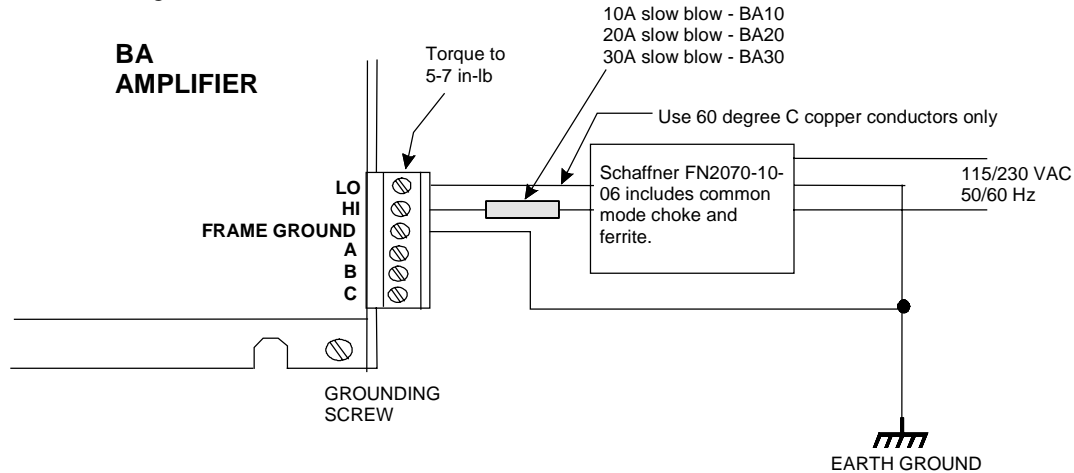

**Figure 2-4. 40 Volt Option**

### 2.3.3. Minimizing 50/60 HZ Line Interference

Operating the BA series amplifiers from an off-line source of 115 VAC or 230 VAC creates some additional problems.

First, there is a potential problem of EMI generated from the switching power stage of the BA amplifier propagating through the bridge rectifier and out through the **HI** and **LO** input AC line connections. Back-propagation of noise into the AC lines can be minimized using a line filter. An example of such a filter and proper connection to the BA amplifier is shown in Figure 2-5.



This configuration is especially important if the BA amplifier is operating at DC bus voltages of 160 VDC or 320 VDC (e.g., 115 VAC or 230 VAC input power).

**Figure 2-5. Back-propagation Line Filter Connection**

Second, another problem that potentially exists with off line connections is 50/60 Hz electrostatic coupling between the frame of the AC motor and the **HI/LO** AC input power. Since **LO** is referenced to earth ground back at the source, the DC bus of the amplifier “swings” at 50/60 Hz with respect to the motor frame.

The path of current caused by this coupling between the motor frame and the amplifier stage passes through the current feedback sensing devices of the amplifier. Depending on the magnitude of this current, a 50/60 Hz torque disturbance may be present in the position loop.

To eliminate this problem, an isolation transformer can be used to block the 50/60 Hz from being seen by the motor frame. Refer to Figure 2-6 for connection of this transformer.

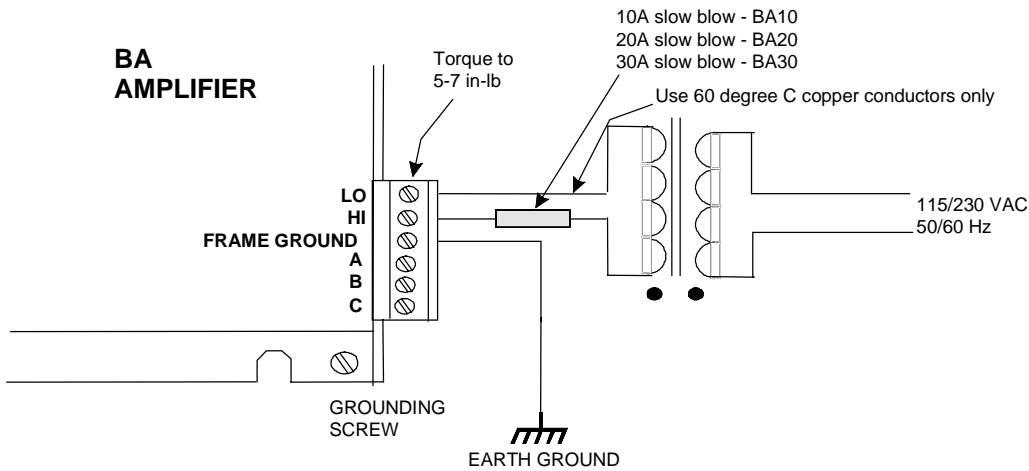

This configuration is especially important if the BA amplifier is operating at DC bus voltages of 160 VDC or 320 VDC (e.g., 115 VAC or 230 VAC input power).

**Figure 2-6. Isolation Transformer Connection (eliminates torque disturbance)**

## 2.4. Integrated Configurations

The BA amplifiers can be integrated into a system using 3 basic configurations; velocity command, current command, and dual phase command. Each of these has their advantages and disadvantages depending upon the user's specific needs.

### 2.4.1. Velocity Command Configuration

In the velocity command configuration the speed of the motor is controlled by the amplifier. A feedback signal from either a DC tachometer or an incremental encoder is monitored by the amplifier. From this signal, the amplifier adjusts the velocity of the motor accordingly depending upon the velocity command from the external controller. In this configuration, the amplifier closes and controls the velocity loop. The velocity command configuration is shown in Figure 2-7. This configuration can drive both brush and brushless DC motors.

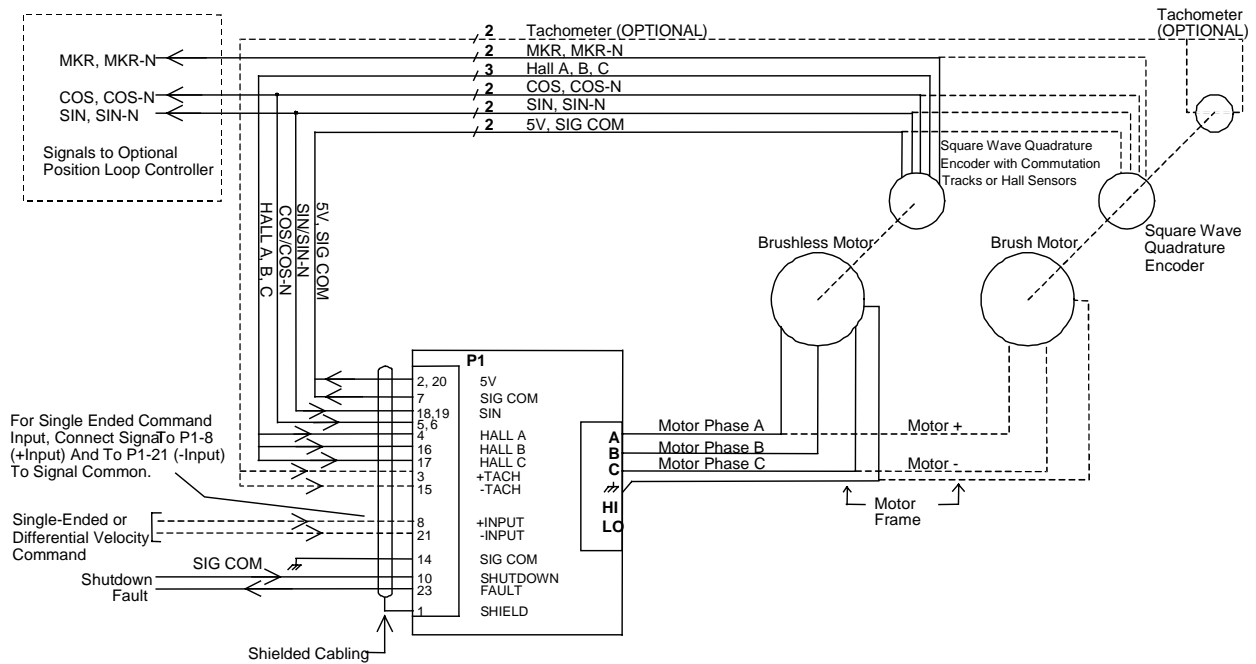

Figure 2-7. Velocity Command Configuration

### 2.4.2. Current Command Configuration

In this configuration, the output current to the motor is proportional to the current command input. The current command configuration is shown in Figure 2-8. The advantage to this configuration is the sine and cosine signals to the amplifier and a tachometer are not required. This configuration will also drive both brush and brushless DC motors.

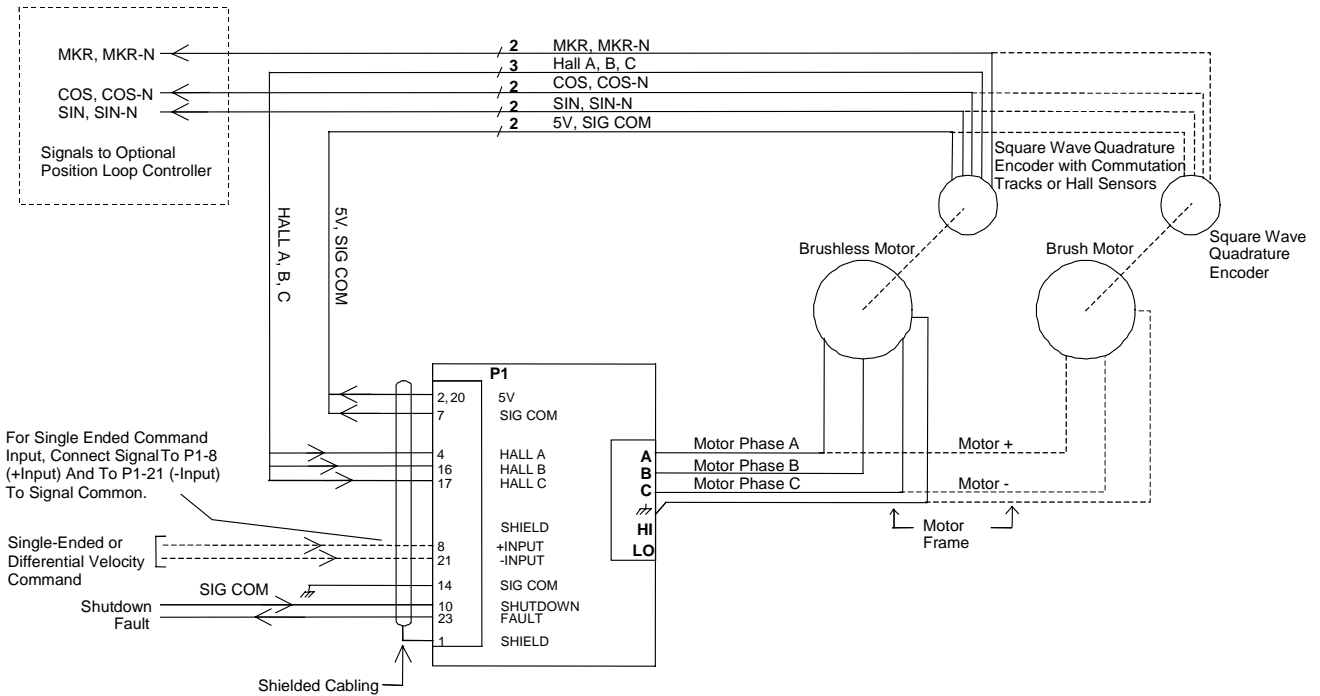

Figure 2-8. Current Command Configuration



### 2.4.3. Dual-Phase Command Configuration

This mode is used with a brushless motor only. In this configuration, the differential input, pre-amplifier, and self-commutation circuits are bypassed. The dual-phase inputs are sinusoidal and are 120° out of phase from each other. The third phase is generated by the amplifier. The dual-phase command configuration is shown in Figure 2-9. The advantage to this configuration is that it provides the smoothest possible motion.

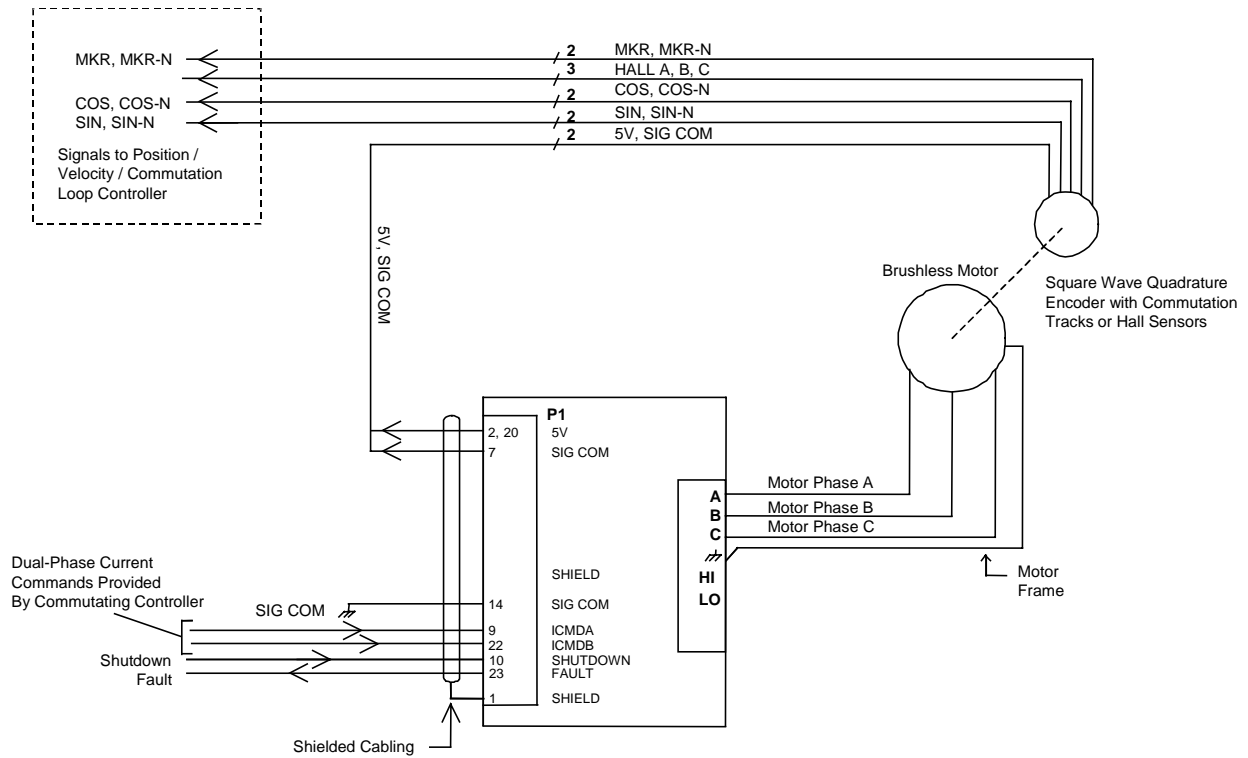

Figure 2-9. Dual-Phase Command Configuration

## 2.5. Control Connections

The BA drives can be wired into a system in one of two ways depending upon the desired mode of operation. Command signals can be referenced to velocity or torque (current) control signals. The user has access to four potentiometers, three that adjust gain while the fourth (BALance) compensates for input signal offsets. Figure 2-10 illustrates a portion of the pre-amplifier circuit that is accessible to the user for adjusting command signal gains.



For adjustments in gain roll-off, "Personality Module" **RCN1**, pins 7-10 and 8-9 are provided for the selection of the appropriate resistor/capacitor pair (factory default values are shown in Figure 2-10).

### 2.5.1. Setup - Torque Command Mode (Current)

To setup the pre-amplifier circuit for use in the torque (current command) mode, configure the BA amplifier as follows:

- Place SW1 position 10 (mode) to closed (**default**)
- Place SW1 position 9 (test) to open (**default**)
- SW1 positions 1 - 4 selects current limit, positions 5 - 8 selects RMS limit
- Set the Input Pot full CW and the Gain Pot full CCW to provide a transconductance gain of +/-10 volts for full current output. "Balance" and "Tach" have no effect.
- JP14 set to 2-3 (**default**)
- JP11 and JP13 set to 1-2 (**default**)
- JP3, JP5, JP15, and JP6 set to 1-2 (**default**) for brushless motor operation or 2-3 for brush motor operation

With this configuration, an input signal of  $\pm 10$  volts to pins **+INPUT** and **-INPUT** will produce the maximum current output signal (viewed at P1 pin 25 **ICMD**) of  $\pm 3$  volts. Switch "SW1" 1 through 4 is used to scale this  $\pm 3$ -volt signal from zero to maximum current. Refer to Figure 2-7 for torque command configuration.

### 2.5.2. Setup - Velocity Command Mode

For this mode, a velocity feedback signal is required. This feedback signal can be derived from two sources. From an analog DC tachometer that is connected to the **+TACH** pin or from an incremental encoder that is connected to the sine and cosine pins (Refer to Figure 2-7). To setup the pre-amplifier circuit for use in the velocity command mode, configure the BA amplifier as follows:

- Place SW1 position 10 (mode) to open
- Place SW1 position 9 (test) to open (**default**)
- SW1 positions 1 - 4 select current limit, positions 5 - 8 select RMS limit
- Potentiometers "INPUT", "GAIN", "BALance", and "TACH" adjust pre-amplifier gain and offset.

For most applications under the velocity command mode, the preferred starting point for setting the three gain pots is as follows:

**INPUT** pot - 1/3 CW from full CCW  
**TACH** pot - full CW  
**GAIN** pot - full CW



Starting with a zero input command signal, apply power to the amplifier. If the motor spins uncontrollably, remove power and switch the polarity of the tach input signal. If an encoder is being used, switch the sine and cosine input signals. Verify compliment signals (sin & sin-N, cos & cos-N) are of correct phasing.

Again, apply power to the amplifier. If the motor begins to oscillate, turn the **TACH** pot CCW until the oscillation stops. The **GAIN** and **TACH** potentiometers can be adjusted to provide maximum stiffness on the motor shaft.



If the desired stiffness is unattainable, the components connected to personality module **RCN1** pins 8-9 and 7-10 may be need to be changed.

The **BAL**ance pot is used to cancel any bias in the internal or external control circuit that would cause the motor to rotate when the input command signal is zero.

If the **TEST** switch is closed the effects of the **BAL**ance pot are greatly magnified. This is useful when a test bias signal is desired (for velocity or torque modes) to be applied to the amplifier without introducing an external command signal.

### 2.5.3. Setup - Dual-phase Command Mode

To setup the pre-amplifier circuit for use in the dual phase mode, configure the BA amplifier as follows:

- JP11 and JP13 are set to 2-3
- JP3, JP5, JP15, and JP6 are set to 1-2 (**default**).

This mode is used with brushless motors only. Refer to Figure 2-9 for dual phase command configuration.

## 2.6. Motor Phasing Process

When configuring the BA amplifier to run a brushless motor, the commutation signal input connections (labeled HALL A, B, C on connector P1 pins 4, 16, and 17) are necessary. These sequences and the generated output motor phase voltages (motor output connections A, B, and C) are shown in Figure 2-9. The voltages generated are made under the conditions of a positive signal placed at **+INPUT** with respect to **-INPUT** at control signal input/output connector P1. A “0” for the given HALL input indicates zero voltage or logic low, where a “1” indicates five volts or logic high.

If an Aerotech brushless motor is used with the BA amplifier, motor phase and HALL connections can be easily determined by referring to the system interconnection drawings in Figure 2-7, Figure 2-8, and Figure 2-9.



### 2.6.1. Determining Phase/Hall Sequence

For a motor with an unknown phase/hall sequence, a simple test can be performed on the motor to determine the proper connections to the BA amplifier.

Before performing the following steps, ensure that the motor leads are completely disconnected from the amplifier.



The tests outlined below do not require that the amplifier be turned on since Figure 2-11 illustrates the generated output voltage of the amplifier relative to the input Hall sequences.



The equipment needed for this test is a two-channel oscilloscope and three resistors (typically 10 Kohm, 1/2 watt) wired in a “Wye” configuration.

Connect the ends of the three resistors to motor terminals A, B, C. Use one channel of the oscilloscope to monitor motor terminal A with respect to the “Wye” neutral (eg., the point where all three resistors are connected together). Turn the shaft of the motor CCW and note the generated voltage. This voltage represents the “phase A to neutral” CEMF. With the second oscilloscope probe, determine the Hall switch that is “in phase” with this voltage. Similarly, phase B and C should be aligned with the other two Hall switches.

Refer to Figure 2-11 and note the generated output voltages of the amplifier relative to the Hall sequences applied to **HALL A**, **HALL B**, and **HALL C** connections at connector **P1**. For proper operation, the CEMF generated motor phase voltages should be aligned to the amplifier’s output generated voltage with the given Hall effect sequence shown in Figure 2-11.

If the sequence of Hall signals relative to the generated motor voltage (e.g. motor CEMF) is adhered to as illustrated in Figure 2-11; a positive (+) voltage signal applied to pin 8 (+INPUT) of connector P1 relative to pin 21 (-INPUT) of P1 or pin 19 (signal common) of P1 will produce a CCW (e.g., a negative rotation) rotation of the motor shaft as viewed from the front of the motor.

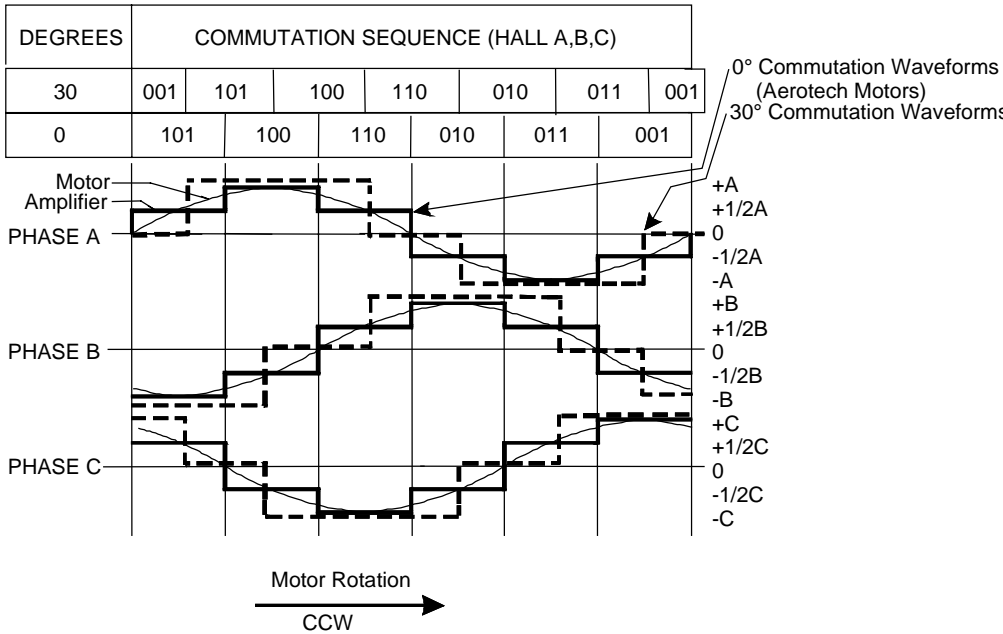

Figure 2-11. Motor Phasing

## **2.7. Current Regulator Adjustment**

The three-phase current regulator circuit is illustrated in Figure 2-12. Details to this circuit, like the “Pre-amplifier” circuit described in the previous section, are provided so that the user may optimize gains.

The BA amplifier provides three independent current regulator circuits, one for each phase of the DC brushless motor (for DC brush motors, only “Phase A” regulator is used). Regulators “A” and “B” are each provided with a current command from either the internal “six step” commutation circuit or an external current command input (**ICMDA** and **ICMDB**), depending on the settings of JP11 and JP13.

Two internally isolated circuits, one for phase “A” and the other for phase “B”, provide the motor current feedback signals.

The two current command signals as well as the two current feedback signals are each summed with the result providing the current command and current feedback signals for phase “C”.

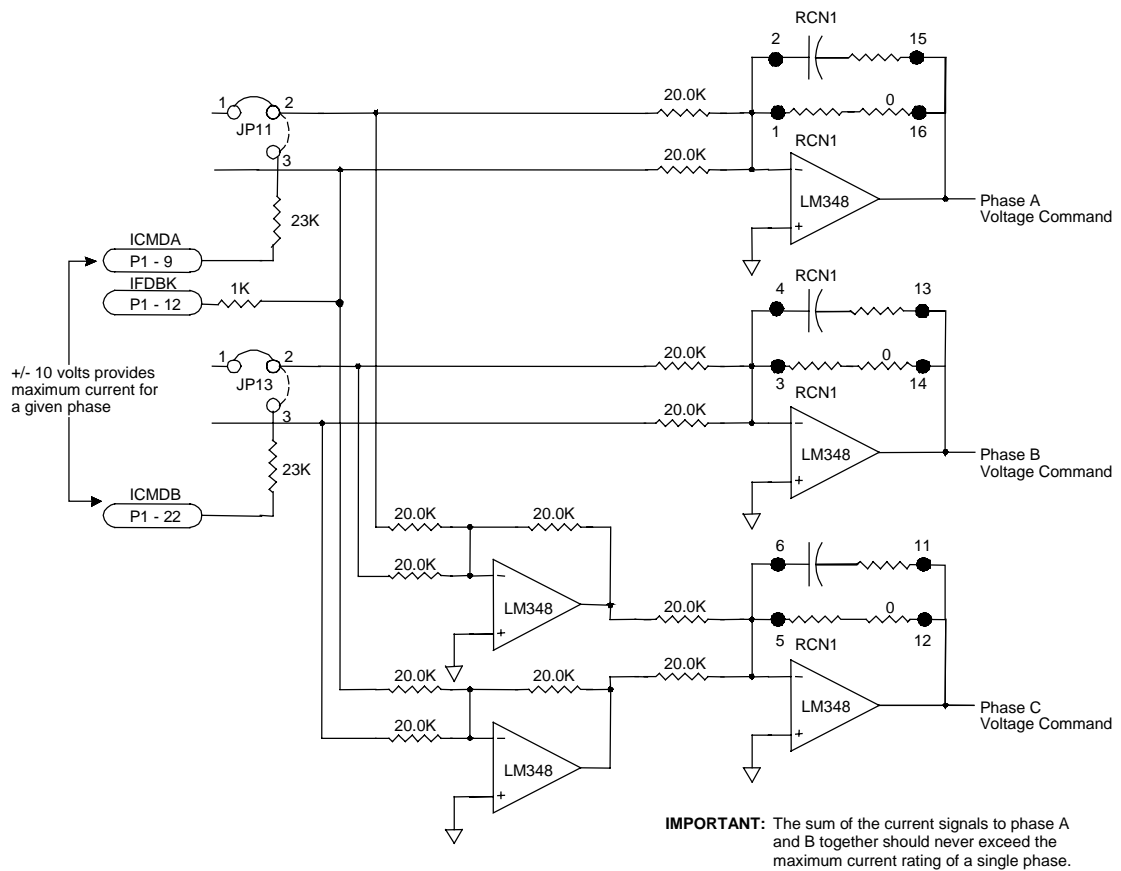

**Figure 2-12. Three-Phase Current Regulator Circuit**

Pins 1-18 and 2-17 “Personality module” **RCN1** provide gain compensation for phase “A” regulator circuit. Similar compensation is provided for phase “B” and “C” circuits as shown in Figure 2-12. The default values for these selectable components (RCN1) are shown in Figure 2-12.

Connection **IFDBK** (pin 12 of P1) is provided for monitoring phase “A” current. For DC brushless motor operation, the signal at this pin would represent motor phase “A” current. For DC brush motor operation, this signal would represent the current flowing in the motor armature.





**CHAPTER 3: TECHNICAL DETAILS**

<b>In This Section:</b>	
• Part Number and Ordering Information .....	3-1
• Electrical Specifications .....	3-2
• BA Amplifier Dimensions .....	3-5
• 40/80 VDC Power Transformers.....	3-7

**3.1. Part Number and Ordering Information**

Order information regarding part numbers, models, and packages is shown below in Table 3-1.

**Table 3-1. Ordering Information**

Amplifier Series	Output Current, Peak	Operating Bus Voltage	Internal Shunt Power Resistor
BA	10, 20, 30	40 = 28 VAC input 160 = 115 VAC input 320 = 230 VAC input	S = Shunt regulator (optional on BA10, BA20)
<b>Bus Voltage</b>			
- 40	40 VDC bus; 28 VAC input required (use TV0.3-28)		
- 80	80 VDC bus; 56 VAC input required (use TV0.3-56)		
- 160	160 VDC bus; 100-115 VAC input, direct line operation		
- 320	320 VDC bus; 230 VAC input, direct line operation (includes shunt regulator)		
<b>Options</b>			
- S	Shunt regulator		
<b>Example</b>			
BA30-320-S	15 A cont., 30 A peak servo amplifier/power supply, w/shunt regulator		
<b>Accessories</b>			
TV0.3-28	0.3 kVA autotransformer; 28 or 56 VAC out for 40 or 80 VDC bus, 115/230 VAC, 50/60 Hz input		
TV0.3-56	0.3 kVA autotransformer; 56 or 115 VAC out for 80 or 160 VDC bus, 115/230 VAC, 50/60 Hz input		
TV1.5	1.5 kVA isolation transformer; 115/230 VAC input; 28, 43, 56, 70, 115 VAC output		
TV2.5	2.5 kVA isolation transformer; 115/230 VAC input; 28, 43, 56, 70, 115 VAC output		
TV5	5 kVA isolation transformer; 115/230 VAC input; 28, 43, 56, 70, 115 VAC output		
TB	Screw terminal block for BA DB25 control connector		
LF	AC Line Filter, general noise suppression (not for CE Compliance)		
UFM	AC Line Filter Module (required for BA amplifiers to meet CE Compliance)		

### 3.2. Electrical Specifications

The electrical specifications and connector P1 pinouts for all BA drive models are listed in Table 3-2.

**Table 3-2. Electrical Specifications**

Model	Units	BA10	BA20	BA30
Output Voltage (depends on AC input voltage)	VDC	40-320 <sup>(1)</sup>		
Peak Output Current (2 sec) (current rating based on BA amplifier mounted to NEMA panel as shown in Figure 3-2)	A(pk)	10	20	30
Continuous Output Current (current rating based on BA amplifier mounted to NEMA panel as shown in Figure 3-2)	A(pk)	5	10	15
Peak Power Output (includes AC line droop)	Watts	2720	5440	8160
Continuous Power Output (includes AC line droop)	Watts	1360	2720	4080
Efficiency	%	97		
Preamp Gain (max) (velocity mode)	dB	100		
Power Amplifier Gain (current command mode)	A/V	1	2	3
Power Amplifier bandwidth	kHz	2		
PWM Switching Frequency	kHz	20		
Minimum Load Inductance	mH	0.8 @ 160 VDC bus (1 mH @ 320 VDC)		
Maximum Shunt Regulator Dissipation	Watts	40 (optional)		40
Maximum Heat Sink Temperature	deg C°	65		
Heat Sink Size (Typical)	Volume	1'x2'x0.25"		
Operating Temperature	deg C°	0 to 50		
Storage Temperature	deg C°	-30 to 85		
Weight	lb (kg)	2.5 (1.1)		
Modes of Operation (jumper selectable)	<p><b>Brushless:</b></p> <ul style="list-style-type: none"> <li>- single current command with on-board 6-step commutation from HED inputs.</li> <li>- dual phase commands with sinusoidal commutation provided by an external motion controller, third phase command is derived from the amplifier.</li> <li>- velocity command with 6-step commutation from HED inputs and velocity feedback from the tach or encoder.</li> </ul> <p><b>Brush:</b></p> <ul style="list-style-type: none"> <li>- single current command.</li> <li>- velocity command with velocity feedback from the tach or encoder.</li> </ul>			
Command Inputs	<ul style="list-style-type: none"> <li>- <b>+input-Pin 8, -input-Pin 21:</b> Differential inputs for current or velocity commands, 0 to ± 10 VDC input. “+input” (non-Inverting input) can be used in single ended fashion. A positive voltage on this input causes CCW motor rotation. “-input” (inverting input) can be used in single ended fashion. A positive voltage on this input causes CW motor rotation.</li> <li>- <b>icmda-Pin 9, icmdb-Pin 22:</b> Dual phase, ±10V input. ICMDA (current command A) and ICMDB (current command B) are jumper selectable current command inputs. They bypass the differential input, pre-amplifier, and self-commutation circuit. They are to be used with controllers that provide external velocity loop and commutation control.</li> </ul>			

<sup>(1)</sup> 40-80 VDC bus requires external transformer; 110 VAC auxiliary input for control input power

Table 3-2. Electrical Specifications Cont'd

Feedback Inputs	<ul style="list-style-type: none"> <li>- <b>Hall a-Pin 4, Hall b-Pin 16, Hall c-Pin 17:</b> Hall effect device inputs for commutation, 0 to 5 VDC, internal pull-up, 10K input. Commutation signals used with brushless motors to provide motor rotation position information to the amplifier. This allows the amplifier to steer the three phases of the motor currents in such a fashion so as to provide rotation of the motor in the desired direction at the desired speed. TTL level input.</li> <li>- <b>sine/sine-N-Pin 18, Pin 19, cosine/cosine-N-Pin 5, Pin 6:</b> Encoder inputs for velocity feedback, single ended 0 to 5VDC TTL, internal pull-up, 10K input. Sine and cosine are optionally used in conjunction with one another for deriving an electronic tachometer signal.</li> <li>- <b>+tachometer-Pin 3:</b> Tachometer input for velocity feedback, (encoder vs. tach velocity feedback is jumper selectable). A tachometer may be used in the velocity loop configuration to provide negative feedback to the amplifier. This allows the amplifier to close the servo loop and control the stability of the loop.</li> <li>- <b>tachometer-Pin 15:</b> Reference input for tachometer. This point is identical to signal common.</li> </ul>
Logic Inputs	<ul style="list-style-type: none"> <li>- <b>ilmt-Pin 24, +ilmt-Pin 11:</b> Directional current limit inputs (jumper selectable polarity). When "+ILMT" is pulled to its active state, motion in the positive direction (CW motor shaft rotation) is inhibited. When "-ILMT" is pulled to its active state, motion in the negative direction (CCW motor shaft rotation) is inhibited. TTL level input 0 to 5 VDC, internal pull-up, 10K input.</li> <li>- <b>shutdown-Pin 10:</b> Jumper selectable active high or active low input. Used to shut off power stage and therefore remove all power to the motor. TTL level input 0 to 5 VDC, internal pull-up, 10K input.</li> <li>- <b>signal ground-Pins 7 and 14:</b> Electrical reference for all control circuitry on amplifier.</li> <li>- <b>signal shield-Pin 1:</b> Connected internally to earth ground. Used for reducing electrical noise in control and feedback signals.</li> </ul>
Logic Outputs	<ul style="list-style-type: none"> <li>- <b>fault-Pin 23:</b> Jumper selectable active high or active low output. Used to indicate the status of the power stage (amplifier enabled or disabled). The fault output will go to its active state upon a power stage fault, thermal overload, RMS current limit, power supply under voltage condition, and DC bus over voltage condition. Open collector output. Requires pull-up resistor to external power supply ranging from +5V to +30V.</li> </ul>
Monitor Outputs	<ul style="list-style-type: none"> <li>- <b>fdbk-Pin 12:</b> Current feedback monitor. When running a brushless motor, this signal represents the current in the motor phase A. When running a brush motor, this signal represents the entire motor current. <math>\pm 3.7V</math> output.</li> <li>- phase A: output is 3.2 A/V for BA10, 6.5 A/V for BA 20, and 9.7 A/V for BA30.</li> <li>- <b>icmd-Pin 25:</b> Current command monitor. Representative of the current command. <math>\pm 3V</math> output. Equals peak current of amplifier 16 Amps for BA10, 20 for BA20 and 30 for BA30.</li> </ul>
Power Inputs	<ul style="list-style-type: none"> <li>- AC input: AC HI, AC LO, earth ground (<math>\neq</math>), 56-230 VAC, 50-60 Hz, single phase.</li> </ul>

**Table 3-2. Electrical Specifications Cont'd**

Auxiliary Power Outputs	<ul style="list-style-type: none"> <li>- <b>5V-Pin 20:</b> On board 5V power supply. 250 mA maximum output.</li> <li>- <b>5V-Pin 2:</b> On board 5V power supply. Pin 2 is intended for powering an encoder. Can supply up to 250mA of current.</li> </ul>
Connectors	<ul style="list-style-type: none"> <li>- control: 25 pin "D" style female.</li> <li>- power: 6 pin unpluggable screw terminal for AC input and motor output; mate provided.</li> </ul>
Potentiometers	<ul style="list-style-type: none"> <li>- Gain: adjusts preamp AC gain.</li> <li>- BALance: nulls command input DC offsets.</li> <li>- Tach: adjusts gain of tach or encoder derived velocity feedback input.</li> <li>- Input: adjusts gain of command input.</li> </ul>
DIP Switches	<ul style="list-style-type: none"> <li>- Peak current limit: 4 switches allow the user to set the peak current from 6-100% of max value.</li> <li>- RMS current limit: 4 switches allow the user to set the RMS current from 3-54% of max value.</li> <li>- Mode switch: This switch selects current or velocity mode.</li> <li>- Test: This switch selects test mode to allow the BALance pot to be used as velocity or current command.</li> </ul>
Protective Features	<ul style="list-style-type: none"> <li>- Output short circuit</li> <li>- Peak over current</li> <li>- RMS over current</li> <li>- DC bus over voltage</li> <li>- Over temperature</li> <li>- Control power supply under voltage</li> <li>- Power stage bias supply under voltage.</li> </ul>
Isolation	<ul style="list-style-type: none"> <li>- Opto and transformer isolation between control and power stages.</li> </ul>
Indicator (power)	<ul style="list-style-type: none"> <li>- LED indicates drive power.</li> </ul>
Indicator (enabled)	<ul style="list-style-type: none"> <li>- LED indicates drive enabled.</li> </ul>

### 3.3. BA Amplifier Dimensions

The outline dimensions for the BA amplifiers are shown in Figure 3-1 and Figure 3-2.

To ensure proper heat dissipation, Aerotech recommends the following procedures.

1. Use the mounting procedure shown in Figure 3-3. The wider part of the amp should be mounted to the heat sink.
2. Heat sink should be at least 2 feet<sup>2</sup> x0.25 inch thick minimum.
3. The heat sink should be free of paint or any other thermal barrier.
4. The heat sink must be flat to allow good thermal conductivity between the heat sink and the amplifier.
5. If possible, add a thermal conductivity enhancer (i.e., thermal grease between the heat sink and the amplifier).
6. Adding an external fan will remove a considerable amount of heat from the heat sink and allow the amplifier to operate at a much cooler temperature.

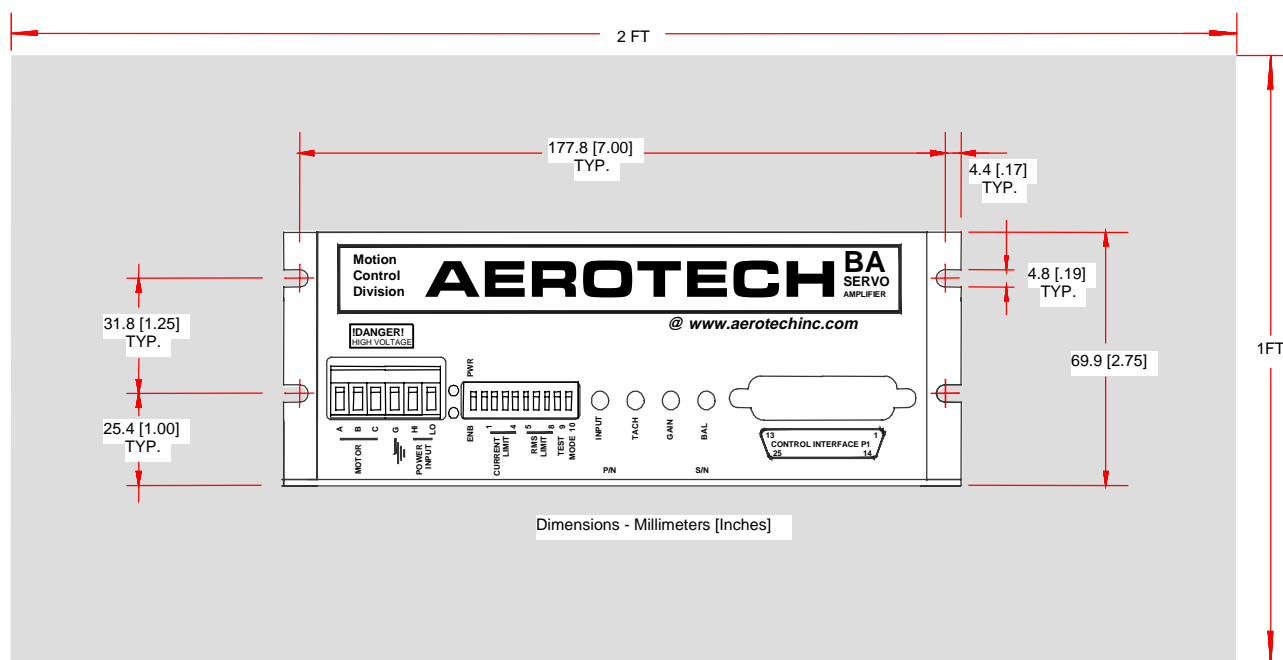

Figure 3-1. BA Amps Side View

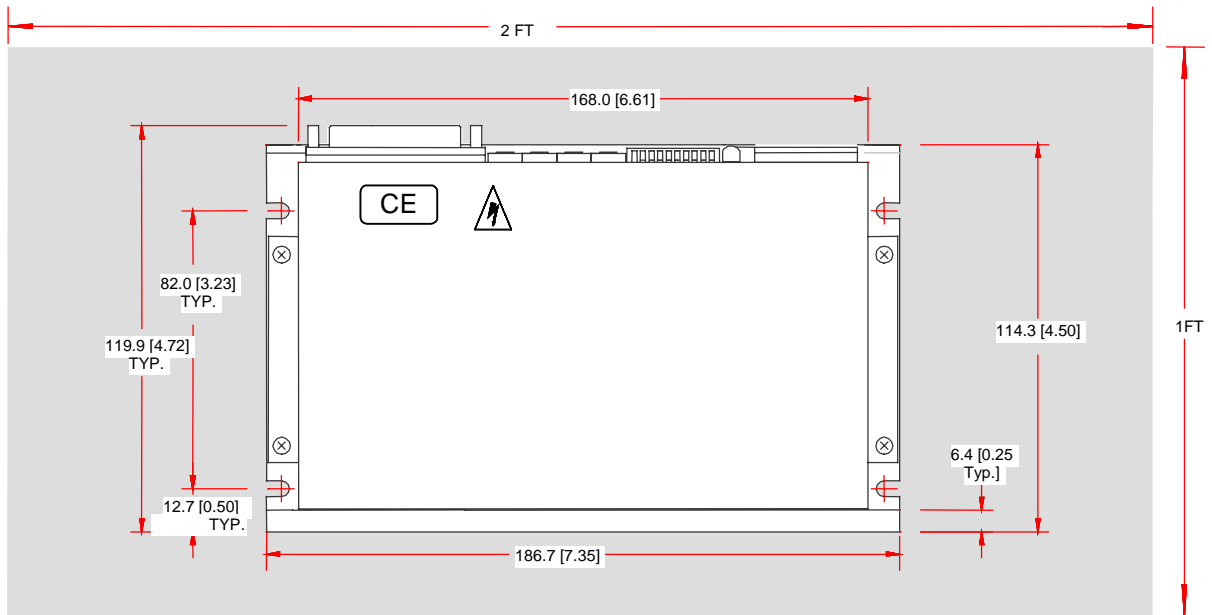

Figure 3-2. BA Amp Top View (Preferred Mounting)



It is advisable that the amplifier be mounted lying flat on a metal panel not less than two square feet for better heat dissipation. Refer to Figure 3-3.

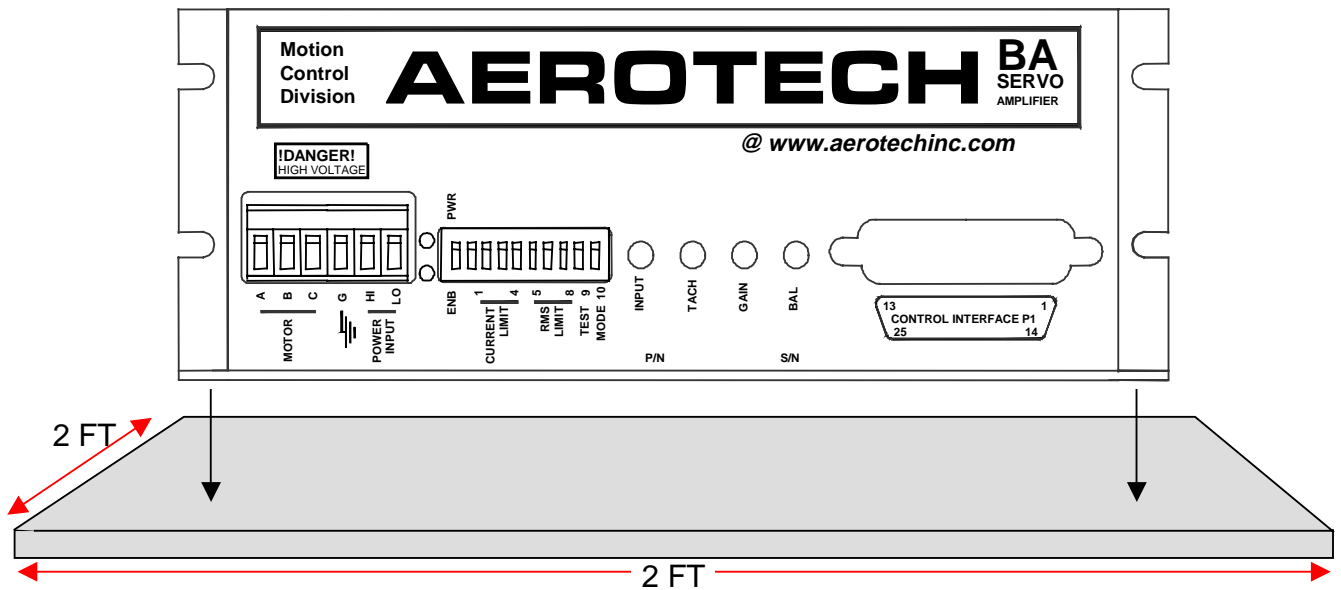

Figure 3-3. Preferred Mounting of BA Amplifiers

**3.4. 40/80 VDC Power Transformers**

The TV0.3-56 power transformer is an optional accessory to the BA amplifiers. The transformer allows the generation of 56 VAC from a 115 VAC and 230 VAC source respectively. When rectified by the BA amplifier, 56 VAC yields an 80 VDC power bus.

The TV0.3-28 power transformer is an optional accessory only available for the BA10 and BA20 amplifiers. This transformer allows for the generation of 28VAC from a 115VAC and 230VAC source, respectively. When rectified by the BA amp, 28VAC yields a 40VDC power bus.

▽ ▽ ▽





**CHAPTER 4: TROUBLESHOOTING**

**In This Section:**

- Amplifier Related Problems ..... 4-1

**4.1. Amplifier Related Problems**

This section covers symptoms, probable causes, and solutions related to BA amplifier operation. Table 4-1 lists the most common symptoms of irregular operation and the possible causes and solutions for these faults.

Before performing the tests described in Table 4-1, be aware that **lethal voltages** exist on the amplifier's PC board and at the input and output power connections. A qualified service technician or electrician should perform these tests.



**Table 4-1. Amplifier Faults, Causes, and Solutions**

Symptom	Possible Cause and Solution
"ENABLE" LED fails to energize when AC input power is applied.	<ol style="list-style-type: none"> <li>1. Insufficient input voltage. Use volt meter to check voltages at "HI" and "LO" AC input terminals.</li> <li>2. Short circuit condition at motor connections A, B, and C. Disconnect motor connections from BA amplifier and check resistance at each terminal relative to the other terminal. Resistance should read the same for all terminals (between .5 and 2.0 Ω, depending on motor).</li> <li>3. Short condition between motor connections and case of motor. Use ohm meter to check resistance between all motor leads and motor frame (ensure the motor is disconnected from amplifier). Resistance should read "infinity".</li> <li>4. Shutdown, P1-10 is not at active state for running amplifier.</li> <li>5. If amplifier faults, remove AC for 30 seconds.</li> </ol>
Brushless motor will not spin in open loop current mode.	Motor phases A, B, and C connected incorrectly relative to HA, HB, and HC hall inputs. See section 2.5 for motor phasing information.
Motor spins uncontrollably in velocity mode configuration.	Encoder (sine and cosine) signals or tach (+/-) signals are improperly connected. Swap connections to change polarity of feedback.
Amplifier faults ("ENABLE" LED deenergizes) when motor decelerates.	Bus overvoltage detected (BA10/20). This condition indicates an excessive regeneration condition. The BA10/20 requires that a shunt regulator be mounted in the unit.
Motor runs erratic in velocity mode using encoder for velocity feedback.	<ol style="list-style-type: none"> <li>1. The phase of the sine and cosine signal of the encoder is not separated by 90°. The encoder must be adjusted on the motor.</li> <li>2. Noise on the sine and cosine signals of the encoder. Use a shield or twisted pair (signal common wrapped around sine and cosine wires) cable between the motor and the BA amplifier.</li> </ol>
Amplifier Faults (Enable LED deenergizes).	<ol style="list-style-type: none"> <li>1. RMS current exceeded - turn off and then back on, run at lower current.</li> <li>2. Over temperature condition - Turn off and let amplifier cool down. Provide better ventilation.</li> <li>3. Defective on board power supply - Return for repair.</li> <li>4. Overloaded logic power supply - Remove device(s) being powered from the BA 5 V supply.</li> </ol>





**APPENDIX A: GLOSSARY OF TERMS**

<b>In This Section:</b> <ul style="list-style-type: none"><li>• Description..... A-1</li></ul>
--

**Description**

The following section provides a quick reference of terms used through this manual.

**CEMF** - Counterelectromotive Force. Voltage generated by a motor.

**DIP switch** - Dual In-line Package switch. A set of tiny toggle switches built into a housing commonly used on printed circuit boards

**Hall effect devices** - A set of three electro-optical or magnetic switches mounted on the motor that produce a sequential pattern to provide proper motor commutation.

**HED** - Hall effect device.

**IGBT** - Insulated Gate Bipolar Transistor.

**PWM** - Pulse Width Modulation.

**RMS** - Root Mean square - The effective DC value of AC voltage or current.

**TTL** - Transistor - Transistor Logic.



APPENDIX B: WARRANTY AND FIELD SERVICE

<b>In This Section:</b>	
• Laser Products.....	B-1
• Return Procedure.....	B-1
• Returned Product Warranty Determination.....	B-2
• Returned Product Non-warranty Determination.....	B-2
• Rush Service.....	B-2
• On-site Warranty Repair .....	B-2
• On-site Non-warranty Repair .....	B-2

Aerotech, Inc. warrants its products to be free from defects caused by faulty materials or poor workmanship for a minimum period of one year from date of shipment from Aerotech. Aerotech's liability is limited to replacing, repairing or issuing credit, at its option, for any products that are returned by the original purchaser during the warranty period. Aerotech makes no warranty that its products are fit for the use or purpose to which they may be put by the buyer, where or not such use or purpose has been disclosed to Aerotech in specifications or drawings previously or subsequently provided, or whether or not Aerotech's products are specifically designed and/or manufactured for buyer's use or purpose. Aerotech's liability or any claim for loss or damage arising out of the sale, resale or use of any of its products shall in no event exceed the selling price of the unit.

Aerotech, Inc. warrants its laser products to the original purchaser for a minimum period of one year from date of shipment. This warranty covers defects in workmanship and material and is voided for all laser power supplies, plasma tubes and laser systems subject to electrical or physical abuse, tampering (such as opening the housing or removal of the serial tag) or improper operation as determined by Aerotech. This warranty is also voided for failure to comply with Aerotech's return procedures.

***Laser Products***

Claims for shipment damage (evident or concealed) must be filed with the carrier by the buyer. Aerotech must be notified within (30) days of shipment of incorrect materials. No product may be returned, whether in warranty or out of warranty, without first obtaining approval from Aerotech. No credit will be given nor repairs made for products returned without such approval. Any returned product(s) must be accompanied by a return authorization number. The return authorization number may be obtained by calling an Aerotech service center. Products must be returned, prepaid, to an Aerotech service center (no C.O.D. or Collect Freight accepted). The status of any product returned later than (30) days after the issuance of a return authorization number will be subject to review.

***Return Procedure***

After Aerotech's examination, warranty or out-of-warranty status will be determined. If upon Aerotech's examination a warranted defect exists, then the product(s) will be repaired at no charge and shipped, prepaid, back to the buyer. If the buyer desires an air freight return, the product(s) will be shipped collect. Warranty repairs do not extend the original warranty period.

***Returned Product  
Warranty Determination***

***Returned Product Non-warranty Determination***

After Aerotech's examination, the buyer shall be notified of the repair cost. At such time the buyer must issue a valid purchase order to cover the cost of the repair and freight, or authorize the product(s) to be shipped back as is, at the buyer's expense. Failure to obtain a purchase order number or approval within (30) days of notification will result in the product(s) being returned as is, at the buyer's expense. Repair work is warranted for (90) days from date of shipment. Replacement components are warranted for one year from date of shipment.

***Rush Service***

At times, the buyer may desire to expedite a repair. Regardless of warranty or out-of-warranty status, the buyer must issue a valid purchase order to cover the added rush service cost. Rush service is subject to Aerotech's approval.

***On-site Warranty Repair***

If an Aerotech product cannot be made functional by telephone assistance or by sending and having the customer install replacement parts, and cannot be returned to the Aerotech service center for repair, and if Aerotech determines the problem could be warranty-related, then the following policy applies:

Aerotech will provide an on-site field service representative in a reasonable amount of time, provided that the customer issues a valid purchase order to Aerotech covering all transportation and subsistence costs. For warranty field repairs, the customer will not be charged for the cost of labor and material. If service is rendered at times other than normal work periods, then special service rates apply.

If during the on-site repair it is determined the problem is not warranty related, then the terms and conditions stated in the following "On-Site Non-Warranty Repair" section apply.

***On-site Non-warranty Repair***

If any Aerotech product cannot be made functional by telephone assistance or purchased replacement parts, and cannot be returned to the Aerotech service center for repair, then the following field service policy applies:

Aerotech will provide an on-site field service representative in a reasonable amount of time, provided that the customer issues a valid purchase order to Aerotech covering all transportation and subsistence costs and the prevailing labor cost, including travel time, necessary to complete the repair.

***Company Address***

Aerotech, Inc.  
101 Zeta Drive  
Pittsburgh, PA 15238-2897  
USA

Phone: (412) 963-7470  
Fax: (412) 963-7459



APPENDIX C: CABLE DRAWINGS

In This Section:

- Description ..... C-1

Description

The following section provides the user with 2 reference drawings for connecting Aerotech cables to the BA amplifiers.

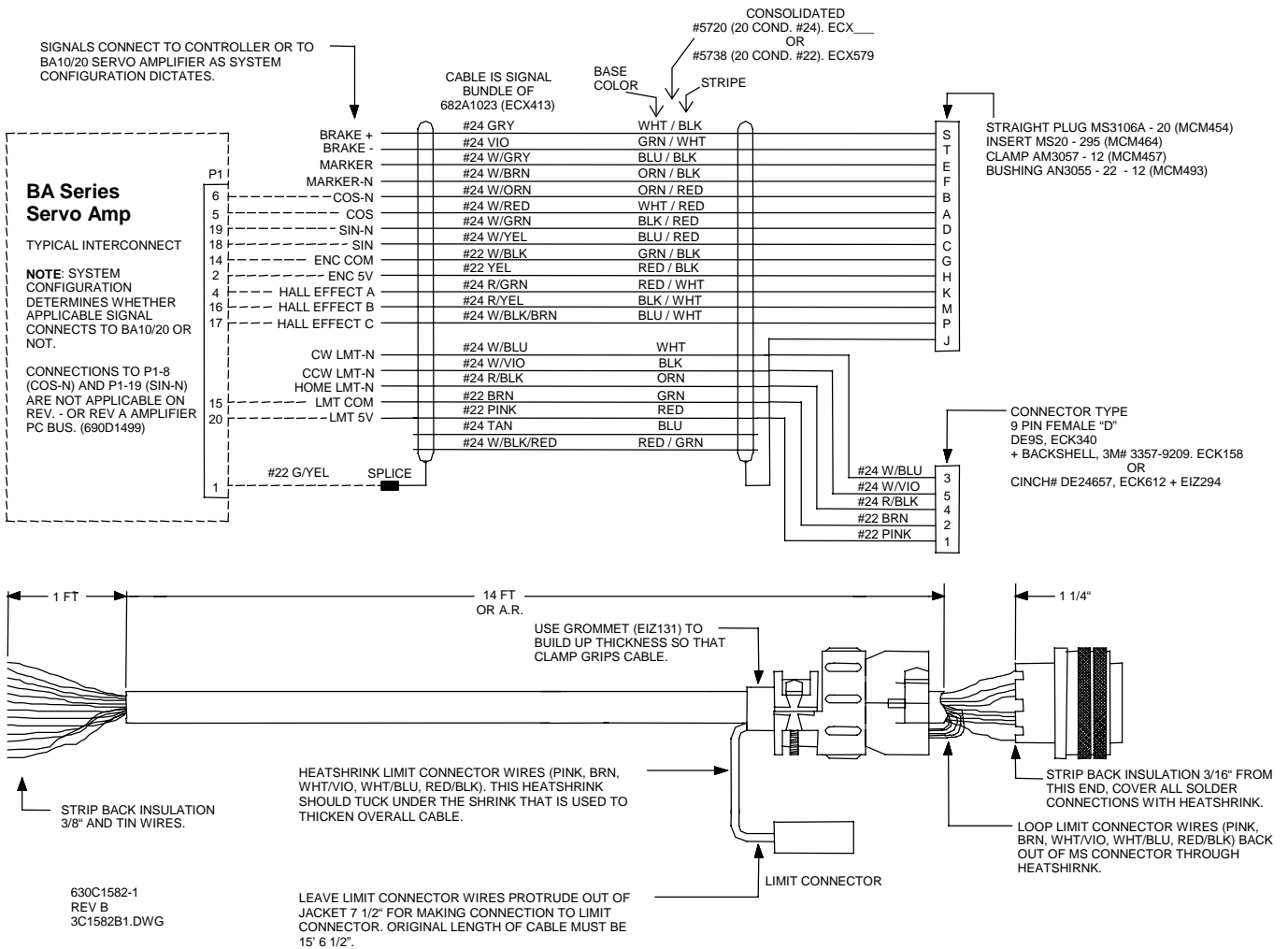

Figure C-1. BA Feedback Cable (PFC)

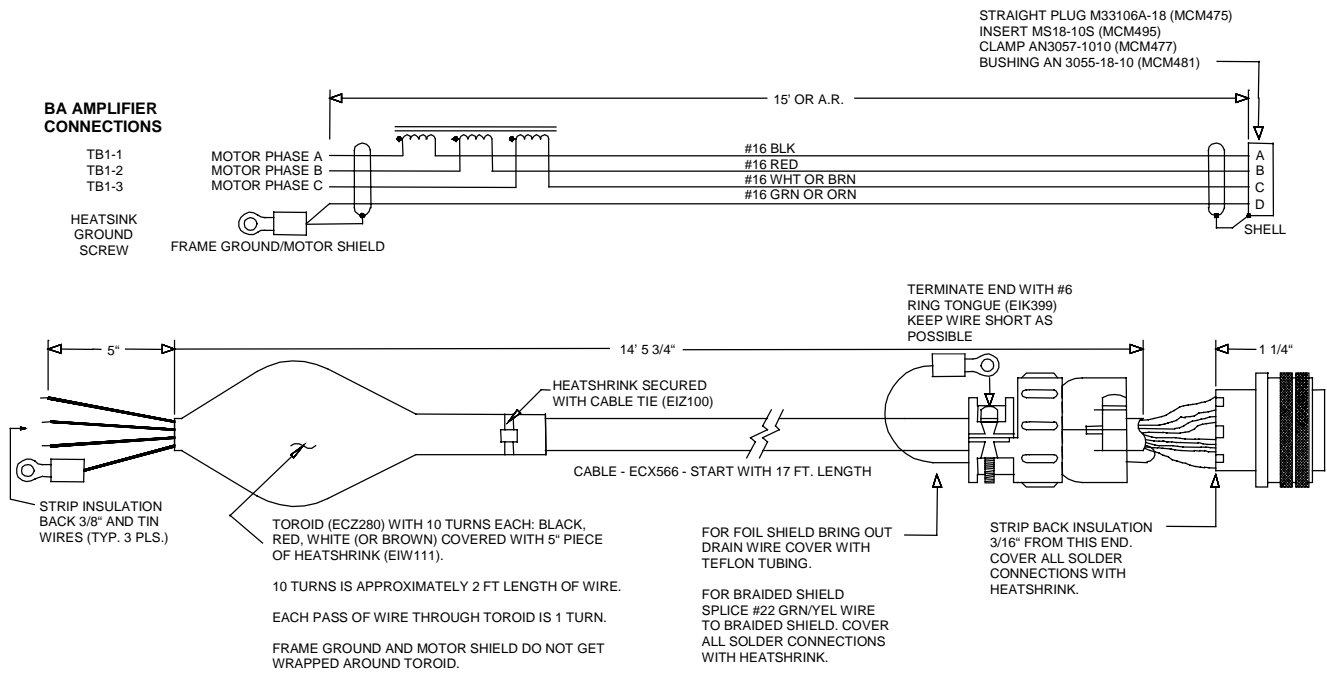

Figure C-2. BA10/20/30 Light Duty Brushless Motor Cable (PMC)





- 
- A**
- Accessories, 3-1
  - Amplifier faults, 4-1
  - Amplifier hardware, 1-4
  - Amplifier related problems, 4-1
  - applications, 1-1
- B**
- BALance pot, 1-6
  - Board assembly, 2-3
- C**
- Capacitive coupling, 2-4, 2-5
  - CEMF, A-1
  - Connector, 1-4
  - Connector P1, 1-6
  - Connector pinouts, 1-7
  - Current, 1-5
  - Current Command, 2-9, 2-10
  - Current regulator adjustment, 2-17
- D**
- Differential Input, 2-11
  - DIP switch, 1-4, 1-5, A-1
  - DIP switch functions, 1-5
  - Drive package, 1-3
  - Dual Phase Command, 2-9, 2-11
  - Dual Phase Command Mode, 2-14
- E**
- electrical specifications, 3-2
  - EMI, 2-5
  - EMI interference, 2-4
  - ENABLE LED, 1-6
  - Encoder, 2-9
  - Encoders, 1-2
  - External Controller, 2-9
- F**
- Fault conditions, 1-2
  - feedback signals, 1-2
  - Field Service Policy, B-1
- G**
- GAIN pot, 1-6
  - Grounding techniques, 2-4
- H**
- Hall effect device, 1-2, A-1
  - Hardware function, 1-4
  - Hardware overview, 1-4
- I**
- IGBT, A-1
  - INPUT pot, 1-6
  - Installation, 2-1
  - Integrated, 2-9
  - Integrated Configurations, 2-9
  - Isolation transformer, 2-8
- J**
- Jumper selections, 2-1, 2-2
- L**
- LED indicator, 1-4
  - Line filter connection, 2-7
  - Line interference, 2-7
- M**
- Mechanical drawings, 3-5
  - Mode, 1-6
  - Models, 1-2
  - Motor, 2-16
  - Motor phasing, 2-15
- N**
- Noise
    - Back-propagation, 2-7
- O**
- Operating modes, 1-2
  - Options, 1-2
  - order information, 3-1
- P**
- part number information, 3-1
  - Phase Hall sequence, 2-15
  - Position, 2-10
  - Potentiometer functions, 1-6
  - Potentiometers, 1-4, 1-6
  - Power, 1-2

Power and control connections, 2-12  
Power connections, 1-4  
Pre-Amplifier Circuit, 2-11  
Precautions, 1-11  
Product Overview, 1-1  
PWM, A-1

**R**

RMS, A-1

**S**

Safety Procedures, 1-11  
Self-Commutation, 2-11  
Shielding techniques, 2-4

**T**

TACH pot, 1-6  
Tachometer, 2-9

Test, 1-5  
Torque command mode, 2-12  
Troubleshooting, 4-1  
TTL, A-1

**V**

Velocity, 1-5, 2-9  
Velocity Command, 2-9  
Velocity command mode, 2-12  
Voltage configurations, 1-2

**W**

Warnings, 1-11  
Warranty Policy, B-1  
Wiring techniques, 2-4

▽ ▽ ▽

**REVISION HISTORY**

<p><b>In This Section:</b></p> <ul style="list-style-type: none"> <li>• Revisions ..... R-1</li> </ul>
--

**Revisions**

The following section provides the user with general information regarding the latest changes to this manual. Extensive changes, if made, may not be itemized – instead, the section or chapter will be listed with “extensive changes” in the corresponding General Information cell.

**Table R-1. Revisions**

Revision	Section(s) Affected	General Information
<b>1.6</b>	1.4.2.	Table 1-2 updated.
	2.3.2.	Figure 2-3: inrush limiter Keystone CL-10 is now obsolete, the new part number is CL-11.

▽ ▽ ▽





## READER'S COMMENTS

**BA10/20/30 Series User's Manual**  
**P/N EDA 121, February, 2002**

Please answer the questions below and add any suggestions for improving this document. Is the information:

	<u>Yes</u> _____	<u>No</u> _____
Adequate to the subject?	_____	_____
Well organized?	_____	_____
Clearly presented?	_____	_____
Well illustrated?	_____	_____
Would you like to see more illustrations?	_____	_____
Would you like to see more text?	_____	_____

How do you use this document in your job? Does it meet your needs?  
What improvements, if any, would you like to see? Please be specific or cite examples.

---

---

---

---

---

---

---

Your name \_\_\_\_\_  
Your title \_\_\_\_\_  
Company name \_\_\_\_\_  
Address \_\_\_\_\_  
\_\_\_\_\_

Remove this page from the document and fax or mail your comments to the technical writing department of Aerotech.

AEROTECH, INC.  
Technical Writing Department  
101 Zeta Drive  
Pittsburgh, PA. 15238-2897 U.S.A.  
Fax number (412) 967-6870

