



---

## Wine cellar type water cooler

Model: A1313361VB

## USER MANUAL



### WARNING

When using electrical appliances, basic safety precautions should be followed in order to reduce the risk of fire, electric shock and injury to persons or property. This manual contains important information describing how to safely set up, use and maintain your water cooler with Wine Cellar.

**SAVE THIS MANUAL FOR  
FUTURE USE**

# PRODUCT FEATURES

---

1. This water cooler can provide you Hot, Cold, room-temperature water and a Wine Cellar for food storage.
  2. Fast cooling and heating systems can provide you 80-92C hot water and 3-10C cold water with hot water capacity 4L/H and Cold water peak capacity 4L/H. The bottom Wine Cellar can chill beer, beverage, store food or make ice cubes.
  3. Unique patented safety designs: Child-safety hot tap button, no-leak bottle receptacle and double safety hot tank.
- 



Child safety hot tap button



No-leak bottle receptacle



Bottom Wine Cellar



**IMPORTANT: Do NOT Return Dispenser To Store.**  
If you have a question or problem, please contact 855-VIVA-111 for assistance.

# SAFETY PRECAUTIONS

## WARNING

**To reduce risk of injury and property damage, user must read this entire manual before assembling, installing & operating dispenser.**

**Failure to execute the instructions in this manual can cause personal injury or property damage.**

**This product dispenses water at very high temperatures. Failure to use properly can cause personal injury.**

**When operating this dispenser, always exercise basic safety precautions, including the following:**

- Prior to use, this dispenser must be properly assembled and installed in accordance with this manual.
- This dispenser is intended for water dispensing only. Do NOT use other liquids. Do NOT use for other purposes. Never use any other liquid in the dispenser other than known and microbiologically safe bottled water. Warranty is void if used for any other liquids including coffee, tea, juices, beer or wine.
- For indoor use only. Keep water dispenser in a dry place away from direct sunlight. Do NOT use outdoors.
- Install and use only on a hard, flat and level surface.
- Do NOT place dispenser into an enclosed space or cabinet.
- Do NOT operate dispenser in the presence of explosive fumes.
- Position back of dispenser no closer than 4 inches from wall and permit free airflow between wall and dispenser. There must be at least 4 inches clearance on the sides of the dispenser to permit airflow.
- Use only properly grounded outlets.
- Do not use an extension cord with your water dispenser.
- Always grasp plug and pull straight out from outlet. Never unplug by pulling on power cord.
- Do NOT use dispenser if cord becomes frayed or otherwise damaged.
- To protect against electric shock, do NOT immerse cord, plug, or any other part of cooler in water or other liquids.
- Ensure dispenser is unplugged prior to cleaning.
- Never allow children to dispense hot water without proper and direct supervision. Unplug unit to prevent unsupervised use by children.
- Service should be performed only by a certified technician. Please contact us at 888 828-1426 for assistance.
- Turn power switch(es) ON after cooler is plugged in and fill with water.

**IMPORTANT: Do NOT Return Dispenser To Store.**

**If you have a question or problem, please contact 855-VIVA-111 for assistance.**

## SAFETY PRECAUTIONS ---Electrical Requirements

### **▲ WARNING**

#### **Electrical Shock Hazard**

Plug into a grounded 3 prong outlet.  
Do not remove ground prong.  
Do not use an adapter.  
Do not use an extension cord.  
Failure to follow these instructions can result in death,  
fire, or electrical shock.

A 120 volt, 60 Hz., AC only, 15- amp, fused electrical supply is required. A time-delay fuse or circuit breaker is recommended. Do not overload the circuit, provide separate circuit, if required, to serve only this appliance.

This water cooler is equipped with a power supply cord having a 3 prong grounding plug.

To minimize possible shock hazard, the cord must be plugged into a mating, 3 prong, grounding-type outlet, grounded in accordance with local codes and ordinances, a mating outlet is not available, it is the personal responsibility and obligation of the customer to have the properly grounded outlet installed by a qualified electrician.

If codes permit and a separate ground wire is used, it is recommended that a qualified electrician determine that the ground path is adequate.

Do not ground to a gas pipe.

Check with a qualified electrician if you are not sure the water cooler is properly grounded.

Do not have a fuse in the neutral or ground circuit.

### **GROUNDING INSTRUCTIONS**

For a grounded, cord-connected water cooler:

This water cooler must be grounded. In the event of a malfunction or breakdown, grounding will reduce the risk of electrical shock by providing a path of least resistance for electric current. This water cooler is equipped with a cord having an equipment-grounding conductor and a grounding plug. The plug must be plugged into an appropriate outlet that is properly installed and grounded in accordance with all local codes and ordinances.

### **▲ WARNING**

Improper connection of the equipment-grounding conductor can result in a risk of electric shock. Check with a qualified electrician or serviceman if you are in doubt as to whether the appliance is properly grounded.

Do not modify the plug provided with the appliance-if it will not fit the outlet, have a proper outlet installed by a qualified electrician.

**“Please make sure that ELECTRICAL OUTLET IS PROPERLY WIRED TO CORRECT SIZED CIRCUIT BREAKER OR FUSE AND PROPERLY GROUNDED. MUST BE WIRED TO HAVE CORRECT POLARITY.**

**IMPORTANT: Do NOT Return Dispenser To Store.**

If you have a question or problem, please contact 855-VIVA-111for assistance.

# TABLE OF CONTENTS

Product Features .....	2
Safety Precautions .....	3
Key Information for Future Use .....	5
Specifications .....	6
Parts & Features .....	6
Electrical diagram.....	7
Assembly .....	8
Proper Care & Cleaning .....	9
Operation .....	10
Troubleshooting .....	13
Limited Warranty .....	14

## KEY INFORMATION FOR FUTURE USE



Please register your dispenser immediately at **[www.electrotemp.com](http://www.electrotemp.com)**

For future support please record your serial number (located on label on back of dispenser) and date purchased. Staple your receipt to manual.

You will need this information to obtain warranty service.

Product	<b>Wine cellar Type Water Cooler</b>
Model Number	<b>A1313361VB</b>
Serial ID Number	_____
Date of Purchase	_____

**IMPORTANT: Do NOT Return Dispenser To Store.**  
 If you have a question or problem, please contact 855-VIVA-111 for assistance.

# SPECIFICATIONS



Voltage/frequency/current	120V/ 60Hz/ 5 A
Refrigerant Type	R-134A
Cooling Power	100 W
Hot Water Power	425 W
Cold water capacity / Hour	1Gallon / 3.79L (<10°C)
Hot water capacity / Hour	1Gallon / 3.79L (>80°C)
Wine cellar temperature	3°C~20°C / 37.4°F - 68°F
Wine cellar volume	5.94 Gallon / 22.5L
Dimensions	102.8 cm H x 32 cm W x 38.2 cm D 40.5 inch H x 12.6 inch W x 15 inch D
Net Weight	48.1lbs / 21.8Kg

# PARTS & FEATURES

- Tap button:Hot Water ①
- Child Safety Lock ②
- Tap button:Room Temp Water ③
- Tap button:Cold Water ④
- Tap:Hot Water ⑤
- Tap:Room Temp Water ⑥
- Tap: Cold Water ⑦
- LED Night Lights ⑧
- Drip Tray ⑨
- Door ⑩
- Hot Power Switch ⑪
- Power Cord ⑫
- Carry Handle ⑬
- Drain Plug ⑭
- LCD display ⑮

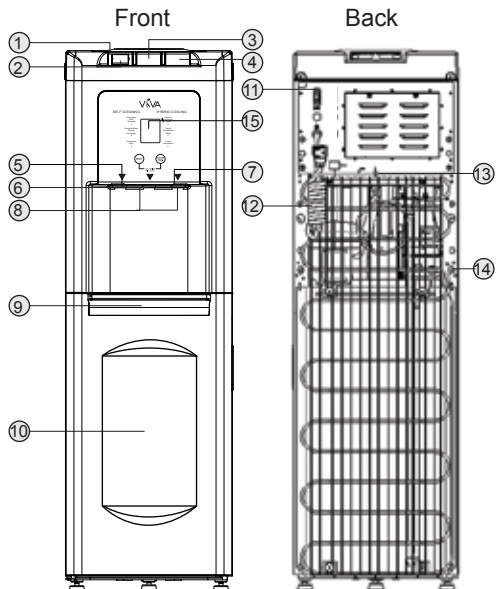

**IMPORTANT: Do NOT Return Dispenser To Store.**

If you have a question or problem, please contact 855-VIVA-111for assistance.

# Electrical diagram

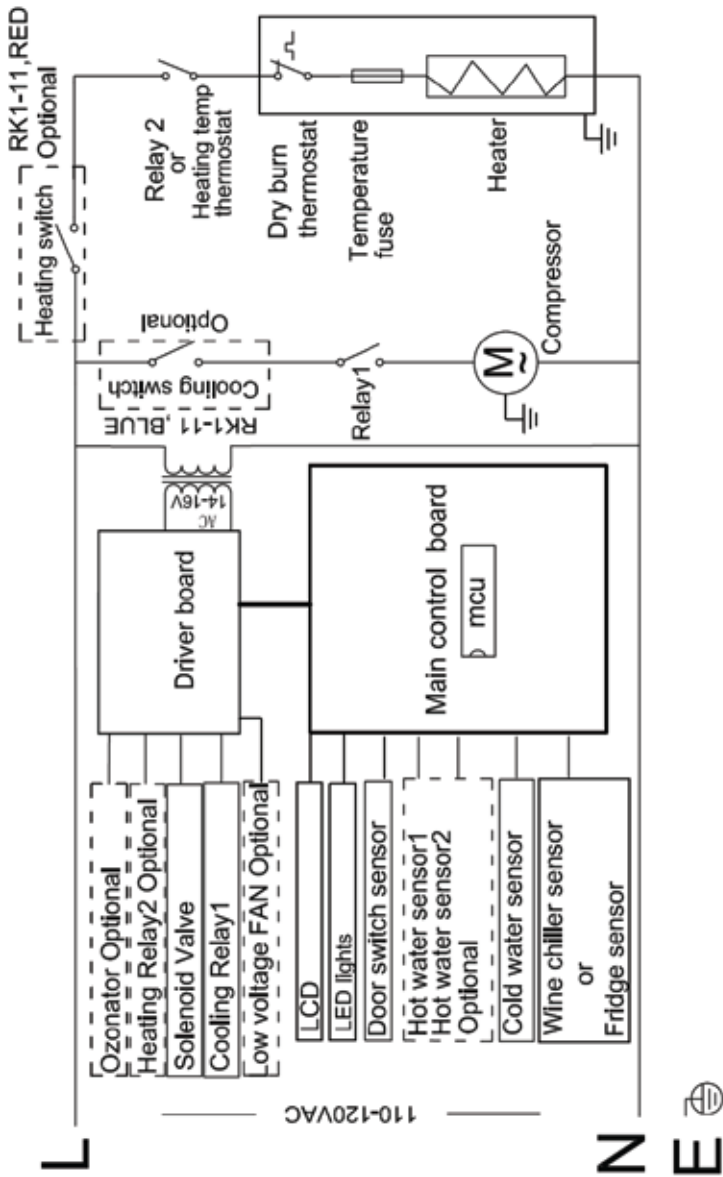

**IMPORTANT: Do NOT Return Dispenser To Store.**  
 If you have a question or problem, please contact 855-VIVA-111 for assistance.

# ASSEMBLY

## ⚠ WARNING

Keep plastic bags away from children.

1. Remove dispenser from packaging.
2. Unpack drip tray and insert into dispenser.

As shown in figure 

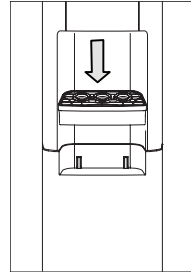



3. Remove the bottle receptacle from packaging and insert into Stainless cold tank

As shown in figure 

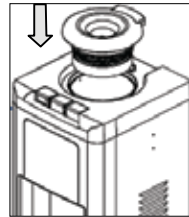
4. Properly dispose all of packaging.



5. Find a location for your water cooler that is protected from direct sunlight and other sources of heat. Like all other water coolers, prolonged exposure to sunlight will discolor the plastic exterior
6. Place the cooler on a flat, level surface
7. To ensure the cooler is level, adjust its feet by rotating them, adjusting 4 feet first and slightly adjust 5th feet last. As show in figure 
8. Make sure the back of your water cooler is at least 4 inches away from the wall. Keep a minimum distance of at least 4 inches on each side of your water cooler free. Keep items such as papers, clothing, and furniture at a safe distance. As show in figure 
9. This cooler is designed and built for indoor use only. Room temperature should not exceed 37C/99F.

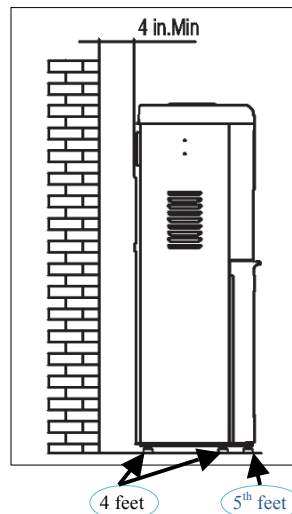

**IMPORTANT: Do NOT Return Dispenser To Store.**

If you have a question or problem, please contact 855-VIVA-111 for assistance.



# PROPER CARE & CLEANING :

## General Cleaning

Perform :As needed

Time Required:5minutes

Note :Do Not use abrasive material or chemical cleaners



1. Unplug power cord from wall outlet.
2. Clean cabinet surfaces with a soft cloth and warm soapy water.
3. Wipe dust from back of dispenser to improve efficiency.
4. Remove drip tray assembly by sliding it forward. Remove cover. Place tray and cover in dishwasher or wipe parts clean with a soft cloth and warm soapy water.

## SANITIZING

In order to remove the dust produced in the course of transportation. Prior to use the water cooler. It should be cleaned

Perform: Every 3 months or whenever an off-taste occurs.

Time Required: 15 minutes.

1. Place the cooler upright.
2. Make a sanitizing solution of 1.5 gallons of tap water and 3 tablespoons of unscented household bleach in to a 5 gallon bottle.
3. put the bottle with cleaning liquid on the water cooler, As shown in figure 
4. Press down the cold,hot tap button,take out 0.5 gallons
5. water for cleaning the taps.
6. Place a 2 gallon or larger bucket under the drain plug in the rear of the dispenser,As show in figure 
7. Remove drain cap and silicon plug. Cold water will immediately flow into the bucket. Several seconds later hot water will dispense

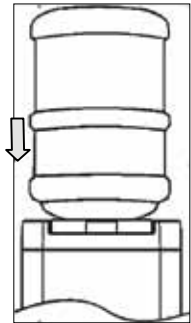

### CAUTION

8. Remove remaining water from reservoir by dispensing from the cold tap into a pitcher
9. Repeat step 2-12 with clean water,until water become clean and odorless.
10. Once unit has drained, replace silicon plug and drain cap.

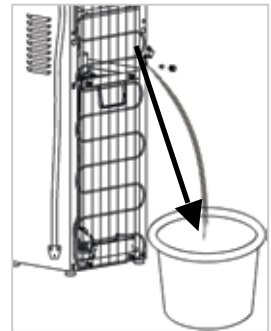

**IMPORTANT: Do NOT Return Dispenser To Store.**

If you have a question or problem, please contact 855-VIVA-111for assistance.

# Operation

**Not : in order to prevent compressor damage, the water cooler should stand upright for at least 4 hours. Make sure the water cooler is full filled with water before plugging in power.**

1. Tear off the plastic seal or label wrapping outside of the bottle cap, Place down the water bottle into the bottle receptacle vertically, the bottle cap will be pierced by the probe and bubbles will pop up while filling water into the cooler.
2. Press down the cold and hot tap button until the water comes out from both taps.
3. Plug power cord into a grounded power socket, the compressor will start cooling, turn on the hot switch and hot tank start working, it may take 60 minutes to cool water temperature down to icy cold and 15-20 minutes to heat up the hot water.
4. To change a new water bottle, remove the bottle vertically up then repeat the step 1 and step 2.

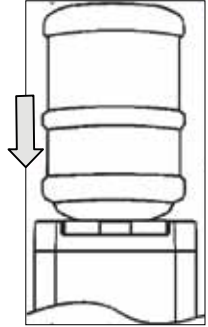

## How to use digital display panel:

1. View of display panel

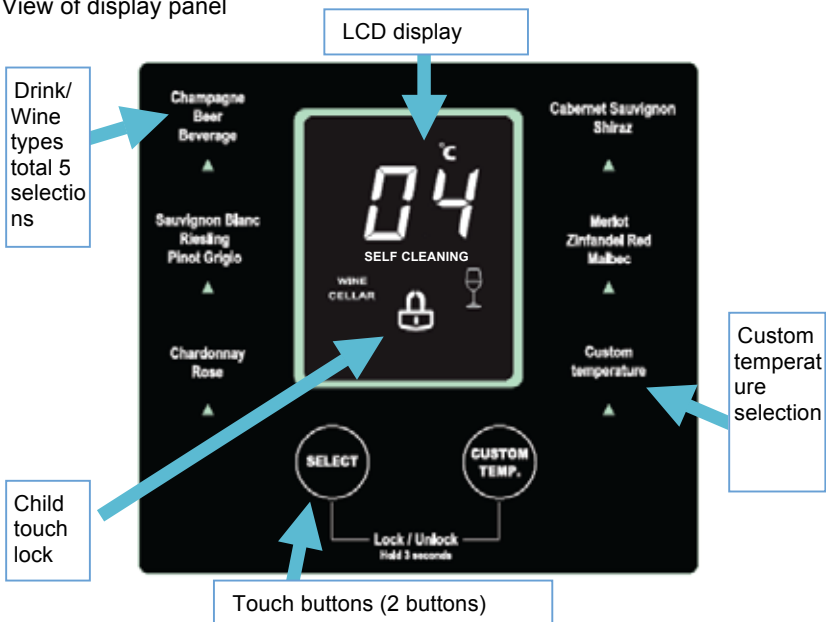

**IMPORTANT: Do NOT Return Dispenser To Store.**

If you have a question or problem, please contact 855-VIVA-111 for assistance.

## 2. System default temperature table

Drink/Wine name	Default temperature
Champagne/Beer/Beverage	4°C
Sauvignon Blanc/Riesling/Pinot Grigio	6°C
Chardonnay/Rose	8°C
Cabernet Sauvignon/Shiraz	10°C
Merlot/Zinfandel Red/Malbec	12°C
Custom temperature	3°C~20°C selectable

The default drink selected when plug in: **Champagne/Beer/Beverage**

**Note: The system will go back to default setting when power failed.**

## 3. LCD display

The temperature displayed is the storage temperature for drink/wine, but not the dynamic actual temperature inside the Wine Cellar.

The Lock icon is open means settings can be adjusted, if lock icon is closed means setting can not be changed to prevent naughty child changing the settings.

The glass cup icon lights up means the Wine Cellar is working.



## 4. Customer setting

Before making setting, unlock the child-safety lock by pressing the “SELECT” and “CUSTOM TEMP” concurrently for 3 seconds. Then start to select wine or make custom temperature setting.

The store temperature will be displayed and the LED light which is below the wine name will flash when different wine selected like the pictures showing below (5 kinds of drink/wine selectable):

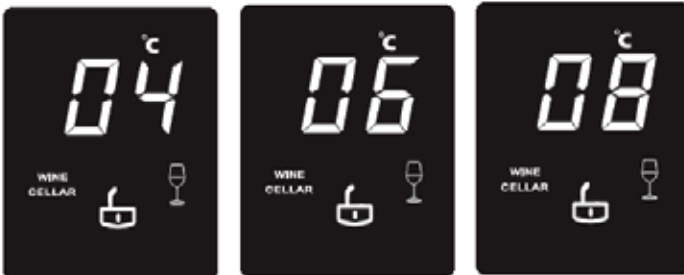

**IMPORTANT: Do NOT Return Dispenser To Store.**

If you have a question or problem, please contact 855-VIVA-111 for assistance.



### How to make “custom temperature” setting:

Press the “CUSTOM TEMP” button for by single touch, the LED light below “Custom temperature” will flash, and LCD will flash 3°C, To adjust the temperature you want by touching “SELECT” button. Note: the adjust range is from 3°C-20°C.

When setting is done, system will save automatically and display will go back to default display without touching any button.

LCD display example is showing here:



### How to use the child-safety hot water tap

First press down the child safety lock, and then press down the button without releasing the child-safety lock  
As shown in figure

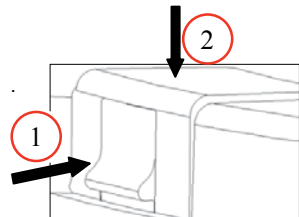

### Wine cellar door

The wine cellar door must be closed tightly to make sure the wine cellar work properly.

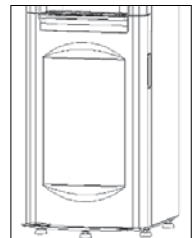

**IMPORTANT: Do NOT Return Dispenser To Store.**

If you have a question or problem, please contact 855-VIVA-111 for assistance.

# TROUBLESHOOTING

SYMPTOMS	POSSIBLE REASONS	HOW TO SOLVE
No hot water	<ol style="list-style-type: none"> <li>1. There is no power or not plugged in.</li> <li>2. Heating switch is "OFF".</li> <li>3. Plugged into power while water dispenser is not filled with water and the protection thermostat of the heater is cut off due to dry burnt.</li> </ol>	<ol style="list-style-type: none"> <li>1. Plug in power.</li> <li>2. Turn on switch</li> <li>3. Wait for about one hour until the thermostat reset itself.</li> </ol>
No cold water	<ol style="list-style-type: none"> <li>1. There is no power or not plugged in.</li> <li>2. First time cooling takes about 1 hour.</li> <li>3. Compressor cooling system problem if there is no cold water and Wine Cellar doesn't cool after one hour running.</li> </ol>	<ol style="list-style-type: none"> <li>1. Plug in power.</li> <li>2. Wait for one hour</li> <li>3. Check if the condenser(at the back) is hot or not by hand. If it is not hot call for service.</li> </ol>
Wine cellar does not cool	<ol style="list-style-type: none"> <li>1. Wine cellar door is not closed properly.</li> <li>2. Too much cold water used, the cooling system is making cold water.</li> <li>3. Compressor cooling system problem if there is no cold water and Wine Cellar doesn't cool.</li> </ol>	<ol style="list-style-type: none"> <li>4. Close door tightly</li> <li>5. Wait for a few hours.</li> <li>6. Check if the condenser(at the back) is hot or not by hand. If it is not hot call for service.</li> </ol>
Water leakage	<ol style="list-style-type: none"> <li>1. Water bottle is broken or has crack(s).</li> <li>2. Condensate water flows out from the Wine Cellar</li> </ol>	<ol style="list-style-type: none"> <li>1. Change a new good water bottle.</li> <li>2. Clean up the Wine Cellar with soft cloth.</li> </ol>
Noisy	<ol style="list-style-type: none"> <li>1. Water cooler is not well placed</li> <li>2. Co-vibration</li> </ol>	<ol style="list-style-type: none"> <li>1. Please cooler on flat floor.</li> <li>2. If press the condenser (at back) by hand and the noise disappear, put a soft piece under the condenser to eliminate the co-vibration.</li> </ol>
No water is coming from the taps	<ol style="list-style-type: none"> <li>1. Water bottle is empty.</li> <li>2. The seal on the bottle cap is not removed and it is stuck to the bottle receptacle probe.</li> <li>3. Big ice blocks the water passage.</li> </ol>	<ol style="list-style-type: none"> <li>1. Change a new water bottle.</li> <li>2. Make sure to remove the label or sticker on the bottle cap.</li> <li>3. The ice inside the cold water tank is too big to block the water passage, call for service.</li> </ol>

**IMPORTANT: Do NOT Return Dispenser To Store.**

If you have a question or problem, please contact 855-VIVA-111 for assistance.

# LIMITED WARRANTY

---

Electrotemp Technologies Inc., (“Vendor”) warrants to the original purchaser of this dispenser, and to no other person, that if this dispenser is assembled and operated in accordance with the printed instructions accompanying it, then for a period of ONE (1) years from the date of purchase, all parts in such dispenser shall be free from defects in material and workmanship. Vendor may require reasonable proof of your date of purchase from an authorized retailer or distributor. Therefore, you should retain your sales slip or invoice. The Limited Warranty shall be limited to repair or replacement of parts, which prove defective under normal use and service and which Vendor shall determine in its reasonable discretion upon examination to be defective. Before returning any parts, you should contact Vendor’s Customer Service Department using the contact information listed below. If Vendor confirms, after examination, a defect covered by this Limited Warranty in any returned part, and if Vendor approves claim, Vendor will replace such defective part without charge. If you return defective parts, transportation charges must be prepaid by you. Vendor will return replacement parts to original purchaser, freight or postage prepaid.

The Limited Warranty does not cover any failures or operating difficulties due to accident, abuse, misuse, alteration, misapplication, improper installation or improper maintenance or service by you or any third party, or failure to perform normal and routine maintenance on the dispenser, as set out in the User’s Manual. In addition, the Limited Warranty does not cover damages to the finish, such as scratches, dents, discoloration or rust after purchase.

The Limited Warranty is in lieu of all other express warranties. Vendor disclaims all warranties for products that are purchased from seller other than authorized retailers or distributors. AFTER THE PERIOD OF THE ONE (1) YEARS EXPRESS WARRANTY, VENDOR DISCLAIMS ANY AND ALL IMPLIED WARRANTIES, INCLUDING WITHOUT LIMITATION THE IMPLIED WARRANTIES OF MERCHANTABILITY AND FITNESS FOR A PARTICULAR PURPOSE. FURTHER, VENDOR SHALL HAVE NO LIABILITY WHATSOEVER TO PURCHASER OR ANY THIRD PARTY FOR ANY SPECIAL, INDIRECT, PUNITIVE, INCIDENTAL, OR CONSEQUENTIAL DAMAGES. Vendor assumes no responsibility for any defects caused by third parties. This Limited Warranty gives the purchaser specific legal rights; a purchaser may have other rights depending upon where he or she lives. Some jurisdictions do not allow exclusion or limitation of special, incidental or consequential damages, or limitations on how long a warranty lasts, so the above exclusion and limitations may not apply to you.

Warranty is void if electrical outlet is improperly wired to incorrectly sized circuit breaker or fuse, if not grounded properly, or wires do not have correct polarity.

Electrotemp Technologies Inc.  
406 Watline Avenue  
Mississauga, Ontario, L4Z-1X2  
888-828-1426  
[www.electrotemp.com](http://www.electrotemp.com)

**IMPORTANT: Do NOT Return Dispenser To Store.**

If you have a question or problem, please contact 855-VIVA-111for assistance.

名称：酒柜说明书A1313361VB(网销)-English

图号：5M007963X1

技术要求：

- 1.尺寸：143\*210mm
- 2.单色印刷
- 3.产品符合Rosh要求
- 4.批量生产前一定要样品确认  
不得擅自更改图纸

设计：

审核：

批准：