

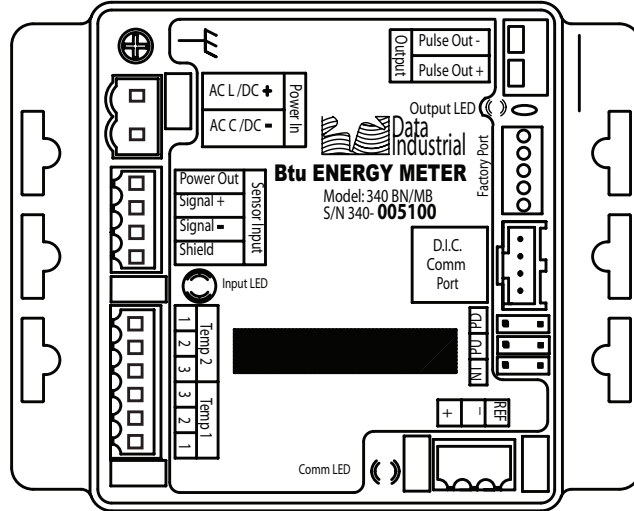

Data Industrial® 340 BN/MB BTU Energy Transmitter

Hydronic Energy Transmitter with RS-485 BACnet® and Modbus® and Scaled Pulse Output



CONTENTS

INTRODUCTION	5
INSTALLATION	5
Mechanical Installation.	5
Location	5
Surface Mount Installation	6
Wall Mounting	6
DIN Rail Mounting	7
Temperature Sensor Installation	7
Direct Insert	7
Thermowell.	7
Hot Tap	8
Electrical Installation	8
Power Supply Wiring	9
Sensor Wiring	10
Series 200	10
SDI Series	10
Other Flow Sensors	10
Temperature Element Wiring	11
Thermistors.	11
Resistance Temperature Detectors (RTDs)	11
Pulse Output Wiring.	11
Connecting the RS-485 Buss	12
Communications Cable Wiring	13
PROGRAMMING	14
Connecting Via DIC COM Port	14
Flow Sensor Section.	18
Temperature Sensor Section	18
Energy Calculation	19
Filter Coefficients	19
Pulse Output	19
RS-485 Network Configurations	20
RS-485 Network Configuration – Pulse Out Only	20
RS-485 Network Configuration – Modbus.	20
RS-485 Network Configuration – BACnet	22
RS-485 Network Test	24
Factory Default Settings	25

SPECIFICATIONS 26

 POWER 26

 FLOW SENSOR INPUT 26

 Pulse type sensors 26

 Sine wave sensors. 26

 TEMPERATURE SENSOR INPUT 26

 PULSE OUTPUT 26

 OPERATING TEMPERATURE 26

 WEIGHT 26

 SENSOR CALIBRATION 26

 UNITS OF MEASURE 26

 Flow measurement 26

 Energy measurement 26

 PROGRAMMING 26

INTRODUCTION

The Data Industrial 340 BN/MB Btu Energy Transmitter from Badger Meter is an economical, compact device for hydronic sub-metering applications. It uses an RS-485 connection for Modbus[®] and BACnet communication protocols and a solid state switch for pulse output representing either flow or energy.

The 340 BN/MB Btu Energy Transmitter calculates thermal energy by integrating the liquid flow in a closed pipe system and the differential temperature between the supply and return. The 340 BN/MB Btu Energy Transmitter requires one flow sensor and two temperature sensors.

The temperature sensors can be two-wire 10k Ω Type II Thermistors or 100 or 1000 Ω RTDs that follow the IEC 751 curve.

The flow input may be provided by many of the Data Industrial line of flow sensors and other manufacturers' devices that generate pulse or sine waves.

The onboard microprocessor and digital circuitry make precise measurements and produce accurate drift-free output. The 340 BN/MB Btu Energy Transmitter is programmed using the Badger Meter Windows[®] software and a Data Industrial Series A301 programming cable. Calibration information for the flow sensor, units of measurement, communication protocol settings and output scaling may be downloaded prior to installation or in the field.

The RS-485 Modbus settings include Baud Rate, Address and RTU/ASCII.

The RS-485 BACnet is an MS/TP slave device and includes Address, Baud Rate, Device Name, Device Instance Number and Max Master Valve.

While the unit is connected to a PC or laptop computer, real-time flow rate, flow total, both temperature readings, energy rate and energy total are available.

The 340 BN/MB Btu Energy Transmitter features three LEDs to indicate flow sensor activity, RS-485 activity and pulse output.

The 340 BN/MB Btu Energy Transmitter has an isolated solid state switch closure that is user programmed for units of energy or flow. The output pulse width is adjustable from 10 ms to 5 sec.

The 340 BN/MB Btu Energy Transmitter operates on AC or DC power supplies ranging from 12 to 24 volts.

The compact cast epoxy body measures 3.65 x 2.95 inches (93 x 75 mm) and can be easily mounted on panels, DIN rails or enclosures.

INSTALLATION

Mechanical Installation

The 340 BN/MB Btu Energy Transmitter may be surface mounted onto a panel, attached to DIN rails using adapter clips or wall mounted using two optional enclosures.

Location

Although the 340 BN/MB Btu Energy Transmitter is encapsulated, all wiring connections are made to exposed terminals. The unit should be protected from weather and moisture in accordance with electrical codes and standard trade practices.

In any mounting arrangement, the primary concerns are ease of wiring and attachment of the programming cable.

The unit generates very little heat so no consideration needs to be given to cooling or ventilation.

Surface Mount Installation

The 340 BN/MB Btu Energy Transmitter may be mounted to the surface of any panel using double-sided adhesive tape or by attaching fasteners through the holes in the mounting flanges of the unit.

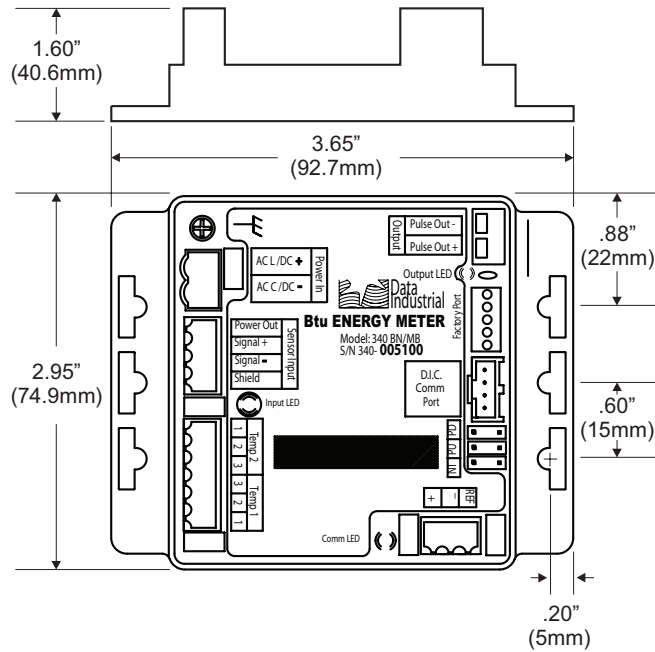

Figure 1: 340 BN/MB Dimensions

Wall Mounting

Optional metal and plastic enclosures are available to mount the 340 BN/MB Btu Energy Transmitter to a wall when no other enclosure is used. The enclosure is first attached to the wall using fasteners through its mounting holes.

After wiring, the transmitter may be attached to the enclosure with the terminal headers facing in using the slots in the mounting flanges. As an alternate mounting arrangement, the 340 BN/MB Btu Energy Transmitter may be fastened to the box cover using double-sided adhesive tape.

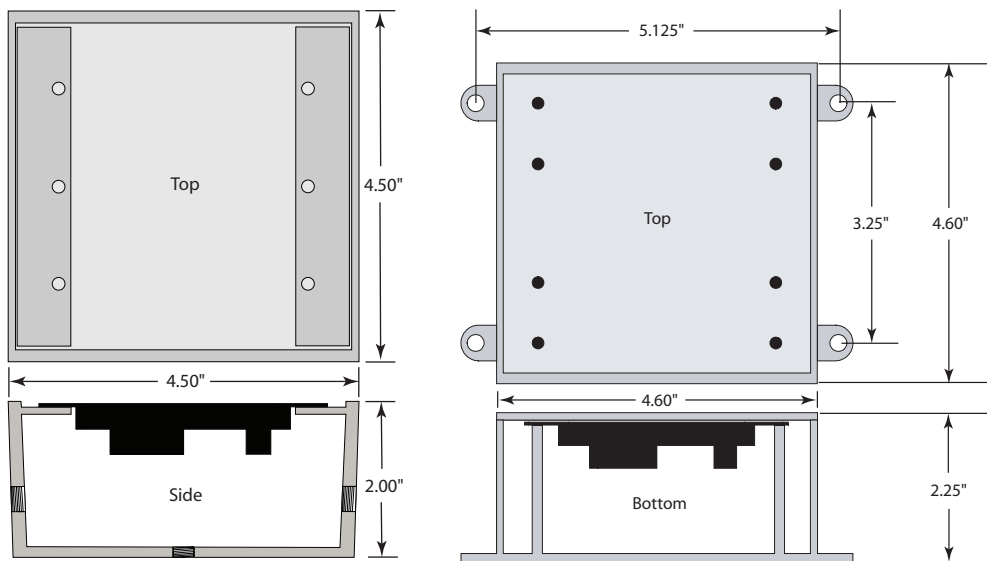

Figure 2: 340 BN/MB Metal (left) and Plastic (right) Box Dimensions

DIN Rail Mounting

Optional clips snap onto the mounting flanges allowing the 340 BN/MB Btu Energy Transmitter to be attached to DIN 15, 32, 35 mm DIN rail systems.

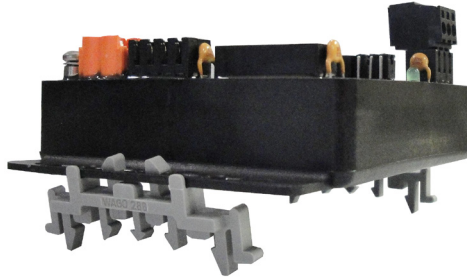

Figure 3: DIN Rail Mounting

Temperature Sensor Installation

Badger Meter offers several styles of 10k Ω Thermistors and 100 Ω Platinum RTDs in both direct immersion and Thermowells. The style selected depends on system requirements and pipe size.

Direct Insert

Generally, direct insert sensors are used for smaller pipe sizes.



Figure 4: Direct Insert

Thermowell

Thermowells are recommended for larger pipes that are more difficult to drain for service.



Figure 5: Thermowell

Hot Tap

For pipes that cannot be drained even for initial installation, we offer a Hot Tap version.

Model THT – available in the 10k Ω Thermistor version only.



Figure 6: Hot Tap

Electrical Installation

All connections to the 340 BN/MB Btu Energy Transmitter are made to screw terminals on removable headers.

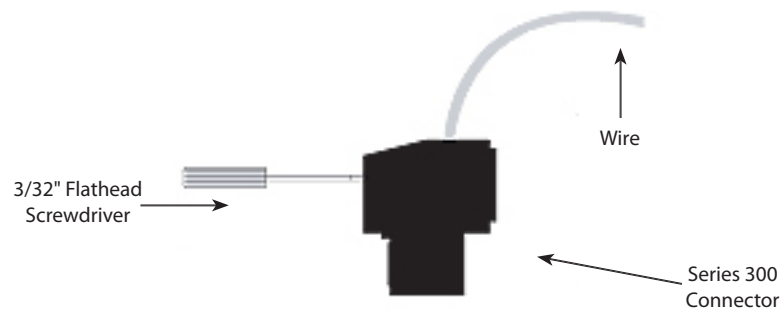

Figure 7: Side View - Typical Series 300 Removable Connector Wiring

Power Supply Wiring

The 340 BN/MB Btu Energy Transmitter requires 12-24 Volts AC or DC to operate. The power connections are made to the ORANGE header. The connections are labeled beside the header. Observe the polarity shown on the label.

If a Badger Meter plug-in type power supply (Series A-1026 or A-503) is used, connect the black/white striped wire to the terminal marked positive (+) and the black wire to the terminal marked negative (-).

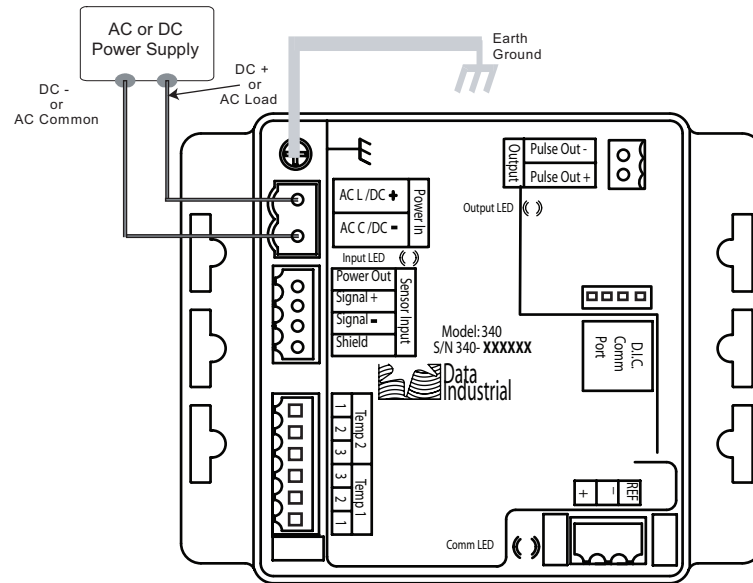

Figure 8: Sample Power Supply Wiring

NOTE: Included with every 340 BN/MB Btu Energy Transmitter is a 340IK kit containing a screw, lock washer and nut to connect the transmitter to earth ground. Connect the earth ground lug of the 340 BN/MB Btu Energy Transmitter to a solid earth ground with as short a wire as possible. This will help prevent electrical interference from affecting the transmitter's normal operation.

Sensor Wiring

All flow sensor types connect to the four terminal headers labeled “Sensor Input.”

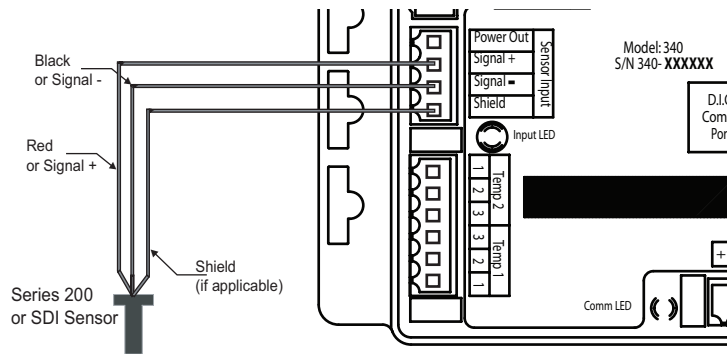

Figure 9: Sample Sensor Wiring Diagram

Series 200

Connect the red wire to sensor signal (+), black wire to sensor signal (-) and the bare wire to shield.

SDI Series

Connect the plus (+) terminal of the sensor to sensor signal (+) on the transmitter and the minus (-) terminal of the sensor to sensor signal (-) on the transmitter. Connect the shield terminal of the sensor to the shield terminal of the transmitter.

Other Flow Sensors

The sensor input power out terminal supplies nominal 12V DC excitation voltage for three-wire sensors. Connect sensor signal (+) and sensor signal (-) wires to transmitter terminals.

The 340 BN/MB Btu Energy Transmitter is very versatile and can accept both pulse and zero crossing sine wave flow sensors. Excitation voltage is also provided for three-wire powered sensors (Example: hall effect, of Badger Meter Series 4000).

See the **Programming** section [page 14](#) for configuration instructions.

Temperature Element Wiring

Appropriate wire types and proper shielding is required for accurate temperature readings.

Since Btu calculations are based on Delta T cable, in order to maintain a balanced system, T1 and T2 wire runs should be kept to approximately the same length, not to exceed 500 feet.

Thermistors

Badger Meter thermistors are not polarity-sensitive, therefore, wire color is unimportant. The thermistor located in the same pipe as the flow sensor, termed temperature sensor T1, should be connected to terminals 2 and 3 on terminal block Temp 1. The thermistor located in the other pipe, termed temperature sensor T2, should be connected to terminals 2 and 3 on terminal block Temp 2. As shown in the thermistor wiring diagram (Figure 10), a jumper must be installed between terminals 1 and 3 for both the T1 and T2 input terminals. These terminals 1 and 3 are used for lead resistance compensation when 100 three-wire RTDs are used and must be jumpered when not used.

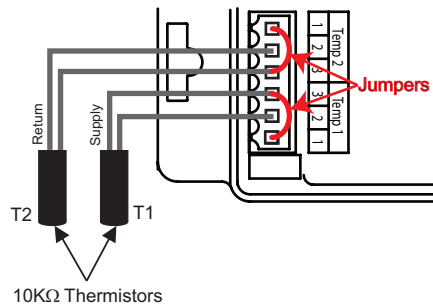

Figure 10: Thermistor Wiring Diagram

Resistance Temperature Detectors (RTDs)

Badger Meter RTDs are three-wire devices. Two of the wires are the same color and interchangeable. One wire is current-carrying and connects to terminal #3, and the other is used for lead compensation and is connected to terminal #1. The single color lead is attached to terminal 2. The RTD located in the same pipe as the flow sensor, temperature sensor T1, should be connected to terminal block Temp 1. The RTD located in the other pipe line, temperature sensor T2, should be connected to terminal block Temp 2.

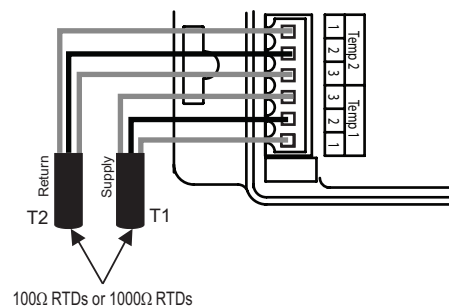

Figure 11: RTD Wiring Diagram

Pulse Output Wiring

The 340 BN/MB Btu Energy Transmitter has solid-state switch output rated for a maximum sinking current of 100 mA at 36V DC. In most cases the pulse out (+) terminal of the 340 BN/MB Btu Energy Transmitter will connect to the input pulse (+) and the pulse out (-) terminal to the input pulse (-) of the receiving device. Although labeled +/-, the pulse output is not actually polarity sensitive and can switch low level AC loads if required.

These terminals are located on a separate two-terminal removable header on the 340 BN/MB Btu Energy Transmitter, labeled "Output."

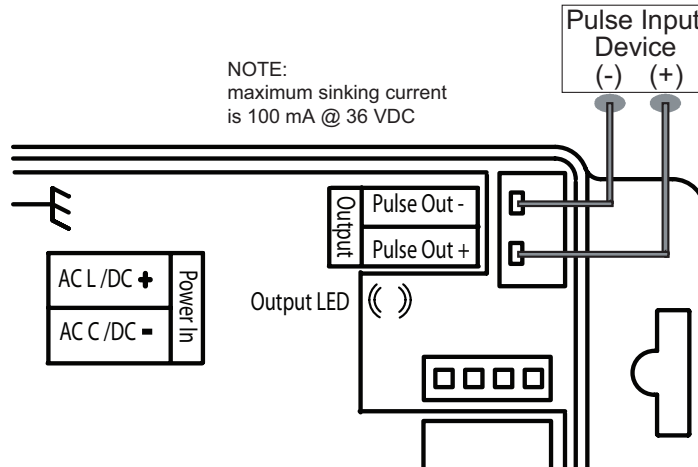

Figure 12: Sample Pulse Output Wiring Diagram

Connecting the RS-485 Buss

As shown in the Sample Pulse Output Wiring Diagram, the position of jumpers on each 340 BN/MB Btu Energy Transmitter and wiring between each transmitter and the RS-485 network are different depending on where the transmitter is installed, that is, its nodal position. For all but the final transmitter in a string, the three jumpers NT, PU and PD should be in the open position, and only the (+) and (-) network terminals should be connected to the RS-485 buss. For the final 340 BN/MB Btu Energy Transmitter in a Modbus network, the three jumpers NT, PU and PD should be in the closed position, and all three network terminals, (+), (-) and REF, should be connected to the Modbus buss.

NOTE: The 340 BN/MB Btu Energy Transmitter default Modbus or BACnet polling address must be changed before it is introduced into an existing network to avoid possible address conflicts. Please refer to programming instructions in the previous section.

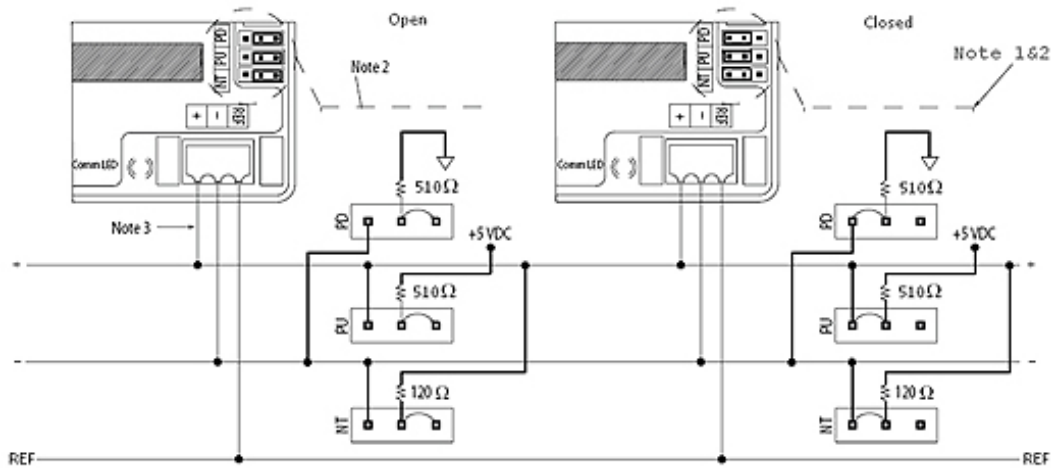

Figure 13: Sample Wiring Diagram to Modbus Network

NOTE 1: Biasing, circuitry and resistors for PU, PD and NT terminals are integral parts of the 340 BN/MB Btu Energy Transmitter.

NOTE 2: For the final 340 BN/MB Btu Energy Transmitter in a given RS-485 network string, NT, PU and PD jumpers should be in the closed position. Otherwise, NT, PU and PD should be in the open position.

NOTE 3: For the final 340 BN/MB Btu Energy Transmitter in an RS-485 string, all three network terminals, (+), (-) and REF, should be connected to the buss. Otherwise, connect only terminals (+) and (-) to the buss.

Connection to the RS-485 network should not be made until the 340 BN/MB Btu Energy Transmitter has been configured per the instructions in "Programming" on [page 14](#).

See **RS-485 Network Configuration** on [page 19](#).

Communications Cable Wiring

Field configuration requires a Data Industrial programming kit (consisting of a custom cable and software) and a PC running Windows 9x, ME, NT, 2000 or Windows 7. In order to connect, the 340 BN/MB Btu Energy Transmitter must be powered, and the Data Industrial Series A301 cable must be connected to the 340 BN/MB Btu Energy Transmitter COM port connector and an available 9-pin COM port on a computer. USB to COM Port adapters can be used if the DB9 COM port is not available.

NOTE: The Data Industrial A301 Cable will work with all Series 300 products. However the older version of the cable (A300) does not have sufficient bandwidth to work with the 340 BN/MB Btu Energy Transmitters.

Badger Meter provides free programming software updates via the Internet for all Series 300 products. Go to www.badgermeter.com. Software updates can be found in the Industrial/Impeller/Transmitter section.

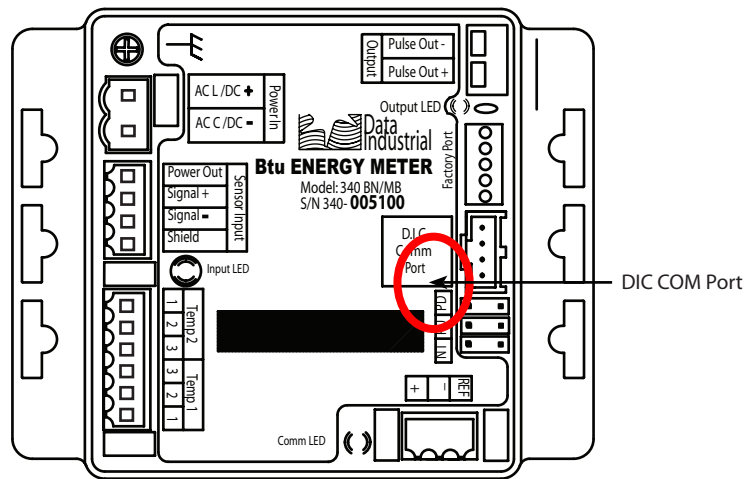

Figure 14: Location of the DIC COM Port

PROGRAMMING

Connecting Via DIC COM Port

Programming the 340 BN/MB Btu Energy Transmitter is accomplished by installing Badger Meter programming software on a computer and entering data on templates of the Windows based program.

1. Load the interface software into the computer.
2. Power the 340 BN/MB Btu Energy Transmitter with 12-24V AC/DC.
3. Connect the computer to the transmitter with the Data Industrial Series A-301 communications cable to the socket labeled "D.I.C. COM port", taking care to properly align the tab on the plug and socket to maintain polarity. Connect the DB9 connector of the Data Industrial Series A301 communications cable to a PC COM port that has the 340 software installed. If a DB9 COM port is not available, a USB to COM Port Adapter may be purchased locally.
4. Open the program and from the Device tab and select **340** as shown in the dialog box below.

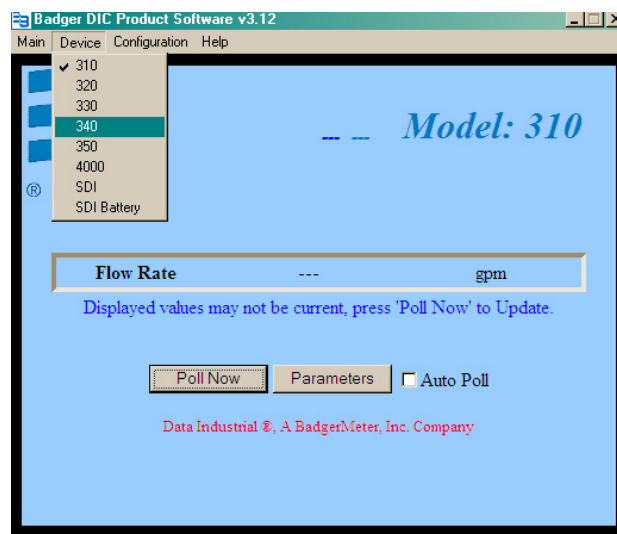

Figure 15: Select 340

5. After the 340 device has been selected, select the Type, **340BN/MB**.

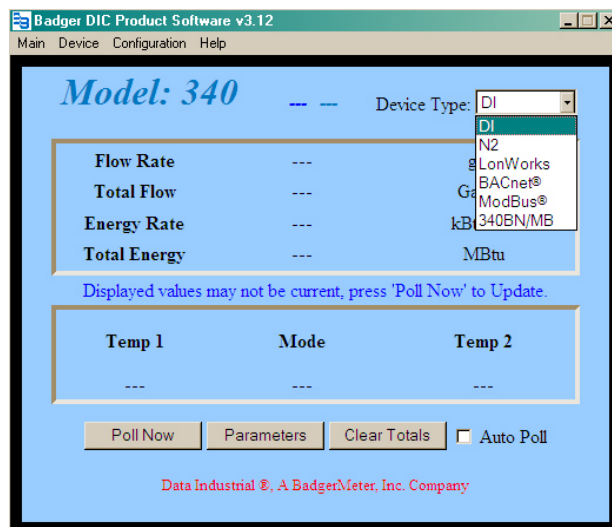

Figure 16: Device Type

- Once 340BN/MB has been selected, the appropriate COM port can be selected from the Configuration tab.

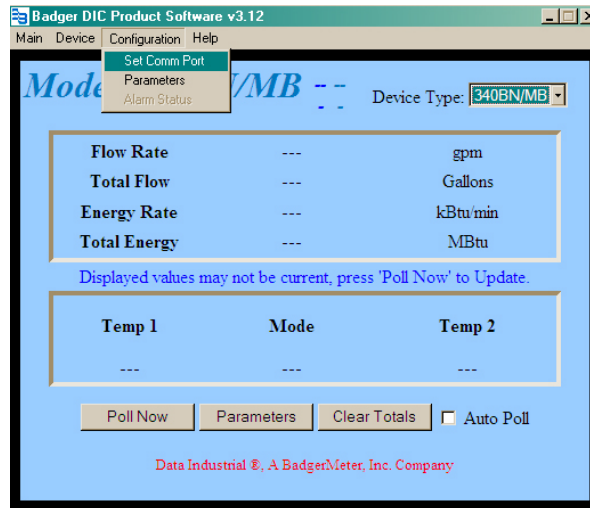

Figure 17: Select Set COM Port

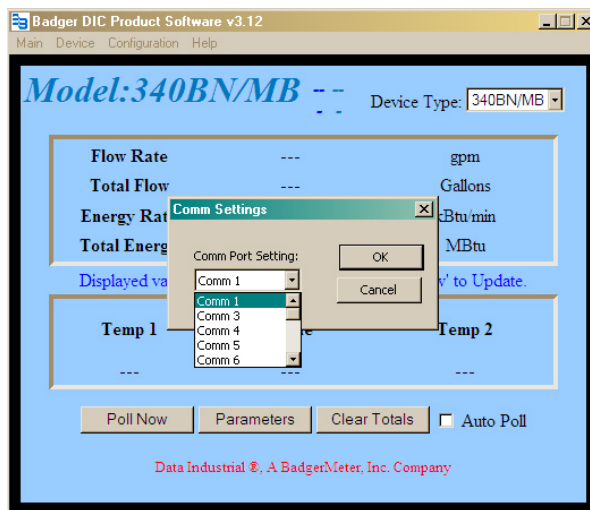

Figure 18: Select the COM Port

- If the COM and Device type have been properly selected, the "---" will be replaced with values.

NOTE: If this does not occur, communication has not been established and you cannot continue to the next step. If it does not connect automatically try clicking on Poll Now.

NOTE: If communication still does not occur and you are using a DB9 to COM 1 or COM2, try using a USB to COM adapter. This will usually create a new COM port that was not previously listed. Windows Device Manager can be helpful in determining the actual COM ports that are available.

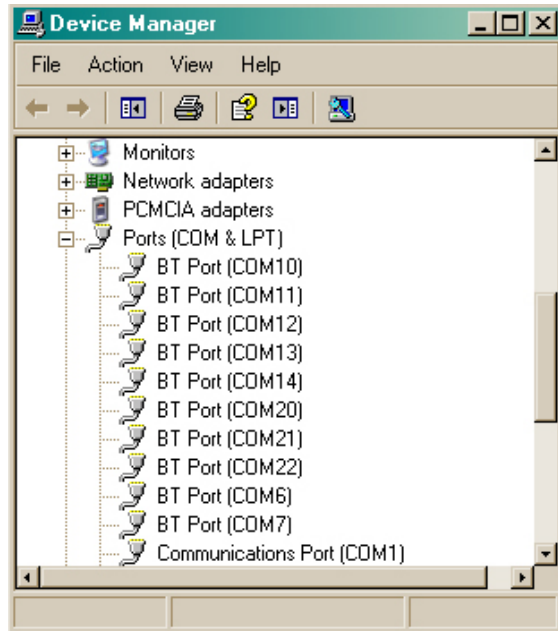

Figure 19: Device Manager

Select this new port created by the adapter and the screen should change as shown (Figure 20). Notice that the "----" are replaced with values. This confirms normal communications.

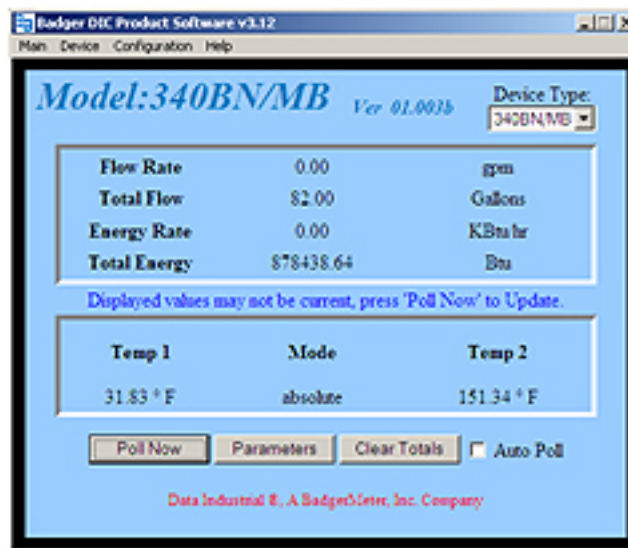

Figure 20: Screen Change

8. When communication has been confirmed, click on the **Parameters** button. The Parameters screen is displayed.

Figure 21: Parameters Screen

9. From this screen set up the following:
1. Flow Sensor Type, Scaling and Units
 2. Temperature Sensor Type, Units, Mode and Zeroing
 3. Energy Calculation Units of Measure
 4. Filter Coefficients (Flow and Energy averaging for reading stability)
 5. Scaled Pulse Output Resolution and Pulse Width
 6. RS-485 Network Configuration (BACnet or Modbus)
10. Be sure to press **Send** before leaving this page to save any wanted changes.

Refresh rereads the unit and refreshes the screen. **Defaults** will restore all factory settings. **Exit** returns to the Main Screen.

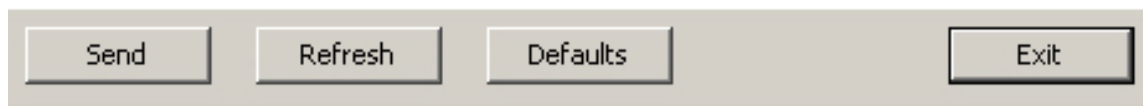

Figure 22: Parameter Screen Buttons

Flow Sensor Section

Data Industrial 340 BN/MB Parameter

Flow Sensor

Pulse Sine

K = 39.047241

Offset = 0.000000

Rate Units = gpm

Total Units = Gallons

Figure 23: Pulse or Sine

For most Data Industrial sensors, the sensor type is “Pulse”, and the “K” and “Offset” values can be found in the respective Flow Sensor Manual.

“Sine” is used for zero-crossing flow sensors (some turbine meters, etc.)

Several flow rate and flow total units of measure can be selected from the pull-down menu.

Temperature Sensor Section

Temperature Sensor

T1 = 31.8289 °F T1 Correction (°C) = 0.0000

T2 = 151.3298 °F T2 Correction (°C) = 0.0000

Units °F °C Zero Temp. Diff.

Calc Mode T1 > T2 Absolute T1 < T2

Sensor Type 10K Therm 100 RTD 1K RTD

Figure 24: Sensor Attributes

First choose the **Sensor Type** (10K Ω Thermistor, 100 Ω RTD, or 1K RTD).

The **Calc(ulation) Mode** has three selections. Initially, it is best to choose “Absolute.” In this mode the Energy Rate and Total will be calculated as a positive value regardless of the direction of energy flow.

In the **T1>T2 Mode**, energy will only be calculated if the T1 sensor is warmer than the T2 sensor. If T1 is cooler than T2, the energy rate will remain at 0.0 and the energy total will not increase.

In the **T1<T2 Mode**, energy will only be calculated if the T1 sensor is cooler than the T2 sensor.

The **T1=** and **T2=** are simply for reference to indicate the current temperature readings.

This is useful in using the zeroing feature explained on page 19.

The **Zero Temp Diff** is a very powerful feature in this product which allows any inaccuracies of drift in the temperature sensors, or the 340 BN/MB Btu Energy Transmitter temperature measurements, to be cancelled out.

This correction can be either manually typed in or if the temperature sensors are known to be at exactly the same temperature, the **Zero Temp Diff** button can be used to automatically zero the difference between the two readings. To correct for any erroneous entries, simply manually type 0.0 in both fields.

This feature must be used with caution. If used incorrectly, the temperature readings will be incorrect and the energy rates and totals will also be in error.

Energy Calculation

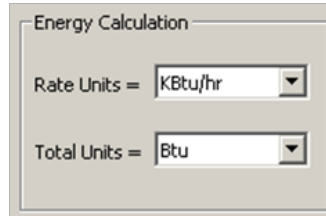

Figure 25: Rate and Total Units

Select the units of measure for energy rate and total from the pull-down menus.

Filter Coefficients

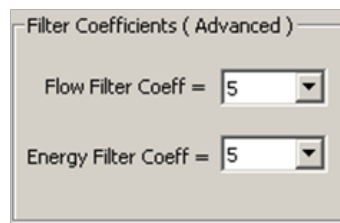

Figure 26: Filter Coefficients

For most applications leave the default setting of 5. If the flow rate or energy rates are unstable for some reason (from a disturbed flow profile, for example) this value can be increased as needed.

Pulse Output

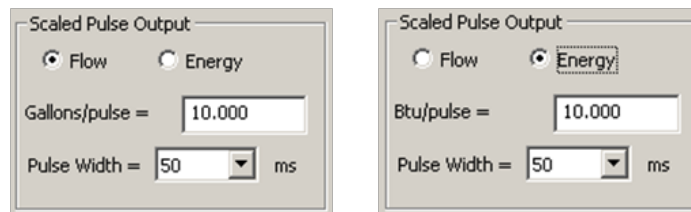

Figure 27: Flow or Energy

The pulse output can represent either **flow** or **energy**. Units will be the same as selected in the previous sections.

Pulse width and pulse resolution will be selected based on the requirements of the receiving device and system requirements.

RS-485 Network Configurations

The RS-485 Section can be configured in three ways:

- Pulse Out Only – RS-485-OFF
- Modbus
- BACnet

The following sections explain each in detail.

RS-485 Network Configuration – Pulse Out Only

The screenshot shows a configuration window titled "Network" with a tab labeled "RS-485 Test". Under "Network Type", the "Pulse Out Only" radio button is selected. The "Address" field contains the value "15". The "Bit Rate" dropdown menu is set to "19200". The "Modbus Mode" dropdown menu is set to "RTU". On the right side, the "BACnet Device Name" field contains "340 BN/MB Energy Meter", the "BACnet Device ID" field contains "52001", and the "BACnet Max Master" field contains "127".

Figure 28: Pulse Out Only Option

If the Modbus or BACnet communications are not going to be used, the **Pulse Out Only** setting can be selected. This will disable the RS-485 Network.

RS-485 Network Configuration – Modbus

The screenshot shows a configuration window titled "Network" with a tab labeled "RS-485 Test". Under "Network Type", the "Modbus" radio button is selected. The "Address" field contains the value "15". The "Bit Rate" dropdown menu is set to "9600". The "Modbus Mode" dropdown menu is set to "RTU". On the right side, the "BACnet Device Name" field contains "340 BN/MB Energy Meter", the "BACnet Device ID" field contains "52001", and the "BACnet Max Master" field contains "127".

Figure 29: Modbus Option

Select **Modbus**, to access the Modbus pull down menus.

Select the **Address**, **Bit Rate** (Baud Rate) and **Mode** (RTU or ASCII).

The 340 BN/MB Btu Energy Transmitter uses IEEE 754 Float - Data Located in "Holding Registers."

The 340BN/MB Data Format is "Float 32" where the Data is stored across two "Holding Registers".

In the case of Temperature 1, the Upper Byte is stored in Register 40002, and the Lower Byte is stored in Register 40001, sometimes referred to as an ABCD to CDAB format. This is done to permit backwards compatibility with older 16-bit systems.

For example, a temperature of 53.36° F when converted to IEEE 754 is "425570A4." So in the case of the 340BN/MB, Register # 40001 = 70A4 Hex and Register # 40002 = 4255 Hex. See the table on the next page for additional information.

Modbus Register Map

Model 340BN/MB Register Map			
Register Name	Address	Data Type	Read/Write
Temperature 1	40001 + 40002	IEEE 754 Float	Read Only
Temperature 2	40003 + 40004	IEEE 754 Float	Read Only
Flow Input (Hz)	40005 + 40006	IEEE 754 Float	Read Only
Total Flow	40007 + 40008	IEEE 754 Float	Read Only
Total Energy	40009 + 40010	IEEE 754 Float	Read Only
Flow Rate	40011 + 40012	IEEE 754 Float	Read Only
Energy Rate	40013 + 40014	IEEE 754 Float	Read Only
K Factor	40015 + 40016	IEEE 754 Float	Read Only
Offset	40017 + 40018	IEEE 754 Float	Read Only
Temp Calc Mode	40019 + 40020	IEEE 754 Float	Read Only
Flow Filter Coef	40021 + 40022	IEEE 754 Float	Read Only
Temp Filter Coef	40023 + 40024	IEEE 754 Float	Read Only
Specific Heat	40025 + 40026	IEEE 754 Float	Read Only
Fluid Density	40027 + 40028	IEEE 754 Float	Read Only
T1 A Coefficient	40029 + 40030	IEEE 754 Float	Read Only
T1 B Coefficient	40031 + 40032	IEEE 754 Float	Read Only
T1 C Coefficient	40033 + 40034	IEEE 754 Float	Read Only
Temp 1 Offset	40035 + 40036	IEEE 754 Float	Read Only
T1 A Coefficient	40037 + 40038	IEEE 754 Float	Read Only
T1 B Coefficient	40039+ 40040	IEEE 754 Float	Read Only
T1 C Coefficient	40041 + 40042	IEEE 754 Float	Read Only
Temp 1 Offset	40043 + 40044	IEEE 754 Float	Read Only

RS-485 Network Configuration – BACnet

The screenshot shows a 'Network' configuration window. At the top, 'Network Type' has three radio buttons: 'BACnet' (selected), 'Modbus', and 'Pulse Out Only'. To the right is a 'RS-485 Test' button. Below are several input fields: 'Address = 15', 'BACnet Device Name = 340 BN/MB Energy Meter', 'Bit Rate = 19200' (with a dropdown arrow), 'BACnet Device ID = 52001', 'Modbus Mode = RTU' (with a dropdown arrow), and 'BACnet Max Master = 127'.

Figure 30: BACnet Option

Select **BACnet** to access the BACnet pull down menus.

Select the **Bit Rate** (BAUD rate) to match other devices on the network.

BACnet Device Name can be set to help identify this device and location.

BACnet Device ID (Incidence #) is a unique number that identifies this device on the network. Typically, the first part of the number is the same as the network #, and the last two characters are the same as the **Address**.

NOTE: This is not a requirement, but can help in system planning.

BACnet Object Map

Description	ID	Name	Out of Service	Units
Analog Input	AN1	TempIn	FALSE	° C, ° F
Analog Input	AN2	TempOut	FALSE	° C, ° F
Analog Input	AN3	FreqIn	FALSE	Hz
Analog Input	AN4	VolFlow	FALSE	gpm, gph, lpm, lph, ft ³ /s, ft ³ /m, ft ³ /h, m ³ /s, m ³ /min, m ³ /h
Analog Input	AN5	EnrgyFlow	FALSE	kBtu/min, kBtu/h, kW, MW, HP, Tons
Analog Value	AV1	TotalVol	FALSE	gallons, liters, ft ³ , m ³
Analog Value	AV2	TotEnergy	FALSE	Btu, kBtu, MBtu, kWh, MWh, kJ, MJ
Analog Value	AV3	Kfactor	FALSE	dimensionless
Analog Value	AV4	Offset	FALSE	dimensionless
Analog Value	AV5	TempMode	FALSE	dimensionless
Analog Value	AV6	FFilterCoef	FALSE	dimensionless
Analog Value	AV7	TFiltCoef	FALSE	dimensionless
Analog Value	AV8	SpHtCapac	FALSE	Btu/lb-F
Analog Value	AV9	Density	FALSE	lb/gallon
Analog Value	AV10	InTACoef	FALSE	dimensionless
Analog Value	AV11	InTBCoef	FALSE	dimensionless
Analog Value	AV12	InTCCoef	FALSE	dimensionless
Analog Value	AV13	InTOffset	FALSE	° C, ° F
Analog Value	AV14	OutTACoef	FALSE	dimensionless
Analog Value	AV15	OutTBCoef	FALSE	dimensionless
Analog Value	AV16	OutTCCoef	FALSE	dimensionless
Analog Value	AV17	OutTOffset	FALSE	° C, ° F

BACnet Protocol Implementation Conformance Statement

Products				
Product	Model Number	Protocol Revision	Software Version	Firmware Version
340 BN/MB	B340BN	135-2001		Rev 1.00
Vendor Information				
Badger Meter, Inc 6116 E 15th Street Tulsa, OK 74112 www.badgermeter.com				
Product Description				
The 340 BN/MB Btu Energy Transmitter is a low cost, flow and temperature sensor interface used in submetering applications. An additional communication design feature provides connectivity for BACnet® MS/TP.				
BACnet Standardized Device Profile				
Product	Device Profile			Tested
340 BN/MB	BACnet Smart Sensor (B-SS)			
Supported BIBBs				
Product	Supported BIBBs	BIBB Name		Tested
340 BN/MB	DS-RP-B	ReadProperty-B		
	DS-WP-B	WriteProperty-B		
Standard Object Types Supported				
Product	Object Type	Creatable	Deletable	Tested
340 BN/MB	Analog Input	No	No	
340 BN/MB	Analog Value	No	No	
340 BN/MB	Device	No	No	
Data Link Layer Options				
Product	Data Link	Options		Tested
340 BN/MB	MS/TP Slave	Baud rates 9600, 19200, 38400, 75800		
Segmentation Capability				
Product	Segmentation Type	Supported	Window Size <small>(M8/TP product limited to 1)</small>	Tested
340 BN/MB	Able to fragment segmented messages	No		N/A
Device Address Binding				
Product	Static Binding Supported	Tested		
340 BN/MB	No	N/A		
Character Sets				
Product	Character Sets Supported	Tested		
340 BN/MB	ANSI X3.4			

RS-485 Network Test

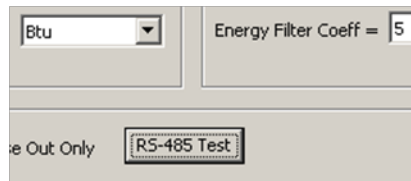

Figure 31: RS-485 Test

The Configuration Software has an RS-485 test program.

Although it uses Modbus settings, it is testing RS-485 communication.

The test requires connection to a COM port using the Data Industrial A302-20 RS 485 to RS-232 convertor cable. This cable can also be helpful with other diagnostics programs and devices that use an RS-232 port to communicate.

When testing the RS-485 network, it is sometimes helpful to connect to some other location instead of directly to the 340 BN/MB Btu Energy Transmitter. When testing in this way the RS-485 end connector can be removed, and the wires can be connected directly to the RS-485 pairs.

The following table may be helpful to make connections.

302 Cable w/RS-485 End	340 BN/MB	340 N2	Series 3000
Red	RS-485 +	N2 +	RS-485B
White	RS-485 -	N2 -	RS-485A
Black	REF	REF	RS-485 Gnd

When the **RS-485 Test** button is selected the following screens appear:

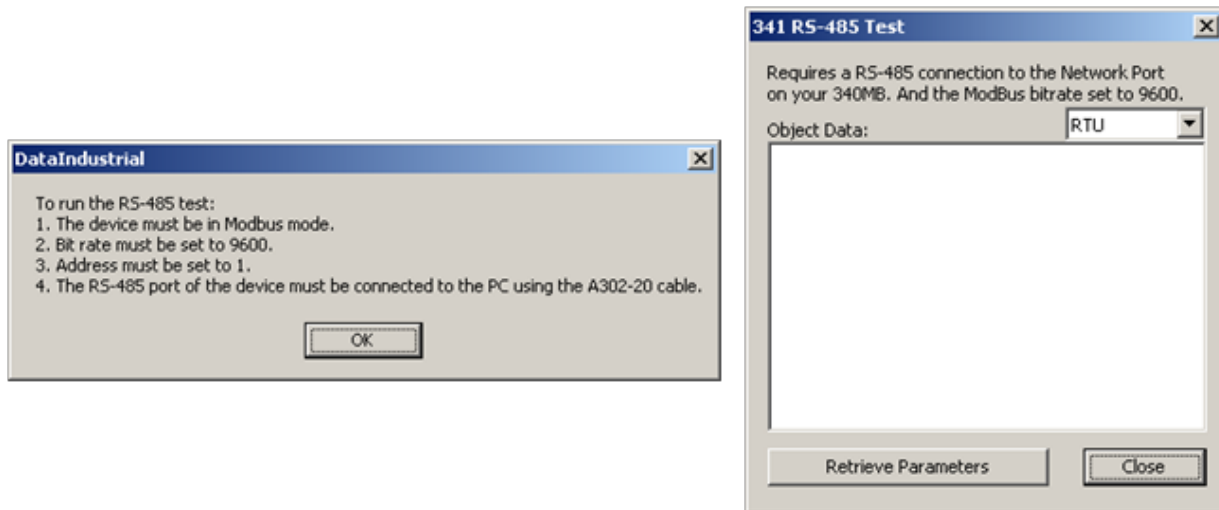

Figure 32: Test Screens

Factory Default Settings

The table below is a list of factory default setting for all 340BN/MB variables. These settings can be changed by accessing the parameters to best fit your application, and if desired, recorded in the table for future reference.

Description	Default Value	Customer Value
Flow Sensor Type	Pulse	
"K" Offset	1	
"Offset" Value	0	
Flow Rate	gpm	
Flow Total	gallons	
Temperature	° F	
Energy Calculation	absolute	
Temperature Sensor Type	thermistor	
Energy Rate	kBtu/hr	
Energy Total	Btu	
Flow Filter Coefficient	5	
Energy Filter Coefficient	1	
Energy Filter Coefficient	1	
MS/TP Address	1	
MS/TP Baud Rate	9600	
BACnet Device #	—	
BACnet Max Master	127	

SPECIFICATIONS

POWER

Power supply options:

12...35V DC

12...24V AC

Current draw:

115 mA max. @ 12V DC

FLOW SENSOR INPUT

Pulse type sensors

Signal amplitude:

2.5V DC threshold

Signal limits:

Vin < 12V (DC or AC peak)

Frequency:

4...10000 Hz

Pull-up:

2k Ω to 15V DC

Sine wave sensors

Signal amplitude:

30 mV p-p threshold

Signal limits:

Vin < 12V (DC or AC peak)

Frequency:

4...10000 Hz

Excitation voltage 3-wire sensors

7.0V DC to 11.4 V DC 500 Ω source impedance

TEMPERATURE SENSOR INPUT

2 required:

10k Ω thermistor, 2 wire, type II, 10k Ω , @ 25°C

100 Ω RTD, Platinum three wire,

1000 Ω RTD, Platinum, two or three wire

RTDs follow IEC 751 DIN Curve

PULSE OUTPUT

Pulse width:

Programmable 10 ms to 5 sec. in 50 ms steps

Pulse frequency:

Max of 10 Hz at 50 ms pulse width programmable to scaling

requirements of connected device (Flow or Energy)

Opto-isolated solid state switch

Operating voltage range:

0 to \pm 45V (DC or AC peak)

Closed (on) state:

Load Current - 700 mA max.

over operating temperature range

Open (off) state - leakage @ 70°C

<1 μ A @ 45V (DC or AC peak)

OPERATING TEMPERATURE

0...70° C

32...158° F

Storage Temperature

-40...85° C

-40...185° F

WEIGHT

4.8 oz with connector headers installed

SENSOR CALIBRATION

Badger Meter –

Use K and Offset provided in sensor owner's manual

Other sensors –

Check with factory

UNITS OF MEASURE

Flow measurement

Rate:

gpm, gph, l/sec, l/min, l/hr, ft³/sec, ft³/min,

ft³/hr, m³/sec, m³/min, m³/hr

Total:

gallons, liters, cubic feet, cubic meters

Energy measurement

Rate:

kBtu/min, kBtu/hr, kW, MW, hp, tons

Total:

Btu, kBtu, MBtu, kWh, MWh, kJ, MJ

Temperature Units:

Fahrenheit, Centigrade

PROGRAMMING

Requires PC or laptop running Windows® XP, Vista or Windows 7

Data Industrial 340 BN/MB Programming Kit A301-20 containing software and programming cable

INTENTIONAL BLANK PAGE

Data Industrial is a registered trademarks of Badger Meter, Inc. Other trademarks appearing in this document are the property of their respective entities.
Due to continuous research, product improvements and enhancements, Badger Meter reserves the right to change product or system specifications without notice, except to the extent an outstanding contractual obligation exists. © 2012 Badger Meter, Inc. All rights reserved.

www.badgermeter.com

The Americas | Badger Meter | 4545 West Brown Deer Rd | PO Box 245036 | Milwaukee, WI 53224-9536 | 800-876-3837 | 414-355-0400
México | Badger Meter de las Americas, S.A. de C.V. | Pedro Luis Ogazón N°32 | Esq. Angelina N°24 | Colonia Guadalupe Inn | CP 01050 | México, DF | México | +52-55-5662-0882
Europe, Middle East and Africa | Badger Meter Europa GmbH | Nurtinger Str 76 | 72639 Neuffen | Germany | +49-7025-9208-0
Czech Republic | Badger Meter Czech Republic s.r.o. | Mařikova 2082/26 | 621 00 Brno, Czech Republic | +420-5-41420411
Slovakia | Badger Meter Slovakia s.r.o. | Racianska 109/B | 831 02 Bratislava, Slovakia | +421-2-44 63 83 01
Asia Pacific | Badger Meter | 80 Marine Parade Rd | 21-04 Parkway Parade | Singapore 449269 | +65-63464836
China | Badger Meter | Rm 501, N° 11 Longyue Apartment | N° 180 Longjin Rd, Jiuting Songjiang District | Shanghai, China | 201615 | +86-21-5763 5412