

Vinotemp®

A PROUD HERITAGE OF EXPERIENCE & QUALITY



WINE CELLAR

VINOCELLIER MODELS (SMALL AND LARGE MODELS)

O w n e r ' s M a n u a l

Vinotemp®

W W W . V I N O T E M P . C O M

YOUR WINE CELLAR

This unit can be used for Storage and/or Service. The unit has a glass door or a solid door.

SERVING WINES

Storing wines at the proper temperature is important. To preserve them as long as possible wine should be stored at approximately 55° Fahrenheit. However, the chart below suggests the optimal drinking temperature for the different styles of wine.

°C	°F	Wine Style
19	66	Armagnac, Brandy, Cognac
18	64.5	Full Bodied Red wines, Shiraz
17	62	Tawny Port
15	59	Medium Bodied Red Wines
14	57	Amontillado Sherry
13	55.5	Light Bodied Red Wines
12	53.5	Full Bodied White Wines
11	52	Medium Bodied White Wines
10	50	Rosé, Light Bodied White Wines
9	48	Vintage Sparkling
8	46.4	Fino Sherry
7	44.5	Non Vintage Sparkling

GENERAL OPERATING INSTRUCTIONS

Remove all packaging and labels from your wine cellar. Be sure that all parts have been included before discarding any packaging materials. You may want to keep the box and packing materials for use at a later date.

Upon receipt of unit and inspection, the supply cord must be replaced if it is damaged. Contact our customer service at 1-800-777-8466.

- Let the unit rest, UNPLUGGED for 48 hours once you have it placed in your home.
- Please fully read the instruction manual.

**Please read and follow all safety rules
and operating instructions before using.**

TABLE OF CONTENTS

PARTS AND SPECIFICATIONS	4
IMPORTANT SAFETY INSTRUCTIONS	6
CORD INSTRUCTIONS	6
INSTALLATION INSTRUCTIONS	7
LAYOUT AND LOADING RECOMMENDATIONS	8
SECURITY LOCK	9
ELECTRONIC CONTROLLER/DISPLAY	9
TEMPERATURE CONTROL	10
TEMPERATURE ALARM	10
CLEANING AND CARE	11
EVERYDAY CABINET CARE TIPS	11
TROUBLESHOOTING	12
TERMS OF SALE AND WARRANTY	13



PARTS AND SPECIFICATIONS

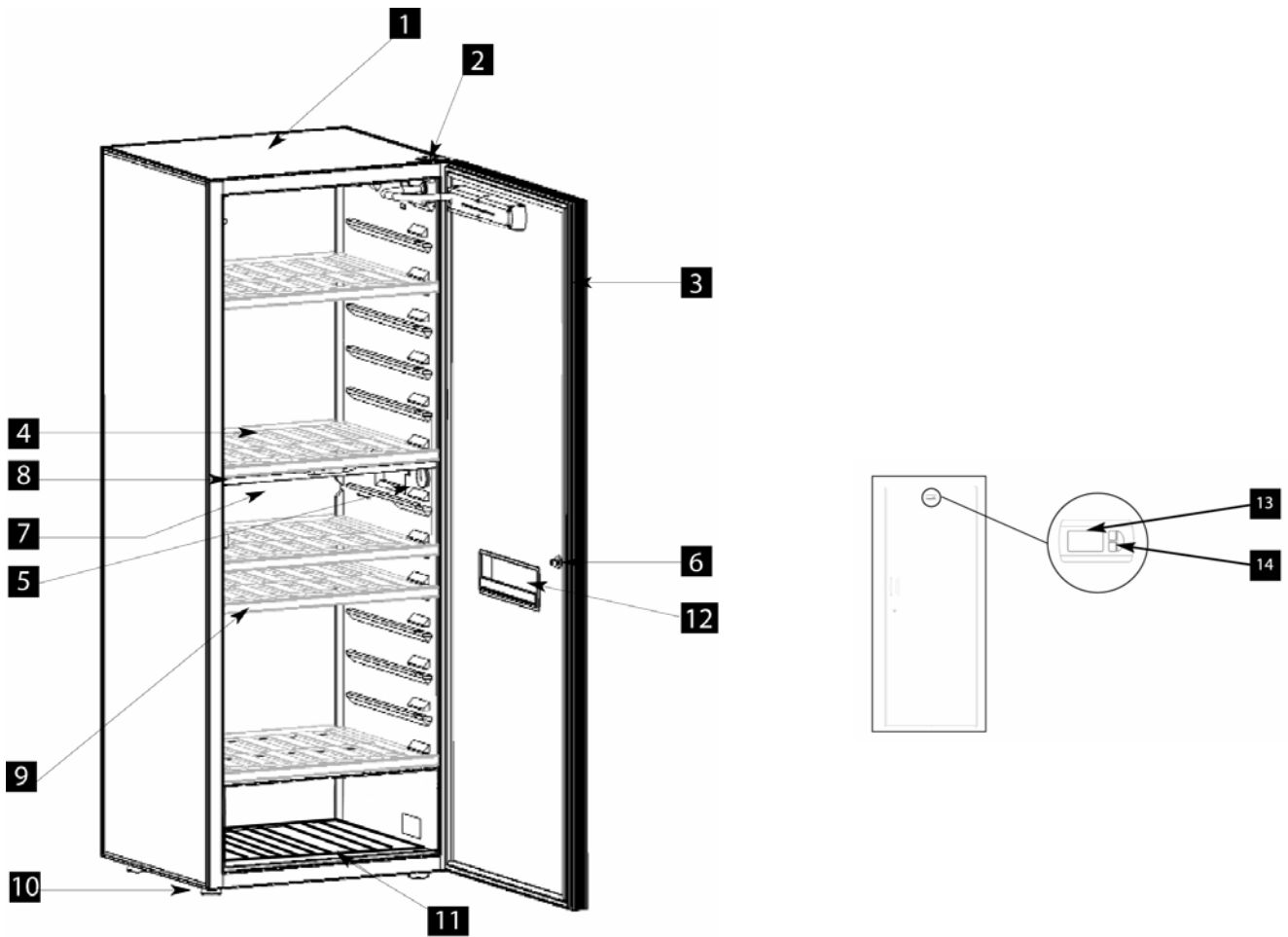

1. Cabinet Body
2. Hinge
3. Door
4. Universal shelf (storage and/or presentation configuration)
5. Hygrometry
6. Lock
7. Thermodynamic pump opening
8. Rigidity Bar (not present on all models)
9. Universal shelf (sliding configuration)
10. Adjustable foot (4)
11. Wire shelf
12. Storage tray
13. Temperature display (position may vary for glass door models)
14. Temperature adjustments

LARGE MODEL

Item(s)	VT-CAVE SD and VT-CAVE G
Bottle Capacity	Approx. 267
Dimension (HxWxD)	71.25"x26.8"x26.8"
Power Consumption	1.2kw.h/24h
Cooling System	R134a
Ambient Temp	0 ~ 95°F
Temperature Range	50 ~ 57°F
Rated Voltage / Rated Frequency	115V / 60Hz
Input Power	140W

SMALL MODEL

Item(s)	VT-CAVE 150 SD
Bottle Capacity	Approx. 159
Dimension (HxWxD)	43"x26.8"x26.8"
Power Consumption	0.5kw.h/24h
Cooling System	R134a
Ambient Temp	0 ~ 95°F
Temperature Range	50 ~ 57°F
Rated Voltage / Rated Frequency	115V / 60Hz
Input Power	140W

IMPORTANT SAFETY INSTRUCTIONS

When using an electrical appliance, basic precautions should be followed to reduce the risk of fire, electric shock, and personal injury.

1. Use this appliance only as described in this manual. Other uses are not recommended, as it may cause fire, electric shock or personal injury.
2. This product is intended for indoor, household use.
3. To protect against electric shock, do not immerse unit, plug or cord in water or other liquids.
4. Keep away from children.
5. Unplug unit from the outlet when not in use, when moving from one location to another or before cleaning.
6. To disconnect the appliance, grip the plug and pull it from the wall outlet. Never pull by the cord.
7. Do not operate the appliance in the presence of explosive and/or flammable fumes.
8. Do not place the appliance or any of its parts near an open flame, cooking or other heating appliance.
9. Do not operate the appliance with a damaged cord or plug. If the product malfunctions, or if it is dropped or damaged in any manner, do not use.
10. The use of attachments is not recommended and may be hazardous.
11. Place the unit on a dry, level surface.
12. Unit is not designed for use in a garage or basement.
13. Do not operate if the housing is removed or damaged.
14. A loose fit between the AC outlet (receptacle) and plug may cause overheating and a distortion of the plug. Contact a qualified electrician to replace loose or worn outlet.
15. This appliance is designed to be free standing (not built-in).
16. The wine cellar is intended for use in a controlled ambient location so that the ambient temperature does not exceed 90°F (32°C).
17. Locate the unit away from direct sunlight and sources of heat (stove, heater, dishwasher, refrigerator, radiator, etc.).

IMPORTANT: Any work carried out on the cooling unit must be done by a professional refrigerator technician, who must check the circuit for leaks before switching the appliance back on. Likewise, any work carried out on the electrical circuit must be done by a qualified electrician.

WARNING: To reduce the risk of fire, electric shock or personal injury, unplug or disconnect the appliance from the power supply before servicing.

CORD INSTRUCTIONS

For your protection, this unit is equipped with a 3-conductor cord set that has a molded 3-prong grounding-type plug, and should be used in combination with a properly connected grounding-type outlet as shown in figure A. Not for use with an extension cord.

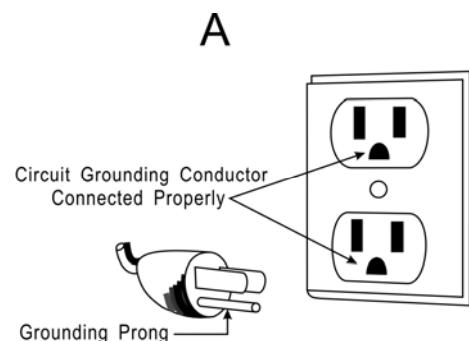

INSTALLATION INSTRUCTIONS

1. Carefully remove all of the packaging around your wine cabinet.
2. Place your wine cellar on a solid, flat surface that is strong enough to support the unit when fully loaded.
3. Allow a minimum 4-inch space between the wall and the back of the cabinet.
4. Open the door and make sure all components are intact.
5. Release the cord and plug the power cord into a standard electrical outlet.

Aligning Your Wine Cellar

In order for you to level off your cabinet as easily as possible, it is equipped with 4 adjustable feet. However, we recommend that you tighten the back feet to the maximum and use the front feet to create a level.

Important Placement Notes

- ◆ Select a well-ventilated area for best performance.
- ◆ This wine cellar is designed to be free standing and for indoor use only.
- ◆ Do not place the unit in a moist location or near a heat source, including other major appliances or direct sunlight.
- ◆ Do not plug unit into the same outlet as a refrigerator or microwave.
- ◆ Do not place heavy objects on top of the unit.

Important: WAIT 48 HOURS BEFORE PLUGGING IN THE CABINET

Should you need to move your cabinet, never tilt it more than 45° and always tilt sideways, on the side that the electrical cable comes out (right hand side when looking at the cabinet.)

LAYOUT AND LOADING RECOMMENDATIONS

Each shelf can be used as a storage, presentation or sliding shelf. Each of your wine cabinet's shelves has 13 recesses for bottles, enabling you to place your bottles in total safety. Also, all shelves have a label slot designed to receive the pre-cut cards delivered with your cabinet, helping you to identify the position of your favorite wines at a glance.

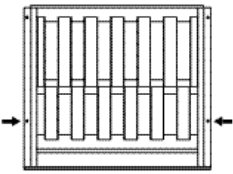
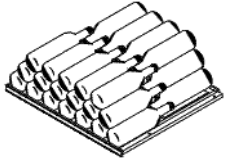

Storage shelf configuration:

- Install the shelf in the selected location.
- Place a wooden locking pin in each of the two holes located on the right and left of the upper face approximately 15 cm in front of the shelf: these pins butt up against the heat shaped wall and avoid all accidental shelf movement (See diagram).
- Start by placing the bottles in the rear recesses with the base of the bottle towards the back.
- Continue by placing the bottles in the front recesses, facing them in the opposite direction.
- Continue stacking the bottles in this way making sure that no bottle touches the rear wall.

A storage shelf can hold a maximum of 6 layers, 13 bottles on each layer, representing 78 "Standard" Bordeaux bottles (100kg).

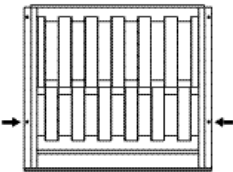
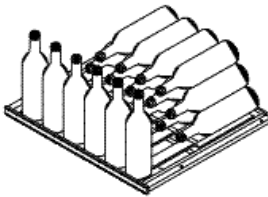

Presentation shelf configuration:

- Install the shelf in the selected location.
- Place a wooden locking pin in each of the two holes located on the right and left of the upper face approximately 15 cm in front of the shelf: these pins butt up against the heat shaped wall and avoid all accidental shelf movement (See diagram).
- Start by placing the bottles in the rear recesses with the base of the bottles towards the back (6 "Standard" Bordeaux bottles).
- Continue stacking the bottles on the rear recesses (7+6+7+6 = 26 "Standard" Bordeaux bottles) making sure that no bottle touches the rear wall.
- To present the bottles, place them in an upright position on the front of the shelf (Maximum capacity: 6 "Traditional" Bordeaux bottles).

In presentation configuration, a shelf can hold a maximum of 38 "Traditional" Bordeaux bottles.

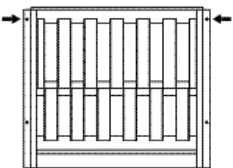
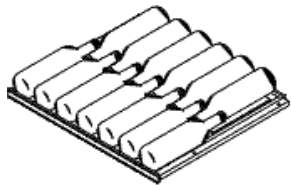

Sliding shelf configuration:

- Install the shelf in the selected location.
- Place a wooden locking pin in each of the two holes located on the right and left of the upper face approximately 4 cm to the rear of the shelf: when the shelf is slid forwards, these pins stop it from sliding completely out of the cabinet (See diagram).
- Start by placing the bottles in the rear recesses with the base of the bottles towards the back.
- Continue by placing the bottles in the front recesses facing them in the opposite direction.

A sliding shelf can only hold one layer of bottles (maximum of 13 "Traditional" Bordeaux bottles). In order to enjoy optimum accessibility when setting up the cabinet in a mixed layout, we recommend that shelves to be used as sliding shelves are located in the middle section of the cabinet.

SECURITY LOCK

As a security measure, the lock on your wine cellar works on a double movement system. The key should be pushed inward and turned at the same time to operate.

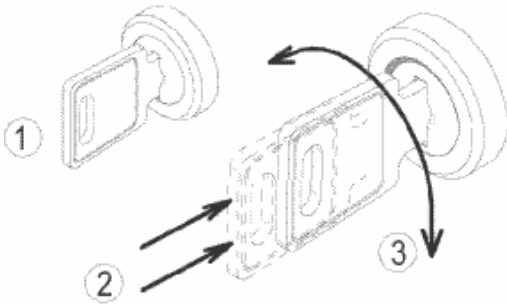

ELECTRONIC CONTROLLER/DISPLAY



For Glass Door Cabinets Only:

If you push upwards on the electronic controller, it will be hidden in the ceiling of the cabinet and display will not be visible.

If you push upwards again, the controller will come back into its original position.



For transport purposes, cabinets may ship with the electronic controller in hidden position.

TEMPERATURE CONTROL





During operation, the value displayed on the control panel when the keys are not being pressed, is always the temperature inside the cabinet.

Temperature Adjustment Order/Process

1. If you want to increase both the upper and lower settings, it is essential that you adjust the upper setting first (SET2), then the lower setting (SET1).
2. When you want to lower both settings (lower and upper), it is essential that you adjust the lower setting (SET1) first, then the upper setting (SET2).

The temperature inside the cabinet can be selected by adjusting the two thermostat values in the following way:

Adjusting the upper set temperature (SET2):

1. Press the  key for a second to display the upper set point code.
2. Then click on  to display the upper set point value.
3. Increase the value with  or decrease it with .
4. Hold down the  key to confirm the new value.

Adjusting the lower set temperature (SET1):

Press the key for a second and repeat the procedure described above.

Note: The cabinet is delivered with the set points pre-programmed at 53.6°F for the upper set point (SET2) and at 51.8°F for the lower set point (SET1). These parameters were set for optimal everyday use of your cabinet.

Recommended temperature range setting is between 50°F and 57°F.

TEMPERATURE ALARM

Two types of alarm can appear on the setting display:

- **HI** indicates that the temperature inside the cabinet is too high.
- **LO** indicates that the temperature is too low.

Both alarms mean that the cabinet is malfunctioning. The alarm signal automatically disappears once the temperature returns to normal.

Important: You will need to wait approximately 48 hours before you notice the effects of the temperature change.

CLEANING AND CARE

- Always unplug the wine cellar before cleaning.
- Do not use benzene, scrubbing brushes or chemical cleaners as these will damage the unit. Use only a mild, nonabrasive cleanser to clean the exterior of the cabinet.
- Clean the stainless steel door and handle by wiping with a warm water and baking soda solution. The solution should be about 2 tablespoons of baking soda to a quart of water.
- Wash the racks with a mild detergent solution.
- Always dry all the parts with a clean dry cloth before plugging the wine cellar back into the receptacle.

EVERYDAY CABINET CARE TIPS

The following few operations enable you to obtain optimum operation and an extended life cycle.

1 - Regularly remove dust (twice a year) from the condenser (black metal grill fastened to the back of your wine cabinet).

2 - Completely clean the inside of your wine cabinet once a year, taking care to ensure that you have unplugged and unloaded it (use water and a non-caustic cleaning product, and make sure to rinse well).

Hygrometry

Your cabinet is equipped with an exclusive system enabling the creation, inside your wine cabinet, of the correct humidity level required to perfectly seal the corks in your bottles. On installation, it is important to pour the equivalent of a small glass of water on the floor of the cabinet to start up the heat dynamic pump process. Thereafter, it is important to add water from time to time.

The long life of your wine cabinet depends on regular monitoring, especially of anything that may appear abnormal, and informing us of any anomalies found.

ENERGY-SAVING TIPS:

- Install your cabinet in an appropriate place and within the recommended temperature range.
- Keep the door open for as short a time as possible.
- Ensure that the door seal is in good condition and not damaged. If it is damaged, contact your Vinotemp dealer.

TROUBLESHOOTING

SYMPTOM	POSSIBLE CAUSE
Vibrations	<ul style="list-style-type: none"> • Check to make sure the wine cellar is on a level surface.
The door will not close properly.	<ul style="list-style-type: none"> • The wine cellar is not on a level surface. • The racks are out of position. • A bottle is too long.
Unit has no power.	<ul style="list-style-type: none"> • Check the wall outlet for power. Make sure the outlet is not controlled by a wall switch.
The inside temperature does not seem correct.	<ul style="list-style-type: none"> • Make sure the cooling vents are not obstructed. • The room may be too hot. If the ambient temperature is 90°F or higher, the unit can have difficulty chilling adequately. • When using the unit for the first time, it can take up to 24 hours to reach the desired temperature.
The unit does not operate.	<ul style="list-style-type: none"> • It may not be plugged into the wall socket. • Make sure the wall socket is functional by testing another electrical appliance in the power socket.
Power is ON but the unit will not cool.	<ul style="list-style-type: none"> • Allow at least 24 hours for the internal temperature to adjust. • If the room temperature is above 90°F, the unit can have difficulty cooling. Humidity does not affect the cooling ability of the unit. • To achieve accurate temperature control, the unit should not be used or operated in any of the following locations: <ul style="list-style-type: none"> ○ In a sunny place ○ In a room with poor air circulation such as a garage, closet, near another heat-producing appliance such as a dishwasher, oven or refrigerator. ○ With an outlet shared with a refrigerator, as the refrigerator will drain power from the wine cellar. ○ In a cabinet or closet. • Make sure the cooling vents are not obstructed. • If the lower compartment does not cool, check if the fan on the middle board is not running.

TERMS OF SALE AND WARRANTY

Vinotemp International ("Seller") and the person or entity that acquires these goods from Seller ("Purchaser") hereby fully agree to the following terms and conditions of the sale: Shipping fees are the responsibility of the Purchaser whether freight prepaid or freight collect. Seller assumes no responsibility for the goods sold to the Purchaser once the goods have left the Seller's premises, including, but not limited to, late delivery by the moving carrier, or for events caused by any difficulty carrier incurs in attempting to fit the goods into the Purchaser's place of business or residence due to the size of the goods or otherwise. Purchaser assumes all responsibility for delivery, payment of freight, access, measurement, installation, hook-up, wiring, moving and storage of the goods. The transportation of all goods is subject to the terms and conditions which the moving carrier imposes on Purchaser including, but not limited to, additional charges imposed per flight of stairs, and/or additional charges resulting from the carrier's inability to safely and/or adequately use the building elevator to lift the goods to an upper floor. Any claim for damages incurred during shipment by the carrier of the goods are insured and handled directly with the carrier and must be noted at time of delivery. Any damages due to manufacture defects will be handled directly with Vinotemp International, subject to the limited warranty.

All sales are final, and unless authorized in writing by the Seller, Purchaser may not return the goods, under any circumstance. If Purchaser refuses to accept the goods, under any circumstance, the Purchaser is liable for the return and cost of freight both ways, and if Seller does take back the goods, there will be a restocking charge that is 35% of the purchase price of the goods. (Product must be in original packaging). Built-to-Order products (including Cabinets, Racking, and Accessories) are non-returnable. Purchaser must notify Seller of non-conforming goods within four days of delivery, after which time all goods are deemed accepted. If an order has been placed and production has started, cancellation of your order will be a 15% charge.

If Purchaser tenders payment with a check that has insufficient funds (NSF), or stops payment on a check or credit card for any reason, Purchaser agrees to pay for all costs associated with the Seller's collection or litigation of such a claim, including without limitation extra damages, court costs and attorneys' fees. Finance charges begin the date of invoice. Collection fees plus NSF fee of \$50 will be added to your invoice, which you agree to promptly pay. Title to the goods does not pass until payment is received in full by Seller and Seller retains a security interest in the goods until they are paid for in full.

LIMITED WARRANTY: Seller warrants that the goods will be free of defects in materials and workmanship as follows: Furniture style (wood) wine cabinets: all cooling unit parts for a period of 5 (five) years; cabinetry and labor (uninstalled) for a period of 12 (twelve) months from date of sale. For the metal cabinet wine units: parts and labor for cooling system and cabinetry for a period of 12 (twelve) months from date of sale. Thermoelectric Units: 90 (ninety) days from the date of sale (including Wine Coolers, Beer Dispensers, Humidor, Portofino Wood Cellars, and Refrigerators). Wine-Mate Split Systems and installed products are parts only for 1 year, no labor. Other Wine-Mate Cooling Systems are 5 years parts, 1 year labor. Wine Accessories and Racking Systems are not warranted. For a scratch and dent/refurbished unit, warranty is 3 months from your dated invoice (parts for function only, not cosmetic). There is no warranty on parts purchased separately. Removal and re-installation of unit is not included in warranted labor. Purchaser's exclusive remedy is limited, at Seller's option; to repair or replace defective part[s] with either new or factory reconditioned part[s]. Purchaser is responsible for shipping the unit pre-paid to designated facility and Seller will pay return shipping charges in the continental United States for items repaired under warranty within 12 (twelve) months from date of sale. Since the natural variation in texture, density, grain, color, tone and shade of wood is unavoidable; Seller does not guarantee the texture, color, tone or shade of the wood: nor does seller guarantee the colorfastness of wood or against peeling, chipping, cracking or scratching. Note: Unfinished wood is subject to warping; all wood surfaces must be sealed before placing cellar into service. Improper placement of the unit will void the warranty. By Vinotemp in writing, any third party repair facility must be pre-approved before providing parts free of charge. This limited warranty does not cover damage due to such things as accident, misuse, abuse, mishandling, neglect, acts of God, fires, earthquakes, floods, high winds, government, war, riot or labor trouble, strikes, lockouts, delay of carrier, unauthorized repair, or any other cause beyond the control of the Seller, whether similar or dissimilar to the foregoing. Seller is not responsible for any damages caused to Purchaser's property resulting from the good. This limited warranty applies only inside the Continental US. (Alaska, Puerto Rico and Hawaii are not warranted.)

For Element Grills (via Element Products LLC), grills have a 1 year comprehensive parts warranty on entire product. Three years limited parts warranty covering the stainless burner and a thirty day limited parts warranty on grill accessories. If grill is defective and unused plus all packaging and parts are intact, we will either replace the grill or provide service to repair the grill. Returned product must accompany all original packaging and parts and is subject to our 35% restocking fee (and freight both ways).

With Wine-Mate products, if the customer calls and the product is "defective", you must obtain a letter from your qualified refrigeration technician at the customer's cost, to verify that the unit was installed properly, with proper ventilation and the unit is truly malfunctioning due to manufacture defect.

Purchaser understands and acknowledges that the goods sold here are wine cellars, cigar humidors, and/or other similar units which house wine or cigars. Purchaser assumes all risk of using these units, including risk of spoilage, humidity variations, temperature variations, leaks, fire, water damage, mold, mildew, dryness and similar and any other perils that might occur.

Seller is not responsible for incidental or consequential damages, and there are no warranties, expressed or implied, which extend beyond the Limited Warranty described above. The implied warranties of merchantability and of fitness for a particular purpose are hereby expressly disclaimed. Some states do not allow the exclusion of incidental or consequential damages, or a waiver of the implied warranties of fitness and/or merchantability, so the above limitations may not apply to you. This warranty gives you specific legal rights and you may also have other rights which vary from state to state.

In the event of any dispute between Seller and Purchaser arising out of or relating to these terms and conditions or to the goods sold generally, Purchaser must first file a written claim with Seller within ten days of the occurrence giving rise to the claim and wait an additional thirty days for a response before initiating any legal action. The sale and all terms are subject to California law. Any legal proceeding arising out of or relating to these terms and conditions or to the goods sold generally shall be brought solely and exclusively in the County of Los Angeles. In no event may Purchaser initiate any legal proceeding more than six months after the occurrence of the event giving rise to the dispute.

The above terms and conditions are the only ones governing this transaction and Seller makes no oral representations of any kind. These Terms and Conditions can only be modified in writing, signed by both Purchaser and Seller. 10/10

SERVICE & IMPORTANT NOTICE

Upon receipt of unit and inspection, the supply cord must be replaced if it is damaged. Contact our customer service at 1-800-777-8466.

The Manufacturer has a policy of continuous improvement on its products and reserves the right to change materials and specifications without notice.

WARNING:

**Please do not place the unit within reach of children.
For adult use only.**

Contact info@vinotemp.com with any questions or visit:

www.vinotemp.com



17621 S. Susana Road
Rancho Dominguez, CA 90221
www.vinotemp.com

Vinotemp is a registered trademark of Vinotemp International. All products, features, services, and information in this document are subject to change without notice. We cannot guarantee the accuracy of the contents of this document. We disclaim liability for errors, omissions, or future changes.

© 2011 Vinotemp International. All rights reserved.