

Comfort Contego User Manual

Please read the User Manual
before using this product.



Comfort Contego T900
Transmitter



Comfort Contego R900
Receiver

DO NOT USE the **COMFORT CONTEGO** if you have a **PACEMAKER** or other implanted device. The Comfort Contego could cause the pacemaker or other implanted device to malfunction and cause serious injury or death.



Comfort Contego is not to be used as a substitute to the hearing aids and should be used in accordance with the specifications and recommendations provided by your physician.

It is recommended that customers keep the volume control in the lowest position, when turning on the device.

Comfort Audio is not liable for damages arising from usage of the equipment not in accordance with the instructions provided by Comfort Audio. Comfort Audio shall not be liable for performance problems and/or damages caused in any way by customer's modification of any part of the equipment.

Industry Canada, Operation is subject to the following two conditions:

- (1) this device may not cause interference, and
- (2) this device must accept any interference, including interference that may cause undesired operation of the device.

Federal Communications Commission Statement, This device complies with part 15 of the FCC Rules. Operation is subject to the following two conditions:

- (1) this device may not cause harmful interference, and
- (2) this device must accept any interference received, including interference that may cause undesired operation.

WARNING!

Changes or modifications not expressly approved by the party responsible for compliance could void the user's authority to operate the equipment

NOTE:

This equipment has been tested and found to comply with the limits for a Class B digital device, pursuant to Part 15 of the FCC Rules. These limits are designed to provide reasonable protection against harmful interference in a residential installation. This equipment generates, uses and can radiate radio frequency energy and, if not installed and used in accordance with the instructions, may cause harmful interference to radio communications. However, there is no guarantee that interference will not occur in a particular installation. If this equipment does cause harmful interference to radio or television reception, which can be determined by turning the equipment off and on, the user is encouraged to try to correct the interference by one or more of the following measures:

- Reorient or relocate the receiving antenna.
- Increase the separation between the equipment and receiver.
- Connect the equipment into an outlet on a circuit different from that to which the receiver is connected.
- Consult the dealer or an experienced radio/TV technician for help.

Contents	Page
Introduction	4 - 5
This is included	6 - 7
Getting started	8 - 11
Charging	8
Functions - receiver	12 - 14
Functions - transmitter	14 - 15
Menu	16 - 17
Symbols receiver	18 - 19
Symbols transmitter	20 - 21
Radio range and channels	22
Using the neck loop/headphones	23
Areas of use	
Conversations	24
Lectures	25
In a shop	26
Meetings	27
Dinner	28
At home	29
In the car	30
Watching TV	31
Special functions	32
Troubleshooting	33
Safety instructions	34
Service, guarantee and technical data	35

Introduction

Congratulations on your choice of the Comfort Contego. In the bag you will find everything you need to improve your grasp of speech in all kinds of situations. It is easy to use and works regardless of whether you have a hearing aid or not. The sound is transmitted digitally which gives an extremely good speech reception. Comfort Contego is almost impossible to intercept as the receiver and transmitter are paired using a coded key. Please read through the instructions for use before you use the product.





For conversations
at home or at work



Watching TV



At a restaurant



With a directional
microphone on the
receiver.

This is included

Bag



Receiver - Contego R900

Transmitter - Contego T900



Sound Kit



Charger



Alternatives

Neck loop with
extension cable



or

Headphones



Earphones



Getting started

Charging

Comfort Contego contains a rechargeable battery. Charge the transmitter and the receiver for at least 4 hours before using them for the first time.

An empty battery takes about 4 hours to charge. When the battery is charged you can use the unit for up to 16 hours. The transmitter can be charged during use.

To charge:

When the battery is being charged the battery symbol on the display blinks. When the battery symbol is full Comfort Contego is fully charged and charging ceases. Changing the battery without the assistance of an authorized dealer will void the Limited Warranty.

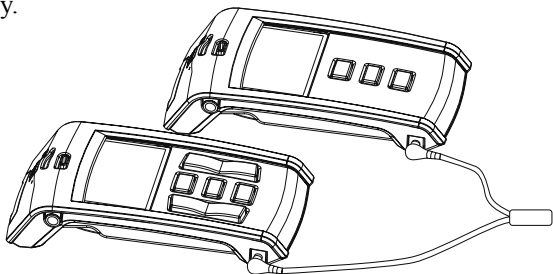

Use only the Comfort Audio AB charger that is supplied.

Starting to use the Comfort Contego

1. When the Comfort Contego is fully charged - start the receiver by pressing the button for about 2 seconds.

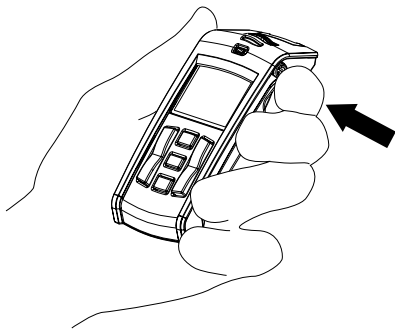

2. Then connect the neck loop and turn the hearing aid to the T position. Use the headphones instead of the neck loop if you don't use hearing aids.

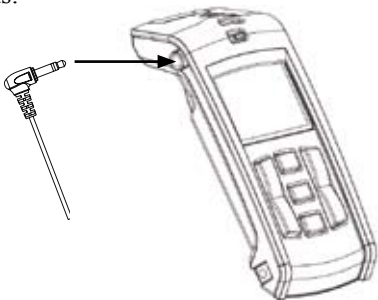

3. Picking up sound via the built in microphones in the receiver. Set the audio level by means of the right hand volume controller (see page 12) (Note! Start listening at a low volume. If the volume is not set on the lowest position, the sound could potentially cause harm to the customers' hearing.)

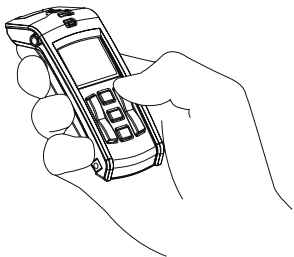

Select the directional or omni-directional microphone with the arrow buttons in the middle (see page 12). Place the receiver on a table or aim it at the person you want to listen to. Choose directional or omni-directional settings depending on the situation. Normally in noisy surroundings directional setting is preferred.

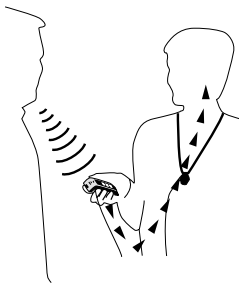
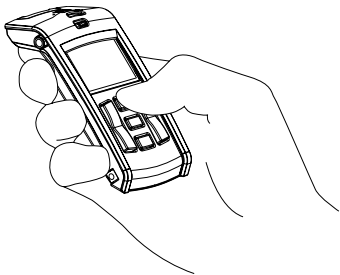

4. Picking up sound by means of transmitter.

When the distance between you and the speaker /sound source is longer, let the person you want to hear use the transmitter.

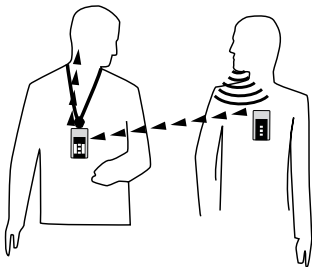

Set the audio level by means of the left hand volume controller.
(see page 12) (Note! Start listening at a low volume)

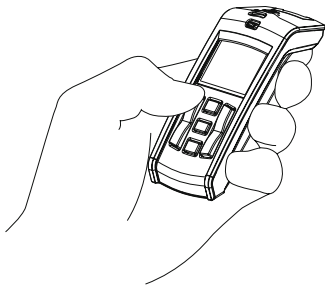

(When the transmitter or receiver is turned on, the most recent settings for volume and microphone type are automatically selected)

Functions - Receiver, Comfort Contego R900

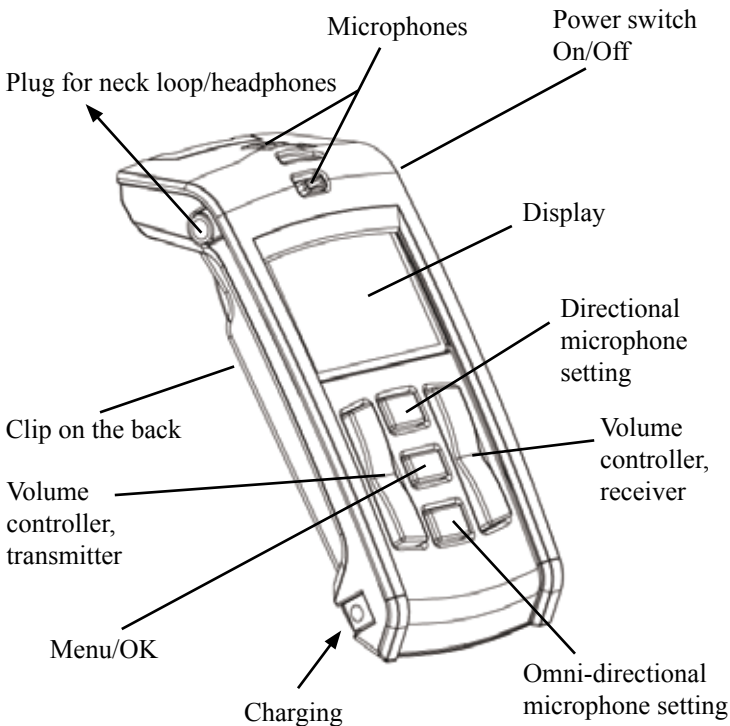

Functions R900

The most important functions can be accessed without needing to go into the menu. (For menu see page 16.)

Volume controller receiver (internal microphones)

By pressing the plus sign you increase the volume on the receiver microphone



By pressing the minus sign you decrease the volume on the receiver microphone



Directional microphone

With the uppermost arrow you select the directional microphone



Omni-directional microphone

With the lower arrow you select the omni-directional microphone



Functions Receiver R900

Volume controller (transmitter)

By pressing the plus sign you increase the volume from the transmitter microphone.



By pressing the minus sign you decrease the volume from the transmitter microphone.



Functions Transmitter T900

Line in unattached

Directional microphone

With the uppermost arrow you select the Uni-directional microphone.



Omni-directional microphone

With the lower arrow you select the omni-directional microphone.



Line in attached

By pressing the uppermost arrow you increase the line in amplification.

By pressing the lower arrow you decrease the line in amplification.

Functions - Transmitter, Comfort Contego T900

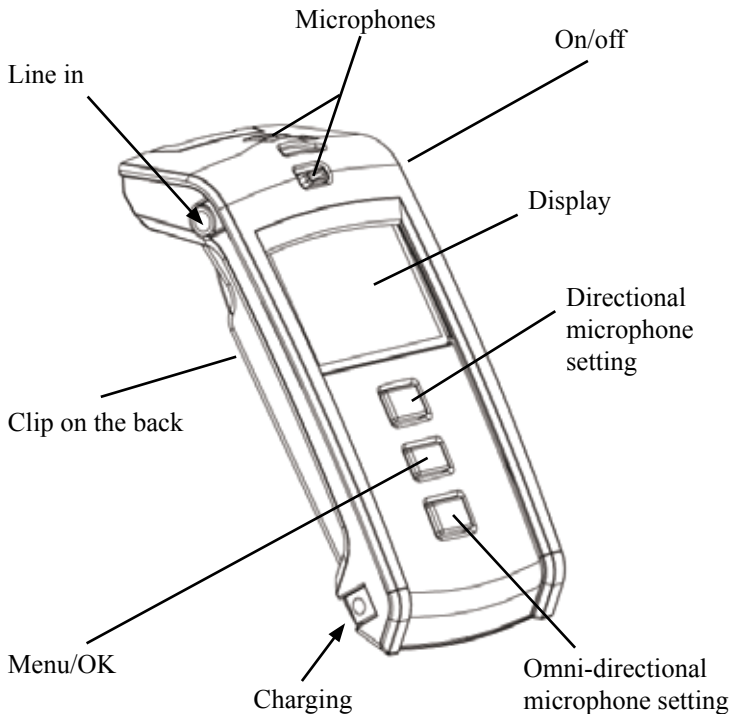

Menu Receiver and transmitter

The functions in the menus are the same for both the receiver and the transmitter.

Press and hold the Menu/OK button for a short moment to access the menu:

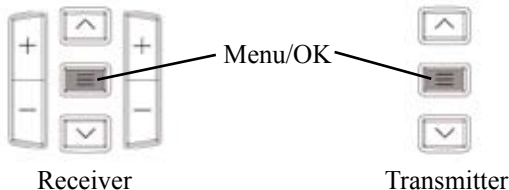

Choices displayed on the transmitter:

Back
Channel
Pairing
Line in
Language
Key lock

Choices on the receiver:

Back
Pairing
Language
Key lock

You select the function by navigating up or down with the arrow buttons

To make a selection, press Menu/OK
To return, also press Menu/OK

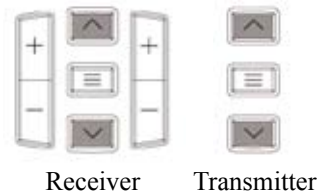

Channel settings

The transmitter and receiver are set on the same channels when you receive the product. To change channels choose Channel in the menu and press OK, navigate between the channels by using the arrows up and down. To choose a channel press OK.

Pairing

In order to use the receiver and the transmitter they must be paired. (When you receive them they are already paired). Confirm that both the transmitter and receiver are charged and ON. Press MENU key on the transmitter and receiver. Scroll to PAIR and press OK (Menu Key). A new menu will show. Press pair. The unit will display “Wait for receiver/transmitter”. Press OK on the transmitter. In a few seconds the Units will PAIR and display “Pairing Complete”.

Line in

Here you choose if you want to use a external sound source. When you receive the Contego it is on “Line in” (The microphone setting is only to be used if you use our accessory TV-microphone)

Language

Select the language with the arrows. Press OK.

Key lock

When you are in the menu selection “Lock Keys” and press Menu/OK you lock the keys. To unlock them press the up and down arrow keys simultaneously.

Display Symbols on the Receiver, Comfort Contego R900

Contego

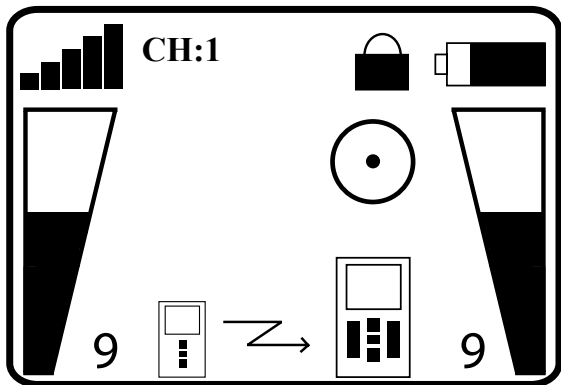

R900



Signal strength

Shows how strong the signal between the receiver and the transmitter is.



Battery status

Shows the current battery capacity.



Key Lock

When the padlock is showing the key lock is activated. (see page 17).



Volume transmitter

The bar display and the number beside it show the volume on the transmitter.



Volume receiver

The bar display and the number beside it show the volume on the receiver.



Directional microphone setting

With the directional microphone setting you receive a directional microphone aimed at a limited area.

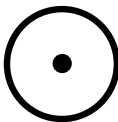

Omni-directional microphone setting

With the omni-directional microphone setting you can cover a larger area.

CH:1

Channel

The number shows which channel the receiver is set on. (The receiver and transmitter must be on the same channel in order to be able to work together.) When the exclamation mark “!” is displayed it means that you are transmitting on a frequency that you must apply for permission to use. (Comfort Audio is not liable for unauthorized use of radio waves, such as, but not limited to: interferences with police communication, or strategic communication, military installations etc.)

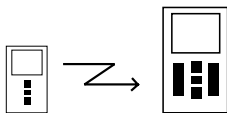

Transmission

Shows that there is contact between the receiver and the transmitter. If the receiver and transmitter are too near one another “Too close” is displayed

Display Symbols Transmitter, Contego T900

Contego

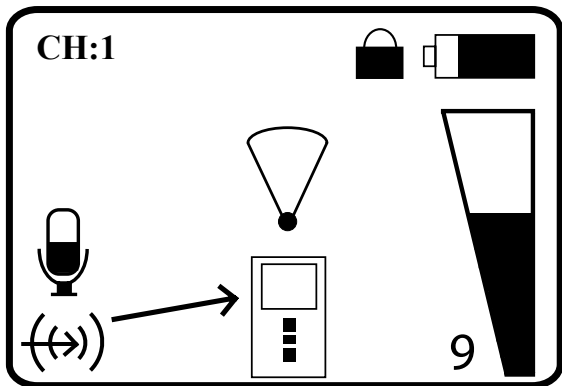

T900

CH:1

Channel

The number shows which channel the receiver is set on. When the exclamation mark “!” is displayed it means that you are transmitting on a frequency that you must apply for permission to use.



Key Lock

When the padlock is displayed the key lock is activated (see page 17)



Battery status

Shows the current battery capacity.



Directional microphone setting

With the directional microphone setting you receive a directional microphone aimed at a limited area.

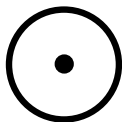

Omni-directional microphone setting

With the omni-directional microphone setting you can cover a larger area. This is perfect for a meeting or a dinner with several people.



Line in / Microphone

Line in is for listening to an external sound source, for example a TV or a stereo. When the cable is connected, an arrow is shown between the symbol and the transmitter.



Amplification Line in

The bar display and the number beside it show the amplification of the external sound source.

Radio range and channels

The aerials for the transmitter and receiver are built in. The range is up to 25 meters. This can vary depending on the kind of environment you are in.

Like all radio transmitters Comfort Contego communicates on special channels. If you use two transmitters on the same channel there will be an interference.

Other electronic equipment can also interfere with the radio transmissions.

The channel that you use in your country is perhaps not permitted abroad. Always get in touch with your hearing aid provider in your country in order to find out which channels are permitted in different countries.

Comfort Audio is not liable for unauthorized use of radio waves, such as, but not limited to: interferences with police communication, or strategic communication, military installations etc.

Neck loop

With a neck loop connected to the receiver you can listen with a hearing aid set on the T position.

Connect the neck loop or the extension cable to the receiver:

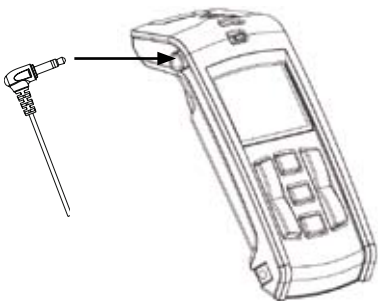

Injuries may occur if loop gets caught. Keep the neck loop away from objects representing a danger like moving machineries, steering wheel while driving, elevator doors etc. Do not use the neck loop during sport activities or play.

Headphones or earphones

Headphones or earphones can be connected in the same way as described above.

Areas of use - Choosing the microphone setting

Conversations

Put the transmitter on the person you want to listen to. Select the directional setting on the transmitter and aim it at the person's mouth. Use the receiver with headphones or a hearing aid to listen. With the help of the extension cable you can have the receiver in your pocket.



Lectures

At a lecture you put the transmitter on the lecturer and use the receiver to listen.

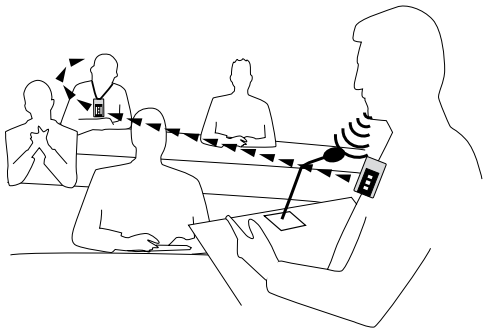

You can also listen to the people next to you with the help of the receiver.

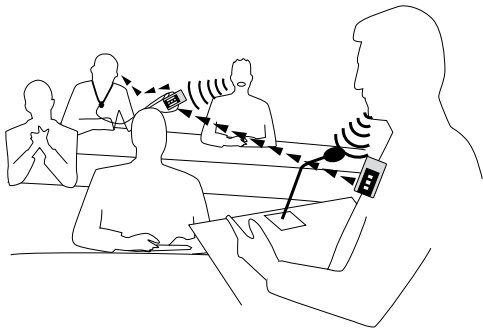

In a shop - short distances

When the distance between you and the person you want to hear is short or it is just a quick meeting, you can use the receiver on the directional setting and aim it at the person you want to hear. In a café or similar situation you can also place the receiver on the table and listen.

This is an easy and simple way to use the Comfort Contego.

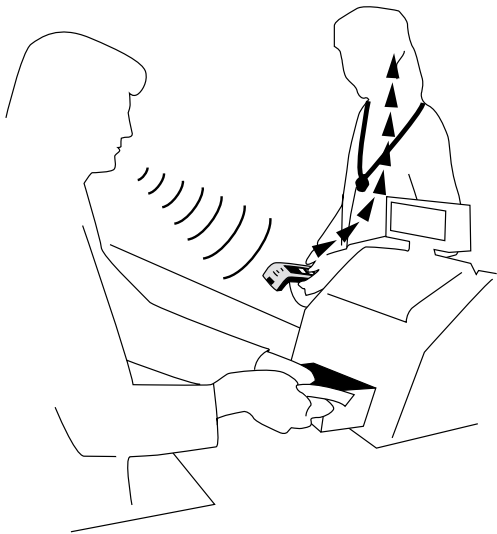

Meetings

In a meeting with more than two people you put the transmitter in its omni-directional setting on the table. The receiver can also be placed on the table in order to listen to those nearest you. You use the receiver with headphones or neck loop and hearing aid to listen.

On a one-to-one conversation you set the transmitter to the directional setting on the other person and you use the receiver to listen.

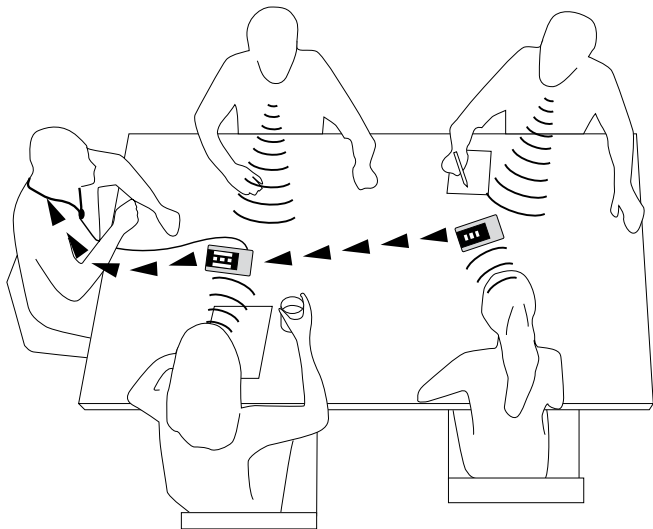

Dinner

At a dinner with more than two people put the transmitter in its omni-directional setting on the table. You use the receiver to listen with.

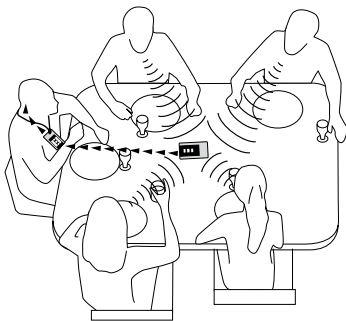

On a one-to-one conversation put the transmitter on the table or on the person you want to hear.

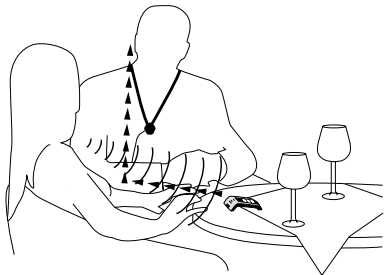

At home

Put the transmitter on the person you want to hear. Set it to omnidirectional with the microphone aimed upwards. Use the receiver to listen.



In the car

In a car it is almost always noisy. Regardless of whether you are a passenger or the driver you can hear what others in the car have to say with the help of Comfort Contego. Put the transmitter on the person you want to hear (Set it to directional with the microphone aimed upwards.) Use the receiver to listen.

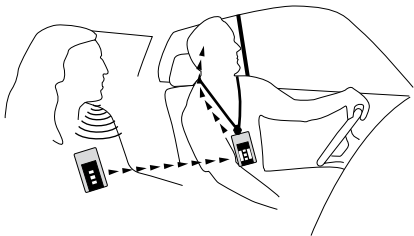

NOTE!

The use of headphones or earphones while driving a car or any other vehicle may limit or prevent the perception of surrounding noises and cause accidents.

If there are more people in the car you can let the people on the backseat use the transmitter. The person you want to hear in the front seat uses the receiver. You listen by using headphones or neck loop and hearing aid.

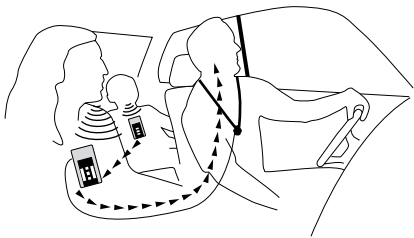

Watching TV

In order to be able to hear the TV or other sources of sound you can use the sound kit. You can then listen with the receiver.

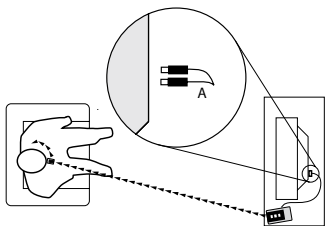

Connect the cable (A) between the TV and the socket on the Contego transmitter (T900). (Make sure the transmitter is set on “Line in”)

With the help of the built in microphone in the receiver you can also listen to people sitting next to you on the sofa.

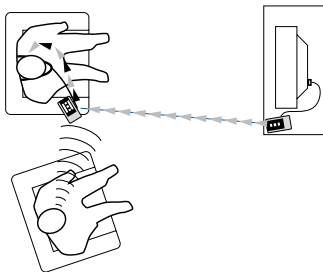

Special functions

Add a receiver / more receivers

If you want to use more than one receiver to listen with this is not a problem (e.g. during a guided tour.) In order to add a receiver go into the menu on the extra receiver, Choose Pair. Then go into the menu of the transmitter. Choose Pair and press OK. Pair complete! The new receiver can then be used to listen with.

- Tip:
- More than one receiver can be paired at the same time.
 - Instead of using the transmitter menu you can pair by pushing two quick times on the menu button on the transmitter.

Troubleshooting

Transmitter and receiver do not start.

Charge the transmitter and the receiver. Remember that you must hold the ON/OFF button in for 2 seconds in order to start Comfort Contego. If it still does not work - check the charger is connected to the mains. Contact your retailer to change the battery.

Poor speech reception

The distance between the transmitter and the receiver is too long. The distance between the microphone and the person speaking can also be too long.

Poor range and interference

In certain environments consisting of concrete, iron and metal plates, the range can be reduced. There can also be interfering equipment nearby. Change channel.

If you change channel on the transmitter the receiver must be on and within the transmitters range to follow the channel switch.

NOTE

If you use a hearing aid make sure that it is working and that it is in the T setting. Always make sure that the receiver and the transmitter are paired.

Important Safety Instructions

Not following the Important Safety Instructions, or trying to repair and/or tampering the Equipment without the assistance of an authorized technician will void the Limited Warranty. Comfort Audio is not liable for any damages arising out of such unauthorized uses, repairs, and/or tampering.

- 1) Read these instructions.
- 2) Keep these instructions.
- 3) Heed all warnings.
- 4) Follow all instructions.
- 5) Do not use this apparatus near water, it may damage the product.
- 6) Clean only with dry cloth, otherwise you could damage the product.
- 7) Install in accordance with the manufacturer's instructions. If not, it may damage the product.
- 8) Do not use or install near any heat sources such as radiators, heat registers, stoves, or other apparatus (including amplifiers) that produce heat.
- 9) Protect the power cord from being walked on or pinched particularly at plugs, convenience receptacles, and the point where they exit from the apparatus.
- 10) Only use attachments/accessories specified by the manufacturer.
- 11) Unplug this apparatus during lightning storms or when unused for long periods of time.
- 12) Refer all servicing to qualified service personnel. Servicing is required when the apparatus has been damaged in any way, such as power-supply cord or plug is damaged, liquid has been spilled or objects have fallen into the apparatus, the apparatus has been exposed to rain or moisture, does not operate normally, or has been dropped.



Service and guarantee

Comfort Audio AB provides a comprehensive guarantee for two years after the date of delivery. This covers all manufacturing faults. Headphones, earbuds, cables and batteries are warranted under normal use for thirty days from date of purchase. Faults caused by careless use or opening the Comfort Contego are not covered by the guarantee.

Accessories and spare parts

Spare parts and accessories can be ordered (see pages 6-7 for pictures.) You are always welcome to contact your nearest retailer if there is anything you are unsure about.

The weights, dimensions, capacities, performance ratings and other data in Comfort Audio's brochures, prospectus, circulars, advertisements, price lists and instructions sheets are mentioned only as general information. They are only approximate and shall not bind Comfort Audio.

Technical data

Type of transmitter	Digital modulation, with encryption
Range	- 75 feet
Size	0,87 x 1,77 x 3,86 inches
Weight	2,1 oz
Frequency range	904 - 926 MHz
Channels	38
Antenna	Built in
Operating time	- 16 hours
Battery	Rechargeable Li-Ion
Charging time	4 hours
Microphones	Built in, directional and omni-directional
Input	Line in / Microphone

Manufactured by:



Comfort Audio AB Box 154 SE-301 05 Halmstad, Sweden
Tel +46 35 - 15 23 00 Fax +46 35 - 15 23 23
usa@comfortaudio.com www.comfortaudio.us