

RIDGID®

OPERATOR'S MANUAL

18 GAUGE BRAD NAILER

R138BNA

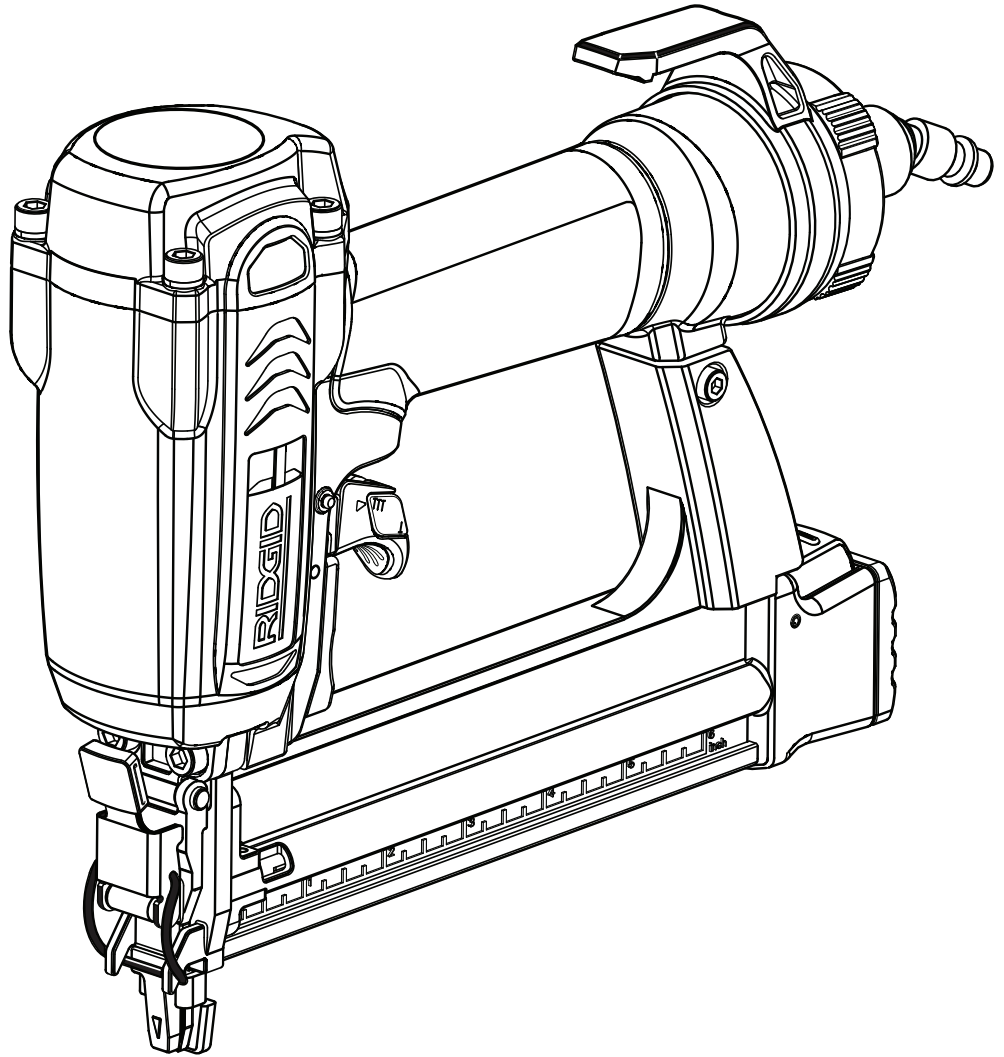

Your brad nailer has been engineered and manufactured to our high standards for dependability, ease of operation, and operator safety. When properly cared for, it will give you years of rugged, trouble-free performance.

⚠ WARNING:

To reduce the risk of injury, the user must read and understand the operator's manual before using this product.

Thank you for buying a RIDGID® product.

SAVE THIS MANUAL FOR FUTURE REFERENCE

TABLE OF CONTENTS

■ Introduction.....	2
■ General Safety Rules	3
■ Specific Safety Rules.....	4-5
■ Symbols.....	6
■ Glossary of Terms.....	7
■ Features.....	8-9
■ Assembly	9
■ Operation.....	10-16
■ Maintenance	17-18
■ Accessories	19
■ Troubleshooting	19
■ Warranty	21
■ Customer Service Information.....	Back page

INTRODUCTION

This tool has many features for making its use more pleasant and enjoyable. Safety, performance, and dependability have been given top priority in the design of this product making it easy to maintain and operate.

GENERAL SAFETY RULES



DANGER:

READ AND UNDERSTAND TOOL LABELS AND MANUAL. Failure to follow warnings could result in DEATH or SERIOUS INJURY.

SAVE THESE INSTRUCTIONS

WORK AREA

- **Keep your work area clean and well lit.** Cluttered benches and dark areas invite accidents.
- **Do not operate power tools in explosive atmospheres, such as in the presence of flammable liquids, gases, or dust.** Power tools create sparks which may ignite the dust or fumes.
- **Keep bystanders, children, and visitors away while operating a power tool.** Distractions can cause you to lose control.

PERSONAL SAFETY

- **Eye protection which conforms to ANSI specifications and provides protection against flying particles both from the FRONT and SIDE should ALWAYS be worn by the operator and others in the work area when loading, operating or servicing this tool.** Eye protection is required to guard against flying fasteners and debris, which could cause severe eye injury.
- **The employer and/or user must ensure that proper eye protection is worn.** We recommend Wide Vision Safety Mask for use over eyeglasses or standard safety glasses that provide protection against flying particles both from the front and side. Always use eye protection which is marked to comply with ANSI Z87.1.
- **Additional safety protection will be required in some environments.** For example, the working area may include exposure to noise level which can lead to hearing damage. The employer and user must ensure that any necessary hearing protection is provided and used by the operator and others in the work area. Some environments will require the use of head protection equipment. When required, the employer and user must ensure that head protection conforming to ANSI Z89.1-1997 is used.
- **Stay alert, watch what you are doing and use common sense when operating a power tool. Do not use tool while tired or under the influence of drugs, alcohol, or medication.** A moment of inattention while operating power tools may result in serious personal injury.
- **Dress properly. Do not wear loose clothing or jewelry. Contain long hair. Keep your hair, clothing, and gloves away from moving parts.** Loose clothes, jewelry, or long hair can be caught in moving parts.

- **Keep fingers away from trigger when not driving fasteners to avoid accidental firing.**
- **Do not overreach. Keep proper footing and balance at all times.** Proper footing and balance enables better control of the tool in unexpected situations.
- **Use safety equipment. Always wear eye protection.** Dust mask, nonskid safety shoes, hard hat, or hearing protection must be used for appropriate conditions.
- **Do not use on a ladder or unstable support.** Stable footing on a solid surface enables better control of the tool in unexpected situations.

TOOL USE AND CARE

- **Do not force tool. Use the correct tool for your application.** The correct tool will do the job better and safer at the rate for which it is designed.
- **Do not use tool if trigger does not actuate properly.** Any tool that cannot be controlled with the trigger is dangerous and must be repaired.
- **Check operation of the workpiece contact mechanism frequently.** Do not use the tool if the workpiece contact mechanism is not working correctly as accidental driving of a fastener may result. Do not interfere with the proper operation of the workpiece contact mechanism.
- **Store idle tools out of the reach of children and other untrained persons.** Tools are dangerous in the hands of untrained users.
- **Maintain tools with care.** Follow maintenance instructions. Properly maintained tools are easier to control.
- **Check for misalignment or binding of moving parts, breakage of parts, and any other condition that may affect the tool's operation. If damaged, have the tool serviced before using.** Many accidents are caused by poorly maintained tools.
- **Use only fasteners that are recommended for your model.**
- **Keep the tool and its handle dry, clean and free from oil and grease.** Always use a clean cloth when cleaning. Never use brake fluids, gasoline, petroleum-based products, or any strong solvents to clean your tool. Following this rule will reduce the risk of loss of control and deterioration of the enclosure plastic.

SERVICE

- **Tool service must be performed only by qualified repair personnel.** Service or maintenance performed by unqualified personnel may result in a risk of injury.
- **When servicing a tool, use only identical replacement parts. Follow instructions in the Maintenance section of this manual.** Use of unauthorized parts or failure to follow Maintenance instructions may create a risk of injury.

SPECIFIC SAFETY RULES

- **Know your pneumatic tool.** Read operator's manual carefully. Learn its applications and limitations, as well as the specific potential hazards related to this tool. Following this rule will reduce the risk of electric shock, fire, or serious injury.
- **Always wear safety glasses with side shields.** Everyday glasses have only impact resistant lenses. They are NOT safety glasses. Following this rule will reduce the risk of eye injury.
- **Protect your lungs.** Wear a face or dust mask if the operation is dusty. Following this rule will reduce the risk of serious personal injury.
- **Protect your hearing.** Wear hearing protection during extended periods of operation. Following this rule will reduce the risk of serious personal injury.
- **Make sure the hose is free of obstructions or snags.** Entangled or snarled hoses can cause loss of balance or footing and may become damaged.
- **Use the tool only for its intended use.** Do not discharge fasteners into open air.
- **Use the pneumatic tool only for the purpose for which it was designed.**
- **Use only the fasteners recommended for this tool.** Use of the wrong fasteners could result in poor fastener feeding, jammed fasteners, and nails leaving the tool at erratic angles. If fasteners are not feeding smoothly and properly, discontinue their use immediately. Jammed and improperly feeding fasteners could result in serious personal injury.
- **Never use this tool in a manner that could cause a fastener to be directed toward anything other than the workpiece.**
- **Do not use the tool as a hammer.**
- **Always carry the tool by the handle.** Never carry the tool by the air hose.
- **Do not alter or modify this tool from the original design or function without approval from the manufacturer.**
- **Always be aware that misuse and improper handling of this tool can cause injury to yourself and others.**
- **Never clamp or tape the trigger or workpiece contact in an actuated position.**
- **Never leave a tool unattended with the air hose attached.**
- **Do not operate this tool if it does not contain a legible warning label.**
- **Do not continue to use a tool that leaks air or does not function properly.**

OPERATION

- **Always assume that the tool contains fasteners.**
- **Do not carry the tool from place to place holding the trigger.** Accidental discharge could result.
- **Always handle the tool with care:**
 - Respect the tool as a working implement.
 - Never engage in horseplay.
 - Never pull the trigger unless nose is directed toward the work.
 - Keep others a safe distance from the tool while tool is in operation as accidental actuation may occur, possibly causing injury.
- **Choice of triggering method is important. Check manual for triggering options.**
- **Pneumatic tools are designed for single-hand use.** Do not hold the tool by the front of the magazine. Do not put hands, head, or other parts of your body near the bottom of the magazine where the nail exits the tool, as serious personal injury could result.
- **Do not point the tool toward yourself or anyone whether it contains fasteners or not.**
- **Do not actuate the tool unless you intend to drive a fastener into the workpiece.**
- **Always ensure that the workpiece contact is fully positioned above the workpiece.** Positioning the workpiece contact only partially above the workpiece could cause the fastener to miss the workpiece completely and result in serious personal injury.
- **Do not drive fasteners near edge of material.** The workpiece may split causing the fastener to ricochet, injuring you or a co-worker. Be aware that the nail may follow the grain of the wood, causing it to protrude unexpectedly from the side of the work material.
- **Keep hands and body parts clear of immediate work area.** Hold workpiece with clamps when necessary to keep hands and body out of potential harm. Be sure the workpiece is properly secured before pressing the nailer against the material. The workpiece contact may cause the work material to shift unexpectedly.
- **Keep face and body parts away from back of the tool cap when working in restricted areas.** Sudden recoil can result in impact to the body, especially when nailing into hard or dense material.

SPECIFIC SAFETY RULES

- **During normal use the tool will recoil immediately after driving a fastener. This is a normal function of the tool.** Do not attempt to prevent the recoil by holding the nailer against the work. Restriction to the recoil can result in a second fastener being driven from the nailer. Grip the handle firmly, let the tool do the work and do not place second hand on top of tool or near exhaust at any time. Failure to heed this warning can result in serious personal injury.
- **Do not drive fasteners on top of other fasteners or with the tool at an overly steep angle as this may cause deflection of fasteners which could cause injury.**
- **Do not drive fasteners close to the edge of the workpiece as the wood may split, allowing the fastener to be deflected possibly causing injury.**

AIR SUPPLY AND CONNECTIONS

- **Do not use oxygen, combustible gases or bottled gases as a power source for this tool as tool will explode, possibly causing injury or death.**
- **Do not use with an air compressor which can potentially exceed 200 psi as tool may burst, possibly causing injury.**
- **The connector on the tool must not hold pressure when air supply is disconnected.** If an incorrect fitting is used, the tool can remain charged with air after disconnecting and thus will be able to drive a fastener even after the air line is disconnected, possibly causing injury.

Always disconnect air supply:

- Before making adjustments
- When servicing the tool
- When clearing a jam
- When tool is not in use
- When moving to a different work area, as accidental actuation may occur, possibly causing injury.

LOADING TOOL

- **Do not load the tool with fasteners when any one of the operating controls is activated.**

When loading tool:







- **Never place a hand or any part of body in fastener discharge area of tool.**
- **Never point tool at anyone.**
- **Do not pull the trigger or depress the workpiece contact as accidental actuation may occur, possibly causing injury.**

SAVE THESE INSTRUCTIONS



- Refer to them frequently and use them to instruct others who may use this tool. If you loan someone this tool, loan them these instructions also.

SYMBOLS

Some of the following symbols may be used on this tool. Please study them and learn their meaning. Proper interpretation of these symbols will allow you to operate the tool better and safer.

SYMBOL	NAME	DESIGNATION/EXPLANATION
	Read The Operator's Manual	To reduce the risk of injury, user must read and understand operator's manual before using this product
	Eye Protection	Always wear safety goggles or safety glasses with side shields and, as necessary, a full face shield when operating this product.
	Eye, Ear and Head Protection	Always wear other personal protective equipment such as hearing protection and a hard hat when needed.
	Keep Hands Away	Keep hands and body away from the discharge area of the tool.
	Safety Alert	Precautions that involve your safety.
	Hot Surface	To reduce the risk of injury or damage, avoid contact with any hot surface.

The following signal words and meanings are intended to explain the levels of risk associated with this product.

SYMBOL	SIGNAL	MEANING
	DANGER:	Indicates an imminently hazardous situation, which, if not avoided, will result in death or serious injury.
	WARNING:	Indicates a potentially hazardous situation, which, if not avoided, could result in death or serious injury.
	CAUTION:	Indicates a potentially hazardous situation, which, if not avoided, may result in minor or moderate injury
	CAUTION:	(Without Safety Alert Symbol) Indicates a situation that may result in property damage.

SERVICE

Servicing requires extreme care and knowledge and should be performed only by a qualified service technician. For service we suggest you return the product to your nearest **AUTHORIZED SERVICE CENTER** for repair. When servicing, use only identical replacement parts.



WARNING:

To avoid serious personal injury, do not attempt to use this product until you read thoroughly and understand completely the operator's manual. If you do not understand the warnings and instructions in the operator's manual, do not use this product. Call RIDGID® customer service for assistance.



WARNING:



The operation of any power tool can result in foreign objects being thrown into your eyes, which can result in severe eye damage. Before beginning power tool operation, always wear safety goggles or safety glasses with side shields and, when needed, a full face shield. We recommend Wide Vision Safety Mask for use over eyeglasses or standard safety glasses with side shields. Always use eye protection which is marked to comply with ANSI Z87.1.

SAVE THESE INSTRUCTIONS

GLOSSARY OF TERMS

Activate (operating controls)

To move an operating control so that it is in a position that allows the tool to be actuated or that satisfies one requirement for the tool to be actuated.

Actuate (tool)

To cause movement of the tool component(s) intended to drive a fastener.

Actuation system

The use of a trigger, workpiece contact and/or other operating control, separately or in some combination or sequence, to actuate the tool.

- **Single sequential actuation**

An actuation system in which there is more than one operating control and the operating controls must be activated in a specific sequence to actuate the tool. Additional actuation can occur when a specific operating control, other than a workpiece contact, is released and re-activated.

- **Contact actuation**

An actuation system in which there is more than one operating control and the operating controls can be activated in any sequence to actuate the tool. Additional actuation can occur when any operating control is released and re-activated.

Air inlet port

In an air tool, the opening to which the compressed air supply is connected, usually by means of a threaded fitting.

Fastener

A staple, pin, brad, nail, or other fastening device which is designed and manufactured for use in the tools within the scope of this standard.

Jam

An obstruction in the feed or drive areas of the tool.

Maximum air pressure

The maximum allowable pressure of the compressed air, as specified by the manufacturer, for operating a tool.

Operating control

A control that separately, or as part of an actuation system, can cause the actuation of a tool.

Trigger

A tool operating control activated by a tool operator's fingers.

Workpiece

The intended object into which a fastener is to be driven by a tool.

Workpiece contact

An operating control element or assembly on the tool intended to be activated by the material to be fastened.

FEATURES

PRODUCT SPECIFICATIONS

Operating Pressure	70-120 psi	Air Inlet	1/4 in. NPT
Fastener Type.....	18 gauge brad nails	Weighted sound impulse power level	86.9 dBA
Fastener Range	5/8 in. to 1-3/8 in.	Emission sound pressure level.....	73.9 dBA
Magazine Capacity.....	100 brad nails	Vibration	2.28 m/s ²
Air Consumption	0.046 ft ³ /cycle at 100 psi	Weight	2.6 lbs.

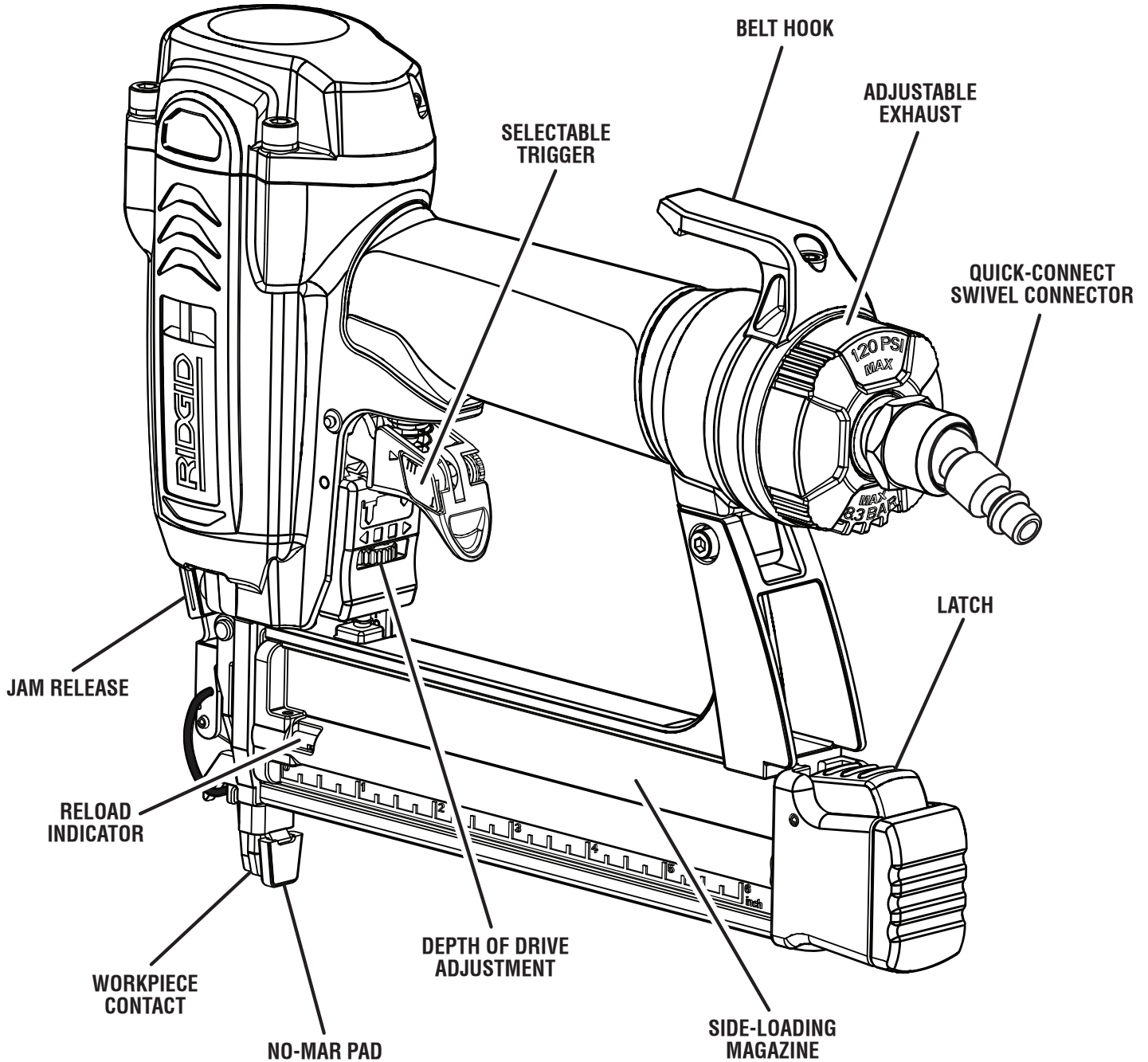

Fig. 1

FEATURES

KNOW YOUR BRAD NAILER

See Figure 1.

The safe use of this product requires an understanding of the information on the tool and in this operator's manual as well as a knowledge of the project you are attempting. Before use of this product, familiarize yourself with all operating features and safety rules.

ADJUSTABLE EXHAUST

The exhaust can be adjusted to a variety of positions depending on operator preference.

BELT HOOK

The hook will rotate to either side of the tool and can be used to hang the tool from a belt when disconnected and not in use.

CONSTRUCTION RULER

A construction ruler located along the left side of the magazine allows the operator to make quick measurements while working.

DEPTH OF DRIVE ADJUSTMENT

The tool-free depth of drive adjustment lets the operator select precise driving depth of the fastener.

IN-HANDLE AIR FILTER

The self-cleaning in-handle air filter helps keep debris out to extend the life of the tool.

JAM RELEASE

A tool-free jam release is provided for ease in clearing infrequent jams.

NO-MAR PAD

The no-mar pad prevents marring and denting when using the tool on softer woods.

OIL-FREE DESIGN

The oil-free design of the tool eliminates daily oiling and prevents oil splattering on work surfaces.

OVERMOLD GRIP AND TRIGGER

The overmold grip and trigger offer increased comfort and control of the tool.

QUICK-CONNECT SWIVEL CONNECTOR

The quick-connect swivel connector helps prevent hose tangles.

RELOAD INDICATOR

The reload indicator shows whether the magazine is running low on fasteners.

SELECTABLE TRIGGER

The selectable trigger lets the operator choose between Contact Actuation for higher productivity and Single Sequential Actuation for precise fastener placement.

SIDE-LOADING MAGAZINE

The side-loading magazine allows easy three-step reloading of fasteners.

ASSEMBLY

UNPACKING

This product has been shipped completely assembled.

- Carefully remove the tool and any accessories from the box. Make sure that all items listed in the packing list are included.
- Inspect the tool carefully to make sure no breakage or damage occurred during shipping.
- Do not discard the packing material until you have carefully inspected and satisfactorily operated the tool.
- If any parts are damaged or missing, please call 1-866-539-1710 for assistance.

PACKING LIST

Brad Nailer

Case

Sample Fasteners

Eye Protection

Hex Keys (3 mm and 4 mm)

Fastener Guide

Operator's Manual

WARNING:

If any parts are damaged or missing, do not operate this tool until the parts are replaced. Failure to heed this warning could result in possible serious personal injury.

WARNING:

Do not attempt to modify this tool or create accessories not recommended for use with this tool. Any such alteration or modification is misuse and could result in a hazardous condition leading to possible serious personal injury.

OPERATION



DANGER:

Do not use oxygen, combustible gases or bottled gases as a power source for this tool. The tool will explode and cause death or serious injury.



WARNING:

Do not allow familiarity with tools to make you careless. Remember that a careless fraction of a second is sufficient to inflict severe injury.



WARNING:

Always wear safety goggles or safety glasses with side shields when operating tools. Failure to do so could result in objects being thrown into your eyes resulting in possible serious injury.



WARNING:

Disconnect the tool from the air supply before leaving the work area, moving the tool to another location, or handing the tool to another person. Failure to do so could result in serious personal injury.



WARNING:

Always wear eye protection. Eye protection does not fit all operators in the same way. Make sure the eye protection chosen has side shields or provides protection from flying debris both from the front and sides.

APPLICATIONS

You may use this tool for the purposes listed below:

- Finish and Trim (interior and exterior)
- Decorative Trim
- Book Cases
- Baseboard
- Cabinets
- Case Backs
- Drawers
- Molding
- Mirror and Picture Frames
- Paneling
- Shoe & Base Moldings
- Staircases
- Upholstery Trim Panels
- Wainscoting
- Window Beading
- Chair Rail
- Furniture Frames
- Lattice Strip Molding
- Nailable Plastic Parts
- Crafts

OPERATION

NO-MAR PAD

See Figure 2.

The no-mar pad attached to the nose of the tool helps prevent marring and denting when working with softer woods.

⚠ WARNING:

Disconnect the tool from the air supply before removing or replacing the no-mar pad. Failure to do so could result in serious personal injury.

The pad can be removed by pulling it down and away from the nose. To replace the pad, fit it into place over the nose and push up to reset.

On-board storage for the pad is located on the magazine of the tool. An extra no-mar pad is provided in the on-board storage area.

ADJUSTING THE EXHAUST

See Figure 3.

The adjustable exhaust on the end cap of the tool allows the operator to direct the exhaust according to operator preference. To adjust, turn the exhaust cap until the exhaust blows in the desired direction.

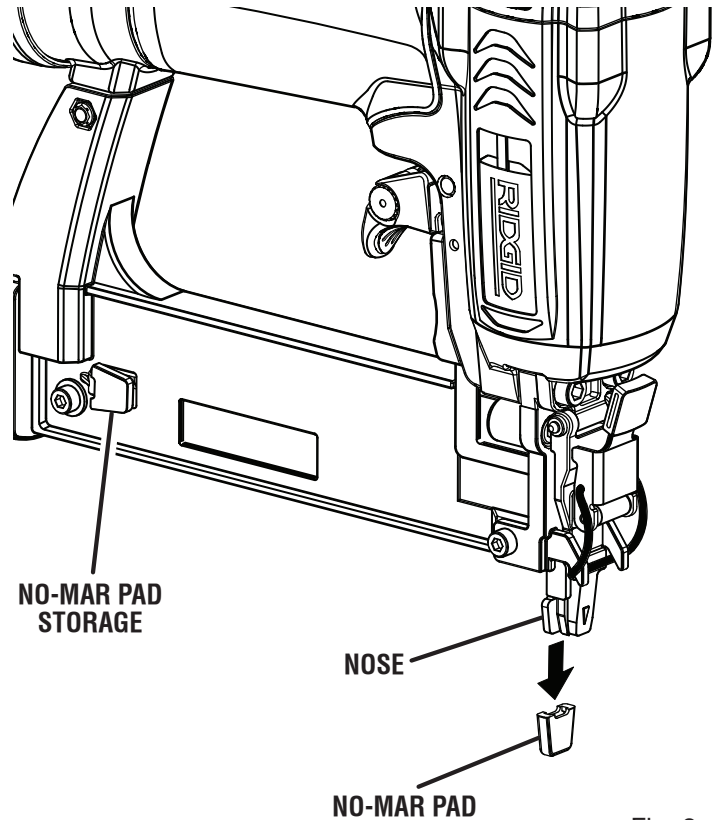

Fig. 2

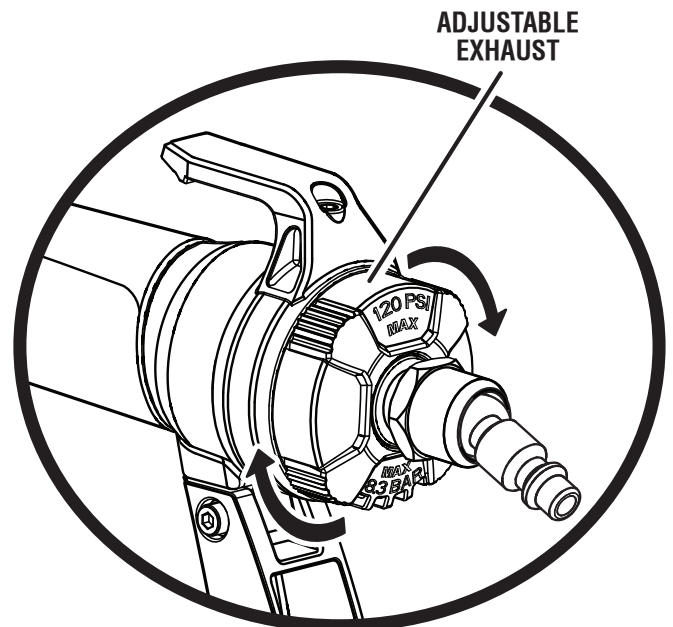

Fig. 3

OPERATION

⚠ WARNING:

Disconnect the tool from the air supply before leaving the work area, moving the tool to another location, or handing the tool to another person. Failure to do so could result in serious personal injury.

CONNECTING THE TOOL TO AN AIR SUPPLY

See Figure 4.

⚠ DANGER:

Do not use oxygen, combustible gases or bottled gases as a power source for this tool. The tool will explode and cause death or serious injury.

This tool is designed to operate on clean, dry compressed air at regulated pressures between 70 and 120 psi . The correct air pressure is the lowest pressure that will do the job.

NOTE: Air pressure that is higher than 120 psi may damage the tool.

The tool and air hose must have a hose coupling that allows all pressure to be removed from the tool when the coupling is disconnected.

⚠ WARNING:

Always use a coupling that discharges all the compressed air in the tool at the time the fitting or hose coupling is disconnected. Using a coupling that does not discharge the compressed air could cause unintended operation and serious personal injury.

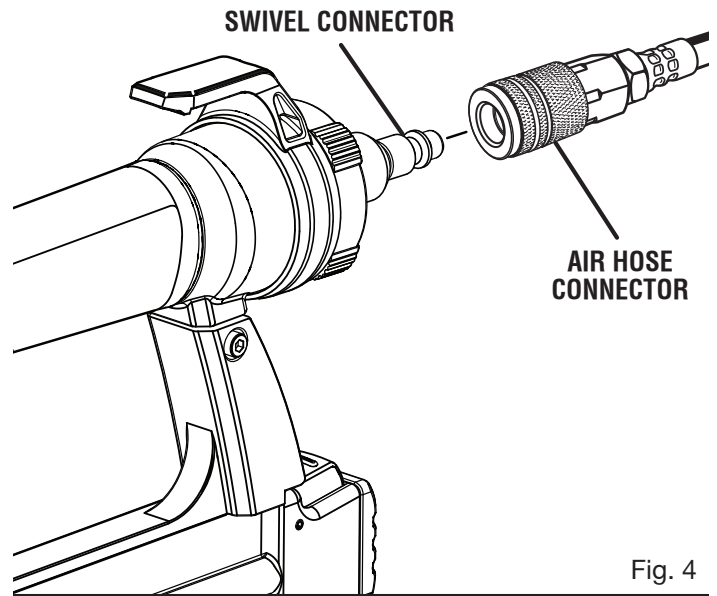

Fig. 4

⚠ WARNING:

Do not climb rigging or scaffolding while carrying a tool that is connected to an air hose. Doing so could result in serious personal injury.

Connect the tool to the air supply with a 1/4 in. female quick connector.

⚠ WARNING:

Disconnect the tool from the air supply before leaving the work area, moving the tool to another location, or handing the tool to another person. Failure to do so could result in serious personal injury.

OPERATION

LOADING THE TOOL WITH NAILS

See Figure 5.

- Connect the tool to the air supply.

WARNING:

The tool's driving mechanism may cycle when the tool is first connected to the air supply. Always connect the tool to the air supply before loading nails to prevent injury from unintended cycling. Always make sure the tool's magazine is empty at the beginning of each work session, before connecting to an air supply.

- With the nose of the tool pointed away from you, depress the latch located at the rear of the magazine and slide the magazine open.

WARNING:

Keep the tool pointed away from yourself and others when loading nails. Failure to do so could result in possible serious personal injury.

- Feed a strip of brad nails into the magazine. Be sure the nail heads are pointed upward, the tips are pointed downward, and the tips rest against the bottom of the magazine.
- Push the magazine cover closed until it securely snaps into place.

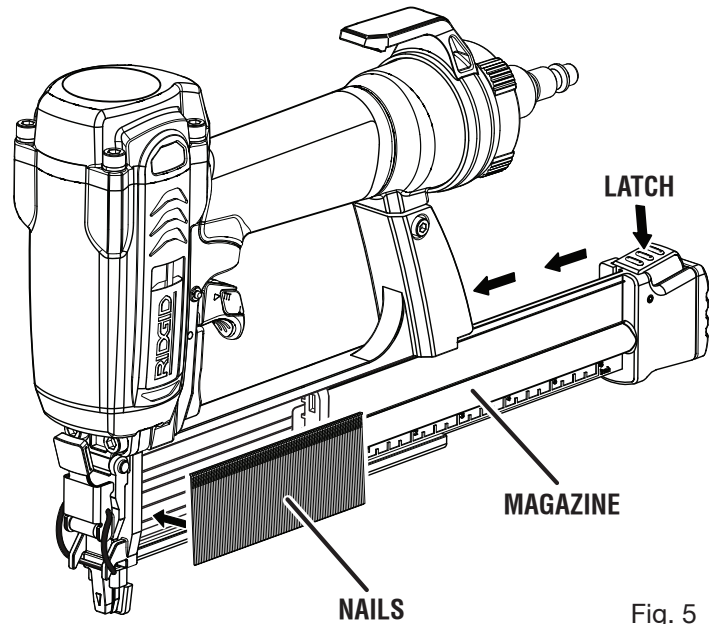

Fig. 5

WARNING:

Use only the nails recommended for use with this tool (refer to the Fastener Guide). The use of any other nails can result in tool malfunction, leading to serious injuries.

WARNING:

Never load nails with the workpiece contact or trigger activated. Doing so could result in possible serious personal injury.

OPERATION

USING THE SELECTABLE TRIGGER

See Figures 6 - 7.

WARNING:

Never wedge or hold back the workpiece contact mechanism during operation of the tool. Doing so could result in possible serious injury.

This tool is shipped from the factory with a selectable trigger set in the **Single Sequential Actuation** mode. The selectable trigger can also be set for **Contact Actuation** mode.

SINGLE SEQUENTIAL ACTUATION MODE

Single sequential actuation provides the most accurate fastener placement.

- Disconnect the tool from the air supply.
- Depress the trigger lever pivot pin.
- Rotate the selector to Position A.
- Release the trigger lever pivot pin.

WARNING:

The nailer will not function properly if the selector is not securely seated in either position A or B. Always assure the selector is seated properly to avoid an unexpected fastener discharge and possible serious personal injury.

- Reconnect the tool to the air supply.
- Grip the tool firmly to maintain control. Position the nose of the tool onto the work surface.
- Push the tool against the work surface to depress the workpiece contact.
- Pull the trigger to drive a fastener.
- Allow the tool to recoil away from the work surface as the fastener is driven.

CONTACT ACTUATION MODE

Contact actuation allows very fast repetitive fastener placement.

- Disconnect the tool from the air supply.
- Depress the trigger lever pivot pin.
- Rotate the selector to Position B.
- Release the trigger lever pivot pin.

NOTE: The trigger lever pivot pin is spring loaded and held in position by locking tab to prevent movement during operation.

- Reconnect the tool to the air supply.
- Grip the tool firmly to maintain control.
- Pull and hold the trigger. Push the tool against the work surface to depress the workpiece contact and drive a fastener.
- Allow the tool to recoil away from the work surface as the fastener is driven.

NOTE: In Contact Actuation mode, the tool may also be operated by depressing the workpiece contact against the surface and squeezing the trigger.

TRIGGER LEVER PIVOT PIN
(DEPRESS TO ALLOW
SELECTOR TO ROTATE)

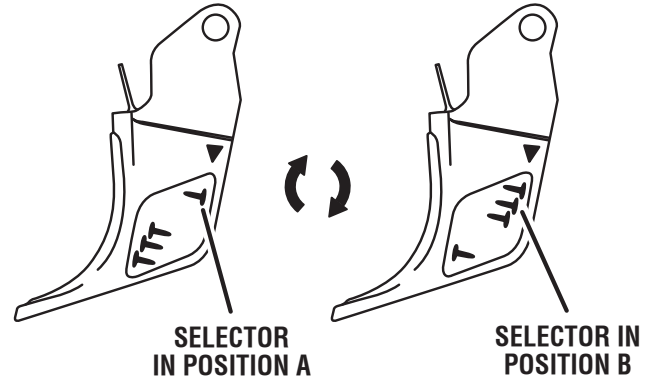
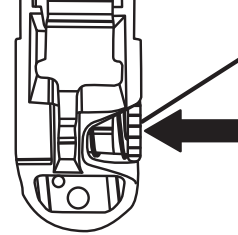

Fig. 6

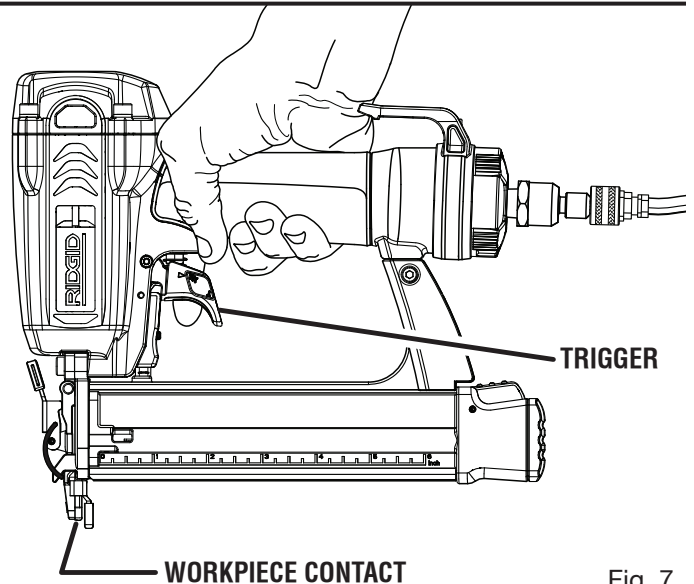

Fig. 7

WARNING:

During normal use the tool will recoil immediately after driving a fastener. This is a normal function of the tool. Do not attempt to prevent the recoil by holding the nailer against the work. Restriction to the recoil can result in a second fastener being driven from the nailer. Grip the handle firmly, let the tool do the work, and do not place second hand on top of tool or near exhaust at any time. Failure to heed this warning can result in serious personal injury.

OPERATION

SETTING THE AIR PRESSURE

The amount of air pressure required will depend on the size of the nail and the workpiece material.

Begin testing the depth of drive by driving a test nail into the same type of workpiece material used for the actual job.

Drive a test nail with the air pressure set at 90-95 psi. Raise or lower the air pressure to find the lowest setting that will perform the job with consistent results.

It may be possible to achieve the desired depth with air pressure adjustments alone. If finer adjustments are needed, use the drive depth adjustment on the tool.

DRIVE DEPTH ADJUSTMENT

See Figure 8.

The driving depth of the nail may be adjusted. It is advisable to test the depth on a scrap workpiece to determine the required depth for the application.

To determine depth of drive, first adjust the air pressure and drive a test nail. To achieve the desired depth, use the drive depth adjustment on the tool.

- Disconnect the tool from the air supply.
- Remove fasteners from the tool.
- Turn the depth selector left or right to change the driving depth.
- Reconnect the tool to the air supply.
- Load the tool with fasteners.
- Drive a test nail after each adjustment until the desired depth is set.

REMOVING NAILS FROM THE TOOL

See Figure 9.

- Disconnect the tool from the air supply.

WARNING:

Disconnect the tool from the air supply before removing nails. Failure to do so could result in serious personal injury.

- To remove a strip of nails from the tool, depress the latch located at the rear of the magazine and slide the magazine open.
- Remove the nail strip.

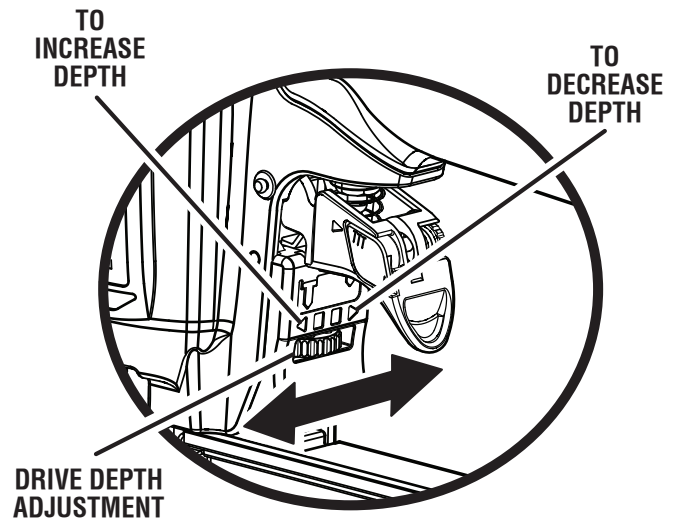

Fig. 8

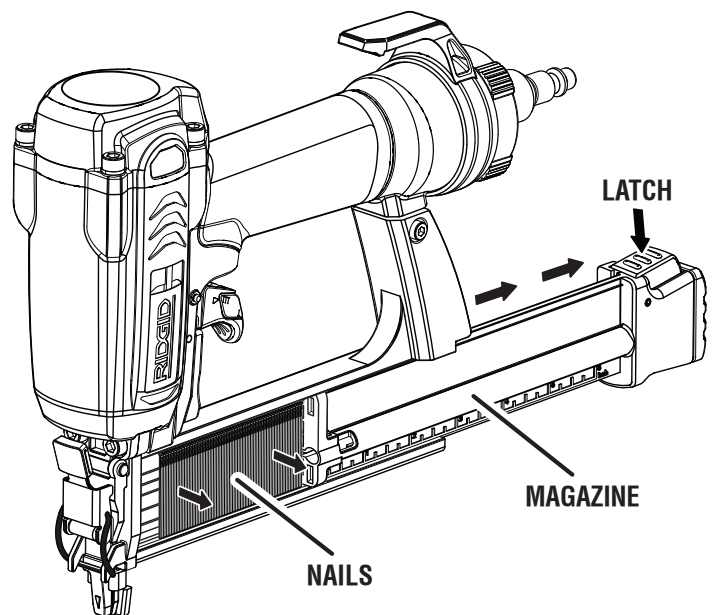

Fig. 9

OPERATION

CLEARING A JAMMED FASTENER

See Figure 10.

⚠ WARNING:

Disconnect the tool from the air supply before clearing a jammed fastener. Failure to do so could result in serious personal injury.

If a nail or fastener becomes jammed in the tool, disconnect the air hose and keep the tool pointed away from you while clearing the jam.

- Open magazine and remove fasteners from the tool.
- Pull up on the latch and open the jam release.
- Insert a flat blade screwdriver into the driving mechanism and push the driver mechanism back, freeing the fastener jam.
- Remove the bent fastener.
- Close the jam release and latch.
- Reconnect the tool to the air supply.
- Reinstall fasteners and close the magazine.

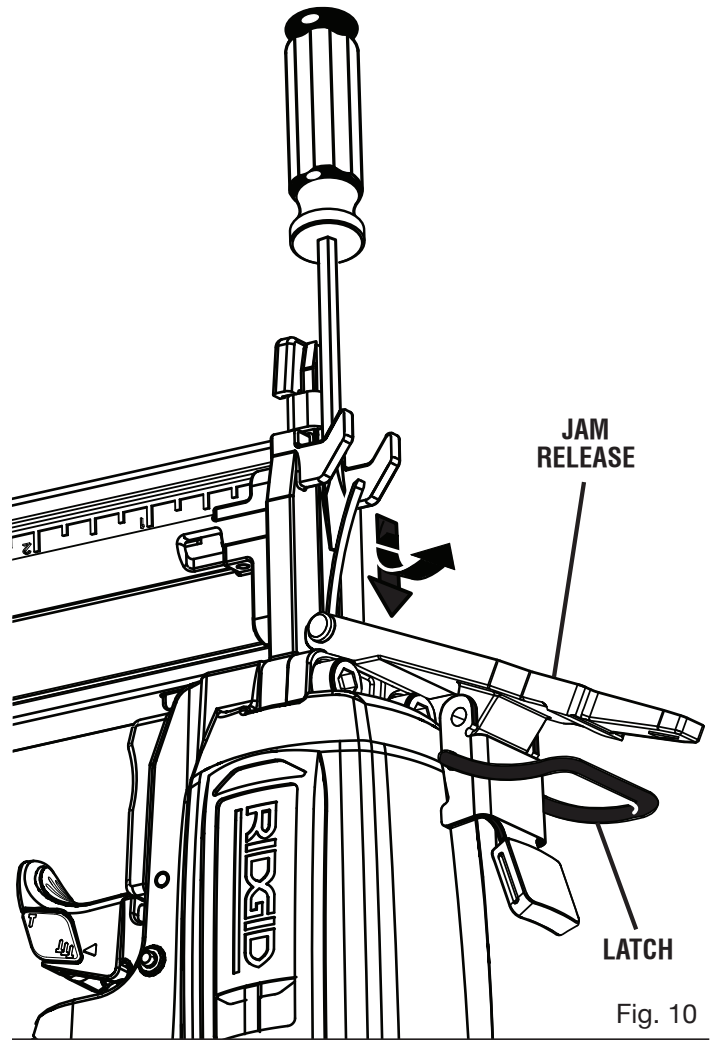

Fig. 10

MAINTENANCE



WARNING:

When servicing use only identical RIDGID® replacement parts. Use of any other parts may create a hazard or cause product damage.



WARNING:

Always wear safety goggles or safety glasses with side shields during power tool operation or when blowing dust. If operation is dusty, also wear a dust mask.



WARNING:

Disconnect the tool from the air supply before performing maintenance. Failure to do so could result in serious personal injury.

GENERAL MAINTENANCE

Avoid using solvents when cleaning plastic parts. Most plastics are susceptible to damage from various types of commercial solvents and may be damaged by their use. Use clean cloths to remove dirt, dust, oil, grease, etc.



WARNING:

Do not at any time let brake fluids, gasoline, petroleum-based products, penetrating oils, etc., come in contact with plastic parts. Chemicals can damage, weaken or destroy plastic which may result in serious personal injury.

COLD WEATHER OPERATION

For cold weather operation, near and below freezing, the moisture in the air line may freeze and prevent tool operation. We recommend the use of air tool lubricant or permanent antifreeze (ethylene glycol) as a cold weather lubricant.

CAUTION:

Do not store tools in a cold weather environment to prevent frost or ice formation on the tools' operating valves and mechanisms that could cause tool failure.

NOTE: Some commercial air line drying liquids are harmful to "O" rings and seals. Do not use these low temperature air dryers without checking compatibility.

AIR SUPPLY PRESSURE AND VOLUME

Air volume is as important as air pressure. The air volume supplied to the tool may be inadequate because of under-size fittings and hoses, or from the effects of dirt and water in the system. Restricted air flow will prevent the tool from receiving an adequate volume of air, even though the pressure reading is high. The results will be a slow operation, misfeeds or reduced driving power. Before evaluating tool problems for these symptoms, trace the air supply from the tool to the supply source for restrictive connectors, low points containing water and anything else that would prevent full volume flow of air to the tool.

MAINTENANCE

REQUIRED DAILY CHECKLIST

See Figures 11 - 12.

- Disconnect the air supply from the tool and remove all fasteners.
- Check all screws, nuts, bolts, and pins on the tool. If any of these are loose, they must be tightened with the appropriate size wrench.
- Press the workpiece contact against a workpiece to ensure that it moves smoothly.
- With the workpiece contact depressed, pull the trigger. The trigger should move smoothly, without binding.
- While the tool is not loaded, connect the appropriate air supply (at 70 psi) to the tool.
- Rotate the selectable trigger knob on the trigger to Single Sequential Actuation operation, Position A, as shown in figure 11. No air should leak from the tool.
 - Without pulling the trigger, press the workpiece contact against a workpiece several times. The tool must not operate.
 - With the workpiece contact not engaged on the workpiece, point the tool down and away and pull the trigger several times. Hold the trigger in this position for a minimum of 5 seconds. The tool must not operate.
 - Press the workpiece contact firmly against the workpiece. Pull the trigger. The tool must operate.
 - With the workpiece contact still depressed, release the trigger. The driver must return to its up position.
- Rotate the selectable trigger knob on the trigger to Contact Actuation operation, Position B, as shown in figure 12.
 - With the workpiece contact not engaged on the workpiece, point the tool down and away. Pull the trigger. The tool must not operate.
 - Keeping the trigger fully depressed, push the workpiece contact against a workpiece. The tool must operate.
- If the tool successfully meets all the requirements in this checklist, it is ready for use. Set the trigger on the tool to operate in the manner that best fits your application. Load the proper fasteners for the desired application.
- Set the depth of drive according to the **Drive Depth Adjustment** section in this manual. Repeat this checklist before using the tool each day, or if the tool is dropped or damaged in any way.

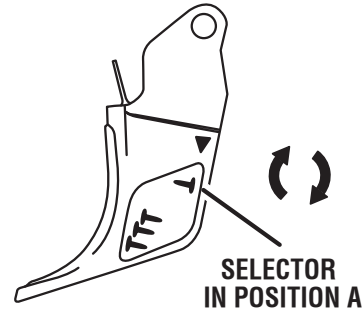

Fig. 11

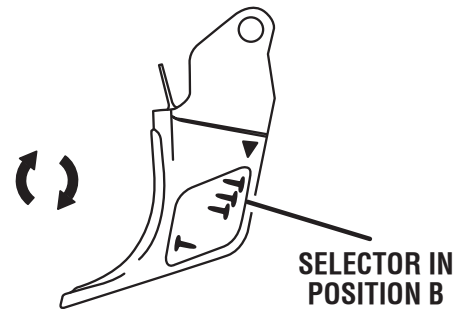

Fig. 12

ACCESSORIES

To order parts and maintenance kits, call 1-866-539-1710.

Overhaul Maintenance Kit079001001701
Driver Maintenance Kit079001001702
Driver Assembly Kit079001001703
Trigger Assembly Kit.....	.079001001085
Wrench Kit.....	.079001001099

 **WARNING:**

Current attachments and accessories available for use with this tool are listed above. Do not use any attachments or accessories not recommended by the manufacturer of this tool. The use of attachments or accessories not recommended can result in serious personal injury.

TROUBLESHOOTING

PROBLEM	POSSIBLE CAUSE	SOLUTION
Air leak near the top of the tool or in the trigger area	Loose screws Worn or damaged O-rings or seals	Tighten screws Install Overhaul Kit
Air leak near the bottom of the tool	Loose screws Worn or damaged O-rings or bumper	Tighten screws Install Overhaul Kit
Tool does nothing or operates sluggishly	Inadequate air supply Inadequate lubrication Worn or damaged O-rings or bumper	Verify adequate air supply Lubricate the tool Install Overhaul Kit
Tool jams frequently	Incorrect fasteners Damaged fasteners Loose magazine or nose screws Dirty magazine Worn or damaged driver	Verify that fasteners are the correct size Replace fasteners Tighten screws Clean magazine Install Driver Maintenance Kit

WARRANTY

RIDGID® PNEUMATIC TOOL 3 YEAR LIMITED SERVICE WARRANTY

Proof of purchase must be presented when requesting warranty service.

This product is manufactured by One World Technologies, Inc. The trademark is licensed from RIDGID, Inc. All warranty communications should be directed to One World Technologies, Inc., attn: RIDGID Pneumatic Tool Technical Service at (toll free) 1-866-539-1710.

90-DAY SATISFACTION GUARANTEE POLICY

During the first 90 days after the date of purchase, if you are dissatisfied with the performance of this RIDGID® Pneumatic Tool for any reason you may return the tool to the dealer from which it was purchased for a full refund or exchange. To receive a replacement tool you must present proof of purchase and return all original equipment packaged with the original product. The replacement tool will be covered by the limited warranty for the balance of the 3-YEAR service warranty period.

WHAT IS COVERED UNDER THE 3 YEAR LIMITED SERVICE WARRANTY

This warranty on RIDGID® Pneumatic Tools covers all defects in workmanship or materials and normal wear items for three years following the purchase date of the tool. Warranties for other RIDGID® products may vary.

HOW TO OBTAIN SERVICE

To obtain service for this RIDGID® tool you must return it; freight prepaid, or take it in to an authorized service center for RIDGID® branded pneumatic tools. You may obtain the location of the authorized service center nearest you by calling (toll free) 1-866-539-1710 or by logging on to the RIDGID® website at www.ridgid.com. When requesting warranty service, you must present the original dated sales receipt. The authorized service center will repair any faulty workmanship, and either repair or replace any part covered under the warranty, at our option, at no charge to you.

WHAT IS NOT COVERED

This warranty applies only to the original purchaser at retail and may not be transferred. This warranty only covers defects arising under normal usage and does not cover any malfunction, failure or defect resulting from misuse, abuse, neglect, alteration, modification or repair by other than an authorized service center for RIDGID® branded pneumatic tools. Consumable accessories provided with the tool such as, but not limited to, fasteners, oil, and safety glasses are not covered.

RIDGID, INC. AND ONE WORLD TECHNOLOGIES, INC. MAKE NO WARRANTIES, REPRESENTATIONS OR PROMISES AS TO THE QUALITY OR PERFORMANCE OF ITS PNEUMATIC TOOLS OTHER THAN THOSE SPECIFICALLY STATED IN THIS WARRANTY.

ADDITIONAL LIMITATIONS

To the extent permitted by applicable law, all implied warranties, including warranties of MERCHANTABILITY or FITNESS FOR A PARTICULAR PURPOSE, are disclaimed. Any implied warranties, including warranties of merchantability or fitness for a particular purpose, that cannot be disclaimed under state law are limited to three years from the date of purchase. One World Technologies, Inc. and RIDGID, Inc. are not responsible for direct, indirect, incidental or consequential damages. Some states do not allow limitations on how long an implied warranty lasts and/or do not allow the exclusion or limitation of incidental or consequential damages, so the above limitations may not apply to you. This warranty gives you specific legal rights, and you may also have other rights which vary from state to state.

One World Technologies, Inc.

P.O. Box 35, Hwy. 8
Pickens, SC 29671

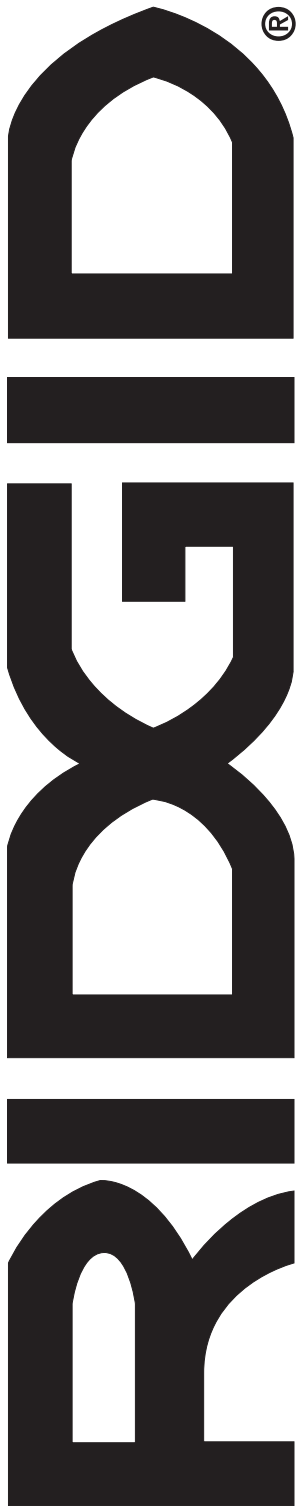

OPERATOR'S MANUAL

18 GAUGE BRAD NAILER

R138BNA

Customer Service Information:

For parts or service, contact your nearest RIDGID authorized service center. Be sure to provide all relevant information when you call or visit. For the location of the authorized service center nearest you, please call 1-866-539-1710 or visit us online at www.ridgid.com.

The model number of this tool is found on a plate attached to the magazine cover of the tool. Please record the serial number in the space provided below. When ordering repair parts, always give the following information:

Model No. _____ R138BNA _____

Serial No. _____