

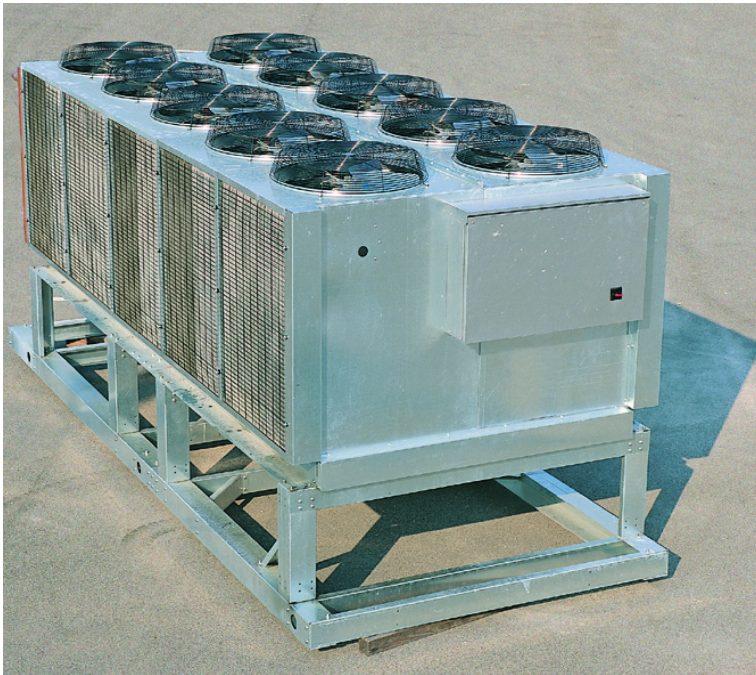

Precision Cooling  
For Business-Critical Continuity™

# Liebert® 10 Fan Drycooler/Fluid Cooler™ Including Quiet-Line Models

User Manual - 120 to 150 Tons, 50 & 60 Hz



  
**EMERSON**  
Network Power



---

# TABLE OF CONTENTS

<b>IMPORTANT SAFETY INSTRUCTIONS</b> .....	<b>INSIDE FRONT COVER</b>
<b>1.0 INTRODUCTION</b> .....	<b>3</b>
1.1 System Description and Standard Features .....	3
1.2 Optional Features .....	3
<b>2.0 PRODUCT PERFORMANCE DATA &amp; SELECTION</b> .....	<b>5</b>
2.1 Standard Data .....	5
2.2 Typical Application .....	6
2.3 Engineering Data, Calculations and Selection Procedure .....	6
2.4 Selection Example .....	9
<b>3.0 INSTALLATION</b> .....	<b>10</b>
3.1 Location Considerations .....	10
3.2 Site Preparation .....	12
3.3 Equipment Inspection Upon Delivery .....	13
3.4 Lifting and Handling the Drycooler .....	13
3.4.1 Unit Weight .....	14
3.5 Piping Connections .....	15
3.5.1 Expansion Tanks, Fluid Relief Valves and Other Devices .....	15
3.6 Filling Instructions .....	18
3.6.1 Preparing the System for Filling .....	18
3.6.2 Glycol Solutions .....	18
3.6.3 Filling the System .....	20
3.7 Electrical Connections .....	20
3.7.1 Line Voltage .....	20
3.7.2 Low Voltage Control Wiring .....	22
3.8 Checklist for Completing Installation .....	23
<b>4.0 OPERATION</b> .....	<b>24</b>
4.1 Initial Startup Procedure .....	24
4.1.1 Control Setpoints .....	24
4.1.2 Current-Sensing Relays .....	26
4.1.3 Cold Weather Operation .....	26
<b>5.0 SYSTEM MAINTENANCE</b> .....	<b>27</b>
5.1 General Procedures .....	27
5.2 Special Procedures .....	28
5.2.1 Drycooler Cleaning .....	28
5.2.2 Maintenance Inspection Checklist .....	29
<b>6.0 TROUBLESHOOTING</b> .....	<b>30</b>

---

## FIGURES

Figure 1	Typical application . . . . .	4
Figure 2	Capacity correction factor . . . . .	7
Figure 3	Pressure drop correction factor . . . . .	8
Figure 4	Clearance considerations . . . . .	11
Figure 5	Unit dimensions . . . . .	12
Figure 6	Rigging instructions . . . . .	14
Figure 7	Typical piping diagram . . . . .	16
Figure 8	Piping dimensions . . . . .	17
Figure 9	Electrical field connections . . . . .	21
Figure 10	Typical low volt wiring diagram . . . . .	22
Figure 11	Fluid temperature controls . . . . .	25
Figure 12	Current sensing relays . . . . .	26

## TABLES

Table 1	Drycooler performance data . . . . .	5
Table 2	Drycooler performance data per circuit . . . . .	5
Table 3	Drycooler performance data per circuit—metric . . . . .	5
Table 4	Maximum Liebert evaporator units per every 10 Fan Drycooler . . . . .	6
Table 5	Specific heats for aqueous ethylene glycol solutions ( $C_v$ ) . . . . .	7
Table 6	Altitude correction . . . . .	7
Table 7	Electrical specifications . . . . .	8
Table 8	Drycooler physical data . . . . .	13
Table 9	Piping, drycoolers . . . . .	17
Table 10	Piping specifications . . . . .	18
Table 11	Volume in standard Type L copper piping . . . . .	18
Table 12	Ethylene glycol concentrations . . . . .	19
Table 13	Control settings . . . . .	24

---

## IMPORTANT SAFETY INSTRUCTIONS

---

### SAVE THESE INSTRUCTIONS

This manual contains important safety instructions that should be followed during the installation and maintenance of the Liebert® 10 Fan Drycooler™. Read this manual thoroughly before attempting to install or operate this unit.

Only properly trained and qualified personnel should move, install or service this equipment.

Adhere to all warnings, cautions and installation, operating and safety instructions on the unit and in this manual. Follow all operating and user instructions.



### WARNING

Arc flash and electric shock hazard. Disconnect all electric power supplies and wear protective equipment per NFPA 70E before working within electric control enclosure. Failure to comply can cause serious injury or death.

Customer must provide earth ground to unit, per NEC, CEC and local codes, as applicable.

Before proceeding with installation, read all instructions, verify that all the parts are included and check the nameplate to be sure the voltage matches available utility power.

The line side of the disconnect switch on the front of the unit contains live high-voltage.

The only way to ensure that there is NO voltage inside the unit is to install and open a remote disconnect switch. Refer to unit electrical schematic.

Follow all local codes.



### WARNING

Risk of high-speed moving parts. Can cause injury or death.

Disconnect all local and remote electric power supplies before working in the unit.

Do not operate this unit with any or all cabinet panels and/or blower guards removed.



### CAUTION

Risk of contact with hot surfaces. Can cause injury.

The blower motors may become extremely hot during unit operation. Allow sufficient time for them to cool before working within the unit cabinet. Use extreme caution and wear protective gloves and arm protection when working on or near hot blower motors.



### CAUTION

Risk of sharp edges, splinters and exposed fasteners. Can cause injury.

Only properly trained and qualified personnel wearing appropriate safety headgear, gloves, shoes and glasses should attempt to move the unit, lift it, remove packaging or prepare the unit for installation.

### NOTICE

Risk of clogged or leaking coolant fluid lines. Can cause equipment and building damage.

Improper installation, application and service practices can result in coolant fluid leakage from the unit that can result in severe property damage.

Emerson Network Power® recommends installing leak detection equipment for unit and supply lines.

---

## **NOTICE**

Risk of a leaking coil due to freezing and/or corrosion. Can cause equipment and building damage.

Cooling coils and piping systems that are connected to open cooling towers or other open water/glycol systems are at high risk for freezing and premature corrosion. Fluids in these systems must contain the proper antifreeze and inhibitors to prevent freezing and premature coil corrosion. The water or water/glycol solution must be analyzed by a competent water treatment specialist before startup to establish the inhibitor requirement. The water or water/glycol solution must be analyzed every six months to determine the pattern of inhibitor depletion. The complexity of water-caused problems and their correction makes it important to obtain the advice of a water treatment specialist and follow a regularly scheduled maintenance program.

## **NOTICE**

Risk of damage from forklift. Can cause unit damage.

Keep tines of the forklift level and at a height suitable to fit below the skid and/or unit to prevent exterior and/or underside damage.

## **NOTICE**

Risk of improper storage. Can cause unit damage.

Keep the Liebert 10-Fan Drycooler upright and protected from freezing temperatures and contact damage.

---

## 1.0 INTRODUCTION

---

### 1.1 System Description and Standard Features

The Liebert® 10 Fan Drycooler/Fluid Cooler™ is designed for maximum heat rejection with minimum footprint and to be used with glycol solutions for large-site installations. It has a nominal range of 150 tons of heat rejection and is ideal for rejecting the heat of multiple evaporator units. Standard features include:

- Three different coil circuits: 068 (half), 136 (full), 272 (double). Each coil circuit is designed for a range of specific flow rates based on the particular application.
- Coil constructed of copper tubes in a staggered pattern expanded into continuous corrugated aluminum fins. The fins have full depth fin collars completely covering the copper tubes which are connected to heavy-wall type L headers. Inlet coil connector tubes pass through relieved holes in the tube sheet for maximum resistance to piping strain and vibration. Coil maximum operating pressure is 150 PSIG (1035 kPa).
- Wire guards constructed of coated wire, in 1" x 4" pattern, mounted to protect the exposed vertical coil surface.
- Current sensing relays are provided with customer connection to monitor change in motor current to detect possible motor/fan failure.
- Choice of either 60 or 50Hz models as well as a Liebert Quiet-Line™ 60Hz; comes from the factory completely assembled and pre-wired. Units are available in 208, 230, 460 and 575V, 3-phase, 60Hz, and 380/415V, 3-phase, 50Hz.
- Locking disconnect switch and fan cycling control.
- Unit frame of heavy galvanized steel for strength and corrosion resistance, divided internally into individual fan sections by full-width baffles to prevent fan reverse windmilling when not energized.

### 1.2 Optional Features

#### Quiet-Line

The Liebert Quiet-Line 10 Fan Drycooler includes the same features as the standard Liebert 10 Fan Drycooler, except that it has 8-pole motors in lieu of 6-pole motors for lower sound levels as well as reduced airflow and capacity. This option is not available on 50Hz units.

#### Aluminum Grilles

Aluminum grilles are used for unit aesthetic and general mechanical security purposes. The aluminum grilles extend from the base of the unit and protect the exposed coil sides.

#### Coil Fin Options

**Pre-Coated Fin Stock** provides pre-coated coil fins for added protection in corrosive environments.

**Phenolic Coated Coil** provides a baked phenolic coated coil for added protection in corrosive environments.

**Copper Fin/Copper Tube Coil** provides coil constructed of copper fins and copper tubes.

#### Enclosed Motor Option

TEAO motors are totally enclosed and are used in industrial applications. They are not available for Liebert Quiet-Line, or 575V models.

#### Ancillary Items

Tanks for fluid expansion, pumps, pump control panels, flow switches, shut off valves and relief valves should also be considered for the site/installation. Since these items are custom-sized per application, please consult with your sales representative for selection.

Figure 1 Typical application

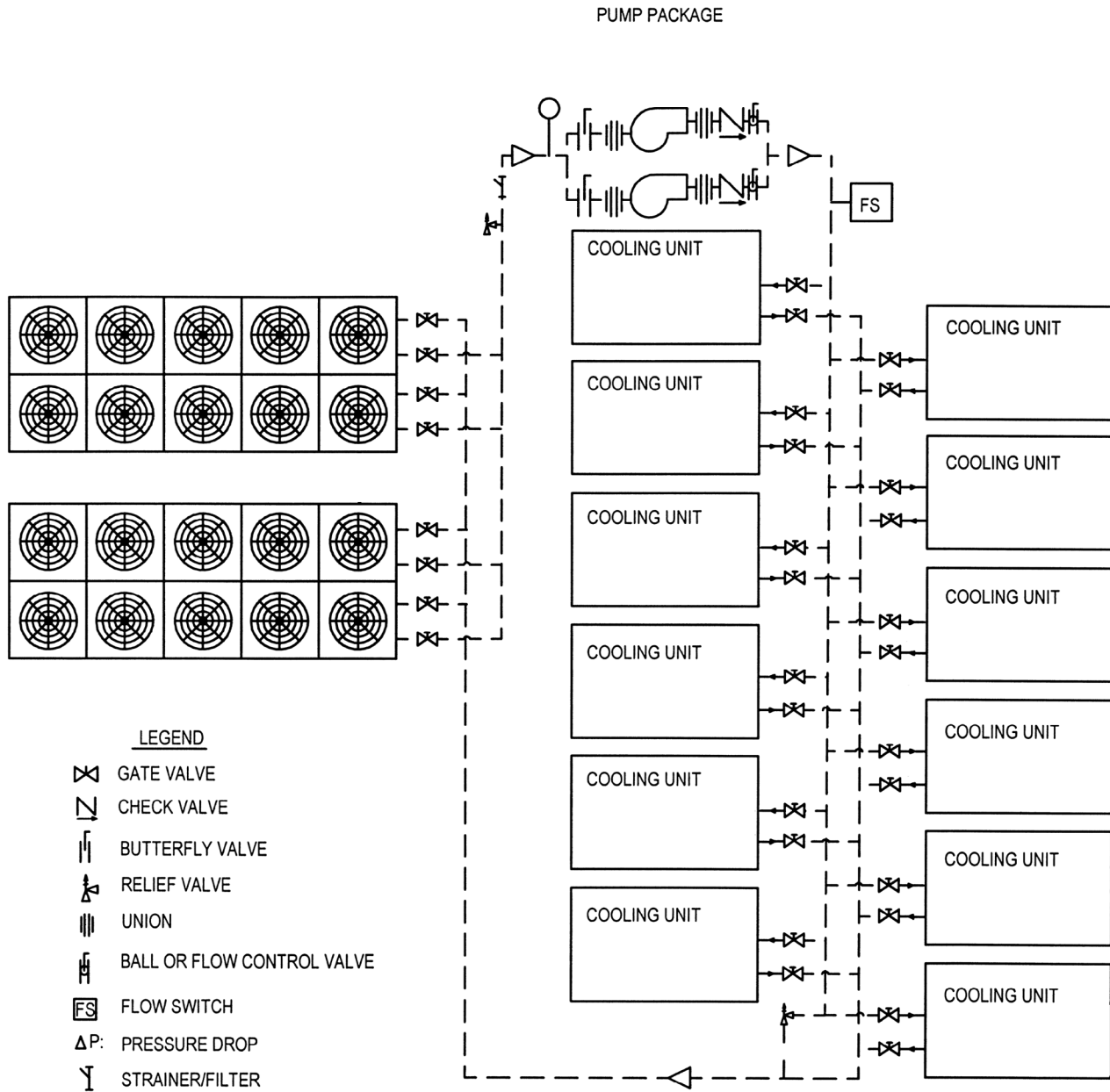

Refer to **Figure 7** for a detailed installation diagram.



## 2.0 PRODUCT PERFORMANCE DATA & SELECTION

### 2.1 Standard Data

**Table 1 Drycooler performance data**

Model No.	Hz	Total Heat Rejection* @25°F (13.9°C) ITD		Flow Rate		Pressure Drop		No. of Internal Circuits	No. & Size of Connections (inlet)	No. & Size of Connections (outlet)	No. of Fans	Air Flow		Sound	Internal Volume		Shipping Weight	
		Btu/h	kW	gpm	lps	Ft of Water	kPa					cfm	cmh		dBA**	Gal	L	Lbs
120	60	1,172,000	343	136	8.6	27.2	81.2	68	2@2.625	2@2.625	10	74160	126000	65	92.8	351	5100	2313
		1,447,000	424	272	17.2	15.8	47.1	136	2@4.125	2@4.125	10	74160	126000	65	92.8	351	5100	2313
		1,579,000	463	544	34.3	15.1	45.1	272	2@4.125	2@4.125	10	74160	126000	65	92.8	351	5100	2313
150	60	1,287,000	377	136	8.6	27.3	81.5	68	2@2.625	2@2.625	10	99030	168250	72	92.8	351	5100	2313
		1,703,000	499	272	17.2	15.8	47.1	136	2@4.125	2@4.125	10	99030	168250	72	92.8	351	5100	2313
		1,924,000	564	544	34.3	15.1	45.1	272	2@4.125	2@4.125	10	99030	168250	72	92.8	351	5100	2313
150	50	1,218,000	357	136	8.6	27.3	81.5	68	2@2.625	2@2.625	10	82450	140080	68	92.8	351	5100	2313
		1,541,000	452	272	17.2	15.8	47.1	136	2@4.125	2@4.125	10	82450	140080	68	92.8	351	5100	2313
		1,703,000	499	544	34.3	15.1	45.1	272	2@4.125	2@4.125	10	82450	140080	68	92.8	351	5100	2313

\* Ratings based on using 40% ethylene glycol @ 95°F (35°C) entering air, 120°F (48.9°C) entering glycol; 2 gpm (.13 l/s) circ.

\*\* Sound data is for sound pressure measured @ 5 ft. (1.5m) height, 30 ft.(9.1 m) from the unit.

**Table 2 Drycooler performance data per circuit**

Model No.	Hz	No. of Internal Circuits	Flow Rate Range min-max gpm	Heat Rejection per ITD* (Btu/h/°F)			Pressure Drop* (ft of water)		
				Flow Rate per Circuit (gpm/circuit)			Flow Rate per Circuit (gpm/circuit)		
				1	1.5	2	1	1.5	2
120	60	68	68-136	29,507	39,991	46,972	8.2	16.1	27.3
		136	136-340	45,829	53,713	57,917	5	9.2	23.7
		272	272-544	56,201	60,785	63,153	4	8.7	15.1
150	60	68	68-136	30,144	42,440	51,621	8.2	16.1	27.3
		136	136-340	50,346	61,660	68,219	5	9.2	23.7
		272	272-544	65,785	73,118	77,019	4	8.7	15.1
150	50	68	68-136	29,791	41,011	48,823	8.2	16.1	27.3
		136	136-340	47,617	56,724	61,728	5	9.2	23.7
		272	272-544	59,756	65,257	68,146	4	8.7	15.1

\* Data is based on 40% ethylene glycol solution at 115°F (46.1°C) average solution temperature expressed in Btu/h.

**Table 3 Drycooler performance data per circuit—metric**

Model No.	Hz	No. of Internal Circuits	Flow Rate Range min-max lps	Heat Rejection per ITD* (kW/°C)			Pressure Drop* (kPa)		
				Flow Rate per Circuit (lps/circuit)			Flow Rate per Circuit (lps/circuit)		
				0.06	0.09	0.13	0.06	0.09	0.13
120	60	68	6-13	23.9	29.8	32.1	24.5	48.0	81.5
		136	13-26	30.8	31.9	32.0	14.9	27.5	70.7
		272	26-38	30.7	30.6	30.5	11.9	26.0	45.1
150	60	68	6-13	24.9	33.1	37.5	24.5	48.0	81.5
		136	13-26	36.0	39.1	39.8	14.9	27.5	70.7
		272	26-38	37.9	38.4	39.0	11.9	26.0	45.1
150	50	68	6-13	24.4	31.1	34.2	24.5	48.0	81.5
		136	13-26	32.8	34.6	34.7	14.9	27.5	70.7
		272	26-38	33.3	33.4	33.3	11.9	26.0	45.1

\* Data is based on 40% ethylene glycol solution at 46.1°C (115°F) average solution temperature expressed in kW.

## 2.2 Typical Application

The most popular use for the Liebert® 10 Fan Drycooler™ is at sites with large cooling loads, such as data center/telecom sites where multiple indoor air conditioners are used. See **Table 4** for general outline of suggested quantity of indoor units for each Liebert 10 Fan Drycooler or contact your Emerson® representative for custom matchup. **Figure 1** illustrates typical application.

**Table 4 Maximum Liebert evaporator units per every 10 Fan Drycooler**

Liebert Deluxe Model 60 Hz (50 Hz)	Liebert Deluxe Unit Capacity	Maximum Deluxe Units/10 Fan Drycooler	Outdoor Ambient Rating	Total System		Drycooler <sup>1</sup> Model #
				gpm	(lps)	
110 G (111 G)	8 tons (28.1 kW)	12	95°F (35°C)	384	(24.2)	D*N*150**272
		9	100°F (37.8°C)	288	(18.2)	D*N*150**136
		6	105°F (40.6°C)	192	(12.1)	
116 G (121 G)	10 tons (35.2 kW)	10	95°F (35°C)	380	(24.0)	D*N*150**272
		7	100°F (37.8°C)	266	(16.8)	D*N*150**136
		5	105°F (40.6°C)	190	(12.0)	
192 G	15 tons (52.7 kW)	7	95°F (35°C)	378	(23.8)	D*N*150**272
		5	100°F (37.8°C)	270	(17.0)	D*N*150**136
		4	105°F (40.6°C)	216	(13.6)	
240 G	20 tons (70.3 kW)	6	95°F (35°C)	402	(25.4)	D*N*150**272
		4	100°F (37.8°C)	268	(16.9)	D*N*150**136
		3	105°F (40.6°C)	201	(12.7)	
363 G	30 tons (105 kW)	4	95°F (35°C)	312	(19.7)	D*N*150**272
		3	100°F (37.8°C)	234	(14.8)	D*N*150**136
		2	105°F (40.6°C)	156	(9.8)	

1. Ratings based on using 40% ethylene glycol @ listed outdoor ambient rating temperature, 120°F (48.9°C) entering glycol. Selections are valid for standard or TEAO motors. Consult your local Liebert representative for Quiet-Line selections.

## 2.3 Engineering Data, Calculations and Selection Procedure

An alternate, detailed procedure is available to calculate values and select the correct the 10 Fan Drycooler(s) for the application. This can be used to assist in selecting drycoolers for applications for ambient conditions that are not standard. Use the following steps.

- Determine the following items to begin this procedure:
  - Design outdoor ambient air temperature,  $T_{oa}$  (F or C)
  - Fluid Flow Rate,  $V_T$  (gpm or lps)
  - % ethylene glycol concentration
  - Fluid temperatures at drycooler: Entering,  $T_{ef}$  and leaving  $T_{lf}$  (F or C), or
  - Total Required Heat Rejection,  $QR_T$  (Btu/h or kW) and one of the fluid temperatures above
- Find the following values using these equations and known values above:
  - Initial Temperature Difference (ITD) of entering fluid to outdoor design air,  $ITD = T_{ef} - T_{oa}$
  - Total Required Heat Rejection,  $QR_T = V_T * c_v * (T_{ef} - T_{lf})$ , where  $c_v$  is found in **Table 5**, or
  - Leaving fluid temperature,  $T_{lf} = T_{ef} - QR_T / (V_T * c_v)$  where  $c_v$  is found in **Table 5**.
- Find the Average Fluid Temperature,  $T_{f,avg} = (T_{ef} + T_{lf}) / 2$
- Find Required Heat Rejection per ITD,  $QR_{ITD} = QR_T / (ITD * f)$ , where  $f$  is the capacity correction factor found in **Figure 2**.
- Using **Table 2** columns titled Flow Rate Range and Heat Rejection per ITD, choose the Drycooler Model matching application fluid flow rate and meeting/exceeding the required Heat Rejection per ITD,  $QR_{ITD}$  from Step 4.

6. Find the Flow Rate per Circuit,  $V_C = V_T / \text{circuits}$  for the drycooler selected in **Table 2**. This should be in the range of 1.0 to 2.0 gpm/circuit (0.06 to 0.13 lps/circuit) for proper long-term performance.
7. In **Table 2**, for the selected Model Number, find the Actual Heat Rejection per ITD using the gpm/circuit from Step 6. You may interpolate between columns as required. The Actual Heat Rejection should be equal to or greater than per ITD,  $QR_{ITD}$  (higher altitude application sites should use **Table 6** correction factors to reduce Actual Heat Rejection results). If it is less, repeat process from Step 5 using a larger model. If 10 Fan Drycooler solution is oversized, lower capacity drycoolers are available and may be considered as an alternative solution.
8. Calculate the Total Actual Heat Rejection,  $QA$ , for the drycooler, using the Actual Heat Rejection per ITD (Step 7) and actual ITD and correcting for % glycol and AFT (see **Figure 2**).  

$$QA = QA_{ITD} * ITD * f$$
9. After selecting a model, look up the unit's Pressure Drop in **Table 2**. Multiply this pressure drop by the correction factor found in **Figure 3**. If the resulting pressure drop is higher than your system design, go back to Step 5 and select a model with more circuits or consider multiple units. Contact your sales representative for additional design assistance.
10. Electrical data for model selected is found in **Table 7**.

**Table 5 Specific heats for aqueous ethylene glycol solutions ( $C_p$ )**

% Ethylene Glycol	0%	10%	20%	30%	40%	50%
Btu/h/gpm°F	500	490	480	470	450	433
kW/lps°C	4.18	4.09	4.01	3.93	3.76	3.62

**Table 6 Altitude correction**

Altitude - Feet (M)	0 (0)	1000 (305)	2000 (610)	5000 (1525)	8000 (2440)	12000 (3660)	15000 (4575)
Correction Factor	1.000	0.979	0.960	0.900	0.841	0.762	0.703

**Figure 2 Capacity correction factor**

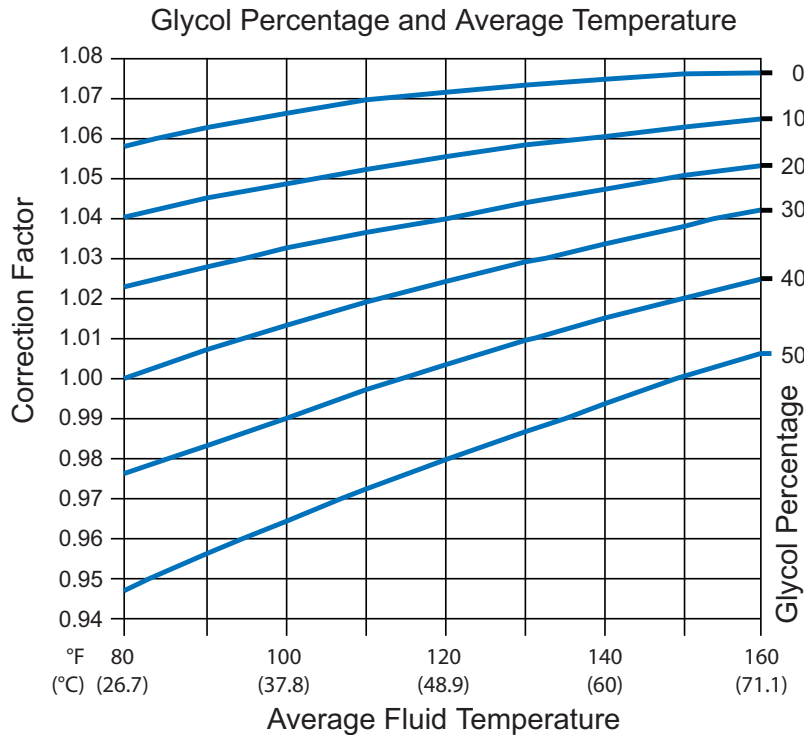

Figure 3 Pressure drop correction factor

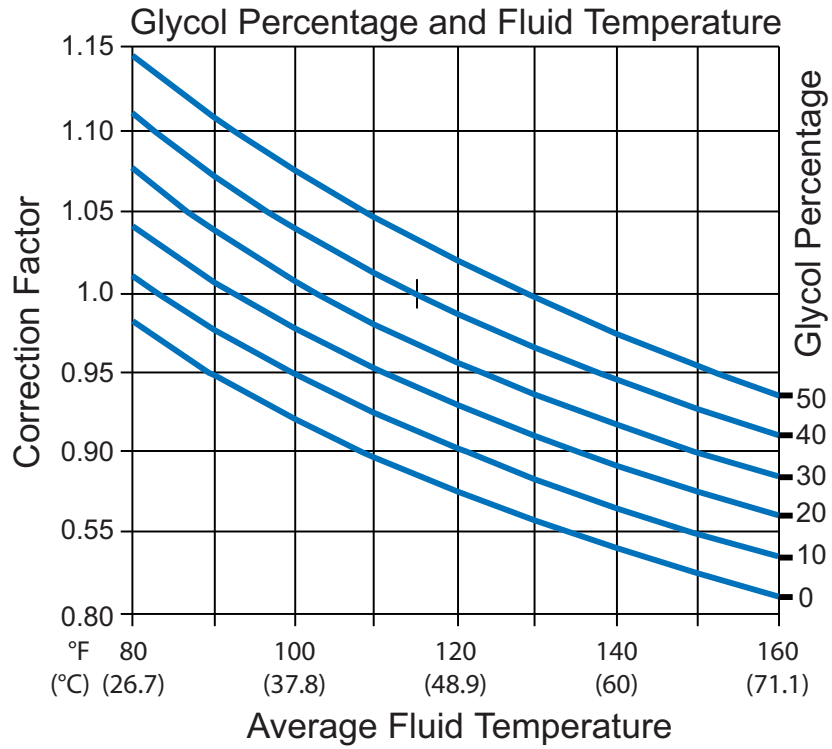

Table 7 Electrical specifications

Drycooler Model	Voltage-Phase	60 Hz												50 Hz		
		208-3			230-3			460-3			575-3			380/415-3		
		FLA	MCA	OPD	FLA	MCA	OPD	FLA	MCA	OPD	FLA	MCA	OPD	FLA	MCA	OPD
D0N*150	STANDARD	70	72	90	70	72	90	35	36	45	28	30	35	35	36	40
DTN*150	TEAO	70	72	90	70	72	90	35	36	45	n/a	n/a	n/a	n/a	32	35
DGN*120	QuietLine	48	50	60	48	50	60	24	25	30	28	30	35	24	25	30

## 2.4 Selection Example

For the following example, English (I-P) units will be used. Metric units are also provided in the tables and figures.

Find a drycooler to cool 340 gpm of 20% ethylene glycol/water solution from 125°F to 115°F. Application is near sea level and has an outdoor design air temperature of 95°F.

- Assume the following values:
  - $T_{oa} = 95^{\circ}\text{F}$
  - $V_T = 340 \text{ gpm}$
  - 20% ethylene glycol
  - $T_{ef} = 125^{\circ}\text{F}$
  - $T_{lf} = 115^{\circ}\text{F}$
- Initial temperature difference,  $\text{ITD} = T_{ef} - T_{oa} = 125 - 95 = 30^{\circ}\text{F}$ 
  - Since  $T_{ef}$  is known, calculate Total Required Heat Rejection,  $\text{QR}_T = V_T * c_v * (T_{ef} - T_{lf})$
  - Using **Table 5**,  $c_v = 480$  for 20% ethylene glycol.
  - $\text{QR}_T = 340 \text{ gpm} * 480 \text{ Btu/h} / \text{gpm}^{\circ}\text{F} * (125^{\circ}\text{F} - 115^{\circ}\text{F}) = 1,632,000 \text{ Btu/h}$
- Average Fluid Temperature,  $T_{f,avg} = (T_{ef} + T_{lf}) / 2 = (125^{\circ}\text{F} + 115^{\circ}\text{F}) / 2 = 120^{\circ}\text{F}$
- Required Heat Rejection per ITD,  $\text{QR}_{\text{ITD}} = \text{QR}_T / (\text{ITD} * f)$ , where  $f$  is found from **Figure 2**.
  - Using **Figure 2**,  $f = 1.04$  for 120°F and 20% EG concentration.
  - $\text{QR}_{\text{ITD}} = 1,632,000 \text{ Btu/h} / (30^{\circ}\text{F} * 1.04) = 52,300 \text{ Btu/h} / ^{\circ}\text{F}$
- Locate Model Number(s) in **Table 2**, matching flow rate of 340 gpm and meeting or exceeding 52,300 Btu/h / °F. Either Model 120 with 272 circuits or the Model 150 with 272 circuits matches the flow rate requirements and meets or exceeds the Required Heat Rejection per ITD. For this example, Model 150 will be chosen to complete the procedure.
- Flow rate per circuit,  $V_C = V_T / \text{circuits} = 340 \text{ gpm} / 272 \text{ circuits} = 1.25 \text{ gpm/circuit}$ . This is within the 1.0 to 2.0 gpm/circuit range.
- Using **Table 2**, the actual Heat Rejection per ITD,  $\text{QA}_{\text{ITD}}$  for Model 150 with 272 circuits @ 1.25 gpm/circuit is 69,526 Btu/h / °F, which exceeds our Required Heat Rejection per ITD of 52,300 Btu/h / °F. No correction for altitude is required.
- Total Actual Heat Rejection for the drycooler,  $\text{QA} = \text{QA}_{\text{ITD}} * \text{ITD} * f$ , where  $f$  is found in **Figure 2**.
  - $\text{QA} = 69,526 \text{ Btu/h} / ^{\circ}\text{F} * 30^{\circ}\text{F} * 1.04 = 2,169,211 \text{ Btu/h}$
- Pressure drop for 1.25 gpm/circuit is 6.25 ft., water using **Table 2** for 40% ethylene glycol and  $T_{f,avg} = 115^{\circ}\text{F}$ . Use **Figure 3** to find correction factor for the pressure drop for 20% ethylene glycol and  $T_{f,avg} = 120^{\circ}\text{F}$ . Therefore, the pressure drop will be  $6.259 * 0.93 = 5.8 \text{ ft., water}$ .
- Using **Table 7** and Drycooler Model DON\*150 with a 460 VAC, 3-phase, 60 Hz motor, the electrical requirements will be FLA = 31 amps, WSA = 32 amps and OPD = 35 amps.

---

## 3.0 INSTALLATION

---

**NOTE**

*Follow all unit dimensional drawings carefully. Determine whether any building alterations are required to run piping and wiring. Also refer to the submittal engineering dimensional drawings.*

### 3.1 Location Considerations

The drycooler should be located for maximum security and maintenance accessibility. Avoid ground level sites with public access or areas which contribute to heavy snow or ice accumulations. To assure an adequate air supply, it is recommended that drycoolers be located in a clean air area, away from loose dirt and foreign matter that may clog the coil. In addition, drycoolers must not be located in the vicinity of steam, hot air, or fume exhausts.

The unit may be mounted either at ground level or on a roof, given proper structural support and following a review of local codes. Pit installations are not recommended. Air re-circulation will severely affect unit and/or system performance. For these same reasons, units should not be installed closer than 72" (1829 mm) from a wall. This clearance should be increased to 96" (2438 mm) in corner wall situations. In multiple unit installations, units should not be installed closer than 72" (1829 mm) end to end or 96" (2438 mm) side to side. For further details, see **Figure 4**.

Figure 4 Clearance considerations

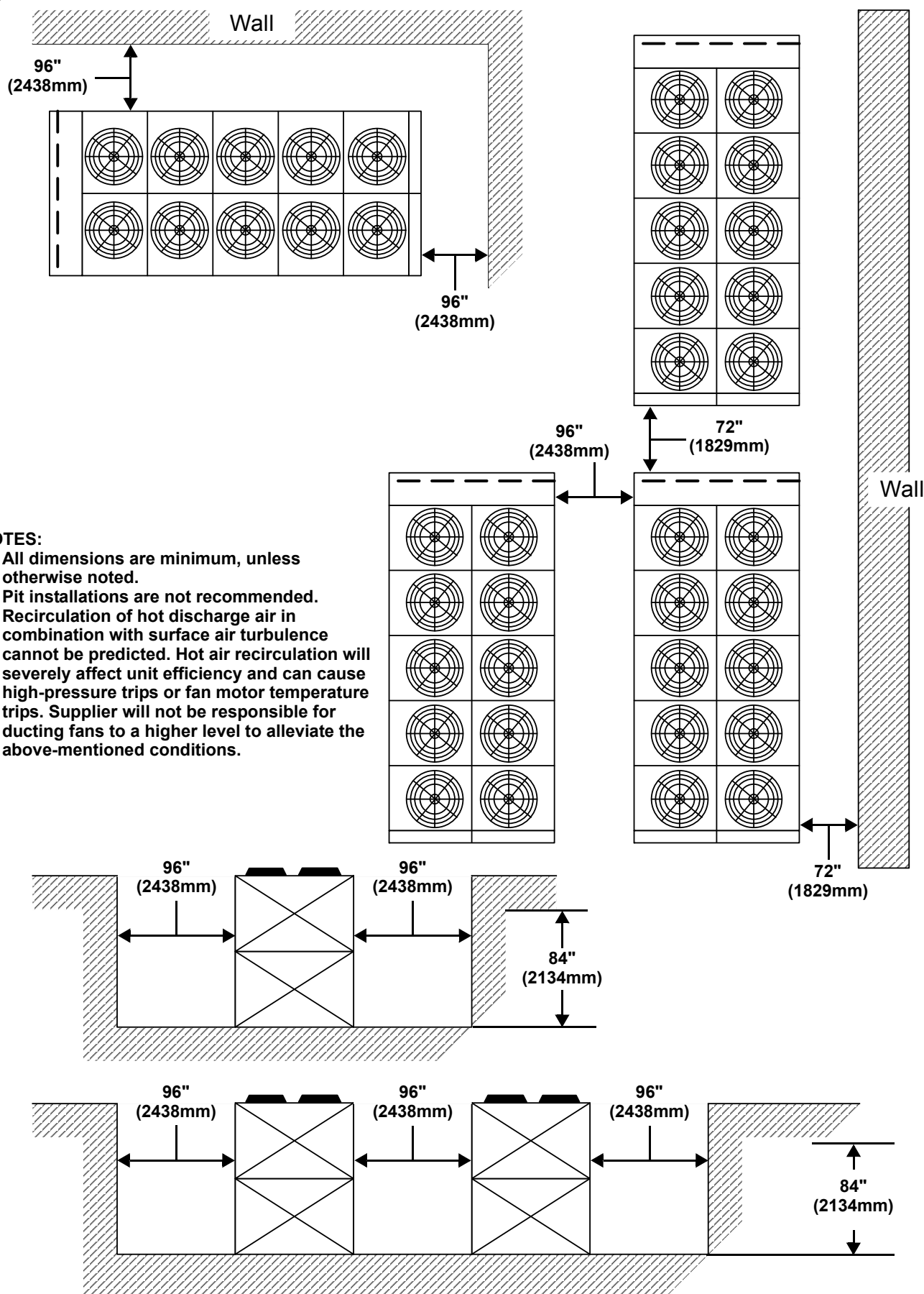

**NOTES:**

1. All dimensions are minimum, unless otherwise noted.
2. Pit installations are not recommended. Recirculation of hot discharge air in combination with surface air turbulence cannot be predicted. Hot air recirculation will severely affect unit efficiency and can cause high-pressure trips or fan motor temperature trips. Supplier will not be responsible for ducting fans to a higher level to alleviate the above-mentioned conditions.

### 3.2 Site Preparation

Drycoolers should be installed in a level position to assure proper venting and drainage. This space should have all services (electrical, drain, water) in close proximity. Also, the space should be level and free of loose gravel, sand, flooring or roofing. For roof installation, mount drycoolers on steel supports in accordance with local codes. To minimize sound and vibration transmission, mount steel supports across load-bearing walls. For ground installations, a concrete pad is sufficient to carry the load. The base should be at least 2 inches (51 mm) higher than the surrounding grade and 2 inches (51 mm) larger than the dimensions of the unit base. The drycooler base has mounting holes for securing the drycooler once installed. See **Figure 5**.

**Figure 5 Unit dimensions**

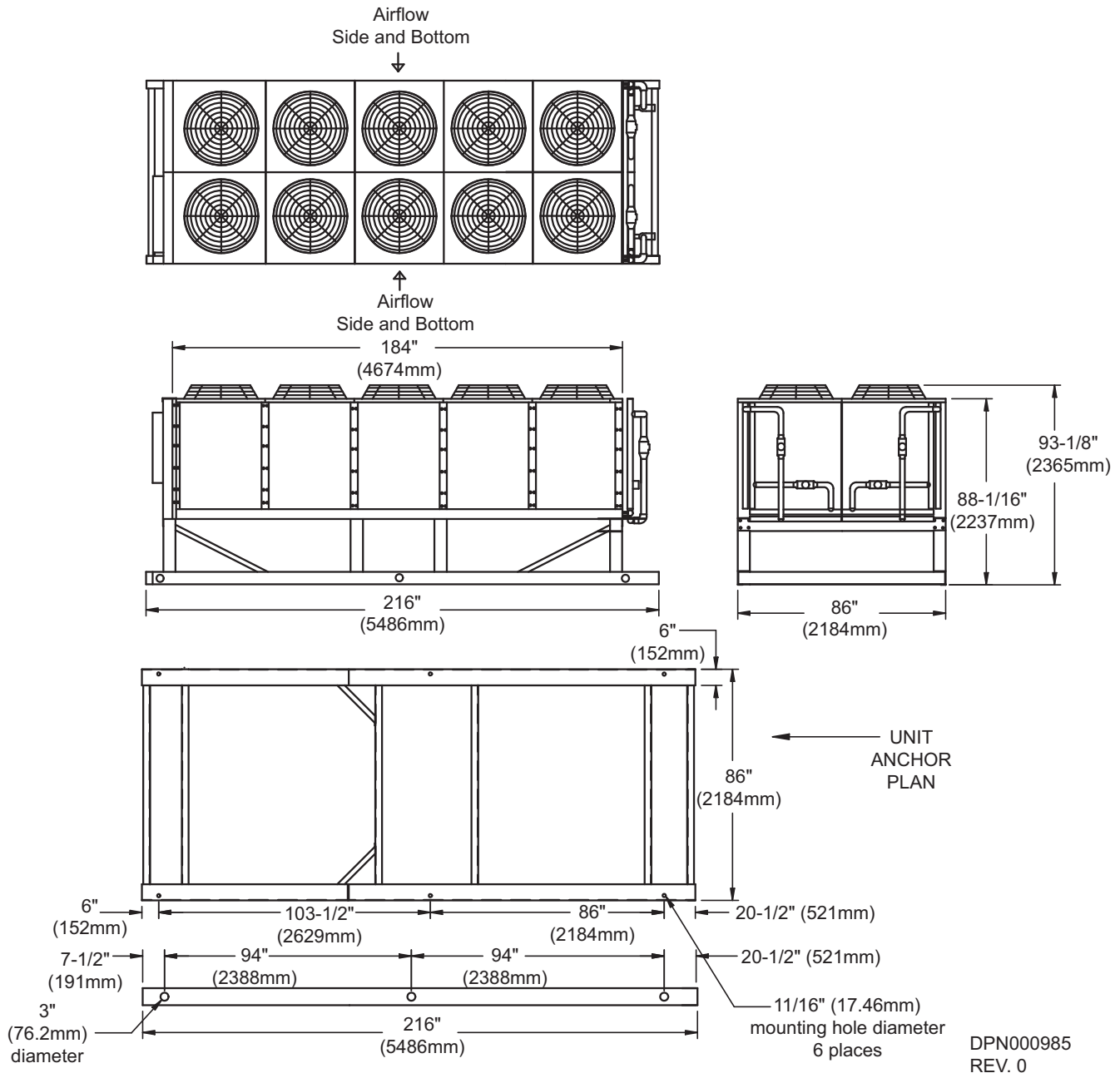



**Table 8 Drycooler physical data**

Model #	No. of Fans	CFM (CMH) 60Hz.	CFM (CMH) 50Hz.	Coil Internal Vol. Gal (L)	Net Weight Lb (kg)
D*N*150**068	10	99030 (168250)	82450 (140080)	92.8 (351)	5100 (2313)
D*N*150**136	10	99030 (168250)	82450 (140080)	92.8 (351)	5100 (2313)
D*N*150**272	10	99030 (168250)	82450 (140080)	92.8 (351)	5100 (2313)
DGN*120**068	10	74160 (126000)	N/A	92.8 (351)	5100 (2313)
DGN*120**136	10	74160 (126000)	N/A	92.8 (351)	5100 (2313)
DGN*120**272	10	74160 (126000)	N/A	92.8 (351)	5100 (2313)

### 3.3 Equipment Inspection Upon Delivery

When the Liebert® 10 Fan Drycooler™ arrives, inspect it for any visible or concealed damage. Do not accept a damaged unit from the shipper!



#### NOTE

*Any damage caused in transit must be reported immediately to the carrier and a damage claim filed with a copy sent to your sales representative. Failure to do so may result in an inability to recover costs for damage.*

Before removing the drycooler from the truck/container, review the previous section, **3.2 - Site Preparation**.

## NOTICE

Risk of exposure to freezing temperatures. Can cause equipment damage.

If the drycooler is not installed immediately upon receipt, special storage precautions should be taken. It is recommended that the unit be stored in a dry, heated place. Do not store the unit at temperatures below 36°F (2.2°C). If the storage temperature is below 36°F (2.2°C), water vapor can condense in the coil, freeze and cause permanent damage. Failure to store unit properly will void the warranty.

### 3.4 Lifting and Handling the Drycooler



## WARNING

Risk of unit very heavy unit tipping over. Can cause equipment damage, personal injury and death.

Do not unload the drycooler with a forklift. The drycooler's high center of gravity makes it a tipping hazard. Further, tilted forks may damage the drycooler. Use chains and hooks when removing the unit from the truck and when moving it between areas of equal height.

Riggers are required to lift the unit into place. Refer to **Figure 6** for lift locations. Any time the unit is lifted, use slings or chains (with spreader bars) attached to the three lifting eyes on either side of the unit base. Do not allow any part of the lifting apparatus to bear against the coil fins. All lifting apparatus must also clear the fan guards on the top of the unit.

### 3.4.1 Unit Weight

Dry weight of the unit is 5100 lb. (2313kg).



## WARNING

Risk of unit very heavy unit tipping over. Can cause equipment damage, personal injury and death.

To avoid a tilt hazard, adjustment may be necessary to locate the center of gravity before lifting the unit.

Figure 6 Rigging instructions

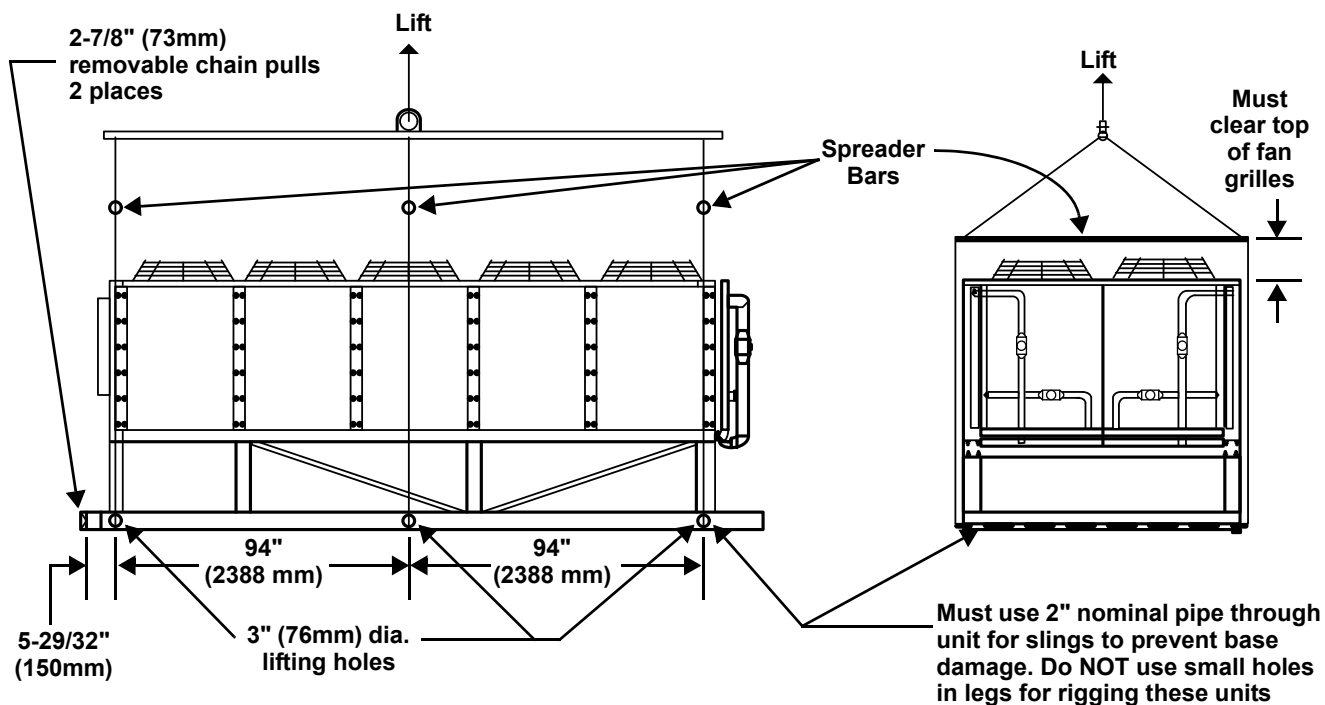

## 3.5 Piping Connections

See **Figure 7** for a typical piping diagram. See **Figure 8** piping locations.

### NOTICE

Risk of overpressurization. Can cause equipment damage.

To avoid the possibility of burst pipes, it is necessary to install a relief valve in the system. This valve may be obtained from your supplier as an option or may be sourced from another vendor. Galvanized pipe must not be used in glycol systems. To help prevent piping failures, supply and return lines must be supported such that their weight does not bear on the piping of the unit or pumps.



### NOTE

*Units are shipped pressurized with a 30 psig dry air holding charge.*

It is recommended that manual service shutoff valves be installed at the supply and return connections to each unit. This enables routine service and/or emergency isolation of the unit. In addition, multiple pump packages require a check valve at the discharge of each pump to prevent backflow through the standby pump(s).

Emerson® recommends installing filters/strainers in the supply line. These filters or strainers should be a type that can be easily replaced or cleaned, with 16-20 mesh screen. These filters extend the service life of the drycooler and the system's pumps.

Emerson recommends installing hose bibs at the lowest point of the system to facilitate filling.

Consideration of the minimum glycol temperature to be supplied from the drycooler will determine if the glycol supply and return lines must be insulated to prevent condensation on the glycol lines in low ambient conditions.

All fluid piping must comply with local codes. Care in sizing pipes will help reduce pumping power and operating costs.

### 3.5.1 Expansion Tanks, Fluid Relief Valves and Other Devices

An expansion tank must be provided for expansion and contraction of the fluid due to temperature change in this closed system. Vents are required at system high points to vent trapped air when filling the system. A relief valve is also a necessary piping component.

Depending on the complexity of the system, various other devices may be specified. Pressure gauges, flow switches, automatic air separator, tempering valves, standby pumps and sensors for electrical controls are just a few of these devices.

### NOTICE

Risk of burst pipes and leaking water from freezing temperatures. Can cause equipment and building damage.

Immediately following the use of water for leak testing or system cleaning, charge the tested system with the proper percentage of glycol and water for the coldest design ambient expected. Complete system drain-down cannot be ensured, and damage to the system could result from freezing of residual water.

Figure 7 Typical piping diagram

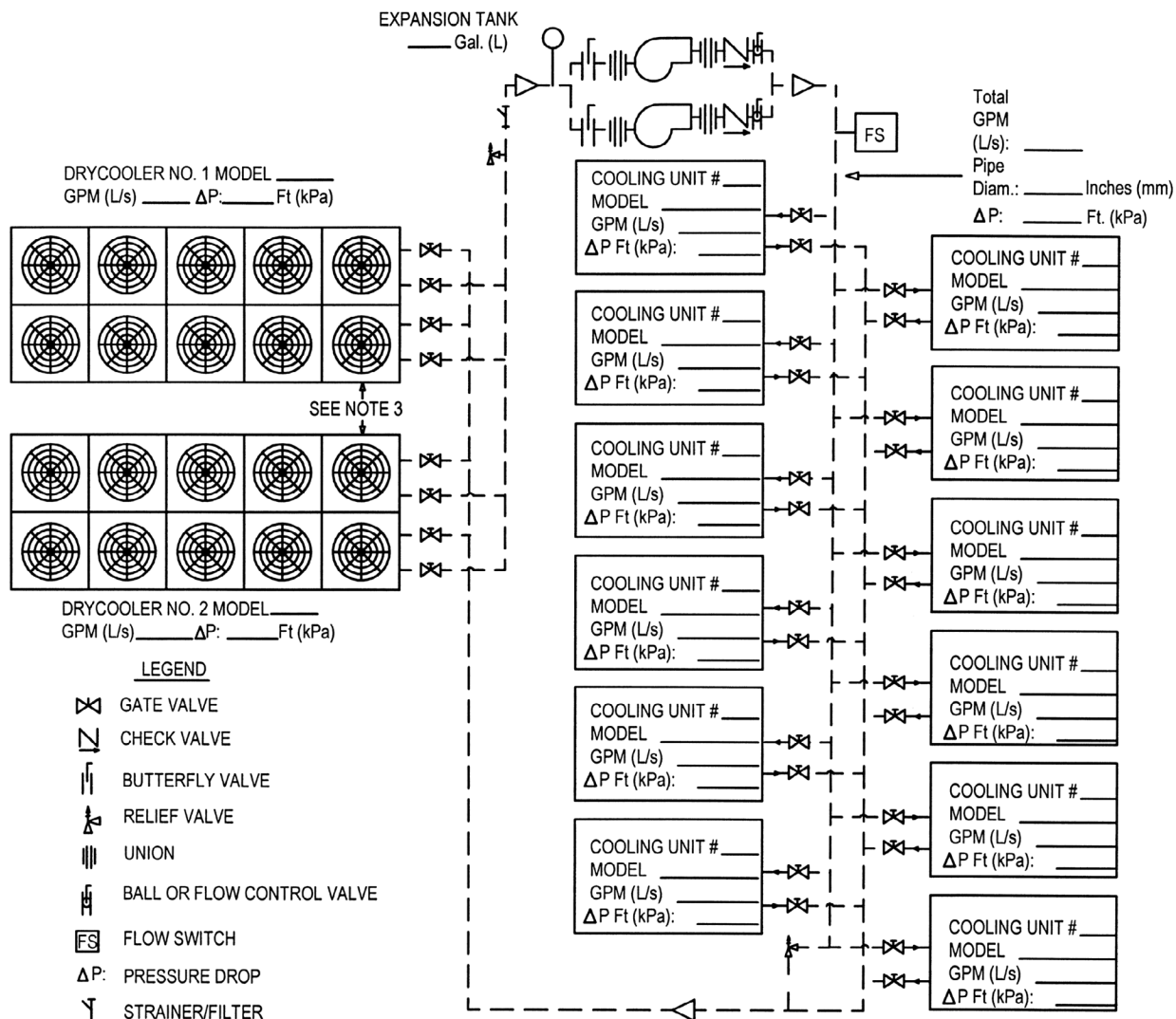

NOTES:

1. PRESSURE AND TEMPERATURE GAUGES (OR PORTS FOR SAME) ARE RECOMMENDED TO MONITOR COMPONENT PRESSURE DROPS AND PERFORMANCE.
2. FLOW MEASURING DEVICES, DRAIN AND BALANCING VALVES TO BE SUPPLIED BY OTHERS AND LOCATED AS REQUIRED.
3. SEE PRODUCT LITERATURE FOR INSTALLATION GUIDELINES AND CLEARANCE DIMENSIONS.
4. DRAWING SHOWS DUAL PUMP PACKAGE. ALTERNATE PUMP PACKAGES WITH MORE PUMPS MAY BE CONSIDERED, CONSULT SUPPLIER.

Figure 8 Piping dimensions

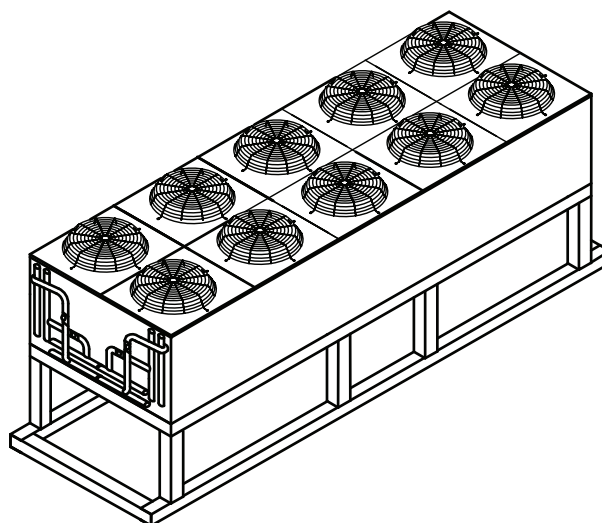

NOTE  
Tolerance of  $\pm 1"$  (25.4mm)  
on all piping dimensions

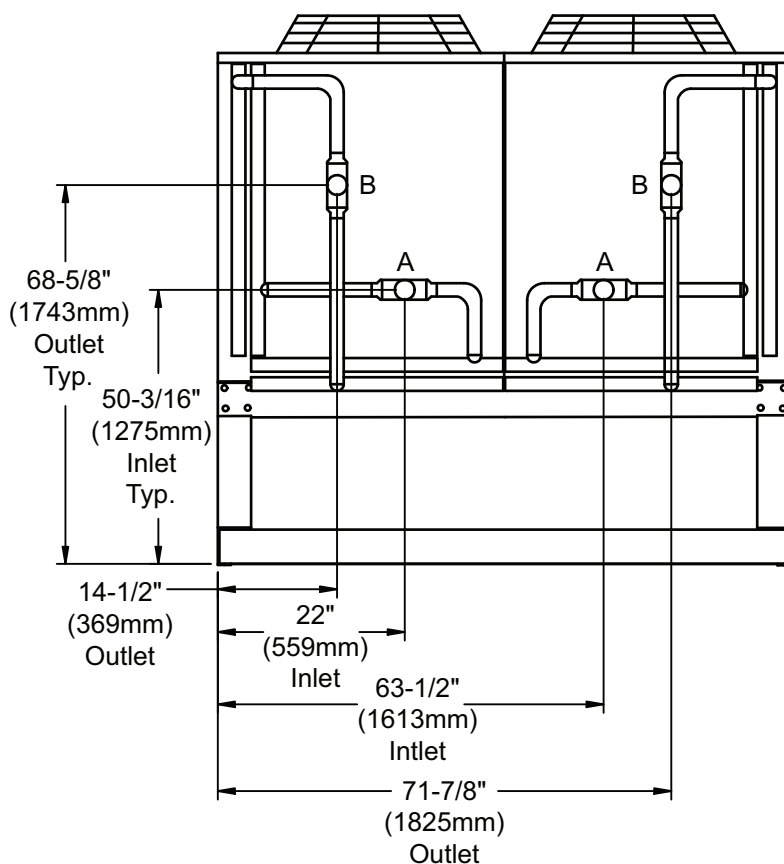

DPN000986  
REV. 0

Table 9 Piping, drycoolers

Model #.	No. Fans	No. of Internal Circuits	No. of Inlets	No. of Outlets	Connection Sizes (ODS)	
					(A) Inlet	(B) Outlet
D*N*150**068	10	68	2	2	2.625" (66.7mm)	2.625" (66.7mm)
D*N*150**136	10	136	2	2	4.125" (104.8mm)	4.125" (104.8mm)
D*N*150**272	10	272	2	2	4.125" (104.8mm)	4.125" (104.8mm)
DGN*120**068	10	68	2	2	2.625" (66.7mm)	2.625" (66.7mm)
DGN*120**136	10	136	2	2	4.125" (104.8mm)	4.125" (104.8mm)
DGN*120**272	10	272	2	2	4.125" (104.8mm)	4.125" (104.8mm)

**Table 10 Piping specifications**

Model	No. of Internal Circuits	No. of Inlets (A)	No. of Outlets (B)	Connection Sizes, Inlet and Outlet OD (in.)*	Coil Internal Volume, Gal. (l)
D0N*150**	68	2	2	2.625	92.8 (351)
DTN*150**	136			4.125	
DGN*120**	272				

\*Cut off closed end of connection tube; connect couplings and elbows as required.

**Table 11 Volume in standard Type L copper piping**

Diameter (in.)		Volume	
Outside	Inside	gal/ft	l/m
1-3/8	1.265	0.065	0.81
1-5/8	1.505	0.092	1.15
2-1/8	1.985	0.161	2.00
2-5/8	2.465	0.248	3.08
3-1/8	2.945	0.354	4.40
3-5/8	3.425	0.479	5.95
4-1/8	3.905	0.622	7.73

## 3.6 Filling Instructions

### 3.6.1 Preparing the System for Filling

It is important to remove any dirt, oil or metal filings that may contaminate the cooling system piping in order to prevent contamination of the fresh glycol solution and fouling of the drycooler piping. The system should be flushed thoroughly using a mild cleaning solution or high-quality water and then completely drained before charging with glycol. Cleaning new systems is just as important as cleaning old ones. New systems can be coated with oil or a protective film; dirt and scale are also common. Any residual contaminants could adversely affect the heat transfer stability and performance of your system. In many cases, in both old and new systems, special cleaners are needed to remove scale, rust and hydrocarbon foulants from pipes, manifolds and passages. Clean heat transfer surfaces are important in maintaining the integrity of the heating/cooling system. For more information on cleaners and degreasers, contact your sales representative. Follow the manufacturer's instructions when using these products.

Calculate the internal volume of the system as closely as possible. The Liebert® 10 Fan Drycooler™ volume, not including the load or field-supplied piping, is 92.8 gallons (351 l). Use **Table 11** for field-installed piping volumes.

### 3.6.2 Glycol Solutions



#### NOTE

*Glycol solutions should be considered for the protection of the coil. When glycol solutions are not used, damage can occur either from freezing or from corrosion from water.*

When considering the use of any glycol products in a particular application, you should review the latest Material Safety Data Sheets and ensure that the use you intend can be accomplished safely. For Material Safety Data Sheets and other product safety information, contact the supplier nearest you. Before handling any other products mentioned in the text, you should obtain available product safety information and take necessary steps to ensure safety of use.

## NOTICE

Risk of improper handling of glycol. Can cause environmental damage.

When mishandled, glycol products pose a threat to the environment. Before using any glycol products, review the latest Material Safety Data Sheets and ensure that you can use the product safely. Glycol manufacturers request that the customer read, understand and comply with the information on the product packaging and in the current Material Safety Data Sheets. Make this information available to anyone responsible for operation, maintenance and repair of the drycooler and related equipment.

## NOTICE

Risk of using improper glycol. Can cause equipment damage.

Automotive antifreeze is unacceptable and must NOT be used.

No chemical should be used as or in a food, drug, medical device, or cosmetic, or in a product or process in which it may contact a food, drug, medical device, or cosmetic until the user has determined the suitability and legality of the use. Since government regulations and use conditions are subject to change, it is the user's responsibility to determine that this information is appropriate and suitable under current, applicable laws and regulations.

Typical inhibited formula ethylene glycol and propylene glycol manufacturers and suppliers are Union Carbide (Ucartherm) and Dow Chemical (Dowtherm SR-1, Dowfrost). These glycols are supplied with corrosion inhibitors and do not contain a silicone anti-leak formula. Commercial ethylene glycol, when pure, is generally less corrosive to the common metals of construction than water itself. Aqueous solutions of these glycols, however, assume the corrosivity of the water from which they are prepared and may become increasingly corrosive with use when not properly inhibited.

There are two basic types of additives:

- Corrosion inhibitors and
- Environmental stabilizers

The corrosion inhibitors function by forming a surface barrier that protects the metals from attack. Environmental stabilizers, while not corrosion inhibitors in the strictest sense of the word, decrease corrosion by stabilizing or favorably altering the overall environment. An alkaline buffer, such as borax, is a simple example of an environmental stabilizer, since its prime purpose is to maintain an alkaline condition (pH above 7).

The percentage of glycol to water must be determined by using the lowest design outdoor temperature in which the system is operating. **Table 12** indicates the solution freeze point at several concentration levels of ethylene glycol. Propylene glycol concentrations should be 1% higher than ethylene glycol table values to find the freeze point. For example, 41% propylene glycol freezes at -10°F.

**Table 12 Ethylene glycol concentrations**

% Glycol by Volume	0*	10	20	30	40	50
Freezing Point °F (°C)	32 (0)	25 (-3.9)	16 (-8.9)	5 (-15.0)	-10 (-23.3)	-32 (-35.5)
Apparent Specific Gravity @ 50°F (10°C)	1	1.014	1.028	1.042	1.057	1.071

\* A minimal amount of glycol should be considered for inhibitive coil protection.

## NOTICE

Risk of poor water quality. Can cause equipment damage.

The quality of water used for dilution must be considered because water may contain corrosive elements that reduce the effectiveness of the inhibited formulation. Surface water that is classified as soft (low in chloride and sulfate ion content—less than 100 ppm each) should be used.

### 3.6.3 Filling the System

Emerson® recommends installing hose bibs at the lowest point of the system.

When filling a glycol system, keep air to a minimum. Air in glycol turns to foam and is difficult and time-consuming to remove. (Anti-foam additives are available and may be considered.)

Open all operating systems to the loop. With the top vent(s) open, fill the system from the bottom of the loop. This will allow the glycol to push the air out of the top of the system, minimizing trapped air. Fill to approximately 80% of calculated capacity. Fill slowly from this point, checking fluid levels until full.



#### NOTE

*For glycol solution preparation and periodic testing, follow manufacturer's recommendations. Do not mix products of different manufacturers.*

## 3.7 Electrical Connections

Each unit is shipped from the factory with all internal unit wiring completed. Refer to the electrical schematic when making connections. All wiring must be done in accordance with the National Electric Code and all local and state codes.



### WARNING

Risk of electric shock. Can cause injury or death. Disconnect all local and remote electric power supplies before working within the unit.

The fans may start unexpectedly. The line side of the factory disconnect remains energized when the disconnect is Off. Use a voltmeter to confirm that the electric power is turned Off before making any electrical connections.

### 3.7.1 Line Voltage

Drycooler rated voltage should be verified with available power supply upon receipt of unit but before installation. Refer to the unit electrical schematic and serial tag for specific electrical requirements. All wiring must be done in accordance with the National Electric Code as well as all local and state codes.



### CAUTION

Risk of using improper wire. Can cause equipment damage or a safety hazard from overheated wire and/or connections.

Size the system electrical service for the total of all drycoolers and ancillary components FLA/WSA/OPD. Unit-specific wiring diagrams are provided on each unit. Use copper wiring only. Make sure that all connections are tight.

Line voltage electrical service is required for all drycoolers at the location of the drycooler. The power supply does not necessarily have to be the same voltage supply as required by the indoor unit for which the drycooler operates. This power source may be 208, 230, 460 or 575V 60Hz; or 380/415V 50Hz. A unit disconnect is standard. However, a site disconnect may be required per local code to isolate the unit for maintenance. Route the supply power to the site disconnect switch and then to the unit. Route the conduit through the hole provided in the cabinet. Connect earth ground to lug provided near terminal board. For units with multi-voltage transformer, the transformer connections should match (change if necessary) the local power supply. See **Figure 9**.



Figure 9 Electrical field connections

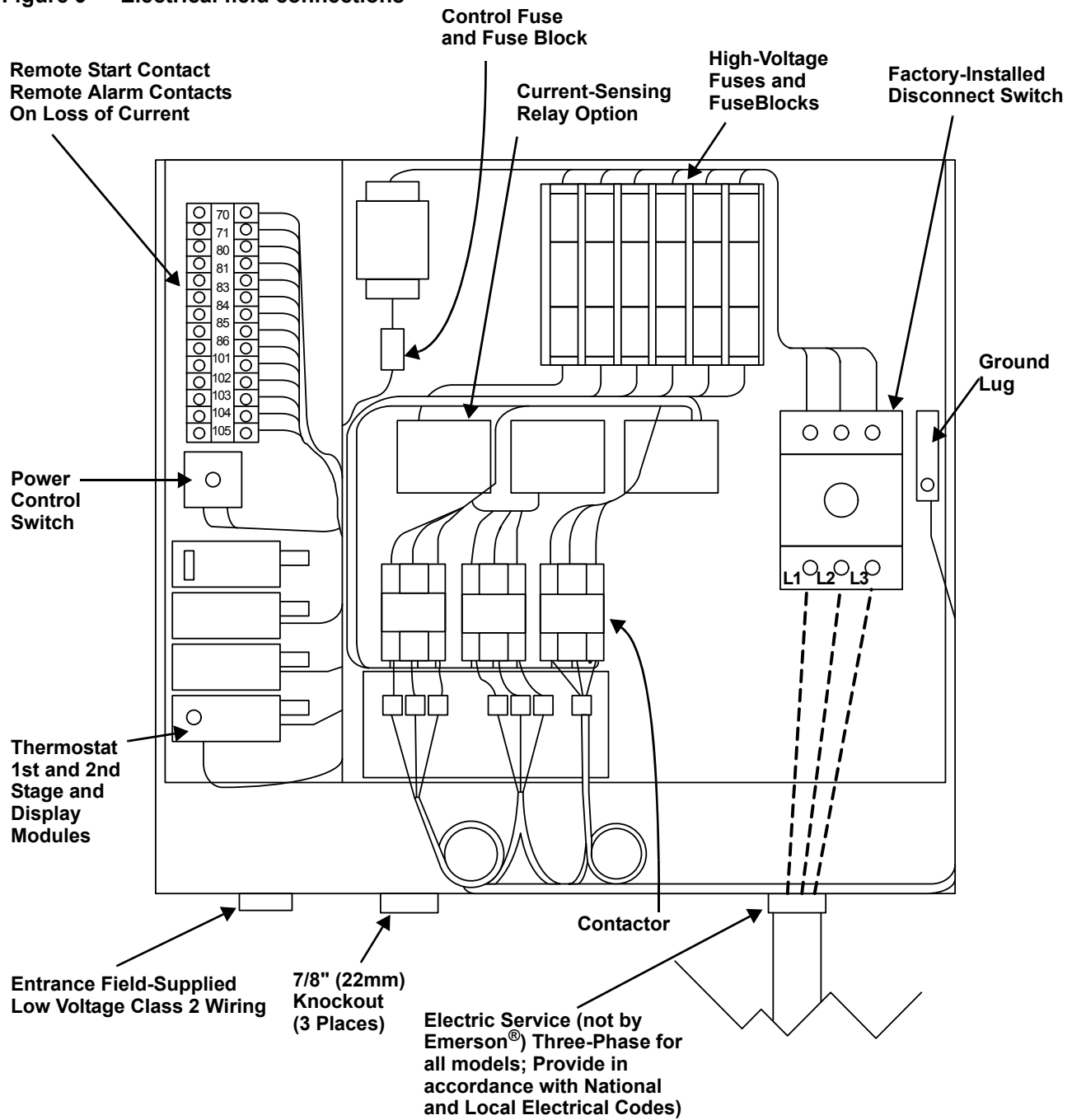

### 3.7.2 Low Voltage Control Wiring

A control interlock between the drycooler and the heat load(s) will require 24V Class 2 copper wiring for remote On/Off sequencing of the drycooler with the load. Refer to the electrical schematic for wiring to Terminals 70 & 71. See **Figure 10** for typical low-volt system wiring.

If the current sensing relay option is provided, 24V Class 2 wiring will be necessary to make the connections to monitor motor operation.



**NOTE**

*Make sure all electrical connections are tight.*

**Figure 10** Typical low volt wiring diagram

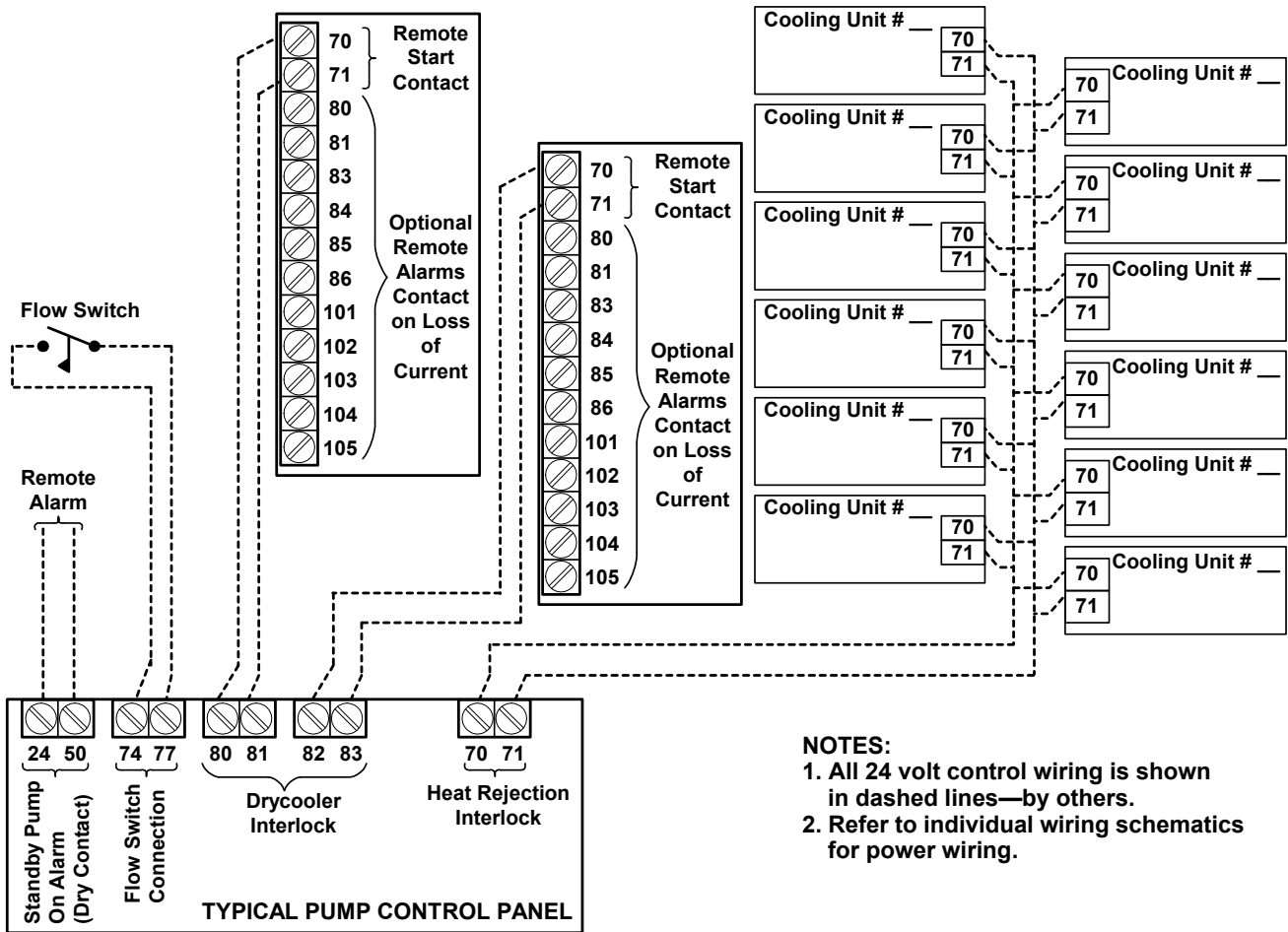

- NOTES:**
1. All 24 volt control wiring is shown in dashed lines—by others.
  2. Refer to individual wiring schematics for power wiring.

### 3.8 Checklist for Completing Installation

**NOTE**

*After installation, proceed with the following list to verify that the installation is complete. Complete and return the Warranty Inspection Check Sheet which is shipped with the unit and return to the address indicated on the check sheet.*

- 1. Proper clearances for service access have been maintained around the equipment.
- 2. Equipment is level and mounting fasteners are tight.
- 3. Piping completed to coolant loop.
- 4. All piping connections are tight as well as secured and isolated for vibration reduction.
- 5. All piping connections inspected for leaks during initial operation.
- 6. Line voltage to power wiring matches equipment nameplate.
- 7. Power wiring connections completed to disconnect switch, including earth ground.
- 8. Power line circuit breakers or fuses have proper ratings for equipment installed.
- 9. Control wiring connections completed to heat loads/evaporator(s), including wiring to optional controls.
- 10. All wiring connections are tight.
- 11. Foreign materials have been removed from in and around all equipment installed (shipping materials, construction materials, tools, etc.).
- 12. Fans rotate freely and in correct direction without unusual noise and discharge the air upwards.
- 13. Glycol has been added to the drycooler to prevent freeze damage.

## 4.0 OPERATION



### WARNING

Risk of electric shock. Can cause injury or death. Disconnect all local and remote electric power supplies before working within the unit.

The fans may start unexpectedly. Disconnect the power supply before working on the unit. Line side of factory disconnect remains energized when the disconnect is Off. Use a voltmeter to make sure power is turned off before checking any electrical connections or functions.

### 4.1 Initial Startup Procedure

Refer to **3.8 - Checklist for Completing Installation** and verify that all installation items have been completed prior to proceeding.

Turn the unit ON. Check the fans for proper rotation (air discharging up). Check the pumps for proper rotation.

### NOTICE

Risk of overheated pumps. Can cause equipment damage.

Do not run pumps without fluid in the system. Pump seals require fluid to keep them cool; running them for any amount of time will damage the seals, which may cause a failure.

#### 4.1.1 Control Setpoints

The fluid temperature controls should be set according to **Table 13** for standard cooling only or free-cooling GLYCOOL applications. See **Figure 11**.

**Table 13 Control settings**

Heat Rejection Method	Fluid Temperature Control	Setpoint	Offset	Differential	Open	Close
Standard	1TAS	68°F (20°C)	-	12°F (6.7°C)	68°F (20°C)	80°F (26.7°C)
	1STG	-	5°F (2.8°C)		73°F (22.8°C)	85°F (29.4°C)
	2STG	-	10°F (5.6°C)		78°F (25.6°C)	90°F (32.2°C)
Free-Cooling (GLYCOOL)	1TAS	42°F (5.6°C)	-	8°F (4.4°C)	42°F (5.6°C)	50°F (10°C)
	1STG	-	2°F (1.1°C)		44°F (6.7°C)	52°F (11.1°C)
	2STG	-	4°F (2.2°C)		46°F (7.8°C)	54°F (12.2°C)

Figure 11 Fluid temperature controls

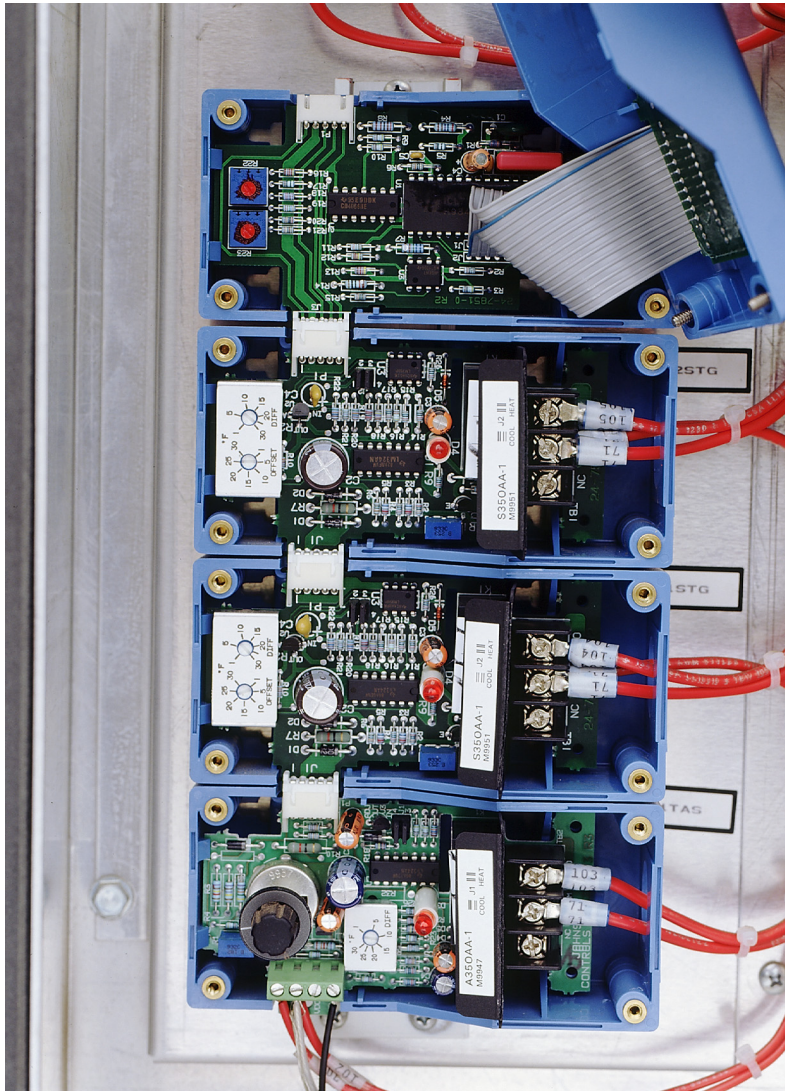

### 4.1.2 Current-Sensing Relays

If supplied, be sure that the current-sensing relays (CSR) are wired as per the wiring schematic using 24V Class 2 copper wiring. When the thermostat closes, a 24-volt signal will be sent to the relevant terminals of the CSR. When this occurs, a time delay starts, allowing the amperage to be sensed on the load side of the contactors.

First, set selection under amperage on selector switch, then start all fans. Set the trip delay for 50%. Disconnect one of the load side wires from a fan being monitored by the control. Turn the potentiometer until the LED is lit. Reconnect the fan wire. Check and repeat for the other circuits. Be sure to set the fluid temperature controls as per the specifications, as illustrated within the unit electrical schematic (supplied with the unit), or refer to **4.1.1 - Control Setpoints** and **Table 13**. See **Figure 12** for current sensing relay layout.

Figure 12 Current sensing relays

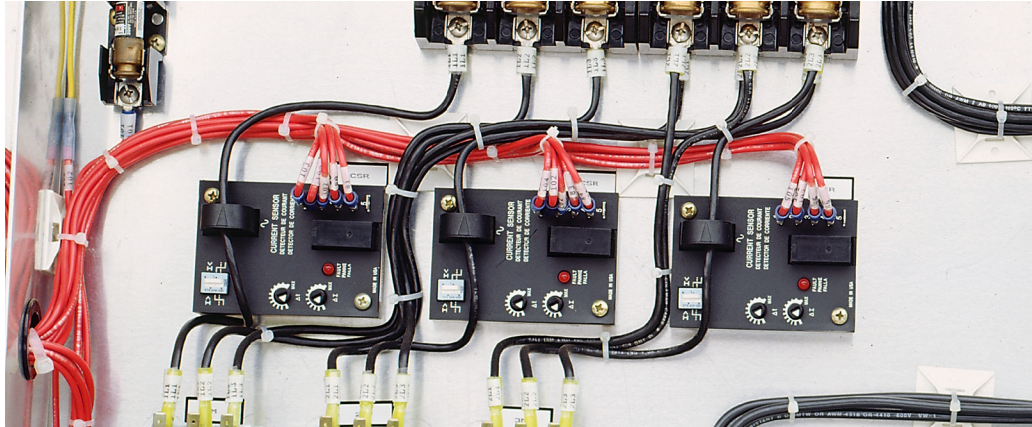

### 4.1.3 Cold Weather Operation

Glycol solution should be used for operation of units located where outdoor ambients will include temperatures at or below freezing. Refer to the installation sections referring to piping (**3.5 - Piping Connections**) and glycol solutions (**3.6.2 - Glycol Solutions**) for further details.

## 5.0 SYSTEM MAINTENANCE



### WARNING

Risk of electric shock. Can cause injury or death. Disconnect all local and remote electric power supplies before working within the unit.

The fans may start unexpectedly. Disconnect power supply before working on unit. Line side of factory disconnect remains energized when disconnect is off. Use a voltmeter to make sure power is turned off before checking any electrical connections or functions

## 5.1 General Procedures



### NOTE

*When ordering replacement parts for equipment, it is necessary to specify the unit's model number, serial number and voltage. Record those numbers in the spaces below.*

- Model Number \_\_\_\_\_
- Serial Number \_\_\_\_\_
- Voltage \_\_\_\_\_

Periodic attention is necessary for continued satisfactory operation of your unit. A daily inspection of the system should be made to verify that the unit is performing satisfactorily. It is suggested that a daily log be maintained recording inlet and outlet coolant temperature, ambient temperature and the coolant pressure gauge readings. The coolant sight glass should be checked and the fans checked for unusual sounds which may indicate wear or future trouble.

Monthly inspections should include removal and cleaning of strainer, and cleaning and inspection of coil. The coil can be cleaned with water, compressed air or steam as required. During monthly inspections, it is also wise to check the coolant to assure sufficient glycol in the mixture to prevent freeze-up. Each fan motor amp draw should be checked. If performance or operation problems are also detected, refer to **6.0 - Troubleshooting** for required action. Use copies of **5.2.2 - Maintenance Inspection Checklist**

Restricted air flow through the drycooler coil will reduce the operating efficiency of the unit and can result in high fluid temperatures and loss of cooling. Clean the drycooler coil of all debris that will inhibit air flow. This can be done with compressed air or a commercial coil cleaner. Check for bent or damaged coil fins and repair as necessary. In winter, do not permit snow to accumulate around the sides or underneath the drycooler.

Check all fluid lines and capillaries for vibration isolation. Support as necessary. Visually inspect all fluid lines for signs of fluid leaks.

Inspect the motor/fan assemblies to insure bearings are free and the motor is secure within the mount.

The glycol level in drycooler systems must be periodically checked. At the high point of the system, check for:

- Positive pressure
- Air to be vented
- An unclogged expansion tank
- Proper concentration of inhibitors and antifreeze

The first three checks may give an indication of leaks in the system.

## 5.2 Special Procedures

### 5.2.1 Drycooler Cleaning

Keeping the outdoor drycooler coils clean is an important factor in maintaining peak efficiency, reliability and long life of the equipment. It is much easier to keep up on frequent cleanings rather than wait until heavy build up has occurred which may create head pressure problems with the evaporator units.

#### When to Clean

Normal conditions typically dictate cleaning twice a year, spring and fall. On-site or area conditions such as cottonwood trees, construction, etc., can increase cleaning frequency. On your standard bimonthly or quarterly preventive maintenance schedule, a visual inspection of the coil is recommended to monitor conditions.

#### What to Use

The best overall condenser coil cleaner to use is plain water. If the coil has been maintained and cleaned at regular intervals, water is sufficient to remove dirt and debris from the fins. Heavy buildup on the exterior of the fins can be removed with a brush. Water pressure from a garden hose and sprayer usually works well. If a pressure washer is used, make sure the equipment is set to a lower pressure setting and that the nozzle is set to the fan spray, not stream. Otherwise, damage to the fins could result. If a cleaner is required, Emerson® recommends using a non-acidic type cleaner. Acid-type cleaners can be aggressive to the coil fins as well as surrounding areas. Many sites do not allow the use of acidic cleaners for environmental reasons.

#### How to Clean

The best way to clean coils is from the inside out. This requires removing the coil guards or grilles (if provided), the fan guards and blades to access the coil surface. The sprayer can then be worked across the coil pushing the dirt and debris out. Although this does extend the time involved, the results are well worth it. This method should be used at least once a year. Spraying the coil from the outside repeatedly can push a majority of the dirt to the inner section of the fins and continue to restrict air flow. Keep in mind you may not have the luxury of shutting the unit(s) down for an extended time. A scheduled shutdown with the operator may be in order. If using a cleaner along with the spraying process, follow recommended manufacturer instructions and be sure to rinse the coil thoroughly. Any residue left on the coil can act as a magnet to dirt.



**5.2.2 Maintenance Inspection Checklist**

Date: \_\_\_\_\_

Prepared By: \_\_\_\_\_

Model #: \_\_\_\_\_

Serial Number: \_\_\_\_\_



**NOTE**

*Regular inspections are necessary to assure proper cleanliness of the cooling fins. Should inspection reveal dirt or corrosion, appropriate cleaning should be performed.*

Monthly	Semiannually
<p><b>Drycooler</b></p> <ul style="list-style-type: none"> <li>___ 1. Coil surfaces free of debris</li> <li>___ 2. Fans/grilles free of debris</li> <li>___ 3. Fan motors securely mounted</li> <li>___ 4. Motor bearings in good condition</li> <li>___ 5. No water/glycol leaks</li> </ul> <p><b>Pump Package</b></p> <ul style="list-style-type: none"> <li>___ 1. Pump rotation</li> <li>___ 2. Pump securely mounted</li> <li>___ 3. No water/glycol leaks</li> <li>___ 4. No abnormal noises</li> </ul>	<p><b>Drycooler</b></p> <ul style="list-style-type: none"> <li>___ 1. Complete all monthly items</li> <li>___ 2. Piping in good condition</li> <li>___ 3. Piping secure</li> <li>___ 4. Wash coil as needed</li> </ul> <p><b>Pump Package</b></p> <ul style="list-style-type: none"> <li>___ 1. Complete all monthly items</li> <li>___ 2. Test changeover operation</li> <li>___ 3. Pump #1 amp draw _____ Pump #2 amp draw _____ Pump #3 amp draw _____</li> <li>___ 4. Glycol level and general condition</li> <li>___ 5. Glycol freeze point ___°F and pH ____</li> <li>___ 6. Check all electrical connections</li> <li>___ 7. Check contactors for pitting</li> </ul> <p><b>Drycooler Electric Panel</b></p> <ul style="list-style-type: none"> <li>___ 1. Check all electrical connections</li> <li>___ 2. Check contactors for pitting</li> <li>___ 3. Operational sequence/setpoints</li> </ul> <p><b>Fan Motors</b></p> <ul style="list-style-type: none"> <li>___ 1. Motor #1 amp draw _____ amps</li> <li>___ 2. Motor #2 amp draw _____ amps</li> <li>___ 3. Motor #3 amp draw _____ amps</li> <li>___ 4. Motor #4 amp draw _____ amps</li> <li>___ 5. Motor #5 amp draw _____ amps</li> <li>___ 6. Motor #6 amp draw _____ amps</li> <li>___ 7. Motor #7 amp draw _____ amps</li> <li>___ 8. Motor #8 amp draw _____ amps</li> <li>___ 9. Motor #9 amp draw _____ amps</li> <li>___ 10. Motor #10 amp draw _____ amps</li> </ul>

**Notes:**

**Signature:** \_\_\_\_\_

Make photocopies of this form for your records

## 6.0 TROUBLESHOOTING

Symptom	Possible Cause	Check Or Remedy
Unit will not operate	No main power	Check L1, L2 and L3 for rated voltage
	Disconnect switch open	Close disconnect switch
	Blown fuse or circuit breaker tripped	Check fuses or circuit breaker
	Control fuse or circuit breaker tripped	Check for 24VAC. If no voltage, check for short. Replace fuse or reset circuit breaker.
	Improperly wired	Check wiring diagram
	No output voltage from transformer	Check for 24VAC. If no voltage, check primary voltage
Unit runs, but motor protector keeps tripping	Motor protector defective	Replace protector
	Motor protector too small	Check amp. draw
	Fan or pump motor has shorted winding	Repair motor
	Low or unbalanced voltage	Determine reason and correct
Outlet temperature from unit too high	Low or no coolant flow	See <b>Pump will not operate or no coolant flow</b> entry in this table
	Ambient air temperature higher than design	Correct possible hot air discharge to fans from another source
	Heat load higher than design	Check for misapplication, need larger cooler. Correct possible additional heat load being added to cooling circuit.
	Throttling valve improperly	Reset valve to proper differential pressure
Liquid squirts from surge tank fill cap when pump is turned off	Air in system	Vent all high points, repeat as necessary. Check liquid level in surge tank.
Pump suddenly stops pumping	Clogged strainer or impeller	Clean out debris
Pumping suddenly slows	Clogged impeller, diffuser or line	Clean out debris and use strainer
Excessive leakage around the pump shaft while operating	Worn seal or packing	Replace seal or packing
Pump performance poor	Worn impeller or seal	Replace with new impeller or seal
	Suction lift too high	Relocate pump closer to supply
	Motor not up to speed; low voltage	Larger lead wires may be required. Check for proper line voltage, $\pm 10\%$
	Worn bearings	Replace pump
Pump has noisy operation	Worn motor bearings	Replace pump
	Low discharge head	Throttle discharge -- improve conditions
	Debris lodged in impeller	Remove cover and clean out
	Cavitating pumps	Adjust system pressures
Pump discharge pressure too high	Throttling valve improperly set	Reset valve to proper differential pressure
	Valve closed in circuit	Open all valves downstream of unit
	Strainer clogged or dirty	Remove strainer plug and clean
Pump will not operate or no coolant flow	No power to pump motor	See <b>Unit will not operate</b> in this table
	Low coolant level	Check coolant level
	Tubes plugged in cooling coil	Flush coil with reputable cleaner
	Valve closed downstream of cooling unit	Open all valves
	Strainer clogged or dirty	Remove strainer plug and clean
	Pump cavitating (erratic gauge operation)	Possibility of air in lines. Bleed all components. Check surge tank to pump inlet connection. Check for piping restrictions.



# Ensuring The High Availability Of Mission-Critical Data And Applications.

Emerson Network Power, a business of Emerson (NYSE:EMR), is the global leader in enabling *Business-Critical Continuity™* from grid to chip for telecommunication networks, data centers, health care and industrial facilities. Emerson Network Power provides innovative solutions and expertise in areas including AC and DC power and precision cooling systems, embedded computing and power, integrated racks and enclosures, power switching and controls, infrastructure management, and connectivity. All solutions are supported globally by local Emerson Network Power service technicians. Liebert AC power, precision cooling and monitoring products and services from Emerson Network Power deliver Efficiency Without Compromise™ by helping customers optimize their data center infrastructure to reduce costs and deliver high availability.

While every precaution has been taken to ensure the accuracy and completeness of this literature, Liebert Corporation assumes no responsibility and disclaims all liability for damages resulting from use of this information or for any errors or omissions.

© 2009 Liebert Corporation

All rights reserved throughout the world. Specifications subject to change without notice.

® Liebert is a registered trademark of Liebert Corporation.

All names referred to are trademarks or registered trademarks of their respective owners.

SL-10061\_REV2\_07-12

## Technical Support / Service

### Web Site

[www.liebert.com](http://www.liebert.com)

### Monitoring

[liebert.monitoring@emerson.com](mailto:liebert.monitoring@emerson.com)

800-222-5877

Outside North America: +00800 1155 4499

### Single-Phase UPS & Server Cabinets

[liebert.upstech@emerson.com](mailto:liebert.upstech@emerson.com)

800-222-5877

Outside North America: +00800 1155 4499

### Three-Phase UPS & Power Systems

800-543-2378

Outside North America: 614-841-6598

### Environmental Systems

800-543-2778

Outside the United States: 614-888-0246

### Locations

#### United States

1050 Dearborn Drive

P.O. Box 29186

Columbus, OH 43229

#### Europe

Via Leonardo Da Vinci 8

Zona Industriale Tognana

35028 Piove Di Sacco (PD) Italy

+39 049 9719 111

Fax: +39 049 5841 257

#### Asia

29/F, The Orient Square Building

F. Ortigas Jr. Road, Ortigas Center

Pasig City 1605

Philippines

+63 2 687 6615

Fax: +63 2 730 9572

## Emerson Network Power.

The global leader in enabling *Business-Critical Continuity™*

- |              |   |                            |                             |
|--------------|---|----------------------------|-----------------------------|
| AC Power     | Embedded Computing                                | Outside Plant              | Racks & Integrated Cabinets |
| Connectivity | Embedded Power                                    | Power Switching & Controls | Services                    |
| DC Power     | <b>Infrastructure Management &amp; Monitoring</b> | Precision Cooling          | Surge Protection            |