

## QUICK START

Labels *above* the controls refer to the unit being operated in the 2- or 3-Way *Stereo* mode. Labels *below* the controls refer to the unit being operated in the 4- or 5-Way *Mono* mode.

Set the STEREO/MONO switch appropriately. The fact that the AC 23B is a multiple function unit means the outputs are switched around in Mono mode.

To operate the unit in Stereo 3-Way mode, be sure the rear panel switches are set for STEREO 3-WAY. Following the labels *above* the controls and jacks in logical order, you will find Channel 1 Master Input LEVEL, LOW Output, MID Output, and HIGH Output, with the same for Channel 2. If you need a summed Mono Low Output, see ‘Monoing the Low Outputs’ on page Manual-7.

To use the unit as a Mono 5-Way, first check that the CHANNEL 1 and 2 switches are set to 3-WAY, and the other switch is set to MONO. Connect the INPUT source to CHANNEL 1 *only*. Following the labels *below* the jacks, look at SUB OUT, then look over at LOW OUT, now go back to MID OUT, then over to HIGH-MID OUT and then proceed to the HIGH OUT. An internal switch determines 4 or 5-Way mode. Our apologies to 4-Way users: We must ship the units in the 5-Way mode since normal Stereo 3-Way operation demands it: a fact not the least bit obvious, but nevertheless, a fact it remains. Pity. See page Manual-6 for Mono 4-Way configuration.

In agreement with IEC and AES/ANSI standards, AC 22B wiring convention is pin 2 Positive, pin 3 Negative (return), pin 1 chassis ground. See the “Sound System Interconnection” RaneNote included with this manual for more information on cabling and grounding requirements.

**CAUTION:** *Never connect anything except an approved Rane Power supply to the thing that looks like a red telephone jack on the rear of the AC 23B.* This is an 18 VAC center tapped power input. Consult the Rane factory for a replacement or substitution.

# FRONT PANEL: STEREO 2-WAY CONFIGURATION

Stereo 2-Way labels in this row.

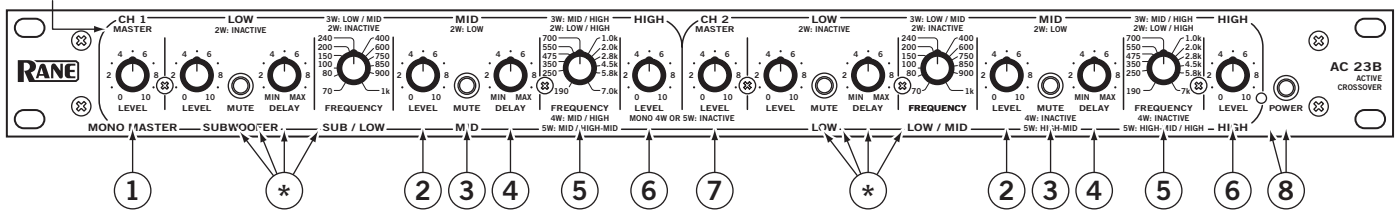

Observe the labels *above* the controls for stereo operation.

## \* Not used in 2-Channel 2-Way Mode

- ① **Channel 1 MASTER LEVEL control:** Sets the overall Level of Channel 1 without altering the relative settings of the Low and High frequency Outputs. Unity gain for all level controls is at “7”.
- ② **LOW LEVEL control:** Sets the Level of signal going to the Low Frequency output in this channel. Refer to ‘Setting the Output Level Controls’ on page Manual-15.
- ③ **LOW MUTE switch:** When pressed to the *in* position, all signal is removed from the Low Frequency Output. This eases tune-up procedures as described on pages Manual-11-16.
- ④ **LOW DELAY control:** Adds from 0 to 2 ms of time Delay to the Low Frequency Output only. This allows a low frequency driver to be electronically phase-aligned with a mid frequency driver whose diaphragm is situated *behind* the low frequency diaphragm. Refer to ‘Time Delay Adjustment Procedure’ on page Manual-10.
- ⑤ **LOW/HIGH crossover frequency selector:** This 41-detent selector sets the crossover frequency between the Low and High frequency Outputs. Refer to ‘Selecting Crossover Frequencies’ on page Manual-10.
- ⑥ **HIGH LEVEL control:** Sets the Level of signal going to the High frequency Output only.
- ⑦ **Channel 2 MASTER LEVEL control:** Sets the overall Level of Channel 2 without altering the relative settings of the Low and High Outputs.
- ⑧ **POWER switch and indicator:** Two guesses. When this yellow LED is lit, you guessed right — the unit is on and ready.

# REAR PANEL: STEREO 2-WAY INSTALLATION

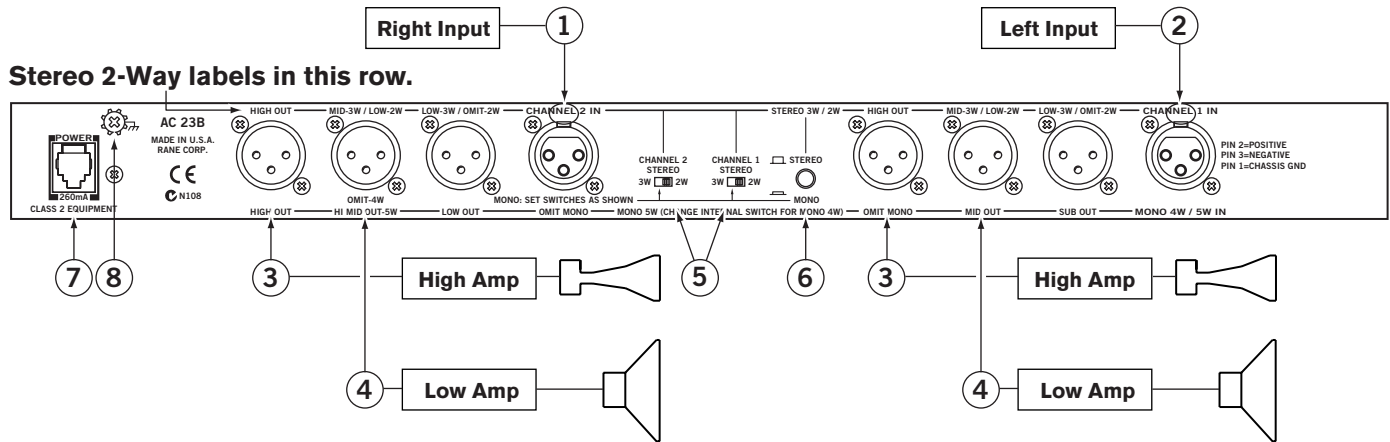

Observe the labels *above* the Inputs and Outputs for Stereo operation.

- ① **CHANNEL 1 INPUT:** Plug the left output of the mixer, equalizer or other signal source to this Input. See ‘AC 23B Connection’ on page Manual-1 for wiring details.
- ② **CHANNEL 2 INPUT:** Plug the right output of the mixer, equalizer or other signal source to this Input..
- ③ **HIGH FREQUENCY OUTPUTS:** Connect the CHANNEL 1 HIGH OUT to the left channel input of the high frequency amp, and the CHANNEL 2 HIGH OUT to the right channel input of the high frequency amp.
- ④ **LOW FREQUENCY OUTPUTS:** Connect the CHANNEL 1 LOW-2Way Output to the left channel input of the low frequency amplifier, and the CHANNEL 2 LOW-2Way Output to the right channel input of the low amplifier. If you need a summed Mono Low Output, see ‘Monoing the Low Outputs’ on page Manual-7.
- ⑤ **2-Way/3-Way switch:** Converts the outputs from 3-Way to 2-Way. This switch removes the Low frequency crossover from the signal path. Low frequencies are now routed to the Mid frequency Output. Be sure to slide the switches to the 2-Way position. *Note: The Low frequency outputs are still active and may be used as additional subwoofer outputs.*
- ⑥ **STEREO/MONO switch:** Set this switch to the STEREO “out” position.
- ⑦ **POWER input connector:** Use only a model RS 1 or other power supply approved by Rane. This unit is supplied with a remote power supply suitable for connection to this input jack. This is not a telephone jack. The power requirements call for an 18-24 VAC center-tapped transformer only. Using any other type of unapproved supply may damage the unit and void the warranty. Two years parts and labor is worth safeguarding.
- ⑧ **Chassis ground point:** A #6-32 screw is used for chassis grounding purposes. Always connect crossover chassis ground to amplifier chassis ground. See ‘Chassis Grounding’ below for details.

## IMPORTANT NOTE

### CHASSIS GROUNDING

If after hooking up your system it exhibits excessive hum or buzzing, there is an incompatibility in the grounding configuration between units somewhere. Your mission, should you accept it, is to discover how your particular system wants to be grounded. Here are some things to try:

1. Try combinations of lifting grounds on units that are supplied with ground lift switches or links.
2. If your equipment is in a rack, verify that all chassis are tied to a good earth ground, either through the line cord grounding pin or the rack screws to another grounded chassis.
3. Units with outboard power supplies do not ground the chassis through the line cord. Make sure that these units are grounded either to another chassis which is earth grounded, or directly to the grounding screw on an AC outlet cover by means of a wire connected to a screw on the chassis with a star washer to guarantee proper contact.
4. Try moving the device away from high magnetic field sources, such as large transformers used in power amplifiers. Please refer to the included RaneNote “Sound System Interconnection” for further information on system grounding.

# FRONT PANEL: STEREO 3-WAY CONFIGURATION

Stereo 3-Way labels in this row.

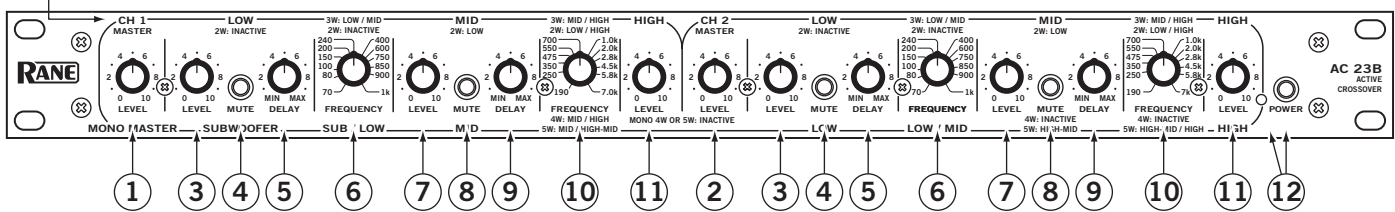

Observe the labels screened *above* the controls for stereo operation.

- ① **Channel 1 MASTER LEVEL control:** Sets the overall Level of Channel 1 without altering the relative settings of the Low/Mid/High frequency Outputs. Unity gain for all Level controls is at “7”.
- ② **Channel 2 MASTER LEVEL control:** Sets the overall Level of Channel 2 without altering the relative settings of the Low/Mid/High Outputs.
- ③ **LOW LEVEL control:** Sets the Level of signal going to the Low frequency Output only in this Channel. Refer to page Manual-15 for guidance with the Level control settings.
- ④ **LOW MUTE switch:** When pressed to the *in* position, all signal is removed from the Low frequency Output. This eases tune-up procedures as described on pages Manual-11-16.
- ⑤ **LOW DELAY control:** Adds from 0 to 2 ms of time delay to the Low Frequency Output only. This allows a low frequency driver to be electronically phase-aligned with a mid frequency driver whose diaphragm is situated *behind* the low frequency diaphragm. Refer to page Manual-10.
- ⑥ **LOW/MID crossover frequency selector:** This 41-detent selector sets the crossover frequency between the Low and Mid Outputs. Refer to page Manual-10.
- ⑦ **MID LEVEL control:** Sets the Level of signal going to the Mid Output in this Channel only.
- ⑧ **MID MUTE switch:** Removes all signal from the Mid Frequency Output when pressed to the *in* position.
- ⑨ **MID DELAY control:** Adds from 0 to 2 ms of time Delay to this Channel’s Mid Output.
- ⑩ **MID/HIGH crossover frequency selector:** Sets the frequency between the Mid and High Outputs in this Channel.
- ⑪ **HIGH LEVEL control:** Sets the Level of signal going to the High Output only.
- ⑫ **POWER switch and indicator:** Two choices: on or off. If the power supply is plugged in, this yellow LED is lit, and the POWER button is depressed, then the unit ready to operate.

## REAR PANEL: STEREO 3-WAY INSTALLATION

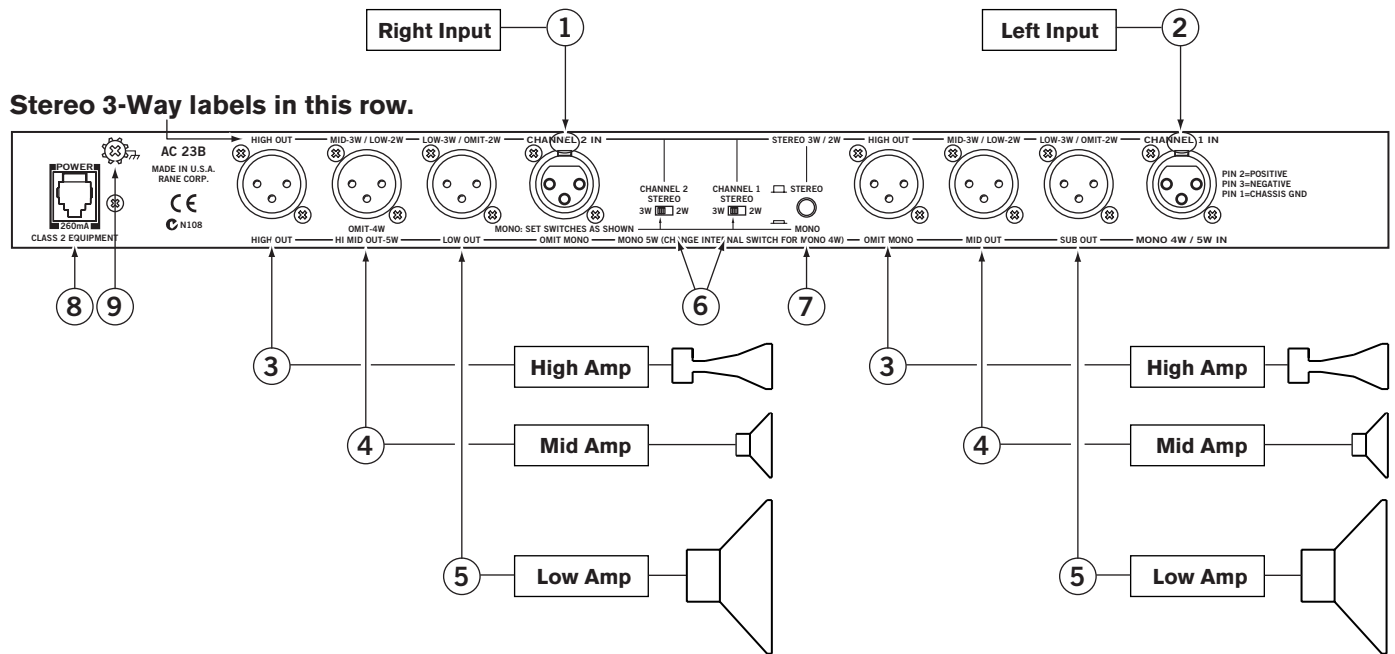

### Observe the labels *above* the Inputs and Outputs for Stereo operation.

- ① **CHANNEL 1 INPUT:** Plug the left output of the mixer, equalizer or other signal source to this Input. Refer to 'AC 23B Connection' on page Manual-1 for wiring details.
- ② **CHANNEL 2 INPUT:** Plug the right output of the mixer, equalizer or other signal source to this Input.
- ③ **HIGH OUTPUTS:** Connect the CHANNEL 1 HIGH OUT to the left channel input of the high frequency amp, and the CHANNEL 2 HIGH OUT to the right channel input of the high frequency amp.
- ④ **MID OUTPUTS:** Connect the CHANNEL 1 MID OUT to the left channel of the mid frequency amp, and the CHANNEL 2 MID OUT to the right channel of the mid frequency amp.
- ⑤ **LOW OUTPUTS:** Connect the CHANNEL 1 and 2 LOW OUTS to the left and right channels of the low frequency amplifier, respectively. If you need a summed Mono Low Output, see 'Monoing the Low Outputs' on page Manual-7.
- ⑥ **STEREO/MONO switch:** Set this switch to the STEREO position.
- ⑦ **2-WAY/3-WAY switch:** Converts the outputs from Stereo 3-Way to Stereo 2-Way. Be sure the switches are in the 3-WAY position.
- ⑧ **POWER input connector:** Use only a model RS 1 or other power supply approved by Rane. This unit is supplied with a remote power supply suitable for connection to this input jack. This is not a telephone jack. The power requirements call for an 18-24 VAC center-tapped transformer only. Using any other type of unapproved supply may damage the unit and void the warranty. Two years parts and labor is worth safeguarding.
- ⑨ **Chassis ground point:** A #6-32 screw is used for chassis grounding purposes. Always connect the crossover chassis to the amplifier chassis. See 'Chassis Grounding' on page Manual-3 for details.

# FRONT PANEL: MONO 4-WAY AND 5-WAY CONFIGURATION

Mono 4-Way and 5-Way labels in this row.

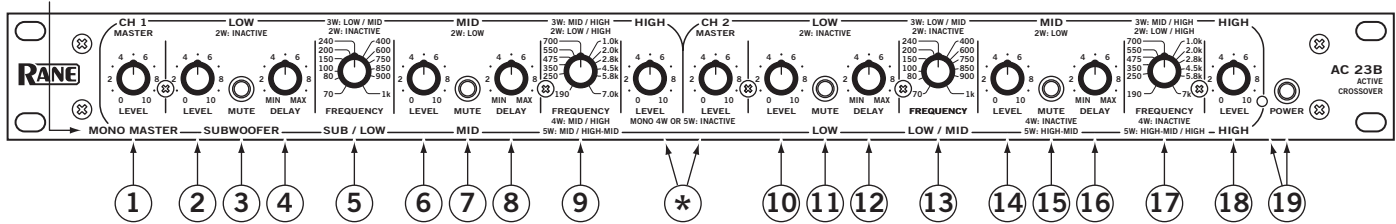

Observe the labels screened *below* the controls for Mono operation.

- ① **MASTER LEVEL control:** Sets the overall Level of the entire unit in Mono mode, without changing relative settings of the individual Sub/Low/Mid/High Outputs. Unity gain for all Level controls is “7”.
  - ② **SUBWOOFER LEVEL control:** Sets the Level of signal going to the Sub Output. See page Manual-15.
  - ③ **SUBWOOFER MUTE switch:** Removes all signal from the Sub Output when pressed to the *in* position. This eases the system tune-up procedure, as described on pages Manual-11-16.
  - ④ **SUBWOOFER DELAY control:** In Subwoofer applications this control has virtually no effect and will normally be set to MIN (minimum). Refer to page Manual-10.
  - ⑤ **SUB / LOW crossover frequency selector:** This 41-detent selector sets the crossover frequency between the Subwoofer and Low Outputs. Refer to page Manual-10 to determine the proper setting for your system.
  - ⑥ **LOW LEVEL control:** Sets the Level going to the Low frequency Output.
  - ⑦ **LOW MUTE switch:** Removes all signal from the Low Output when pressed *in*.
  - ⑧ **LOW DELAY control:** Adds from 0 to 2 ms of time Delay to the Low Output only. Refer to page Manual-10 for alignment procedure.
  - ⑨ **LOW / MID crossover frequency selector:** Sets the crossover frequency between the Low and Mid frequency Outputs.
  - ⑩ **MID LEVEL control:** Sets the Level of signal going to the Mid Output only.
  - ⑪ **MID MUTE switch:** Removes all signal from the Mid Output when pressed *in*.
  - ⑫ **MID DELAY control:** Adds from 0 to 2 ms of time Delay to the Mid frequency Output only.
  - ⑬ **MID / HIGH-MID crossover frequency selector:** Sets the crossover frequency between the Mid and High-Mid Outputs.
- \* *NOTE: Both the CHANNEL 1 HIGH LEVEL control and CHANNEL 2 MASTER LEVEL control are automatically bypassed when the AC 23B is switched to "MONO" on the back panel. Adjusting these controls has no effect in the Mono mode.*
- ⑭ **HIGH-MID LEVEL control:** This controls the Level of signal going to the High-Mid Output only in 5-Way Mode.  
 \*\**NOTE TO 4-WAY MONO USERS: An internal switch (S5) determines 4 or 5-Way mode. Our apologies: We must ship the units in the 5-Way mode since normal Stereo 3-Way operation demands it: a fact not the least bit obvious, but nevertheless, a fact it remains. See the Mono 4-Way Switch Instructions on the next page. The HIGH-MID LEVEL control, HIGH-MID MUTE switch, HIGH-MID DELAY control and HIGH-MID / HIGH FREQUENCY control are out of circuit and will have no effect regardless of their settings in 4-Way Mode.*

- ⑮ **HIGH-MID MUTE switch:** Removes all signal from the High-Mid Output when pressed to the *in* position. *This control is disabled in 4-Way mode.*
- ⑯ **HIGH-MID DELAY control:** This control adds from 0 to 2 ms of time Delay to the High-Mid Output only. *This control is disabled in 4-Way mode.*
- ⑰ **HIGH-MID/HIGH crossover frequency selector:** This control sets the crossover Frequency between the High-Mid and High Frequency Outputs. *This control is disabled in 4-Way mode.*
- ⑱ **HIGH LEVEL control:** This controls the Level of signal to the High Output only.
- ⑲ **POWER switch and indicator:** Two choices: on or off. If the power supply is plugged in, this yellow LED is lit, and the POWER button is depressed, then the unit ready to operate.

**See the Following Pages for Mono 4- or 5-Way Installation.**

### Mono 4-Way Switch Instructions

1. Be sure all power and audio is turned off. Remove the top cover of the AC 23B.
2. Locate the 4-WAY/5-WAY switch (see diagram).
3. Move the switch from the 5-WAY position to 4-WAY.
4. Replace the cover. The AC 23B is now set for Mono 4-Way Mode. The HIGH-MID OUTPUT duplicates the MID OUTPUT frequencies with a different low pass setting as determined by the HIGH-MID / HIGH FREQUENCY control, and is not normally recommended for use since the tweeter crossover point will be inaccurate.

**This operation must be reversed to operate the unit in either Stereo 3-Way or Mono 5-Way Mode.**

### Monoing the Low Outputs

It is possible to mono the Low Frequency Outputs of the AC 23B by an internal jumper. Set both Low Delays to "0".

1. Remove the power cord and the AC 23B top cover.
2. Move the header to the J10 mono sum position.
3. Moving the header to the SHIP position puts the Low Outputs back in stereo, as shipped from the factory.
4. Replace the cover.

The mono output is now at Channel 1 LOW OUT. Channel 2's LOW OUT is unused.

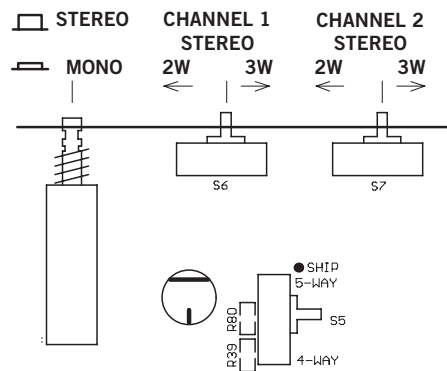

MONO SUB  
OPTION  
J10 [ ] ● SHIP



# REAR PANEL: MONO 4-WAY AND MONO 5-WAY INSTALLATION

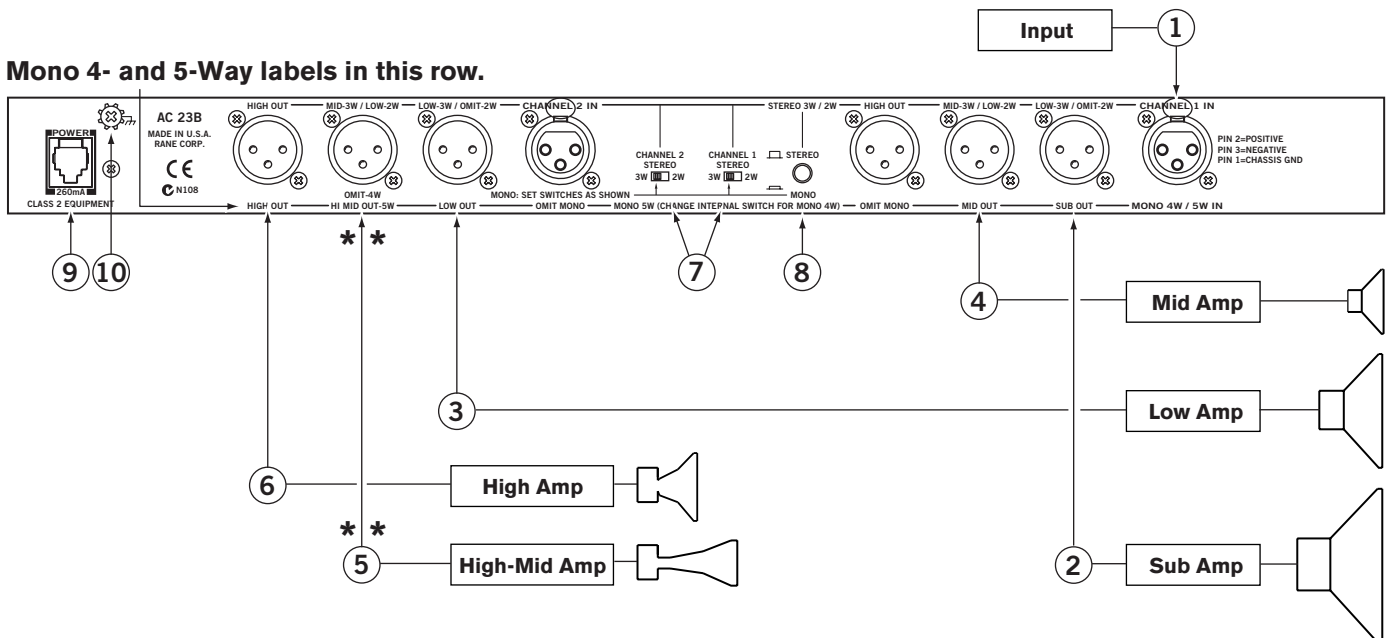

**\*\* THIS OUTPUT IS NOT USED FOR 4-WAY MONO OPERATION.**

**4-WAY USERS SEE INTERNAL SWITCH INSTRUCTIONS ON PREVIOUS PAGE.**

**Observe the labels *below* the Inputs and Outputs for Mono operation.**

- ① **MONO INPUT:** Connect the output from your mixer or other signal source only to the CHANNEL 1 INPUT for Mono operation; do not use the Channel 2 Input. See AC 23B CONNECTION on page Manual-1 for wiring details.
- ② **SUBWOOFER OUTPUT:** Connect the SUB OUT to the input of the subwoofer (or bass bin) amplifier.
- ③ **LOW OUTPUT:** Connect the LOW OUT to the input of the low frequency (mid-bass) amp.
- ④ **MID OUTPUT:** Connect the MID OUT to the input of the mid frequency amplifier.
- ⑤ **HIGH-MID OUTPUT (FOR MONO 5-WAY ONLY):** Use this Output only for Mono 5-Way applications. *Omit this output when using the AC 23B as a Mono 4-Way Crossover. Mono 4-Way Switch Instructions are on the previous page. In 4-Way the AC 23B internally bypasses the High-Mid section and defeats all front panel High-Mid Controls.* For Mono 5-Way connect the HIGH-MID OUT to the input of the high-mid frequency amplifier.
- ⑥ **HIGH OUTPUT:** Connect the HIGH OUT to the input of the high frequency (tweeter) amp.
- ⑦ **2-WAY / 3-WAY switches:** Converts each channels outputs from 3-Way to 2-Way. *For Mono 4-or 5-Way, slide these switches to the 3-WAY position.*
- ⑧ **MONO-STEREO switch:** Push this to the MONO *in* position.
- ⑨ **POWER input connector:** *Use only a model RS 1 or other power supply approved by Rane.* This unit is supplied with a remote power supply suitable for connection to this input jack.
- ⑩ **Chassis ground point:** A #6-32 screw is used for chassis grounding purposes. Always connect the crossover chassis to the amplifier chassis. See 'Chassis Grounding' on page Manual-3 for details.



## REAR PANEL: ALTERNATE MONO 4-WAY INSTALLATION

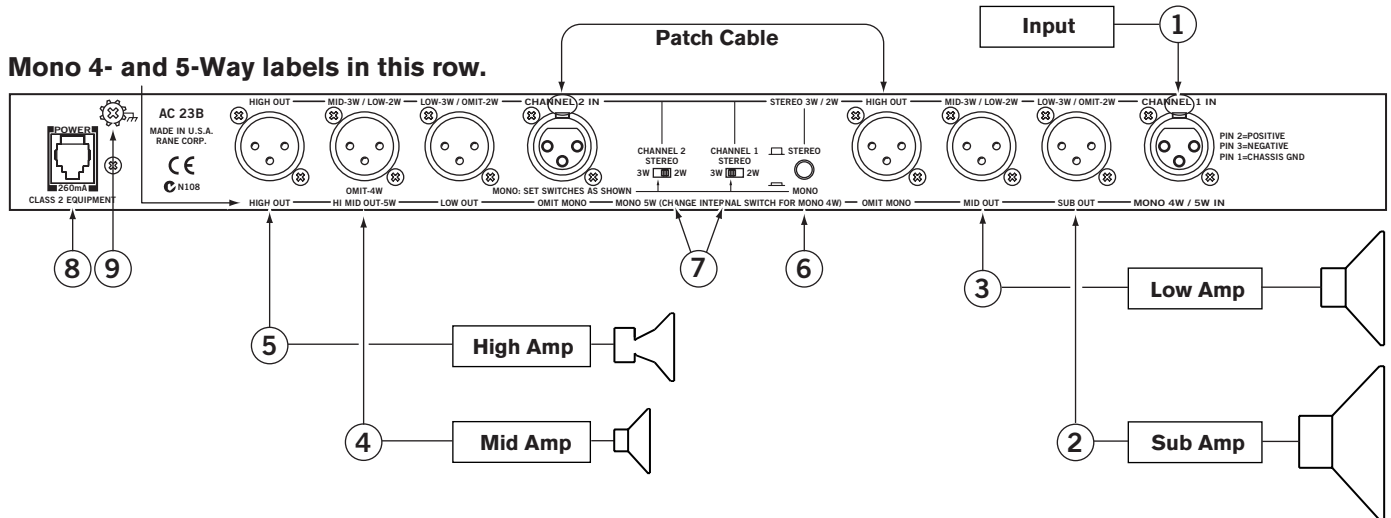

**Note: The switching in the AC 23B will result in a Mono 4-Way configuration with the crossover ranges SUB, LOW, MID & HIGH from left to right across the bottom front panel. By connecting a patch cable from the CHANNEL 1 HIGH OUT to the CHANNEL 2 INPUT, the LOW / MID crossover range changes from 70 Hz-1 kHz to a higher range of 190 Hz-7 kHz. Switch CHANNEL 1 to 3-Way, and CHANNEL 2 to 2-Way. Note: DO NOT follow the Mono 4-Way Switch Instructions on page Manual-7, it must be set to 5-Way.**

- ① **MONO INPUT:** Connect the output from your mixer or other signal source only to the CHANNEL 1 INPUT; do not use the Channel 2 Input. *Note: For this alternate Mono 4-Way installation, connect a patch cord from the CHANNEL 1 HIGH OUT to the CHANNEL 2 INPUT as shown.*
- ② **SUBWOOFER OUTPUT:** Connect the SUB OUT to the input of the subwoofer amplifier (or bass bin amp).
- ③ **LOW OUTPUT:** Connect the MID OUT to the input of the low frequency amplifier.
- ④ **MID OUTPUT:** Connect the HIGH-MID OUT to the input of the mid frequency amplifier. *Be sure the CHANNEL 1 HIGH LEVEL and the CHANNEL 2 MASTER LEVEL controls are set at "7" for unity gain between Channels.*
- ⑤ **HIGH OUTPUT:** Connect the HIGH OUT to the input of the high frequency amplifier.
- ⑥ **STEREO-MONO switch:** Be sure this switch is in the STEREO *out* position. Yes, STEREO. A Mono circuit is created when Channel 1 is patched into Channel 2, and the correct signal flow depends on this switch.
- ⑦ **2-WAY / 3-WAY switches:** Converts each channels outputs from 3-Way to 2-Way. *For this configuration, set CHANNEL 1 to 3-Way, and CHANNEL 2 to 2-Way.*
- ⑧ **POWER input connector.** Use only a model RS 1 or other power supply approved by Rane. This unit is supplied with a remote power supply suitable for connection to this input jack.
- ⑨ **Chassis ground point.** A #6-32 screw is used for chassis grounding purposes. Always connect the crossover chassis to the amplifier chassis. See 'Chassis Grounding' on page Manual-3 for details.

## OPERATING INSTRUCTIONS

### Selecting Crossover Frequencies

Most speaker manufacturers supply low and/or high frequency cut-off points for each driver, especially if these are supplied in a system. These cut-off frequencies are based on each driver's performance at and beyond this point, with a certain safety margin to accommodate more gentle filter roll-offs and resultant higher output beyond the recommended performance range.

The AC 23B utilizes 41-detent crossover frequency selectors which are precision potentiometers. The detents will assure consistent accuracy from Channel to Channel and unit to unit. This is a distinct advantage over the continuously variable designs with low-tolerance parts, possible knob misalignment and panel screening variations. Even with 41 choices it is possible that the exact recommended crossover frequency may not fall on one of the detents on the selector. Not to panic, for these sound reasons:

1. The AC 23B possesses 24 dB/octave roll-off, so the crossover points may be set to the nearest detent above or below the recommended limit with virtually no hazard to the driver or degradation in sound quality. If extremely high power levels are expected, it is safer to defer to the high frequency drivers and shift the crossover point *up* in frequency rather than down.
2. Detents do not rely on knob alignment, silk-screen accuracy, parallax and other variables which erode the accuracy of continuously variable designs. Chances are that even careful visual alignment on these will often yield a frequency error greater than a full detent on the AC 23B.
3. If it is absolutely critical to obtain the exact crossover frequency (Mil Spec., P.A., etc.), the selector *can be positioned between detents* if necessary. This of course will require the aid of a precision signal generator and other equipment to verify the exact setting.

For best overall system results, try to choose the speaker components so that each operates well within its recommended limits. This will provide valuable leeway so that you may move crossover points in order to fine-tune the system, and will also yield higher system reliability. If at all possible, beg, borrow or best yet always use some kind of realtime analyzer to tune your crossover and fine-tune the system for each different location with an equalizer. Refer to the following pages for further alignment details.

## Time Delay Adjustment Procedure

Before jumping feet first into the realm of time delay and how to adjust it, it might help to spend a moment here to re-affirm why on earth this delay is really necessary. For a short course on time delay, Linkwitz-Riley and other mouth-watering details, we urge you to read the "Linkwitz-Riley Crossovers" RaneNote from Rane's web site.

Problems pop up when two different speakers emit the same frequency as occurs in the crossover regions of two, three, four and five way systems. Because the two drivers are displaced vertically, cancellation occurs somewhere off-axis because the sound waves have to travel different distances from the two speakers and hence, will arrive out of phase. This forms a "lobe" or radiation pattern, bounded on either side by cancellation lines or axes, which narrow the dispersion pattern or listening area of the speaker.

Fine. So we put up with it. But to make matters worse, when the two drivers are horizontally displaced – that is, one is in the front of or behind the other, this "lobe" or dispersion pattern gets *tilted* (usually upward) toward the driver that is further behind. This gets hard to put up with, because the end result is that your speaker system will have two, three, four or more tilted radiation patterns and only two or three people in the house will have decent seats. And we're not talking trivial pursuits here—this rampant lobing error can make a sound system a real headache to listener and operator alike.

The idea, then, is to be sure that all drivers are vertically aligned and that all components are always in phase. Then all the main lobes are on-axis, well behaved, and the system enjoys the widest possible dispersion pattern so that everyone gets good sound. The one catch is that in many cases it is physically or otherwise impossible to get all the drivers vertically lined up at the sound source. *This* is where time delay comes in.

By electronically delaying the signal going to the front driver, enough time allows the sound from the rear driver to literally catch up to the forward driver's voice coil, so that signal from both drivers is emitted in phase—and it works! Time delay makes an appreciable improvement in overall sound. The trick is finding the proper time delay amount: hence the rest of this section.

Unfortunately the amount of time delay is a function of *two* factors (life ceased to be simple after age 9, right?): the amount of horizontal displacement between driver voice coils, *and* the actual crossover frequency involved. Setting delay controls by ear is supposedly possible, but *very* tricky and unreliable. The following methods are a couple of (but by no means all) means of setting time delay.

## Time Delay Adjustment Using Realtime Analyzer & Pink Noise

This method outlines the use of a realtime analyzer, pink noise generator and flat response microphone to set crossover time delay. Some references will be made to the Rane RA 30 realtime analyzer for those with the intelligence and good taste to use one of these regularly. The procedure applies to virtually any analyzer system. We recommend using a 1/3 or 2/3 octave analyzer as either of these is more likely to match your specific crossover points than a one-octave analyzer. And it *is* important to match the analyzer to the crossover point as closely as possible for proper phase alignment, otherwise the analyzer readings may be misleading.

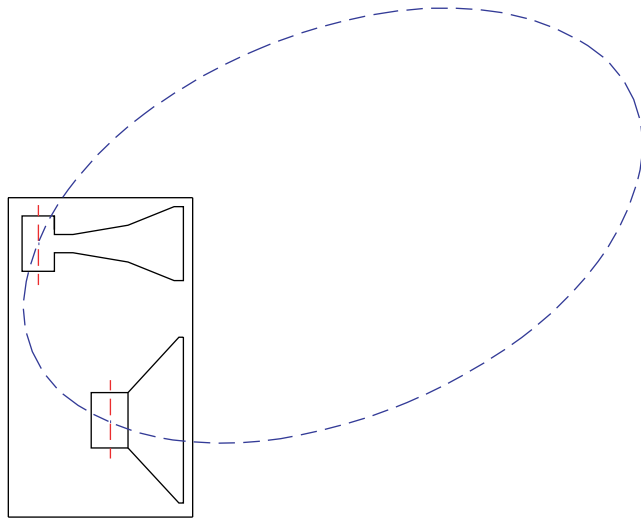

Fig. 1 In-Phase Axis Response Without Time Delay

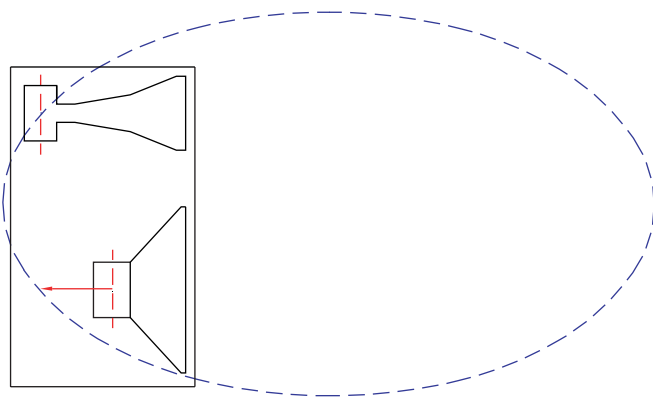

Fig. 2 Corrected In-Phase Axis Response With Electronic Time Delay on Low Frequency Driver

## STEP BY STEP PROCEDURE

A 3-Way mode consisting of High, Mid and Low drivers is used here as an example. For other configurations, use the same procedure starting with the highest crossover point and repeating steps 2 through 5 for each lower crossover point. *NOTE: If you are running two separate channels on the crossover, tune up only **one** channel at a time, using the same procedure for both.*

1. Place the analyzer microphone about 15 feet in front of the speaker stack and at a height about midway between the high and mid drivers. Turn all crossover LEVEL controls fully down.
2. Connect the pink noise source to the INPUT of the crossover (or mixer or wherever is convenient). Turn up the crossover MASTER LEVEL control and the MID OUT control until noise is heard *only* from the mid driver at a comfortable volume.
3. With a healthy but not uncomfortable volume of noise from the mid driver, set the analyzer DISPLAY LEVEL control so the LED's corresponding to the high crossover frequency are reading 0 dB (this would be a green LED at the crossover frequency with any of the Rane analyzers). For example, if your high crossover frequency is 2 kHz, set the RA 30 in the  $\pm 1$  dB mode and then adjust the RTA LEVEL control until the green LED is lit in the 2 kHz band. There...easy.
4. Now press in the MID MUTE switch on the crossover so that the tone is removed from the mid driver. *Without re-adjusting either the meter or the crossover Input or Mid Level controls*, turn up the HIGH LEVEL control until the tone coming from only the high driver reads 0 dB (a green LED at the crossover frequency).
5. Now release the MID MUTE switch on the crossover so that pink noise is heard from *both* the high and mid drivers. Switch the display sensitivity to  $\pm 3$  dB on Rane analyzers (not necessary with full scale analyzers) and observe the display reading at the crossover frequency:
  - i. If the display shows a +3 dB reading, then the drivers are properly phase aligned and no delay is necessary; leave the MID DELAY control at minimum.
  - ii. If the display shows *less* than +3 dB reading, slowly turn up the MID DELAY control on the crossover until the display shows +3 dB. Now the drivers are electronically phase aligned. The Delay control should be left in this position unless the speaker system is physically altered.
  - iii. If the MID DELAY control is all the way up and you still do not have a +3 dB (red) reading, you will have to physically move the high driver farther *forward* until the display shows +3 dB (red). The amount of displacement correction available from the Delay depends on the actual crossover frequency: the higher the frequency, the

less amount of correction capability. If the drivers are built into a single cabinet and/or it is impossible to change relative positions, then you will have to obtain additional external delay to achieve proper phase alignment. The Rane AD 22B would be suitable.

- iv. If turning the MID DELAY control *up* makes the display reading *decrease* instead of increase, this means that the high driver is actually in *front* of the mid driver; adding delay to the mid driver only worsens the situation. There are a couple of ways to deal with this:
    - a. Try to move the high driver back as far as possible without losing stability in balancing the speaker stack. You may want to raise it up as well to restore dispersion close to the stack. If you cannot move the high driver, then you will have to use an additional delay source to align the high and mid drivers. The built-in delay system in the AC 23B is designed to accommodate the majority of common speaker configurations; if you encounter confusion or difficulty with your particular system, it is best to consult your dealer or the Rane factory for assistance.
    - b. If this decrease in the display due to the DELAY control occurs at a low frequency crossover point below about 150 Hz, set the DELAY control to minimum and leave it there. Frequencies below 150 Hz are actually omnidirectional, so that phase misalignment is virtually inaudible below this point. Subwoofers will often possess long folded or straight horns, resulting in the diaphragm being well behind the rest of the stack. Most authorities agree that phase alignment of subwoofers is unnecessary.
6. Lower the microphone until it is vertically midway between the mid and low drivers. Repeat steps 2 through 5, using the crossover LEVEL control, MUTE switch and next DELAY control. You may start each series of steps 2 through 5 at a different volume as necessary—but once the Levels are set in step 3 do not alter these until step 5 is completed. Once all of the crossover DELAY controls are set, then adjust the output LEVEL controls as outlined on page Manual-15.

## Time Delay Adjustment Using SPL Meter & Tone Generator

Now that good quality realtime analyzers are becoming more affordable and easier to use, there are few reasons why one of these should not be regularly used in any sound system. If an analyzer is simply not available or for some reason inappropriate, an accurate delay setting can be obtained by using a straightforward SPL meter (obtainable at most local electronics stores, the best is the Rane RA 30) and some kind of variable tone generator.

In order to exclude the effect of room acoustics and imperfect driver response, only the crossover frequencies are to be emitted (one at a time) by the tone generator. First the highest crossover frequency is run through the crossover and each of the two speakers sharing the crossover point is set *separately* to an arbitrary 0 dB level on the SPL meter. When both drivers emit the crossover tone simultaneously, the combined response should read +3 dB higher on the meter. If the drivers are not phase aligned, some cancellation will occur on-axis, resulting in a combined response *less* than +3 dB. Turning the delay control up causes the lower frequency driver to electronically move backward until the SPL meter reads +3 dB; then the two drivers are electronically aligned and the on-axis cancellation is eliminated. This procedure is then repeated for the next lower crossover point(s).

## STEP BY STEP PROCEDURE

A 3-Way mode consisting of high, mid and low drivers is used here as an example. For other configurations, use the same procedure starting with the highest crossover point and repeating steps 2 through 5 for each lower crossover point.

1. Set the tone generator to the highest crossover frequency and plug it into the INPUT of the crossover. Turn all crossover LEVEL controls fully down.
2. Position the SPL meter (microphone) about 15 feet in front of the speakers and at a height about midway between the high and mid drivers. It is very important that the meter remain in exactly the same position throughout the test, so affix it to a mic stand, small tree or other stable object. Set the switches on the SPL meter to “C-weighting”, “Slow” if available. Be sure to minimize background noise (air conditioners, fans, traffic, wild animals, etc.) as these will effect the meter reading.
3. Slowly turn up both the crossover MASTER LEVEL control and the MID LEVEL control until the tone is heard through the mid driver. Adjust the SPL meter control and/or the crossover LEVEL controls until you obtain a 0 dB reading on the meter. Verify that no sound is coming from any other speakers except the mid driver.
4. Now press in the MID MUTE switch on the crossover so that the tone is removed from the mid driver. *Without re-adjusting either the meter or the crossover Input or Mid frequency Level controls*, turn up the HIGH LEVEL control until the tone coming from only the high driver reads 0 dB on the SPL meter.
5. Now release the MID MUTE switch so that the tone is emitted from *both* the high and mid drivers. Check the reading on the SPL meter:
  - i. If the meter reads +3 dB, then the drivers are properly phase aligned and no delay is necessary; leave the MID DELAY control at full minimum.
  - ii. If the meter reads *less* than +3 dB, slowly turn up the MID DELAY control until the meter just reads +3 dB. Now the drivers are electronically phase aligned and the delay control should be left in this position at all times, unless the speaker system is physically altered.
  - iii. If you have turned the MID DELAY control all the way up and still do not obtain a +3 dB reading, you will have to physically move the high driver farther forward until the SPL meter reads +3 dB. The amount of displacement corrections available from the delay depends on the actual crossover frequency: the higher the frequency the less amount of correction capability. If the drivers are built into a single cabinet and/or it is impossible to change relative positions, then you will have to obtain additional delay to achieve proper phase alignment.
- iv. If turning the MID DELAY control up makes the SPL reading *decrease* instead of increase, this means that the high driver is actually in *front* of the mid driver; adding delay to the mid driver then only worsens the situation. There are a couple of ways to deal with this:
  - a. Try to move the high driver back as far as possible without losing stability in balancing the speaker stack. You may want to raise it up as well to restore dispersion close to the stack. If you cannot move the high driver, then you will have to obtain an additional external delay source to align the high and mid drivers. The built-in delay system in the AC 23B is designed to accommodate the majority of common speaker configurations; if you encounter confusion or difficulty with your particular system, it is best to consult your dealer or the Rane factory for assistance.
  - b. If this decrease in the display due to the LOW DELAY control occurs at a low frequency crossover point below about 150 Hz, set the LOW DELAY control to minimum and leave it there. Frequencies below 150 Hz are actually omnidirectional, so that phase misalignment is virtually inaudible below this point. Subwoofers will often possess long folded or straight horns, resulting in the diaphragm being well behind the rest of the stack. Most authorities agree that phase alignment of subwoofers is unnecessary. Otherwise you will have to obtain additional delay equipment to align these to the rest of the system.
6. Tune the tone generator to the next lower crossover frequency and then repeat steps 2 through 5, using the appropriate level and delay controls. Once the DELAY control is set, you may re-adjust any of the crossover LEVEL controls at the beginning of each alignment procedure. Once all of the crossover DELAY controls are set, then re-adjust the output LEVEL controls as outlined on page Manual-15.



## Delay vs. Frequency Table

If you do not have the equipment necessary to electronically align the system as described in previous sections, you may use the table below to obtain a *rough and approximate* phase alignment of your drivers. Measure the horizontal displacement between the voice coils of the two adjacent drivers sharing the same crossover point, then find the column in the table nearest your actual displacement. Move down this column to the proper crossover frequency as indicated on the left of the table: the corresponding delay knob setting will then be the closest for your system. For example, if you have a two-way system crossed over at 800 Hz with the compression driver voice coil located about 9" behind the woofer voice coil, the delay knob setting corresponding to a 9" displacement at 800 Hz on the table would be "5" as indicated on the front panel.

In order to phase-align two drivers you must observe only the crossover frequency, which is common to both drivers. Pink noise can be used if all other frequencies are disregarded, since room acoustics and imperfect driver response will cause erroneous alignment attempts. Using pink noise as a source, each driver is individually tuned to an arbitrary 0 dB level on the analyzer display *only at the crossover frequency*. When both are turned on simultaneously, the combined response of the two drivers should read +3 dB higher at the crossover frequency on the display. If the drivers are not phase-aligned, some cancellation will occur on-axis, resulting in a combined response less than +3 dB. Turning up the DELAY control causes the lower driver to electronically move backward until the analyzer reads +3 dB; then the two drivers are electronically aligned and the on-axis cancellation is eliminated.

### Voice Coil Displacement (Inches)

Crossover Frequency (Hz)	Voice Coil Displacement (Inches)									
	.75"	1.5"	3"	6"	9"	12"	15"	18"	21"	24"
70	1	1.5	2	2.5	3.5	5	6	7	8	MAX
80	1	1.5	2	2.5	3.5	5	6	7	8	MAX
100	1	1.5	2	2.5	3.5	5	6	7	8	MAX
150	1	1.5	2	2.5	3.5	5	6	7	MAX	
200	1	1.5	2	2.5	3.5	5	6	7	MAX	
250	1	1.5	2	2.5	3.5	5	7	8	MAX	
300	1	1.5	2	2.5	3.5	5.5	7	MAX		
400	1	1.5	2	2.5	4	6	8	MAX		
450	1	1.5	2	2.5	4	6	8	MAX		
500	1	1.5	2	2.5	4	6	8	MAX		
800	1	1.5	2	3	5	7	MAX			
1k	1	1.5	2.2	3	6	MAX				
1.2k	1	1.5	2.2	3.5	MAX					
1.5k	1	1.5	2.3	3.5	MAX					
2k	1	1.5	2.3	MAX						
2.5k	1	1.5	2.3	MAX						
3k	1	1.7	2.4	MAX						
3.6k	1	1.7	MAX							
4k	1	1.8	MAX							
6k	1	2	MAX							
7k	1.2	MAX								

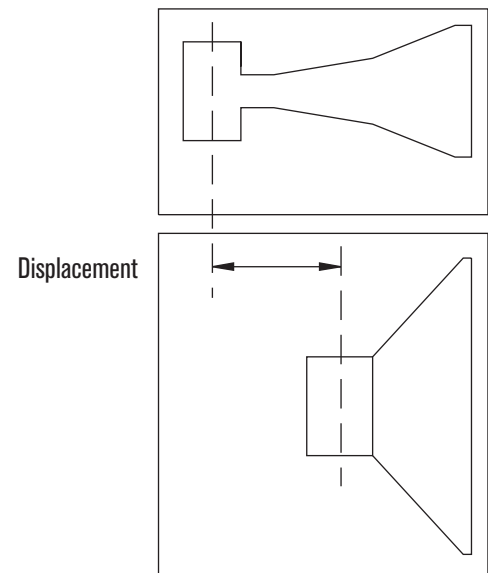

Figure 3. Front-to-Back Displacement Distance

## Setting the Output Level Controls

Choosing the crossover frequencies was the easy part. Now it gets real fun. The idea is to set the output Level controls on the crossover so that the entire speaker system has a uniform, flat response. Unfortunately, the *room* in which the speakers are placed has a habit of always getting into the act, so things get messy. As a result there seems to be two schools of thought regarding the use of active crossovers.

### The Set-It-Once-And-Glue-It School

The philosophy here is to use the crossover to flatten system response as much as possible *without* room acoustics involved. This means setting up the system outside (unless you happen to have a *very* large anechoic chamber handy) and with the aid of a realtime analyzer and pink noise source (ala RA 30), adjust all of the crossover outputs so that the system is as flat as possible. Once the system is tuned, the crossover is then locked behind a security cover (posted guard is optional) and never again touched. It is then the job of the system *equalizer(s)* to normalize or flatten the system to each different room.

### The Fix-It-With-The-Crossover School

Here the crossover knobs get a good workout, for the crossover is used at each location to help flatten the system along with the equalizer. Some even maintain that a good active crossover can work alone like a parametric equalizer in the hands of an expert. This does require experience, skill, and the right equipment to back it up (not to mention a licensed set of ears).

Regardless of which school you profess, the absolute importance and effectiveness of some kind of realtime analyzer in your system cannot be overstressed! No, this is not a callous plug for our other products; analyzers in general have come a long way. They're out of the lab (i.e. closet) and into the hands of every smart working musician and sound technician. An analyzer will save tremendous amounts of time and provide the absolute consistency, accuracy, and plain old good sound that very few ears on this earth can deliver. They are affordable, easy to use and amazingly effective. You owe it to yourself and your audience to at least look into one of these analyzers — you'll wonder how you managed at all without one.

Whether by analyzer or ear, here are a few recommended methods of setting the crossover output Levels.

## Setting Levels Using a Realtime Analyzer

*NOTE: If you are running two Channels, tune up only one Channel at a time.*

1. Set all LEVEL controls on the crossover to minimum; leave Delay and Frequency controls as set previously.
2. Place the analyzer microphone at least 15 feet away from the speaker stack, on axis (dead ahead) and about chest level. Minimize any background noise (fans, air conditioners, traffic, etc.) that could affect the readings.
3. Run pink noise through the system, either through a mixer channel or directly into the crossover. Turn all amplifier controls at least half way up.
4. We will use the 3-Way mode here as an example—the procedure applies to all configurations. Turn up the INPUT LEVEL control(s) on the crossover about half way.
5. Slowly turn up the LOW LEVEL control on the crossover, until you hear a healthy level of noise through the low frequency drivers (it should sound like rumble at this point).
6. Adjust the display controls on the analyzer so that it shows the greatest number of 0 dB LED's (green on Rane equipment) below the crossover point.
7. Now slowly turn up the MID LEVEL on the crossover until the display shows the same output level average as the Low frequency section.
8. Repeat this procedure for all crossover frequency sections, lowest to highest, so that the end result is as flat response as possible on the analyzer display.

*IMPORTANT: Compression driver or horn roll-off, bass roll-off, and room acoustics usually cannot be corrected by the crossover. If you are using constant directivity horns, see page 18. If, for example, you are adjusting the High frequency controls and observe a decline in frequency response somewhat above the crossover point, then set the crossover LEVEL control for equal display level near the crossover point and leave it there. Then use an equalizer or bank of tweeters to correct the roll-off problem. If you are tuning the system in a room, the room acoustics will greatly influence the system response, as shown by the analyzer.*

Check the system response on an analyzer at several other locations and adjust the crossover as necessary to reach a fixed compromise setting if desired. If you plan to use the analyzer only once to set the crossover, set up the speaker system in a quiet place *outside* or in a very large concert theater, and run pink noise at low levels with closer microphone placement to keep the room acoustics out of the picture as much as possible.



## Setting Levels Using an SPL Meter & Pink Noise Generator

The MUTE switches on the AC 23B make using an SPL meter an easy and relatively accurate means of tuning a system. The Rane RA 30 has everything you need, an SPL meter and a pink noise source. If you can't get one of those right now, obtain a good SPL meter and a pink noise generator from a local electronics store. You may also use a sweep or tone generator in place of a pink noise source. If so, be sure to look at several different tones within each crossover section to get a good average driver response.

1. Run pink noise into the crossover Inputs (through the mixer or directly, as is convenient).
2. Make sure all crossover output LEVEL controls are turned all the way down and all amplifier level controls are at least half way up to start with.
3. Turn the crossover MASTER LEVEL(s) half way up. Place the SPL meter at least 15 feet from the speaker stack and about chest high. Once positioned, make sure that the SPL meter remains in the *exact* same location for the rest of the procedure. Minimize all background noise (fans, air conditioners, traffic, wild animals, etc.) to get accurate readings. Set the SPL meter to "C-weighting" "Slow" if switches are present.
4. Slowly turn the LOW LEVEL of the crossover up until there is a healthy rumble coming from the bass speakers (For this example the 3-Way configuration is used—the same procedure applies to all configurations, starting with the lowest frequency and ending with the highest). Adjust the SPL meter and/or crossover output until you get a 0 dB reading on the meter. *After this point do not change the controls on the SPL meter.*
5. While leaving the LOW LEVEL control at the 0dB adjustment just obtained, press the LOW MUTE switch on the crossover so that the pink noise disappears from the bass speakers (revel in the silence...).
6. Now slowly turn up the MID LEVEL control so pink noise is heard from the mid frequency speakers. Without changing any settings on the SPL meter, adjust the MID LEVEL until you obtain a 0 dB reading on the SPL meter. Now the low and mid speakers are set at the same level.
7. Now press the MID MUTE switch on the crossover so that the pink noise again disappears.
8. Repeat this process for each frequency section of the crossover, ending with the highest frequency. *NOTE: It is possible that you may turn one of the frequency section output LEVEL controls all the way up and still not have enough volume for a 0 dB reading (as determined by previous section levels). This is probably due to different sensitivities of amps, speakers and other level controls in the system. When this happens, re-set the SPL meter so that it reads 0 dB on this frequency section (you may have to "down range" the meter and re-adjust the crossover level control). Now go back and re-adjust the previous crossover level controls, turning these down to get a 0 dB reading on the meter.*

9. Once the HIGH LEVEL control is set for 0 dB on the meter, disengage all of the MUTE switches on the crossover, and check that noise is emitting from all the speaker components. The crossover should now be aligned. Make any overall level adjustments with the MASTER LEVEL controls and leave the output level controls unchanged.

## Constant Directivity Horn EQ Mod

Constant Directivity (or CD) horns need additional equalization to help cover the same area a long throw horn can cover. Additional circuitry has been added to the AC 23B for additional equalization of the High Frequency outputs for the CD Horns. *This modification should only be attempted by an experienced technician.*

It is important to know the 3 dB down point of the CD driver's frequency response. The manufacturer of your driver should be able to supply you with a frequency response curve. Find the point where the high end *starts* to roll off, and look for the point on the chart that is 3 dB down from *that* point (toward the right, as the higher frequencies roll off). Find the frequency at the bottom of the chart of this point—an approximate is fine, you don't have to be exact. Find the closest frequency in the table below to determine the correct value capacitor to install in the AC 23B to correct for this high frequency roll off.

### STEP BY STEP PROCEDURE

This procedure is for CD horn EQ on the High output in Stereo 3-Way mode. For a Mono 4- or 5-Way system with a CD horn on the high output, only place C16 in Channel 2.

1. Remove the top and bottom covers of the AC 23B.
2. Locate the positions for C15 and C16 on the Schematics page 3 and on the circuit board. See Assembly Diagram.
3. Clean the solder pad on the underside of the board so that the appropriate capacitor can be inserted. Install the capacitor, and solder the leads from the underside using fresh solder. Clip the excess leads.
4. Replace the top and bottom covers.

3 dB Down Frequency	Capacitor
2.0 kHz	.0068 $\mu$ f
2.5 kHz	.0056 $\mu$ f
3.0 kHz	.0047 $\mu$ f
3.7 kHz	.0039 $\mu$ f
4.0 kHz	.0036 $\mu$ f
5.0 kHz	.0030 $\mu$ f
6.0 kHz	.0024 $\mu$ f