

NX

Oil Burner Manual

Beckett™

RESIDENTIAL BURNERS



WARNING

Potential for Fire, Smoke and Asphyxiation Hazards



Incorrect installation, adjustment, or misuse of this burner could result in death, severe personal injury, or substantial property damage.

To the Homeowner or Equipment Owner:

- Please read and carefully follow all instructions provided in this manual regarding your responsibilities in caring for your heating equipment.
- Contact a professional, qualified service agency for installation, start-up or service work.
- Save this manual for future reference.

To the Professional, Qualified Installer or Service Agency:

- Please read and carefully follow all instructions provided in this manual before installing, starting, or servicing this burner or heating system.
- The Installation must be made in accordance with all state and local codes having jurisdiction.

Table of Contents

General Information
Hazard Definitions 4

Information To Be Used Only By Qualified Service Technicians

General Information 4
Notice Special Requirements 5
General Specifications 5

Inspect/Prepare Installation Site 6
Inspect Chimney or Direct Vent System 6
Combustion Air Supply 7
Direct Air Supply & Sidewall Venting 7

Prepare the Burner 8
General 8
Low Fire Rate Baffle (if specified) 8
Mount Burner on Appliance 8
Connect Fuel Lines 9
Fuel Line Installation 9
Fuel Line Valves and Filters 9
Fuel Supply Level with or Above Burner 9
Fuel Line Below Level of Burner 10
Fuel Line Installation 10

Wire Burner 10
Wiring Connection Diagram 11
GeniSys Model 7505 Control 12
Typical Burner Sequence of Operation 12

Start the Burner and Set Combustion 15
Start-up and Initial Settings 15
Set Combustion with Test Instruments 17
Cover Installation 17

Trained Service Technician’s Regular Maintenance 18
Removing Nozzle Line for Service 19
Nozzle Installation 19
Check/Adjust Electrodes 20
Check Retention Head Alignment and Cad Cell Sighting 20
Check/Adjust “Zero” Calibration 21
Blower Wheel Replacement 21

Replacement Parts Diagram 22
Replacement Parts Diagram 22
Replacement Parts List 23

Beckett Limited Warranty Information 24

General Information

Hazard Definitions

DANGER Indicates a hazardous situation, which, if not avoided, will result in death or serious injury.

WARNING Indicates a hazardous situation, which, if not avoided, could result in death or serious injury.

CAUTION Indicates a hazardous situation, which, if not avoided, could result in minor or moderate injury.

Within the boundaries of the hazard warning, there will be information presented describing consequences if the warning is not heeded and instructions on how to avoid the hazard.

NOTICE Intended to bring special attention to information, but not related to personal injury or property damage.

General Information

WARNING Owner's Responsibility



Incorrect installation, adjustment, and use of this burner could result in severe personal injury, death, or substantial property damage from fire, carbon monoxide poisoning, soot or explosion.

Contact a professional, qualified service agency for the installation, adjustment and service of your oil heating system. This work requires technical training, trade experience, licensing or certification in some states and the proper use of special combustion test instruments.

Please carefully read and comply with the following instructions:

- Never store or use gasoline or other flammable liquids or vapors near this burner or appliance.
- Never attempt to burn garbage or refuse in this appliance.
- Never attempt to light the burner/appliance by throwing burning material into the appliance.
- Never attempt to burn any fuel not specified and approved for use in this burner.
- Never restrict the air inlet openings to the burner or the combustion air ventilation openings in the room.

CAUTION Frozen Plumbing and Water Damage Hazard

If the residence is unattended in severely cold weather, burner primary control safety lockout, heating system component failures, power outages or other electrical system failures could result in frozen plumbing and water damage in a matter of hours. For protection, take preventive actions such as having a security system installed that operates during power outages, senses low temperature and initiates an effective action. Consult with your heating contractor or a home security agency.

Figure 1. Burner label location

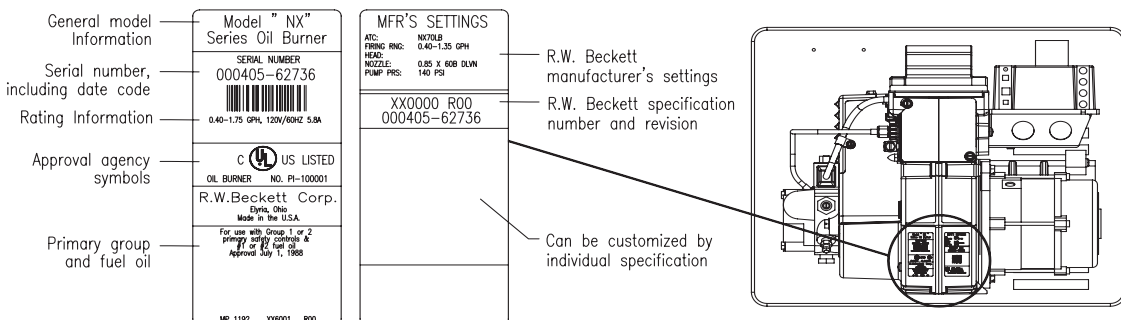

SK9675

To the Owner:

Thank you for purchasing a Beckett burner for use with your heating appliance. Please pay attention to the Safety Warnings contained within this instruction manual. **READ THIS MANUAL AND SAVE FOR YOUR RECORDS.** Provide it to your qualified service agency for use in professionally setting up and maintaining your oil burner.

Your Beckett burner will provide years of efficient operation if it is professionally installed and maintained by a qualified service technician. If at any time the burner does not appear to be operating properly, **immediately contact your qualified service agency** for consultation.

We recommend annual inspection/service of your oil heating system by a qualified service agency.

Daily – Check the room in which your burner/appliance is installed. Make sure:

- Air ventilation openings are clean and unobstructed
- Nothing is blocking burner inlet air openings
- No combustible materials are stored near the heating appliance
- There are no signs of oil or water leaking around the burner or appliance

Weekly

- Check your oil tank level. Always keep your oil tank full, especially during the summer, in order to prevent condensation of moisture on the inside surface of the tank.

• Notice Special Requirements

- THE INSTALLATION OF A BURNER SHALL BE IN ACCORDANCE WITH THE REGULATIONS OF AUTHORITIES HAVING JURISDICTION.
- For recommended installation practices in the U.S. refer to the latest edition of NFPA 31. (CSA-B139 and CSA-B140 in Canada.
- Concealed damage — If you discover damage to the burner or controls during unpacking, notify the carrier at once and file the appropriate claim.
- When contacting Beckett for service information — Please record the burner serial number (and have available when calling or writing). You will find the serial number on the silver label located on the left rear of the burner. Refer to Figure 1.

⚠ WARNING Impaired Burner Performance and Fire Hazard.

Do NOT operate the burner beyond specifications outlined in the following Table.

- For applications beyond these limits, consult Beckett Technical Service at 1-800-645-2876.
- NOTE: Some packaged appliances with burners may be agency listed as a unit to operate beyond these limits. Consult the appliance manufacturer's specifications and agency approvals for verification.

General Specifications

Table 1 – Burner Specifications

Capacity (Note 1)	Firing rate: - 0.40 – 1.75 GPH Input: Min. - 56,000 Btu Max - 245,000 Btu
Certification/ Approvals	UL certified to comply with ANSI/UL296 & tested to CSA B140.0
Fuels	U. S: No. 1 or No. 2 heating oil only (ASTM D396) Canada: No. 1 stove oil or No. 2 furnace oil only  DO NOT USE GASOLINE, CRANKCASE OIL OR ANY OIL CONTAINING GASOLINE.
Electrical	Power supply - 120 volts AC, 60 Hz, single phase Operating load - 5.8 Amps max Motor - 1/7 hp, 3450 rpm, NEMA 48M frame PSC rotation CCW when facing shaft end Ignition - Continuous duty solid-state igniter
Fuel pump	Outlet pressure - Note 2
Air tube	ATC code - See Table 2
Dimensions (with cover)	Height (maximum) - 12-1/2 inches Width (maximum) - 15 inches Depth - 9-1/4 inches Air tube diameter - 3-1/4 inches
Ambient Operating Temperature	+32° F. (0 C.) Minimum +115° F. (+46 C.) Maximum (See above Warning)
Moisture	5% to 95% RH, non-condensing and non-crystallizing

Note 1: Approval agency listed rating for these burners is 0.40 to 1.75 gph. However, the firing rate range is limited by the specific air tube combination being used. Refer to Table 2.

Note 2. See appliance manufacturer's burner specifications for recommended pump discharge pressure.

Table 2 – Air Tube Combinations (ATC)

Firing rate (gph)	Head	ATC codes for usable air tube lengths:		
		5"	7"	9"
(min-max)				
0.40-1.00	9-Slot	NX50LG	NX70LG	NX90LG
0.40-1.00	6-Slot	NX50LH	NX50LH	NX90LH
0.40-1.35	9-Slot	NX50LB	NX70LB	NX90LB
0.40-1.35	6-Slot	NX50LC	NX70LC	NX90LC
1.10-1.75	9-Slot	NX50LD	NX70LD	NX90LD
1.10-1.75	6-Slot	NX50LF	NX70LF	NX90LF

Inspect/Prepare Installation Site

Inspect/Prepare Installation Site

WARNING Professional Service Required

 **Incorrect installation, adjustment, and use of this burner could result in severe personal injury, death, or substantial property damage from fire, carbon monoxide poisoning, soot or explosion.**

Please read and understand the manual supplied with this equipment. This equipment must be installed, adjusted and put into operation only by a qualified individual or service agency that is:

- Licensed or certified to install and provide technical service to oil heating systems.
- Experienced with all applicable codes, standards and ordinances.
- Responsible for the correct installation and commissioning of this equipment.
- Skilled in the adjustment of oil burners using combustion test instruments.

The installation must strictly comply with all applicable codes, authorities having jurisdiction and the latest revision of the National Fire Protection Association Standard for the installation of Oil-burning Equipment, NFPA 31 (or CSA B139 and B140 in Canada).

Regulation by these authorities take precedence over the general instructions provided in this installation manual.

• Inspect Chimney or Direct Vent System

WARNING Fire, Smoke & Asphyxiation Hazard

- Carefully inspect the chimney or exhaust vent system.
- Make sure it is properly sized and in good working condition.
- Follow the instructions supplied by the appliance manufacturer.
- The installation must strictly comply with all applicable codes, authorities having jurisdiction and the latest revision of the National Fire Protection Association Standard NFPA 31 for the installation of chimneys and vent sizing, (or CSA-B139 and CSA-B140 in Canada).
- Regulation by these authorities take precedence over the general instructions provided in this installation manual.

Starting with minimum gph firing rate, the minimum size recommended is 6" flue pipe with 8" X 8" inside chimney, unless specified otherwise by the appliance manufacturer.

1. A chimney flue shall extend at least 3 feet above the highest point at which the chimney comes in contact with the roof, and not less than 2 feet above the highest roof surface or structure within 10 feet horizontally of the chimney. Refer to Figure 2.
2. Any accumulation of soot or debris in chimney offsets should be removed
3. Any obstructions such as a protruding joint or a piece of broken tile wedged in the chimney should be removed.
4. No other appliance connection should be made to the same flue pipe.

Figure 2 – Chimney Design - Above the Roof

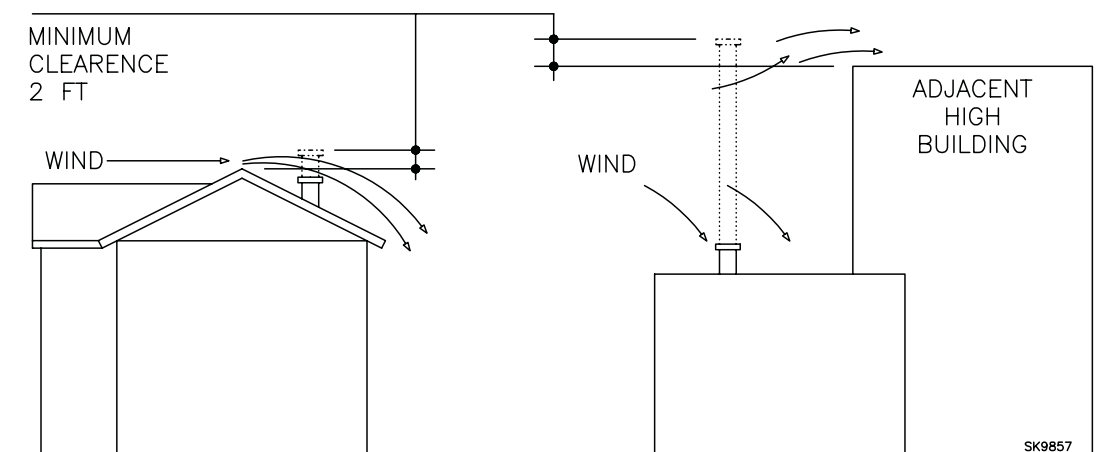

NOTE: Correct chimney design is shown by dotted lines. Incorrect chimney design, as shown by the solid lines, may result in downdrafts.

Inspect/Prepare Installation Site

5. The flue pipe should have an upward pitch toward the chimney of at least 1/4" per foot of length. It should fit tightly and should not project into the chimney.
6. Any leakage between tiles, around clean-out doors, or around the vent pipe should be sealed.

INSULATED STAINLESS STEEL CHIMNEY LINERS

The new designs of high efficiency oil furnaces and boilers in conjunction with flame retention oil burners are more efficient. One result of increased efficiency is lower flue gas temperatures. As flue gases rise in the chimney, they will cool and condense when they reach the dew point. The condensation will mix with the sulphur in the flue gases creating sulphuric acid. The acid will attack the chimney mortar, brick and clay liners causing corrosion, deterioration and blockage of the chimney. Eventually the blockage could prevent exhausting the flue gases. Instead, the flue gases could vent out the barometric damper into the living space.

Therefore, it is strongly recommended that an approved insulated stainless steel liner be installed.

For those installations not requiring a chimney, such as through-the-wall vented appliances, follow the instructions given by the appliance and power venter (if used) manufacturers.

Combustion Air Supply Information

WARNING Adequate Combustion and Ventilation Air Supply Required

Failure to provide adequate air supply could seriously affect the burner performance and result in damage to the equipment, asphyxiation, explosion or fire hazards.

- The burner cannot properly burn the fuel if it is not supplied with a reliable combustion air source.
- Follow the guidelines in the latest editions of the NFPA 31 and CSA-B139 regarding providing adequate air for combustion and ventilation.

Appliances located in confined spaces

All confined spaces should have two (2) permanent openings; one near the top of the enclosure and one near the bottom of the enclosure. Each opening must have a free area of not less than one (1) square inch per 1,000 BTU's per hour of the total input rating of all appliances within the en-

closure. The openings should have free access to the building interior, which should have adequate infiltration from the outside.

Exhaust fans and other air-using devices

Size air openings large enough to supply all air-using devices in addition to the minimum size required for combustion air. If there is any possibility of the equipment room developing a negative pressure due to exhaust fans, clothes dryers, etc., either pipe combustion air directly to the burner or provide a sealed enclosure for the burner and supply it with its own combustion air supply.

Direct Air Supply and Side Wall Venting

WARNING Connect Outside Air Duct to NX Adapter



Failure to install adapter properly could result in impaired combustion, appliance soot-up, puffback of smoke, and fire or asphyxiation hazards.

- The outside air adapter must be installed by strictly following the kit installation instructions.
- DO NOT attempt to install outside air piping without using the outside air adapter and instructions provided.
- Abundant fresh air is required for proper combustion.

For direct vent installations, follow instructions provided with appliance and direct vent system. Outside combustion air is required for direct venting.

When installing an NX outside air adapter (Beckett Part Number 1014U), refer to the instruction sheet supplied with the adapter. This kit allows combustion air to be piped directly to the burner. The NX outside air adapter kit may also be used for chimney vent applications that require outside combustion air.

WARNING Protect Steel Combustion Chamber From Burnout

Failure to comply could result in damage to the heating equipment and result in fire or asphyxiation hazards.

- When retrofitting appliances that have unlined stainless steel combustion chambers, protect the chamber by lining the inside surfaces with a ceramic fiber blanket, such as a wet-pac or other suitable refractory material.
- Some steel chambers may not require liners because the appliance was designed and tested for use with flame retention burners. Refer to the manufacturer's instructions.

Inspect/Prepare Installation Site

- **Clearances to burner and appliance**
 - Provide space around burner and appliance for easy service and maintenance.
 - Check minimum clearances against those shown by the appliance manufacturer and by applicable building codes.
- **Combustion chamber — Burner retrofitting**
Verify that the appliance combustion chamber provides at least the minimum dimensions given in Table 3.

Table 3. Chamber Dimensions

Chamber Dimensions (inches)					
Firing Rate (GPH)	Round I.D.	Rectangular		Height	Floor to nozzle
		Width	Length		
0.50	8	7	8	12	5-6
0.75	9	8	9	12	5-6
1.00	10	9	10	12.5	5-6
1.25	11	10	11	12.5	5-6
1.50	12	11	12	13	6-7
1.75	14	12	15	13.5	6-7

Prepare the Burner

• General

In most cases, the burner is ready to mount to the appliance. There can be situations where the burner needs to be reconfigured to perform properly in the appliance. Review the appliance manufacturer's specifications prior to installing to determine if any modification is required to properly configure the burner.

Instruction on how to perform the following burner preparation tasks can be found in the Professional Maintenance section.

- Remove / install burner nozzle
- Check head/air adjusting plate

• Low Firing Rate Baffle (If specified)

The NX Low Firing Rate Baffle (LFRB), refer to Figure 3, reduces the burner airflow and pressure. Refer to the appliance manufacturer's instructions or the Beckett OEM Specification Guide part number 6711. To avoid poor burner performance, do not omit the baffle when specified or install the baffle when not specified.

NOTICE

The Low Firing Rate Baffle may have been factory installed. If field installation is required, insert the Low Fire Rate Baffle into the housing, aligning the mounting screw hole with the

Figure 3. – Mounting Low Fire Rate Baffle in burner housing.

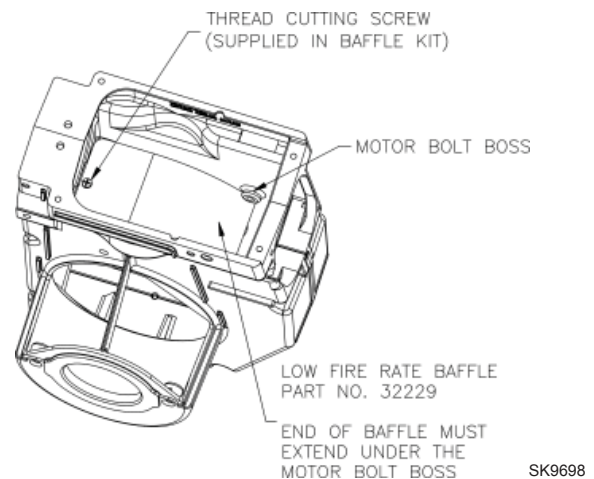

notched hole in the burner housing. Make note that the curved end of the baffle should be below the motor bolt boss. Tighten the thread cutting screw to 12-24 in-lbs.

• Mount Burner on Appliance

Verify that the air tube installed on the burner provides the correct insertion depth. Refer to Figure 4.

The end of the air tube should normally be 1/4" back from the inside wall of the combustion chamber. Never allow the leading edge of the retention ring to extend into the chamber, unless otherwise specified by the appliance manufacturer.

Bolt the burner to the appliance using the flange that is provided.

Figure 4. – Mounting Burner in Appliance

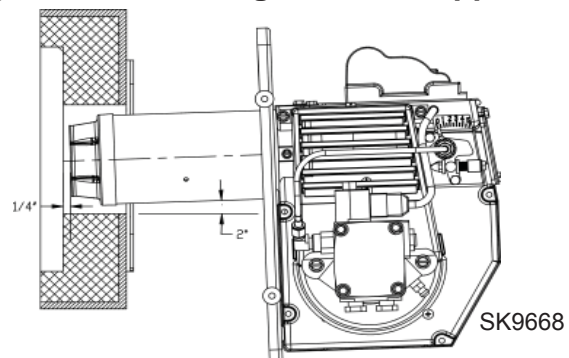

- **Connect Fuel Lines**

 **WARNING** **Oil Leak and Fire Hazard**

Install the oil tank following applicable standards in the U.S. by referring to the latest edition of NFPA 31 or CSA-B139 & CSA-B140 in Canada, and all authorities having jurisdiction.

 **CAUTION** **Do Not Use Teflon Tape**

Damage to the pump could cause impaired burner operation, oil leakage and appliance soot-up.

- Never use Teflon tape on fuel oil fittings.
 - Tape fragments can lodge in fuel line components and fuel unit, damaging the equipment and preventing proper operation.
 - Use oil-resistant pipe sealant compounds.
-

NOTICE To determine the proper fuel line size, refer to the fuel pump manufacturer's instructions provided with the burner. Refer to Figure 5 or Figure 6 for typical installation layouts.

The burner is supplied with either a one-stage pump or a two-stage pump based on the oil supply system requirements. Consult the instructions provided with the pump for installation specifications.

When installing a **one-pipe system**, connect the inlet line to the pump inlet. The fuel pump may be installed with gravity feed or lift. The maximum allowable lift for a single pipe installation is 8 ft.

When installing a **two-pipe system**, remove the 1/16" pipe bypass plug from plastic bag attached to fuel unit. Remove 1/4" plug from return port. Insert and tighten the bypass plug. Attach return and inlet lines. The return line should terminate approximately 3 to 4" above supply line inlet. Failure to do this may introduce air into the system and could result in loss of prime.

- **Fuel Line Installation**

Route the fuel line through the opening in the bottom of the burner cover. Continuous lengths of heavy wall copper tubing are recommended. Always use flare fittings. Never use compression fittings.

Inspect/Prepare Installation Site

Always install fittings in accessible locations. To avoid vibration noise, fuel lines should not run against the appliance or ceiling joists.

- **Fuel Line Valves and Filter**

Install two high quality, oil duty rated, fusible handle design shutoff valves in accessible locations on the oil supply line. Locate one close to the tank and the other close to the burner, upstream of the filter for service access.

Install a generous capacity filter inside the building between the fuel tank shutoff valve and the burner, locating both the filter and the valve close to the burner for ease of servicing. Filter should be rated for 50 microns or less.

NOTICE To further protect the fuel supply system and reduce nozzle orifice plugging with firing rates below 0.75 gph, a dual filtration system can be installed. This typically consists of a 50 micron primary filter, located near the fuel tank and a secondary filter rated for at least 10 microns located near the burner.

- **Fuel supply level with or above burner**

 **WARNING** **Do Not Install Bypass Plug with 1-Pipe System**

Failure to comply could cause immediate pump seal failure, pressurized oil leakage and the potential for a fire and injury hazard.

- The burner is shipped without the bypass plug installed.
 - Install the bypass plug in two-pipe oil supply systems **ONLY**.
-

 **CAUTION** **Oil Supply Pressure Control Required**

Damage to the filter or pump seals could cause oil leakage and a fire hazard.

- The oil supply inlet pressure to the burner **cannot exceed 3 psig**.
 - Insure that a pressure limiting device is installed in accordance with the latest edition of NFPA 31.
 - **Do NOT install valves in the return line.** (NFPA 31, Chapter 8.)
 - **Gravity Feed Systems:** Always install an anti-siphon valve in the oil supply line or a solenoid valve (RWB Part # 2182602U) in the pump/nozzle discharge tubing to provide backup oil flow cut-off protection.
-

Start the Burner and Set Combustion

The burner may be equipped with a single-stage fuel unit for these installations. Connect the fuel supply to the burner with a single supply line if you want a one-pipe system (making sure the bypass plug is NOT installed in the fuel unit.) Manual bleeding of the fuel unit is required on initial start-up. If connecting a two-pipe fuel supply, install the fuel unit bypass plug.

Fuel supply below the level of the burner

When the fuel supply is more than eight feet below the level of the burner, a two-pipe fuel supply system is required. Depending on the fuel line diameter and horizontal and vertical length, the installation may also require a two-stage pump. Consult the fuel unit manufacturer's literature, included with the burner, for lift and vacuum capability.

Fuel line installation –

- Continuous lengths of heavy wall copper tubing are recommended. **Always use flare fittings. Never use compression fittings.**
- Always install fittings in accessible locations. Proper routing of fuel lines is required to prevent air cavitation and vibration.

Figure 5. – Inside Tank Gravity Feed System

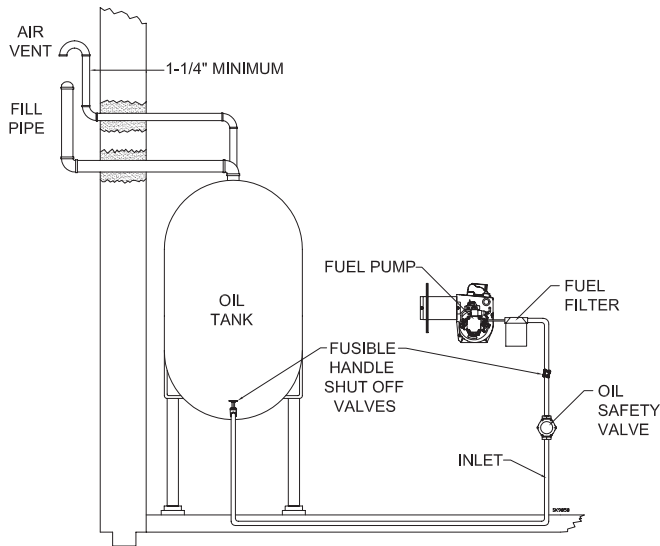
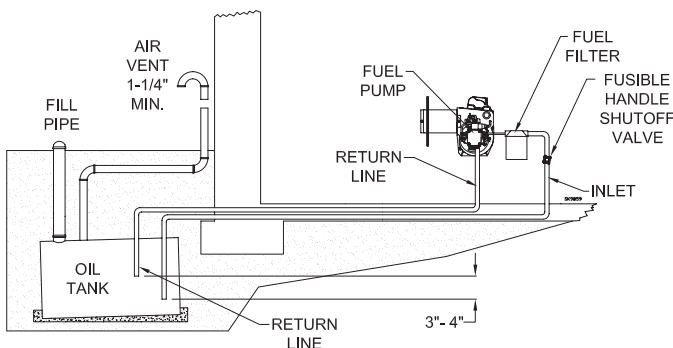

Figure 6. – Outside Buried Tank-Lift System



Wire burner



WARNING Electrical Shock Hazard

Electrical shock can cause severe personal injury or death.

- Disconnect electrical power before installing or servicing the burner.
- Provide ground wiring to the burner, metal control enclosures and accessories. (This may also be required to aid proper control system operation.)
- Perform all wiring in compliance with the National Electrical Code ANSI/NFPA 70 (Canada CSA C22.1)



CAUTION Incorrect Wiring Will Result in Improper Control

Operation

- GeniSys 7505 Control wiring label colors may not match the wire colors of the burner or other manufacturers' controls.
- The GeniSys Control should be wired according to the appliance manufacturer's instructions.

• **Burner packaged with appliance**

- Refer to appliance manufacturer's wiring diagram for electrical connections.

• **Burner installed at jobsite**

- Refer to Figures 7a and 7b, for typical burner wiring, showing cad cell primary controls. Burner wiring may vary, depending on primary control actually used.
- Refer to the appliance manufacturer's wiring diagram prior to connecting the burner wiring. All wiring must be in accordance with the latest revision of National Electric Code NFPA 70 and all local codes and regulations. In Canada, all wiring is to be in accordance with the Canadian Electrical Code, Part 1.

• **Special wiring required with covered burners**

The mounting plate is not a conduit connection point. Pass the conduit and attached connector through the opening in the mounting plate and attach it directly to the burner-mounted 4x4 electrical box.

If attaching a burner cover to a previously installed burner, attach the mounting plate and then slide the conduit into the "J" shaped conduit slot.

Start the Burner and Set Combustion

• Wiring Connections Diagram

WARNING Explosion, Fire, Scald, and Burn Hazard



All heating appliances must have HIGH LIMIT protection to interrupt electrical power and shutdown the burner if operating or safety controls fail and cause a runaway condition.

- Follow the appliance manufacturer's wiring diagrams and note all required safety controls.
- Typical safety controls include high temperature or pressure limits, low water cutoffs, pressure relief valves and blocked flue sensing switches.
- Verify all limit and safety controls are installed and functioning correctly, as specified by the manufacturer, applicable safety standards, codes and all authorities having jurisdiction.
- Ensure that the appliance is free of oil and oil vapor before starting or resetting the burner.

Refer to the appliance manufacturer's wiring diagram prior to connecting the burner wiring. All wiring must be in accordance with the latest revision of National Electric Code NFPA 70 and all local codes and regulations.

NOTICE

The 7505 primary control with valve-on delay (pre-time) and burner motor-off delay (post-time) requires a constant 120 volts AC power source supplied to the BLACK wire on the control. The RED wire goes to the appliance limit circuit. Please note that other control manufacturers may use different wire colors for power and limit connections.

- Make connections to the control's terminals as shown in **Figures 7a** and **7b**. Refer to the label on the underside of the control for wiring details.

NOTICE

Motor-off delay on a 7505P will be disabled if the safety and operating limits as shown in Figures 7a and 7b interrupt power to the control terminal L1.

- Connect thermostat leads to the TR and TW terminals on the control or jumper the TR and TW terminals on the control, as directed by the appliance wiring diagram.
 - Thermostat anticipator Current: 0.1 amp
 - Thermostat voltage: 24 volts AC

Figure 7a. – GeniSys 7505 Control interrupted ignition, valve-on delay only (no motor-off delay)

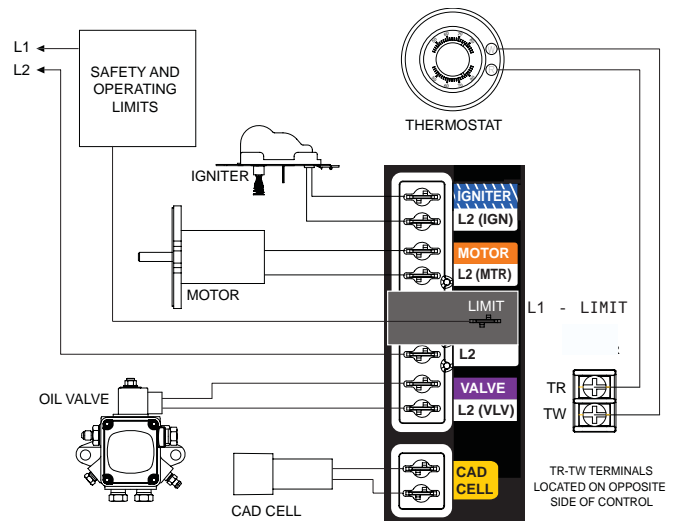
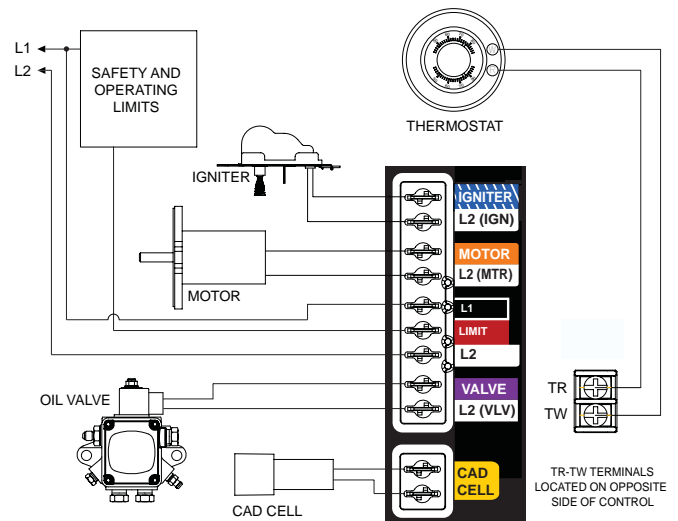

Figure 7b. – GeniSys 7505 Control Interrupted ignition, valve-on delay and motor-off delay



NOTICE

If the thermostat short cycles or operates improperly, it may require an isolation relay for proper operation. The Beckett A/C Ready Kit (part no. 51950U) provides this function. Wiring instructions are included with the A/C Ready Kit.

GeniSys Model 7505 Control

WARNING Fire or Explosion Hazard

Can cause severe injury, death, or property damage.

- The control can malfunction if it gets wet, leading to accumulation of oil or explosive oil vapors.
- Never install where water can flood, drip or condense on the control.
- Never use a control that has been wet - replace it.

Typical Burner Sequence of Operation for GeniSys 7505 Control.

Refer to the appliance manufacturer's wiring diagram for actual specifications.

- Standby:** The burner is idle, waiting for a call for heat.
- Valve-On Delay:** The igniter and motor are on while the control delays turning on the oil solenoid valve for the programmed time.
- Trial For Ignition:** The oil solenoid valve is energized. A flame should be established within the factory set trial for ignition time (lockout time).
- Lockout:** The control has shut down for one of the following safety reasons:
 - The trial for ignition (lockout) time expired without flame being established.
 - The cad cell detected flame at the end of the Valve On Delay state.

To reset the control from lockout click the button 1-second.

NOTE: A recurrence of the above failure modes or a failed welded relay check could cause the control to enter a **Hard Lockout** state that must be reset only by a qualified service technician.

To reset from Hard Lockout, hold the reset button for 15 seconds until the yellow light turns on.

- Ignition Carryover:** Once flame is established, the igniter remains on for 10 additional seconds to ensure flame stability.
- Run:** The flame is sustained until the call for heat is satisfied. The burner is then sent to Motor-Off Delay, if applicable, or it is shut down and sent to Standby.

7. Recycle: If the flame is lost while the burner is firing, the control shuts down the burner, enters a 60 second recycle delay, and repeats the ignition sequence. The control will continue to Recycle each time the flame is lost, until it reaches a pre-set time allotment. The control will then go into Hard Lockout instead of recycle. This feature prevents excessive accumulation of oil in the appliance firing chamber.

8. Motor-Off Delay: If applicable, the oil solenoid valve is turned off and the control delays turning the motor off for the set motor-off delay time before the control returns to standby.

9. Pump Prime: The igniter and motor are on with the oil solenoid valve energized for 4 minutes. During Pump Prime mode, the cad cell is disregarded, allowing the technician to prime the pump without having to jumper the cad cell.

10. Cad Cell Resistance Indicator: During the burner run state, click the reset button (less than 1 second) to check the cad cell resistance range. The yellow light will flash 1 to 4 times, depending on the amount of light detected by the cad cell. See chart below.

Yellow Light Flashes	Flame Detection Range
1	Normal (0-400 ohms)
2	Normal (400-800 ohms)
3	Normal (800-1600 ohms)
4	Limited (1600 ohms lockout)

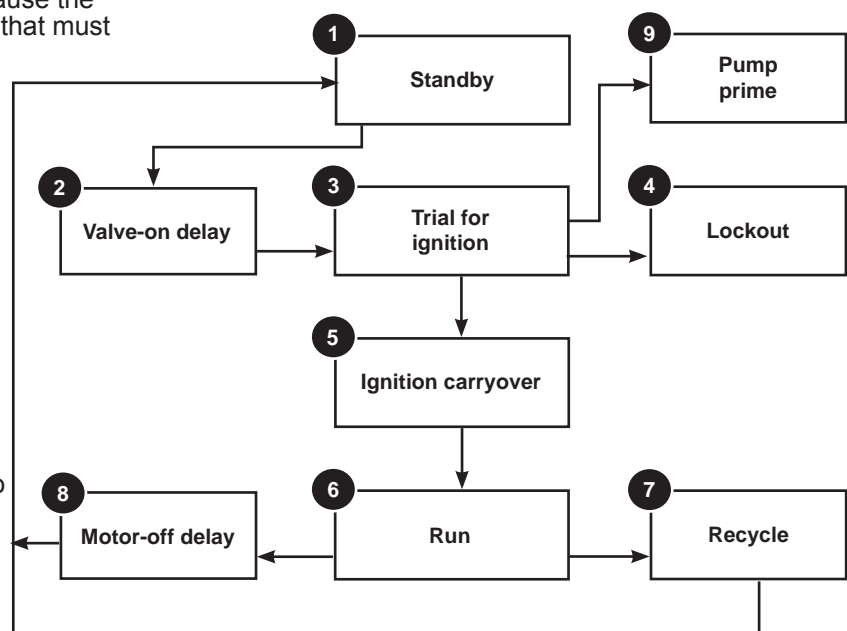
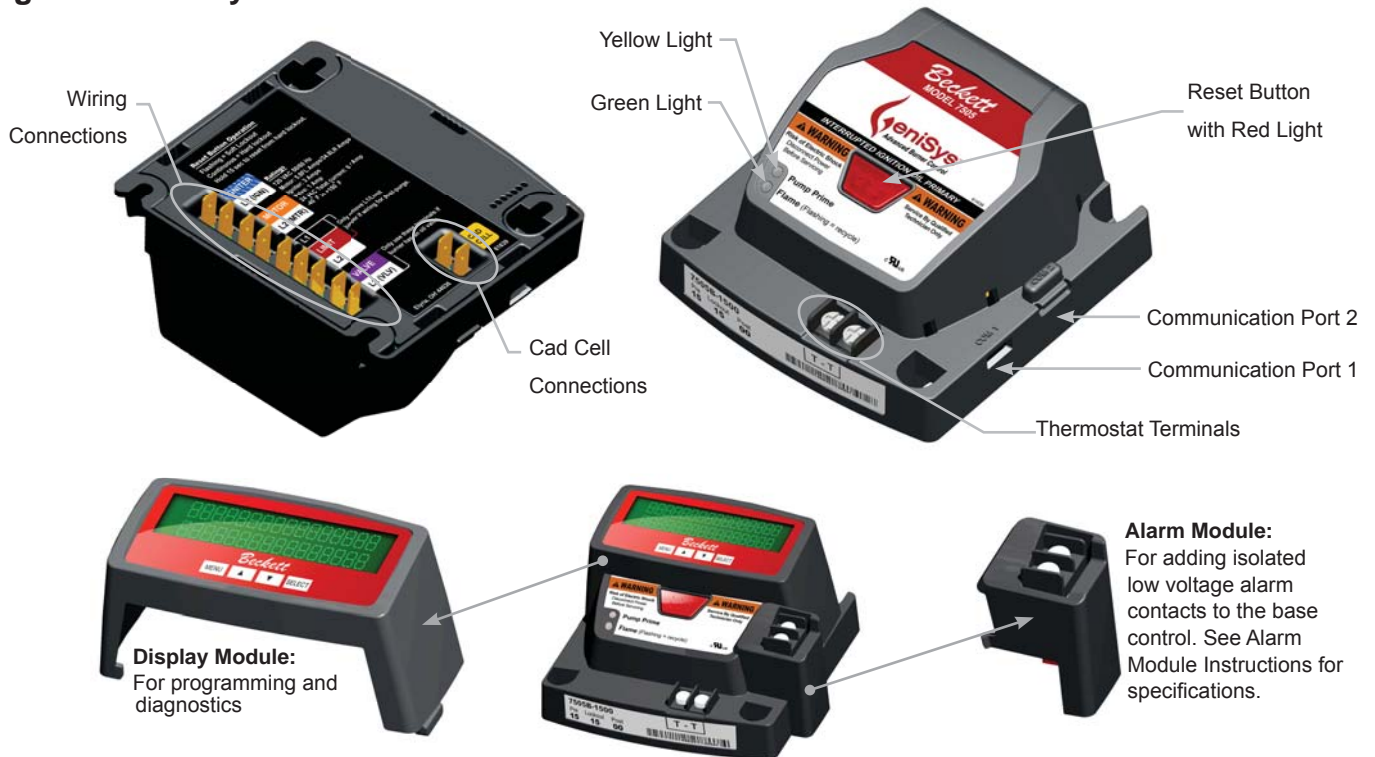

Figure 8. GeniSys Model 7505 Control



Reset Button Operation

Table 5 explains what action the control will take when the reset button is pressed for different lengths of time during the various burner operating states.

Table 5 - Reset Button Operation

If the burner is in the below state:	Pushing the reset button will:		
	Button Click (press < 1 second)	Button Hold (press > 1 second)	Button Hold (press 15+ seconds)
Lockout	Reset from Soft Lockout		Reset from Restricted (Hard) Lockout
Valve-on Delay, Trial for Ignition, Ignition Carryover	Go to Pump Prime (see "Priming the Pump" above)	Disable the Burner: Any time the burner is running, press and hold the reset button to disable the burner. The burner will remain off as long as the button is held.	Enables Pump Priming: After the reset button has been held for 15 seconds, the button can then be clicked during the next ignition sequence to enter Pump Prime mode.
Run (igniter is shut off)	Yellow light flashes to indicate cad cell resistance. See "Cad Cell Resistance Indicator" for table of resistance values.		
Motor-Off Delay, Standby	No action		
Pump Prime	No action	Exit Pump Prime mode and return to Standby	

Table 6 - Status Lights

Light Color	On Continuously	Flashing
Red	Restricted (Hard) Lockout	Soft Lockout
Green	Flame Sensed during normal operation (Could be stray light during standby)	Recycle
Yellow	Control is in Pump Prime mode or Reset button currently held for 15+ seconds.	Cad Cell resistance. See "Cad Cell Resistance Indicator" on Page 12, for a table of resistance values.

Burner Controls

Figure 9. Typical Burner Wiring & Burner Sequence of Operation for R7184P Control.

Refer to the appliance manufacturer's wiring diagram for actual specifications.

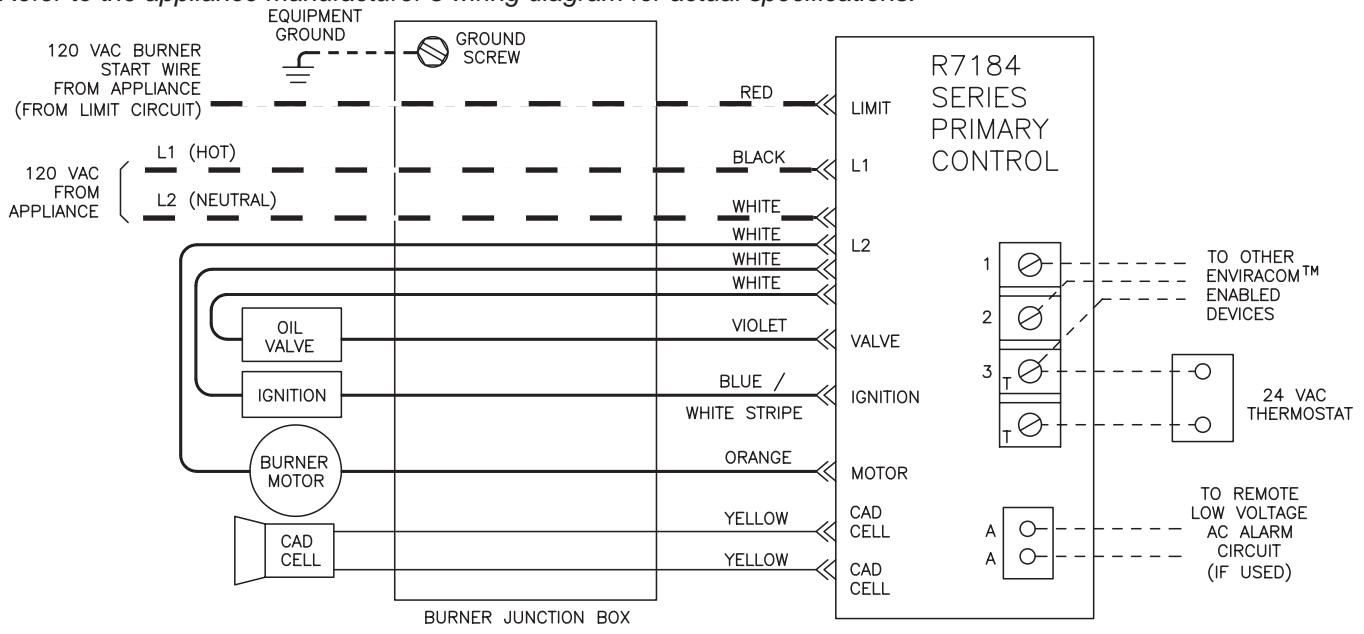

SK9359D ——— = 120 VAC FIELD WIRING - - - - - = LOW VOLTAGE FIELD WIRING ——— (with hook) = WIRE WITH 1/4" QUICK CONNECT RECEPTACLE SK9359

1. **STANDBY.** The burner is idle, waiting for a call for heat. When a call for heat is initiated, there is a 3-10 second delay while the control performs a safe start check.
2. **VALVE-ON DELAY.** The ignition and motor are turned on for a 15 second valve-on delay.
3. **TRIAL FOR IGNITION (TFI).** The fuel valve is opened. A flame should be established within the 15 second lockout time.
4. **LOCKOUT.** If flame is not sensed by the end of the TFI, the control shuts down on safety lockout and must be manually reset. If the control locks out three times in a row, the control enters restricted lockout.
5. **IGNITION CARRYOVER.** Once flame is established, the ignition remains on for 10 seconds to ensure flame stability before turning off. If the control is wired for intermittent duty ignition, the ignition unit stays on the entire time the motor is running.
6. **RUN.** The burner runs until the call for heat is satisfied. The burner is then sent to burner motor off delay, if applicable, or it is shut down and sent to standby.

7. **RECYCLE.** If the flame is lost while the burner is firing, the control shuts down the burner, enters a 60 second recycle delay, and then repeats the above ignition sequence. If flame is lost three times in a row, the control locks out to prevent cycling with repetitious flame loss due to poor combustion.
8. **BURNER MOTOR-OFF DELAY.** The fuel valve is closed and the burner motor is kept on for the selected motor-off delay time before the control returns the burner to standby.

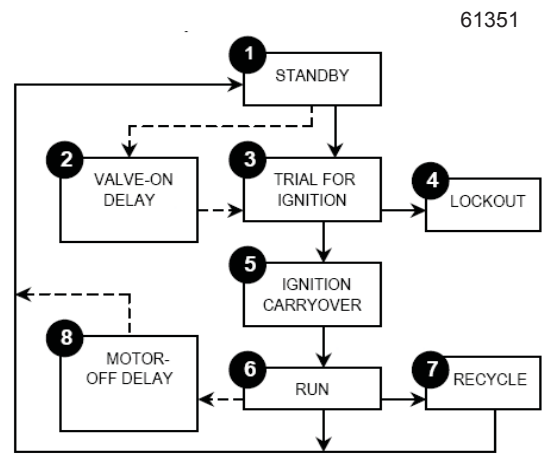

Control System Features

Feature	Interrupted ignition	Limited reset, Limited recycle	Diagnostic LED, cad cell indicator	Valve-on delay	Burner motor off delay	Alarm Contacts
R7184A	YES	YES	YES	—	—	—
R7184B	YES	YES	YES	YES	—	—
R7184P	YES	YES	YES	YES	YES	Optional

The R7184 primary control with valve-on delay and burner motor-off delay, shown in Figure 9, requires a constant 120 volt AC power source supplied to the black wire on the control. (Refer to the appliance manufacturer's instructions.) The red wire goes to the appliance limit circuit. Please note that other control manufacturers may use different wire colors for power and limit connections.

Start the Burner and Set Combustion

WARNING Hot Gas Puff-Back and Heavy Smoke Hazard

Failure to prime the pump properly could result in unstable combustion, hot gas puff-back and heavy smoke.

- Do not allow oil to spray into a hot combustion chamber while bleeding air from the pump.
- Install a gauge in the nozzle discharge port tubing or fully open the pump bleed valve to prevent oil spray from accumulating in the combustion chamber during the air bleed procedure.
- Ensure that all bubbles and froth are purged from the oil supply system before tightening the pump bleed valve.
- Ensure that the appliance is free of oil and oil vapor before starting or resetting the burner.

• Start-up and Initial Settings

1. Open the shutoff valves in the oil supply line to the burner.
2. Referencing Figure 10a or 10b, verify and/or set the Head/Air Adjustment Pointer to the value specified by the Appliance Manufacturer. If the Appliance Manufacturer's values are not available, refer to Table 7a or 7b. (***This is an initial air setting for the pump bleeding procedure only.***) Calibrated test instruments must be used for the final head/air adjustment.
3. Adjust the thermostat or temperature controller to call for heat. (*Note: return controller(s) to the original settings upon completion of burner installation or service.*)
4. Close the line voltage switch to start the burner. If the burner does not start within the 3 to 10 second safety start check timing, you may have to reset the safety switch on the burner primary control.
5. Bleed the air from the fuel pump as soon as the burner motor begins rotating.

6. Prepare for combustion tests by drilling a 1/4" sampling hole in the flue pipe between the appliance and the barometric draft regulator. Seal this hole when testing is complete. (See appliance manufacturer's instructions for location.)
7. **Check/Adjust Zero Calibration for older style Head/Air Adjustment Mechanism. Refer to Figure 10a.**
 - a. Loosen the splined nut and lower acorn nut approximately one turn. (DO NOT loosen the upper acorn nut. This is used only for setting the zero adjustment.) (See Figure 10a.)
 - b. A 5/16" nut driver or flat blade screwdriver can be used to turn the adjustment screw for head/air setting.
8. **Check/Adjust Zero Calibration for newer style Head/Air Adjustment Mechanism. Refer to Figure 10b.**
 - a. Slightly loosen the zero setting acorn.
 - b. Turn the screw until the reading is set to zero. (Mid-point of pointer should line up with zero.

Figure 10a. – Old Style Head/air Adjustment Plate

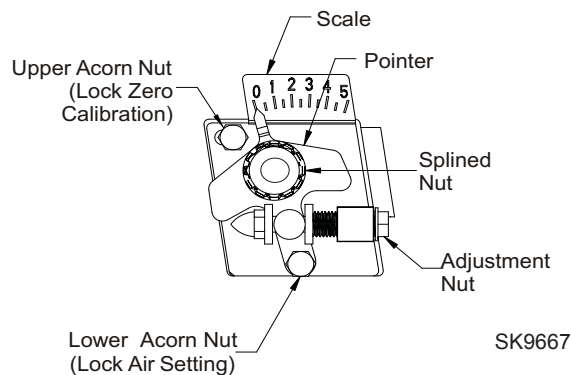
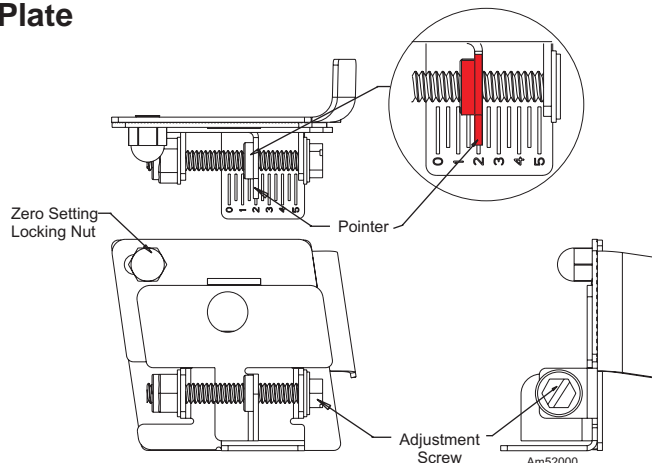

Figure 10b. – New Style Head/air Adjustment Plate



Start the Burner and Set Combustion

- c. Turn the air adjustment screw counterclockwise to adjust the plate with the pointer to the zero position.
- d. Slide the nozzle line assembly forward until the retention head engages the fixed stops in the retention ring at the end of the air tube.
- e. Tighten the zero setting acorn nut.
- f. The rear door must be closed. The adjustment screw may now be turned clockwise to adjust the head/air setting.
- g. Turn the adjusting screw to a setting 1/2 number lower than the proper setpoint as indicated in Tables 7a and 7b. Then turn the adjusting screw counterclockwise to the proper setting.
- h. Tighten the spline nut after the head/air setting has been adjusted.

Table 7a. – NX Burners

NX Air Tube & Head Combinations			
Head/Air Setting	LG - (9-slot head)	LB - (9-slot head)	LD - (9-slot head)
	LH - (6-slot head)	LC - (6-slot head)	LF - (6-slot head)
0.5	0.40 – 0.50	--	1.10 – 1.25
1.0	0.45 – 0.60	--	1.20 – 1.35
2.0	0.55 – 0.70	0.85 – 1.05	1.30 – 1.45
3.0	0.65 – 0.80	0.95 – 1.15	1.40 – 1.55
4.0	0.75 – 0.90	1.05 – 1.25	1.50 – 1.65
5.0	0.85 – 1.00	1.15 – 1.35	1.60 – 1.75

NOTICE The NX burner has a reduced diameter air tube, precision-designed air throttle cup and combustion head for improved performance. This design provides very accurate control of the air/fuel ratio, but the light reaching the cad cell through small holes in these components is limited. Because of this, **the average cad cell resistance may be higher than conventional burners** with larger openings.

Table 7b. – NX Burner with Low Fire Rate Baffle (LFRB) Installed

NX Air Tube & Head Combinations			
Head/Air Setting	LG - (9-slot head)	LB - (9-slot head)	LD - (9-slot head)
	LH - (6-slot head)	LC - (6-slot head)	LF - (6-slot head)
0.5	–	0.40 – 0.60	–
1.0	0.40 – 0.55	0.50 – 0.70	1.10 – 1.25
2.0	0.50 – 0.65	0.60 – 0.80	1.20 – 1.35
3.0	0.60 – 0.75	0.70 – 0.90	1.30 – 1.45
4.0	0.70 – 0.85	0.80 – 1.00	1.40 – 1.55
5.0	0.80 – 0.95	0.90 – 1.10	–

NOTICE Use factory-set or manufacturer’s recommended Head/Air Setting for ‘Starting the Burner and Setting Combustion’. The Head/Air Settings shown in Tables 7 are provided for reference purposes and represent a general range of rates and settings. Individual appliances, vent systems, and field conditions will impact the overall burner set up required for satisfactory combustion performance.

- **Set Combustion with Test Instruments**



OIL-BURNING EQUIPMENT SHALL BE CONNECTED TO FLUES HAVING SUFFICIENT DRAFT AT ALL TIMES TO ENSURE SAFE AND PROPER OPERATION OF THE BURNER.

1. Allow the burner to run for approximately 5 to 10 minutes.
2. Set the stack or over-fire draft to the level specified by the appliance manufacturer.
 - **Natural Draft Applications;** typically over-fire draft is -0.01" or -0.02" w.c.
 - **Direct Venting;** typically may not require draft adjustment.
 - **High Efficiency/Positive Pressure Appliances;** also vary from traditional appliances (see manufacturer's recommendations).
3. Follow these five steps to properly adjust the burner:
 - Step 1:** Adjust the head/air until a trace of smoke is achieved. This can be accomplished by turning the screw on the head/air adjustment plate assembly to increase air (CCW) or decrease air (CW).
 - Step 2:** At the trace of smoke level, measure the CO₂ (or O₂). This is the vital reference point for further adjustments. Example: 13.5% CO₂ (2.6% O₂)
 - Step 3:** Increase the air to reduce the CO₂ by 1.5 to 2 percentage points. (O₂ will be increased by approximately 2.0 to 2.7 percentage points.) Example: Reduce CO₂ from 13.5% to 11.5% (2.6% to 5.3% O₂).

- Step 4:** Recheck smoke level. It should be Zero. This procedure provides a margin of reserve air to accommodate variable conditions. If the draft level has changed, recheck the smoke and CO₂ levels and readjust burner, if necessary.
 - Step 5:** Once the combustion has been set, tighten the lower acorn nut and splined nut on the air adjustment assembly. See Figure 10a.
4. Chimney Vent Systems: Install the burner cover and repeat Steps 2 and 4 above. If CO₂ increases (O₂ decreases), remove the cover and adjust the air setting so the CO₂ (O₂) with the cover installed meets the requirements of Step 3.
 5. Direct Vent Systems with outside air ducted to burner: Install the burner cover.
 6. Start and stop the burner several times to ensure satisfactory operation. Test the primary control and all other appliance safety controls to verify that they function according to the manufacturer's specifications.

- **Cover Installation**

1. Install the four cover mounting thumb screws in the cover mounting plate.
2. Install the cover over the mounting plate while aligning the side slots with the installed cover mounting screws. The latest cover design has special tabs that push into slots in the mounting plate.

Perform Regular Maintenance

Trained Service Technician's Regular Maintenance

WARNING Annual Professional Service Required



Tampering with or making incorrect adjustments could lead to equipment malfunction and result in asphyxiation, explosion or fire.

- DO NOT TAMPER WITH THE UNIT OR CONTROLS - CALL YOUR QUALIFIED SERVICE TECHNICIAN OR SERVICEMAN.
- To ensure continued reliable operation, a qualified service technician must service this burner annually.
- More frequent service intervals may be required in dusty or adverse environments.
- Operation and adjustment of the burner requires technical training and skillful use of combustion test instruments and other test equipment.

The following guidelines are provided for routine maintenance.

- Replace the oil supply line filter. The line filter cartridge must be replaced to avoid contamination of the fuel pump and nozzle.
- Inspect the oil supply system. All fittings should be tight and leak-free. The supply lines should be free of water, sludge and other restrictions.
- Remove and clean the pump strainer if applicable.
- Replace the used nozzle with a new nozzle that conforms to the appliance manufacturer's specifications.
- Clean and inspect the electrodes for damage, replacing any that are cracked or chipped.
- Check electrode tip settings. Replace electrodes if tips are rounded.
- Inspect the igniter spring contacts.
- Clean the cad cell lens surface, if necessary.
- Make sure Low Firing Rate Baffle is in place if required for the burner application. Omitting the baffle can result in unacceptable burner combustion.

- Inspect all gaskets. Replace any that are damaged or would fail to seal adequately.
- Clean the blower wheel, air inlet, air guide, retention head, throttle cup and throttle ring of any lint or foreign material.
- Use a clean soft cloth with a degreaser to clean any accumulated soot or oil stains from the throttle cup sight windows.

WARNING Do Not Puncture, Scratch, or Remove Flame Sighting Windows



If a window is punctured, significantly scratched or removed from the throttle cup, the burner performance could be impaired, resulting in safety lockout, appliance soot-up, equipment damage, hot gas puff-back and asphyxiation hazard.

- Use a clean soft cloth and degreaser, on an annual basis, to remove any build-up or dark stains from the windows.
- If damaged, replace the nozzle line assembly with an assembly that has a windowed throttle cup.

-
- Check motor current. The amp draw should not exceed the nameplate rating.
 - Check all wiring for secure connections or insulation breaks.
 - Check the pump pressure and cutoff function.
 - Check primary control safety lockout timing.
 - Check ignition system for proper operation.
 - Inspect and clear the vent system and chimney of any soot accumulation or other restriction.
 - Clean the appliance thoroughly according to the manufacturer's recommendations.
 - Check the burner performance. Refer to the section "Set combustion with test instruments".
 - It is good practice to keep a record of the service performed and the combustion test results.

Perform Regular Maintenance

- **Removing Nozzle Line for Service** (Reference the Replacement Parts Diagram.)

WARNING Correct Nozzle and Flow Rate Required

 **Incorrect nozzles and flow rates could result in impaired combustion, under-firing, over-firing, soot-ing, puff-back of hot gases, smoke and potential fire or asphyxiation hazards.**

Use only nozzles having the brand, flow rate (gph), spray angle and pattern specified by the appliance manufacturer or Beckett Residential Burner OEM Spec Guide, Part #6711.

Follow the appliance manufacturer's specifications for the required pump outlet pressure for the nozzle, since this affects the flow rate.

- Nozzle manufacturers calibrate nozzle flow rates at 100 psig.
- This burner utilizes pressures higher than 100 psig, so the actual nozzle flow rate will be greater than the gph stamped on the nozzle body. (Example: A 1.00 gph nozzle @ 140 psig = 1.18 gph)

For typical nozzle flow rates at various pressures see accompanying chart.

1. Before proceeding, turn off the main power switch to the burner.
2. Remove the burner cover by loosening the four thumb screws (two on each side of burner).
3. Disconnect the copper connector tube assembly from the nozzle line bulkhead fitting.
4. Loosen the two screws securing the igniter retaining clips and rotate both clips to release the igniter baseplate. The igniter should pop up and be supported by the prop spring.
5. Loosen the two screws securing the rear door. Swing the door to the right and down.
6. Loosen the splined nut.
7. Remove the nozzle line electrode and head assembly from the burner by drawing it straight back and out the rear door opening. The adjustment mechanism is still attached. Be careful not to damage the electrodes or insulators while handling.
8. To replace the nozzle assembly, reverse the above procedure.

- **Nozzle Installation**

CAUTION Protect Nozzle from Damage

A damaged nozzle could cause impaired combustion, sooting, puffback of hot gases, smoke, oil leakage and potential fire or asphyxiation hazards.

- Use care when handling, removing and installing oil nozzles.
- Carefully follow the guidelines provided in this section.

Perform the following steps when replacing a nozzle.

1. Remove the nozzle line assembly to gain access to the nozzle.
2. Use a 3/4" open-end wrench to hold the nozzle adapter. DO NOT attempt to remove or replace the nozzle without securing the adapter, as nozzle alignment could be seriously affected.
3. Do not squeeze the electrodes when handling the nozzle line assembly. Excessive force could change the electrode tip settings or damage the ceramic electrode insulators.

Table 8. Nozzle Flow Rate by Size

Nozzle flow rate U. S. gallons per hour of No. 2 fuel oil when pump pressure (psig) is:					
Nozzle size (rated at 100 psig)	125 psi	140 psi (factory std.)	150 psi	175 psi	200 psi
0.40	0.45	0.47	0.49	0.53	0.56
0.50	0.56	0.59	0.61	0.66	0.71
0.60	0.67	0.71	0.74	0.79	0.85
0.65	0.73	0.77	0.80	0.86	0.92
0.75	0.84	0.89	0.92	0.99	1.06
0.85	0.95	1.01	1.04	1.13	1.20
0.90	1.01	1.07	1.10	1.19	1.27
1.00	1.12	1.18	1.23	1.32	1.41
1.10	1.23	1.30	1.35	1.46	1.56
1.20	1.34	1.42	1.47	1.59	1.70
1.25	1.39	1.48	1.53	1.65	1.77
1.35	1.51	1.60	1.65	1.79	-
1.50	1.68	1.77	1.84	-	-
1.65	1.84	-	-	-	-
1.75	-	-	-	-	-

Perform Regular Maintenance

Figure 11. – Nozzle Line/Head/Air Tube Assembly (Low firing rate shown.)

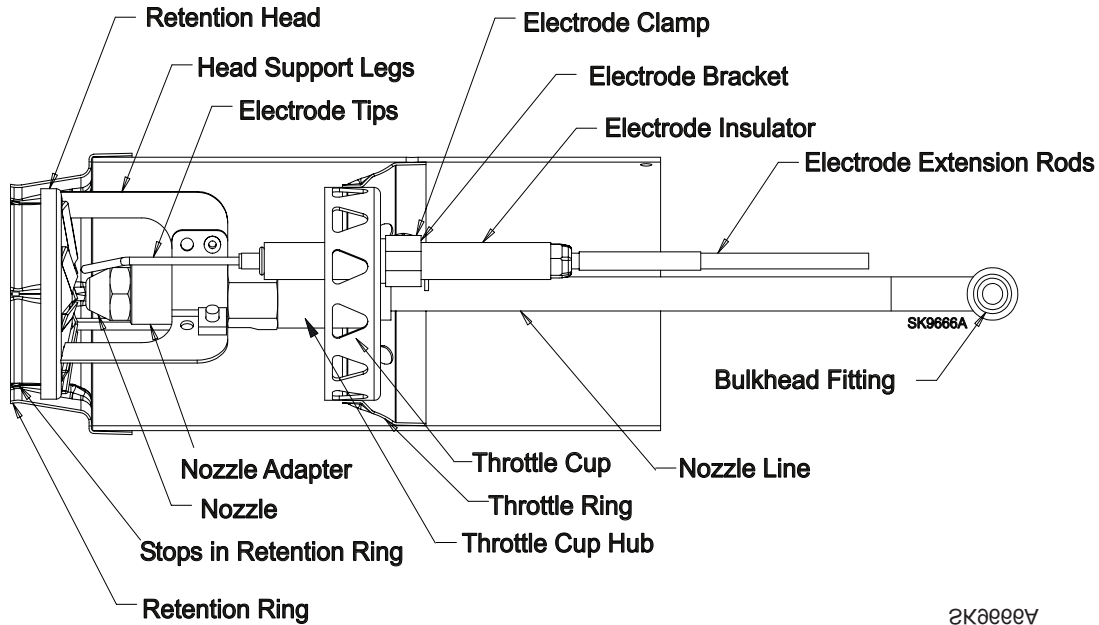

4. Use a 5/8" open-end wrench to carefully remove the existing nozzle.
5. Inspect the nozzle adapter before installing the new nozzle. If it is grooved or scratched on the sealing surface, replace the nozzle line assembly. If the surface is damaged, oil could leak at the nozzle to adapter joint, causing serious combustion problems.
6. Protect the nozzle orifice and strainer when installing. If the orifice gets dirt in it or is scratched, the nozzle will not function properly.
7. To install a new nozzle, place a 3/4" open-end wrench on the nozzle adapter. Insert the nozzle into the adapter and secure finger tight. Finish tightening with a 5/8" open-end wrench. Use care to avoid bending the burner head support legs or electrodes.
8. Do not over-torque the nozzle when installing. This will cause deep grooves in the nozzle adapter, preventing a seal when a new nozzle is installed.
9. Carefully check and realign the electrode tips after replacing a nozzle, ensuring the electrode settings comply with Figure 11.
10. If the head was removed when replacing the nozzle, carefully reconnect the head to the nozzle adapter. Make sure to align the key in the support leg with the keyway in the nozzle adapter and to butt the head support to the nozzle adapter shoulder, see Figure 12.

• Check/Adjust Electrodes

Check the electrode tip settings, as shown in Figure 11. If necessary, adjust by loosening the electrode clamp screw (Figure 12) and slide/rotate the electrodes as necessary. When the adjustment is complete, securely tighten the clamp screw.

Note that if the throttle cup is moved be sure to reposition it with no gap between the nozzle adapter and hub.

Figure 12. – Electrode tip gap and spacing

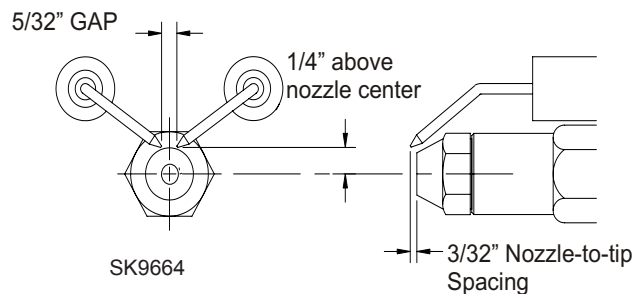

• Check Retention Head Alignment and Cad Cell Sighting (Refer to Figure 13.)

The cad cell sighting holes in the throttle cup and the retention head must be aligned to allow the cad cell to detect the flame. Make sure the stamped key in the retention head collar lines up with the keyway in the nozzle adapter when mounting the retention head. Note that in specific applications, the retention head may not have a sighting hole.

Figure 13 – Retention Head/Throttle Cup Alignment

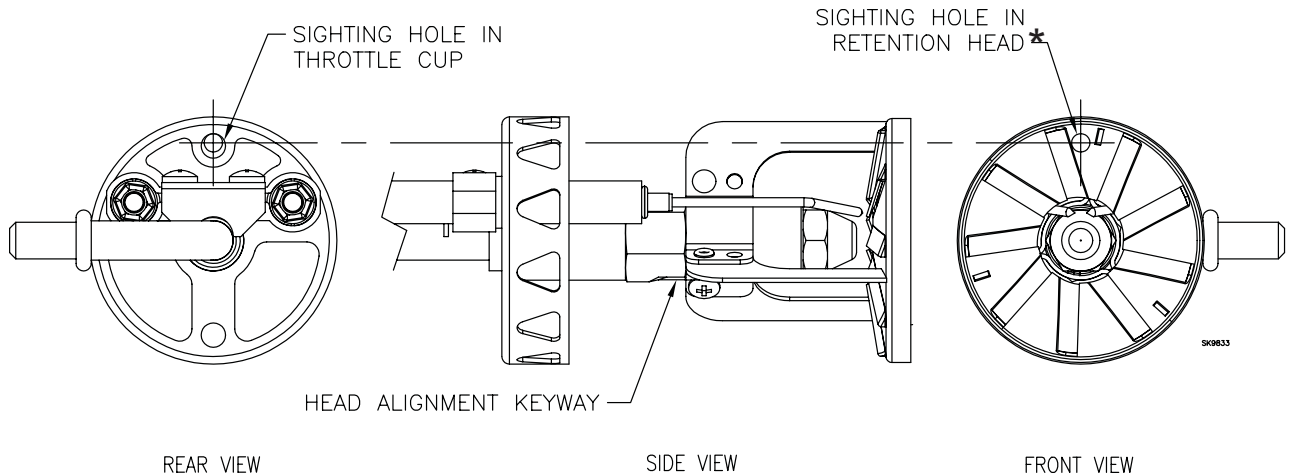

* NOTE THAT FOR SPECIFIC APPLICATIONS, THE RETENTION HEAD MAY NOT CONTAIN A SIGHTING HOLE.

• Check/Adjust “Zero” Calibration

On burners with factory-installed air tubes, the zero calibration has been factory set. Make sure the retention head (Figure 11) is securely against the stops in the retention ring when the adjustment plate pointer is at “0” (Figure 10).

If the zero calibration has not been set, perform the following procedure:

1. Install the nozzle line, with the adjustment plate assembly attached, into the burner.
2. Install and tighten the rear door to hold the air adjustment plate assembly in position.
3. Slightly loosen the upper acorn nut, the splined nut, and the lower acorn nut.
4. Turn the air adjustment screw clockwise to adjust the plate with the pointer to the zero position.
5. Referring to Figure 8, slide the nozzle line assembly forward until the retention head engages the fixed stops in the retention ring at the end of the air tube.
6. Tighten the upper acorn nut securely.
7. The rear door must be kept tightly closed. The adjustment screw may now be turned to adjust the head/air setting.
8. Turn the adjusting screw to a setting that is 1/2 number lower than the proper set point as indicated in Table 1. Then turn the adjusting screw counterclockwise to the proper setting.
9. Tighten the splined nut and lower acorn nut after the head/air setting has been adjusted.

• Blower Wheel Replacement

For installation or replacement of a blower wheel, insure that there is a space between the blower wheel and the motor face of 0.115”. Refer to Figure 14.

Figure 14. – Blower wheel assembly

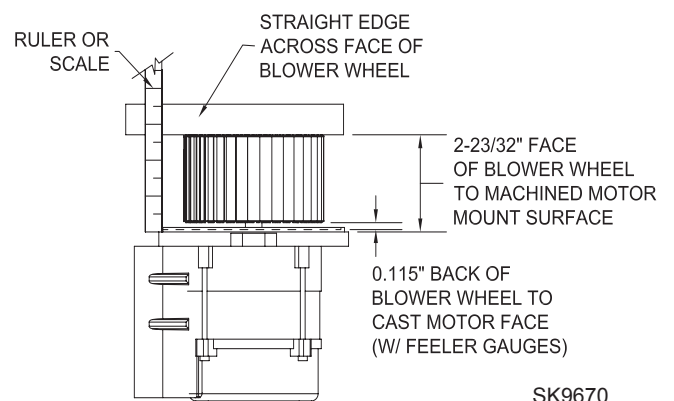

Replacement Parts Diagram

For best performance specify genuine **Beckett** replacement parts

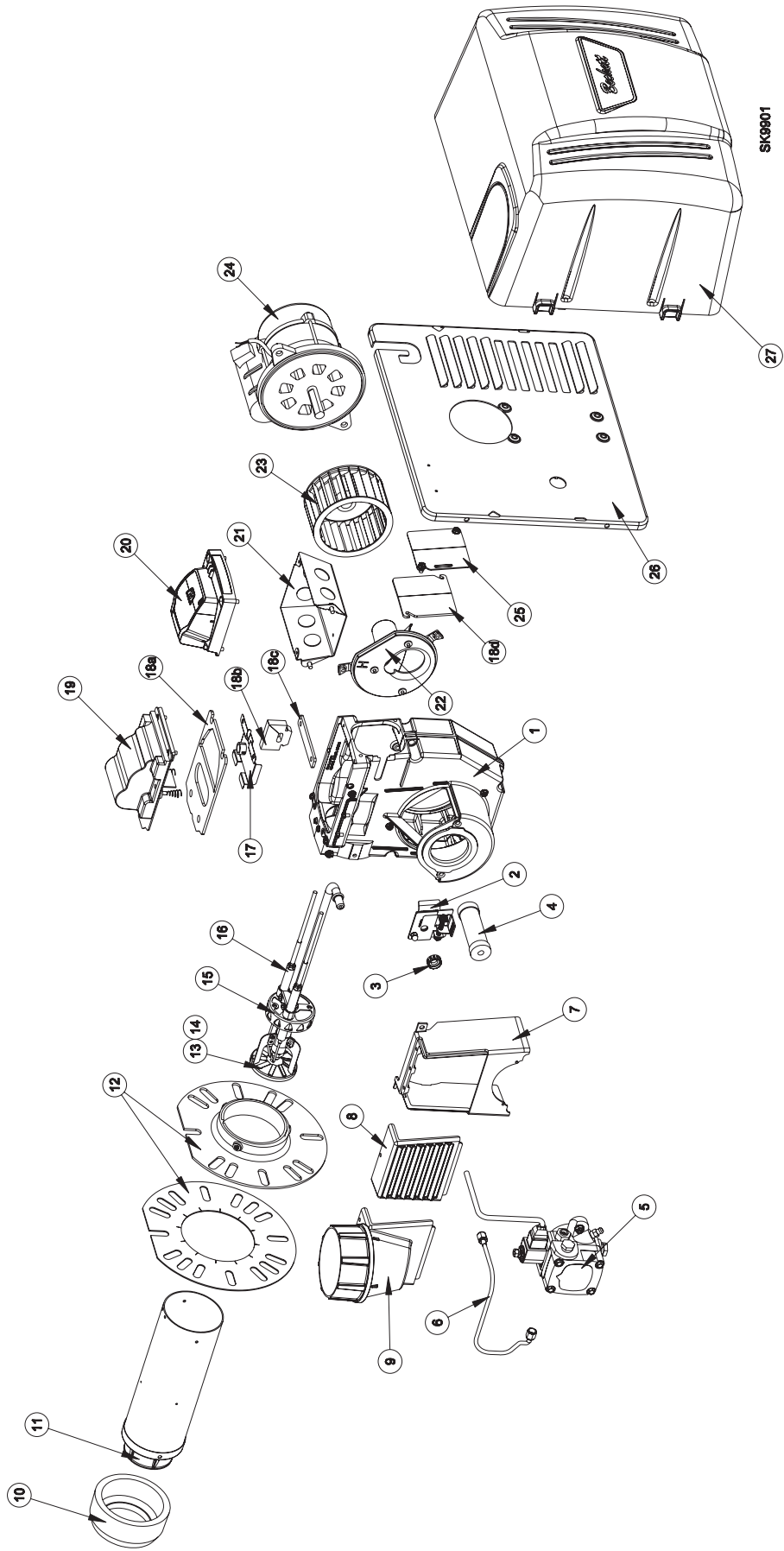

Replacement Parts List

Item	Description	Part No.
1	Air guide	101101U
2	Head/Air adjustment mechanism assembly	52000U
3	Splined nut	3666
4	Coupling	2454
5	CleanCut Fuel Pump, (Includes Mounting Screws 1/4 - 20 x 7/8" - Part # 4189)	2184404U
6	Connector tube assembly, 11"	51127
7	Inlet air box	1010U
8	Inlet air louvers	1013U
9	Inlet Air Adapter, Outside air kit	1014U
10	Retention head assembly, 6 -slot *	51785U
11	Retention head assembly, 9 -slot *	51815U
12	Air tube combination, (Includes Screws, air tube mounting #8 x 3/8 - Part # 4396)	Specify
13	Heat Shield (per specification)	Specify
14	Nozzle Line Electrode and Head Assembly, with window	Specify
15	Electrode insulator kit	51811U
16	Spring, igniter prop	32058U

Item	Description	Part No.
17	Igniter, electronic	51771U
18	Gasket, Igniter Kit	51942U
18a	Gasket, igniter baseplate	
18b	Gasket, wiring hinge	
18c	Gasket, igniter baseplate hinge	
18d	Gasket, rear access door	
19	Low Fire Rate Baffle (per specification)	32229U
20	Replaces R7184A - Interrupted Ignition	7505A
	Replaces R7184B - Pre-purge	7505B
	Replaces R7184P - Pre and Post-purge**	7505P
21	PSC Motor, (Requires mounting screw 1/4-20 x 7/8 - Part#4189)	21805U
22	Electrical Box	5770
23	Blower wheel	2999U
24	Door, rear access	32119U
25	Cover, Burner	52064xxU**
26	Mounting Plate, Burner Cover	32103U
27	Thumbscrew, Cover mounting	21899
	Universal Adjustable Flange Kit. Includes 32086 Gasket.	51801U

* For retention head assemblies that do NOT have a sighting hole, contact Beckett's customer service for appropriate part number.

** Contact your Beckett Representative for part number and pricing.

Limited Warranty Information

Limited WARRANTY

For Residential, Commercial and Specialty Burners

The R. W. BECKETT CORPORATION ("Beckett") warrants to persons who purchase its Beckett burners from Beckett for resale or for incorporation into a product for resale ("Customers") that its equipment is free from defects in material and workmanship under normal use and service for 60 months from the date of manufacture for Residential Burners and 18 months from the date of manufacture for Commercial and Specialty Burners. *Residential burner models include:* AF, AFG, AFIL, NX, SF, SR and SMG. *Commercial burner models include:* CF375, CF500, CF800, CF1400, CF2300A, CF2500, CF3500A, CG10, CG15, CG25 and CG50. *Specialty burner models include:* ADC, ADCP, ARV, SDC and SM. The provisions of this warranty are extended to individual major burner components as follows:

- a) 60 months from date of manufacture for all Beckett-branded major components, except for 12 Vdc components.
- b) 18 months from date of manufacture for all non-Beckett-branded major components and Beckett branded 12 Vdc components.

Note: Normal service items found to be defective upon receipt by the customer are covered by this warranty.

THIS WARRANTY DOES NOT EXTEND TO EQUIPMENT SUBJECTED TO MISUSE, NEGLIGENCE, OR ACCIDENT; NOR DOES THIS WARRANTY APPLY UNLESS THE PRODUCT COVERED BY IT IS PROPERLY INSTALLED BY A QUALIFIED, COMPETENT TECHNICIAN, WHO IS LICENSED WHERE STATE AND LOCAL CODES REQUIRE, AND WHO IS EXPERIENCED IN MAKING SUCH INSTALLATIONS, IN ACCORDANCE WITH THE LATEST EDITION OF NFPA NO. 31 OF THE NATIONAL FIRE PROTECTION ASSOCIATION, THE LATEST EDITION OF THE NATIONAL FUEL GAS CODE (NFPA NO. 54) AND IN ACCORDANCE WITH ALL APPLICABLE LOCAL, STATE AND NATIONAL CODES HAVING JURISDICTIONAL AUTHORITY.

Equipment, which is defective in material or workmanship and within the warranty period, may be returned for credit as follows:

Beckett Burners, Beckett-branded major components and non-Beckett-branded major components that came as original equipment on a Beckett burner or were sold as a replacement part by Beckett should be returned, freight prepaid, to Beckett's home office. Credit will be issued to the customer unless the returned equipment is determined by Beckett to be out of warranty or damaged by user, in which case the equipment will be scrapped.

Note: Beckett is not responsible for any labor cost for removal and replacement of equipment.

THIS WARRANTY IS LIMITED TO THE PRECISE TERMS SET FORTH ABOVE, AND PROVIDES EXCLUSIVE REMEDIES EXPRESSLY IN LIEU OF ALL OTHER REMEDIES, AND IN PARTICULAR THERE SHALL BE EXCLUDED THE IMPLIED WARRANTIES OF MERCHANTABILITY AND FITNESS FOR A PARTICULAR PURPOSE. IN NO EVENT WILL BECKETT BE LIABLE FOR ANY INCIDENTAL OR CONSEQUENTIAL DAMAGE OF ANY NATURE. Beckett neither assumes nor authorizes any person to assume for Beckett any other liability or obligation in connection with the sale of this equipment, Beckett's liability and Customer's exclusive remedy being limited to credit as set forth above.

R.W. BECKETT CORPORATION

P.O. Box 1289 Elyria, Ohio 44036

Form No. 61545 R72905

The Oilheat Manufacturers' Association supports the use of low sulfur fuels as defined by ASTM D396, Grades No. 1 Low Sulfur and No. 2 Low Sulfur, as the preferred heating fuel for the following reasons:

- Low sulfur fuels reduce deposits on heat exchanger surfaces, extending the service interval between cleanings.
- The reduced deposits increase the efficiency of the appliance.
- Low sulfur fuels reduce particulate emissions.
- Low sulfur fuels reduce oxides of nitrogen emissions.

R.W. BECKETT CORPORATION

U.S.A.: P.O. Box 1289 · Elyria, Ohio 44036

www.beckettcorp.com

Canada: R.W. Beckett Canada, Ltd. · Unit #3, 430 Laird Road · Guelph, Ontario N1G 3X7

Form Number 6104 BNX R04

Printed in the U.S.A. April, 2008