

Owners Manual

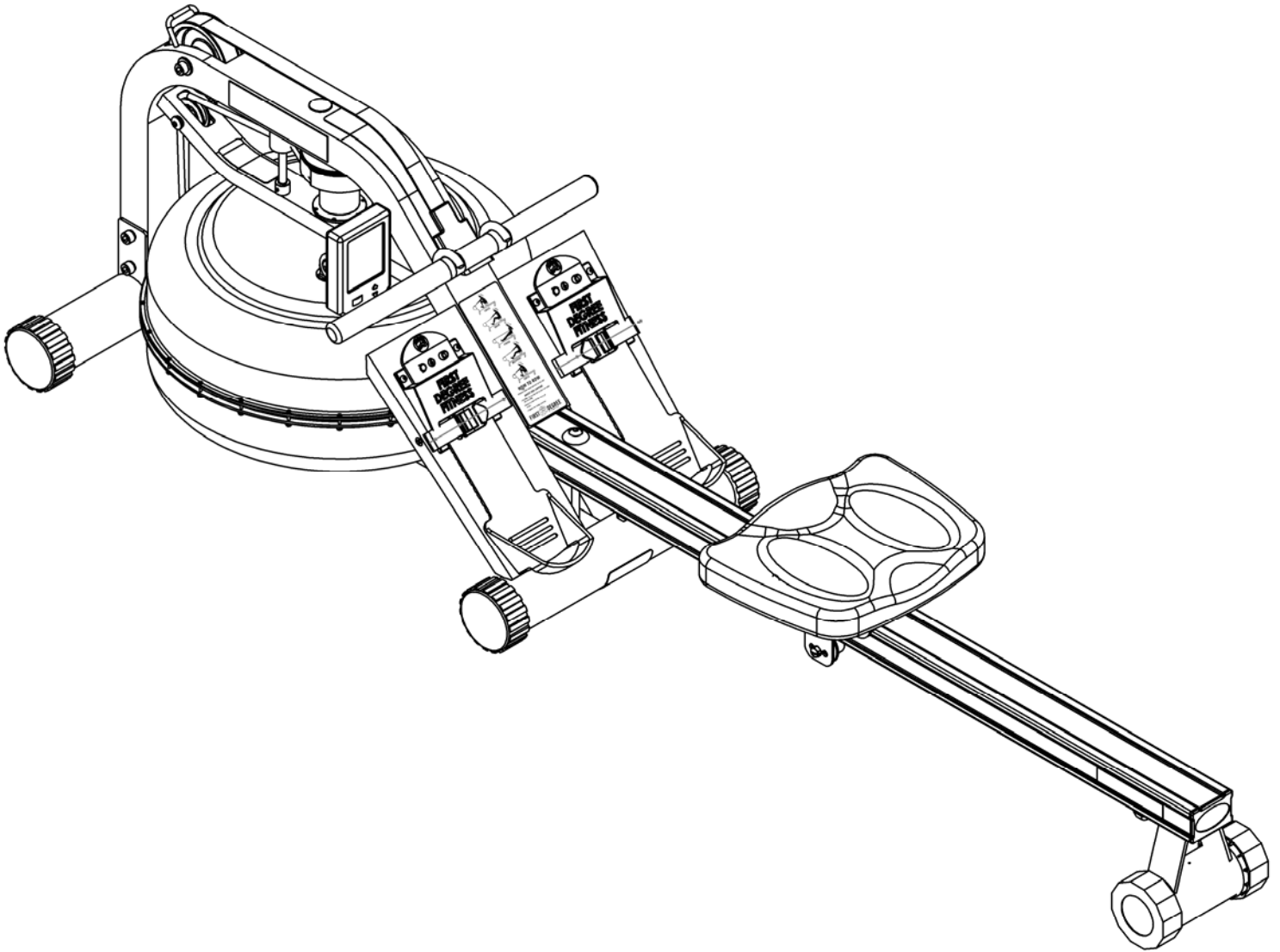

PACIFICChallenge **AR**



FIRST DEGREE FITNESS
FLUID INNOVATION

www.firstdegreefitness.com

Contents

1. Contents of Pacific Challenge AR Pack.
2. Assembly.
3. Tank Filling and Water Treatment.
4. Operational Instructions.
5. The Pacific Challenge AR Computer with optional USB Function.
6. Replacing Rower Belt.
7. Changing Bungee Shock Cord.
8. Maintenance and Troubleshooting.
9. Parts List.
10. Warranty.

Training with the Pacific Challenge AR

1. As with any piece of fitness equipment, consult a physician before beginning your Pacific Challenge AR Exercise Program.
2. Follow instructions provided in this manual for correct foot position and basic rowing techniques.



1. The Pacific Challenge AR can stand vertically for storage. Make sure a secure location is chosen, such as in the corner of a room.
2. Keep hands and fingers away from moving parts, as indicated by the warning sticker on the mainframe of your machine.

Pacific Challenge AR Box Contents

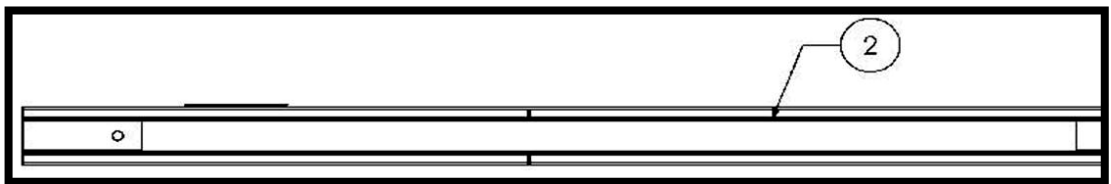
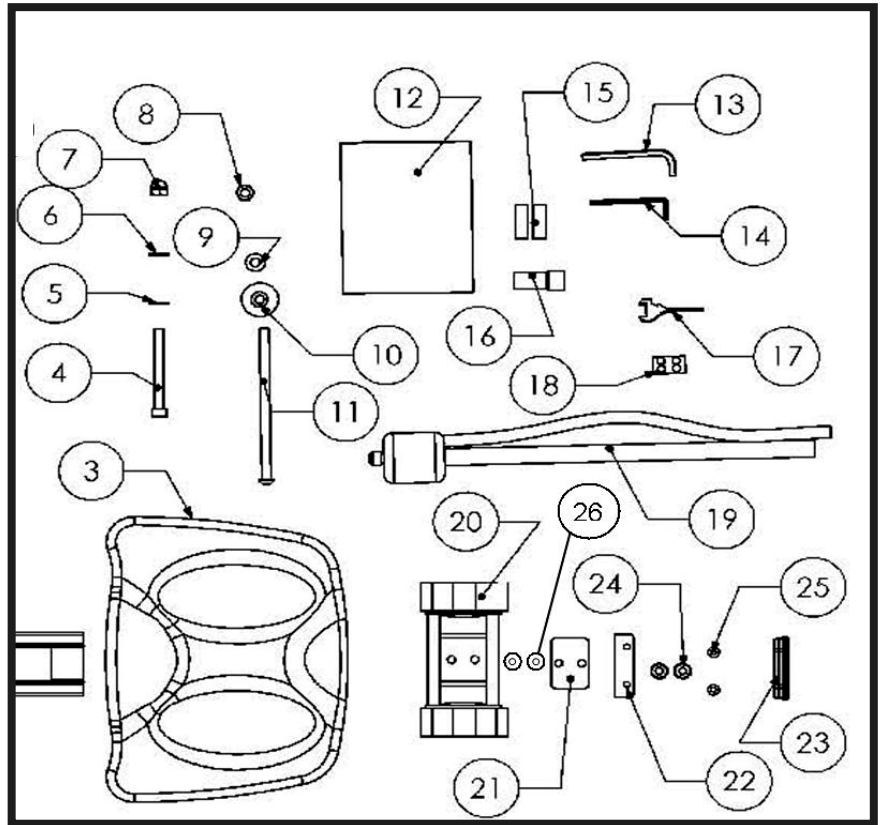
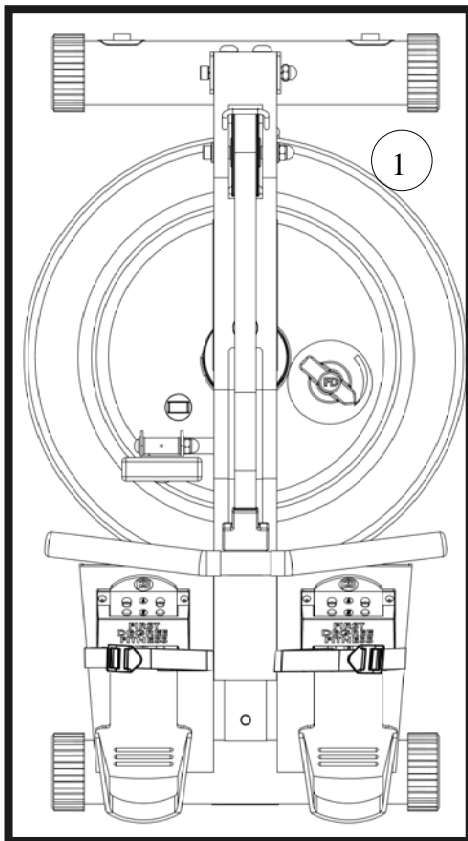

Inside your Pacific Challenge AR box, you will find the following components and parts:

Item	Description	Item	Description
1	Main Frame	14	6mm Hex key
2	Seat Rail (boxed separately)	15	AA batteries (x2)
3	Rower Seat	16	3cc blue dye glass vial
4	M10x95mm bolt	17	Multi-tool
5	M10 Washer	18	Water treatment pack (4x tablets)
6	M10 Washer	19	Siphon
7	M10 Dome nut	20	Rear seat rail leg
8	M10 Nylock nut	21	Rear seat rail leg mounting bracket
9	M10 Washer	22	Rubber bump-stop for seat rail (rear)
10	Plastic Dome cap	23	Seat rail rubber end cap
11	M10x180mm seat rail bolt	24	M8x15mm rear leg bolts (x2)
12	Owners manual	25	M6x10 countersink bolts (x2)
13	8mm Hex key	26	M8 Washer (x2)

Installing the Seat and Rear Leg to Seat Rail

Install the Rower Seat onto the Seat Rail as shown, with seat indentation facing rearward.

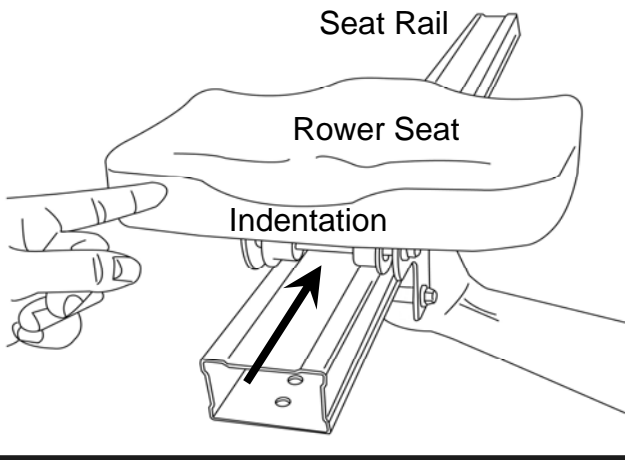

Next, install Rear Bumpstop on underside of Seat Rail using 2x M6x10mm bolts. Beveled edge must face forward.

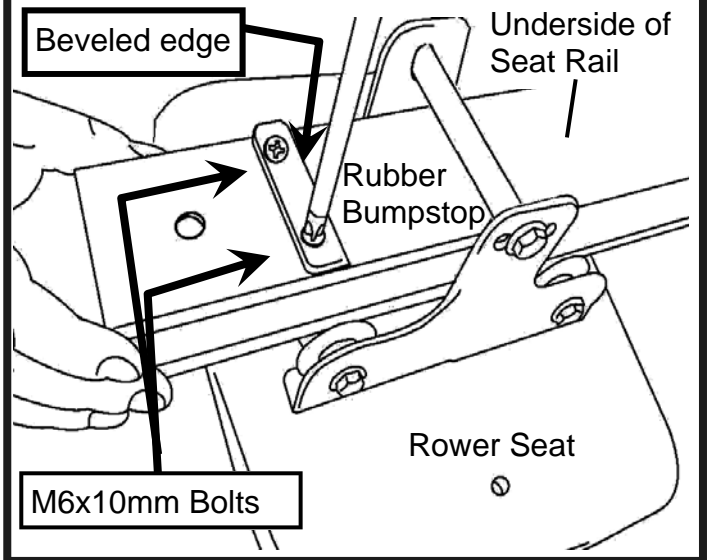

Rear Leg Assembly

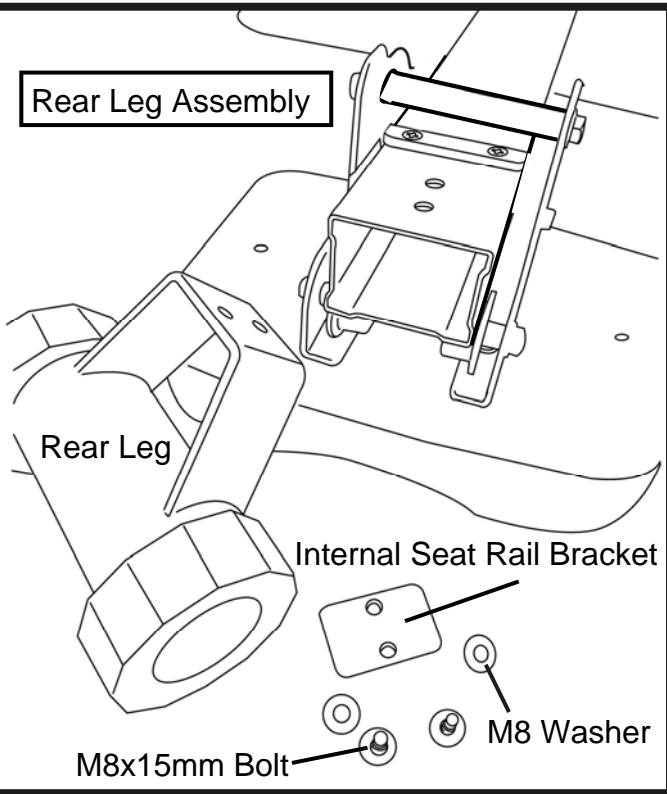

Internal Seat Rail Bracket

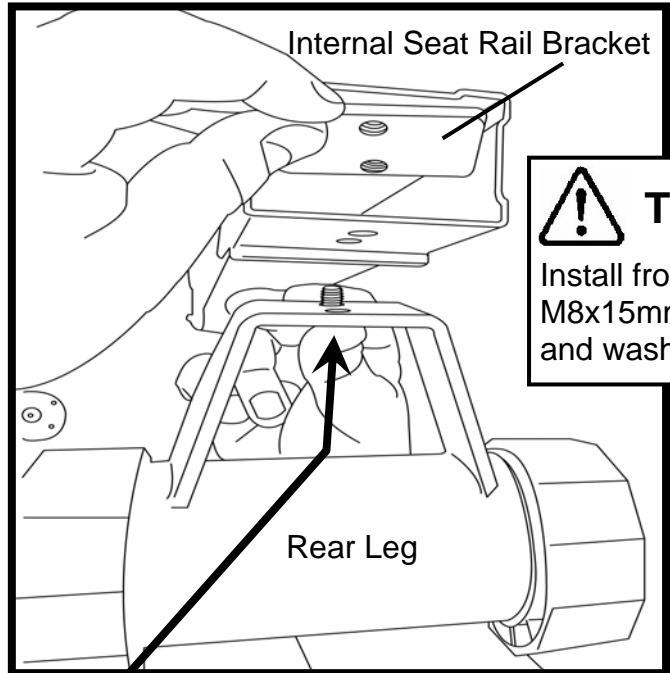

Tip:
Install front M8x15mm bolt and washer first

Mount Rear Leg as shown, aligning the M8x15 bolts and washers up through the Rear Leg, the bottom of the Seat Rail and threading into the Internal Seat Rail Bracket as illustrated.

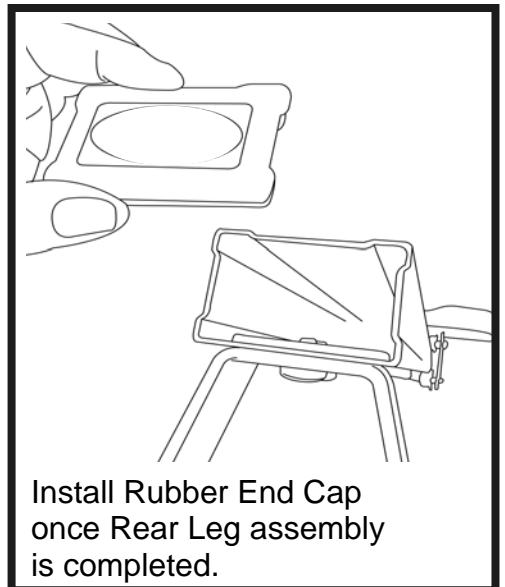
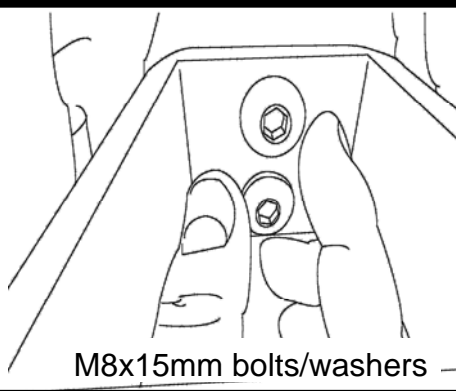

Installing the Seat Rail to Mainframe

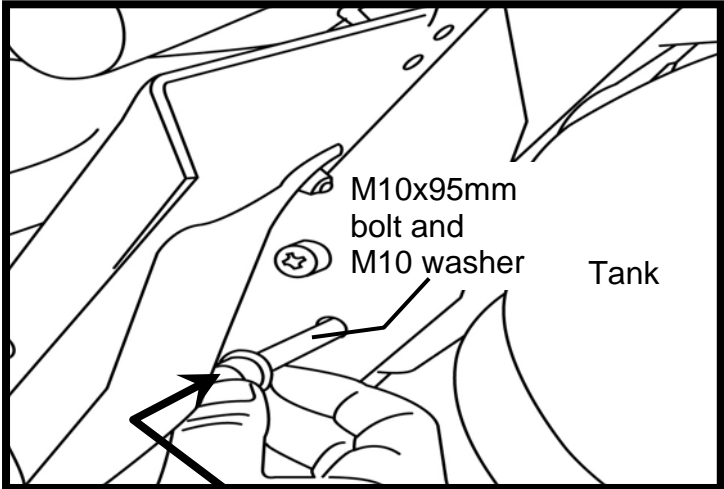
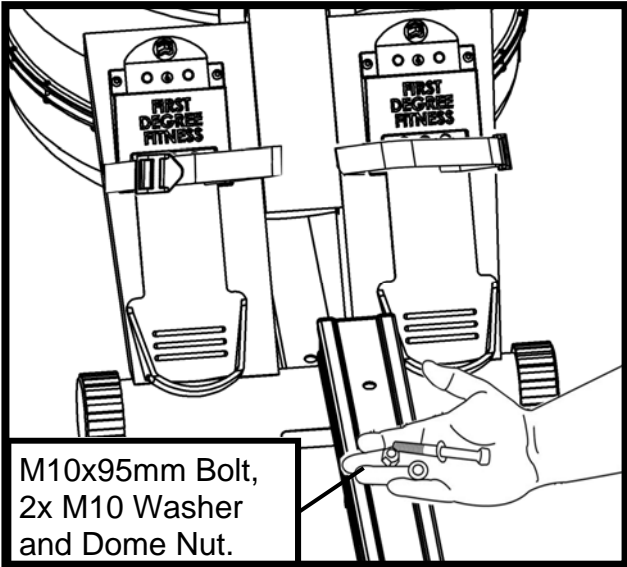

Insert the Seat Rail until it just slightly protrudes behind the Footplate. Shown here is the installation/alignment point for the M10x95mm Horizontal Seat Rail Bolt, M10 Washer and Dome Nut. Install and secure.

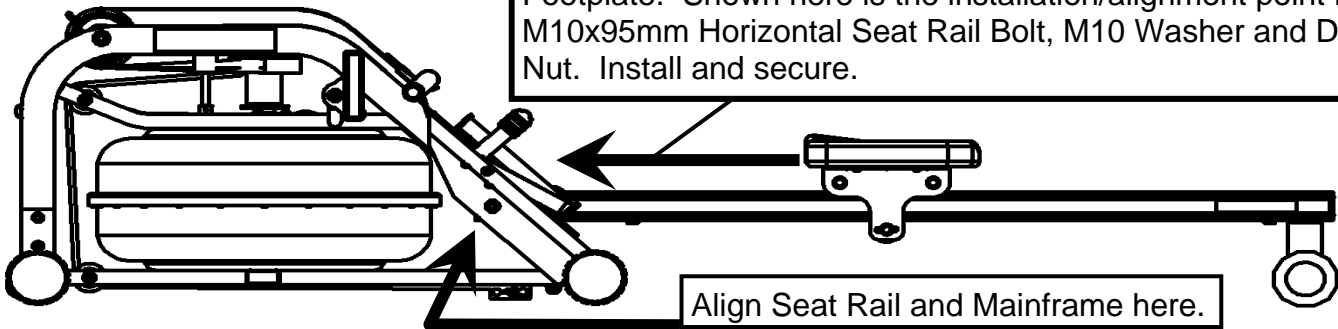

Installing the Vertical Seat Rail Tensioning Bolt

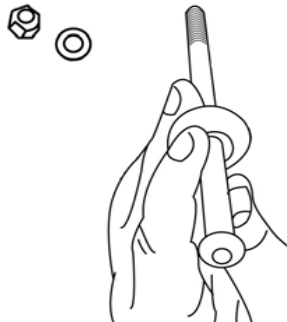
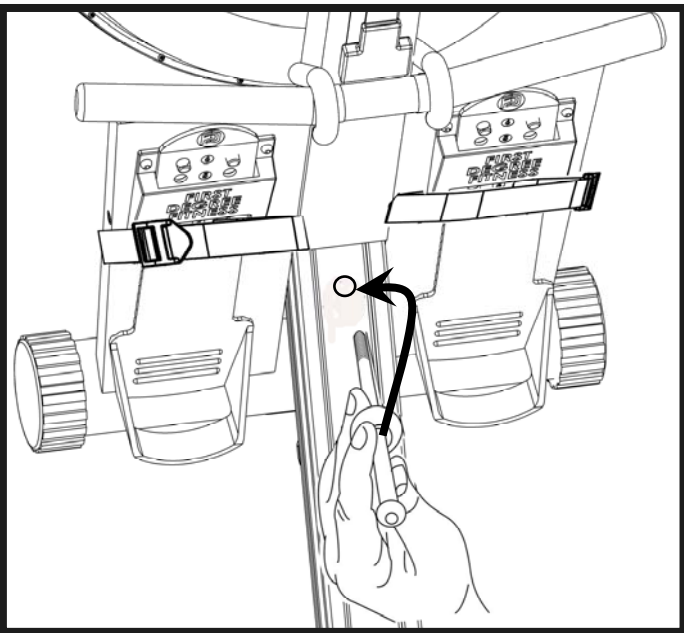

180mm Vertical Seat Rail Tensioning Bolt ,
Plastic Dome Cap,
M10 Nylock and M10 Washer.

Install the Vertical Seat Rail Tensioning Bolt and Plastic Dome Cap through the Seat Rail as shown, and secure from underneath with the M10 Nylock Nut and Washer.

Do not tighten. See following page for correct height adjustment.

Fine Tuning the Pacific Challenge AR:

The Vertical Seat Rail Tensioning Bolt is designed to hold the mid leg 3-5mm off the ground when the rower is un-weighted, and just slightly touch the ground during a rowing stroke.

Tighten the assembly until the Mid Leg begins to lift off of the ground as shown below.

If excessive head shaking/hopping occurs during rowing, the likely cause is the Vertical Seat Rail Tensioning Bolt being out of adjustment.

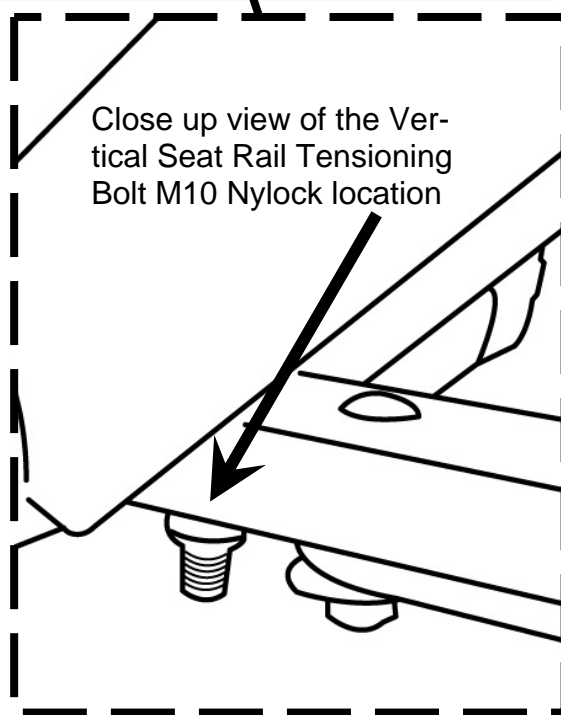
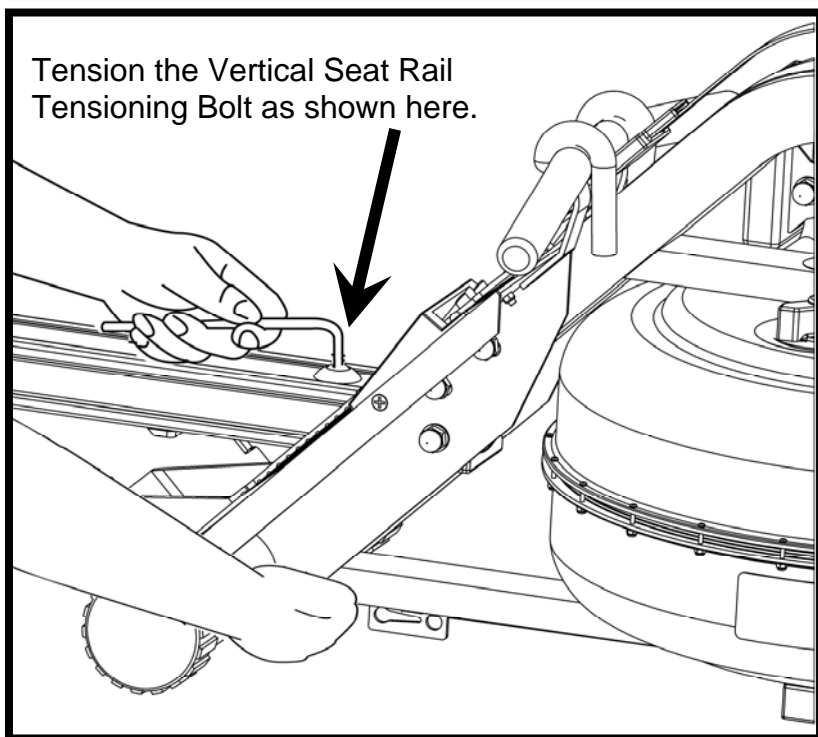
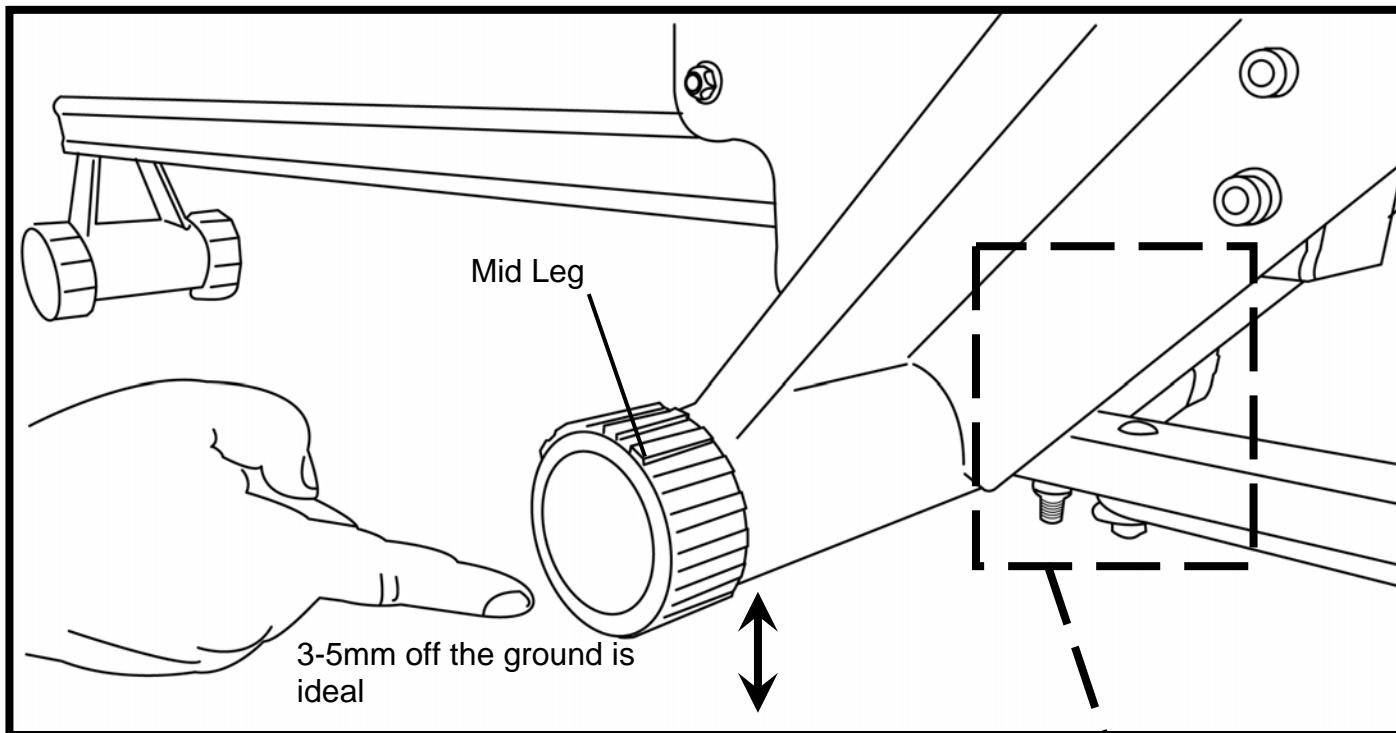

Adjustable Resistance (AR) Tank:

The Adjustable Resistance (AR) Tank, developed and patented by First Degree Fitness, offers a true multi-level experience. Water is moved between the "storage" and "active" chambers of the AR Tank. Your new Rowing Ergometer can adapt - at the turn of a dial - to the resistance preferred by each user in the home environment.

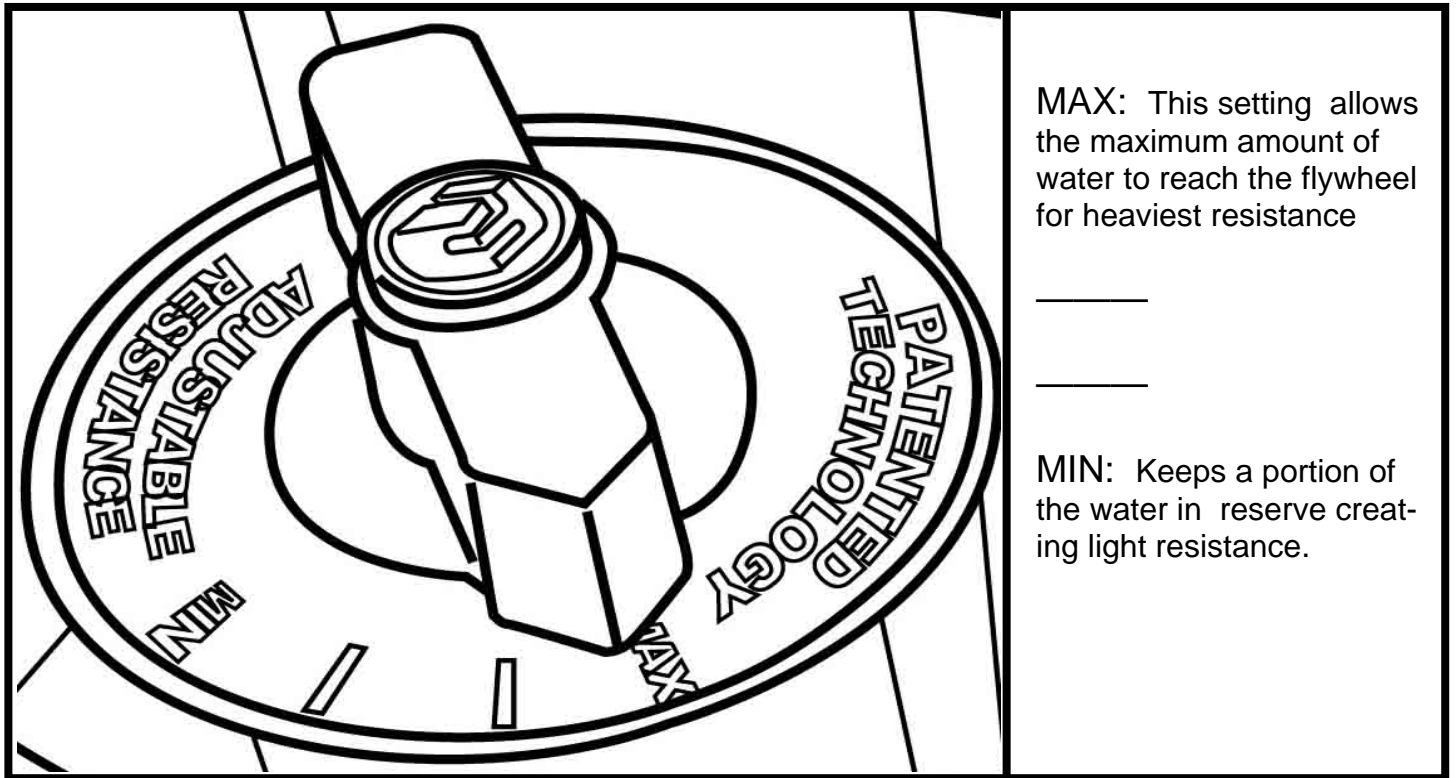

GETTING STARTED

To achieve minimum resistance, select "MIN" on the tank adjuster. It takes 10 strokes to fill the central (storage) tank, leaving a minimal amount of water in the outer (active) tank. This process is always required if minimum resistance is desired. Row hard at a steady pace (20 to 25 strokes per minute [SPM]) and put some effort into the stroke, ensuring that good form is maintained. You can make adjustments to the resistance level while you row. Your Rowing Ergometer will adapt almost instantly to increases in resistance but will take up to 10 strokes to reduce the effort required, as the central (storage) tank fills up.

DEVELOPING YOUR ROUTINE

Once you have found a level that gives you the exercise required, changes can be made to SPM and to stroke intensity to further vary your energy input. Interval training is used by most Rowers, where a period of low intensity is combined with short intervals of high intensity. Your FDF Rowing Ergometer allows for changes 'on the fly', to achieve multi-level resistance profiles during a single workout. For more information on exercise routines, please visit our website at www.firstdegreefitness.com

Note on Filling the AR Tank:



Important: Please Read Before Filling Tank:

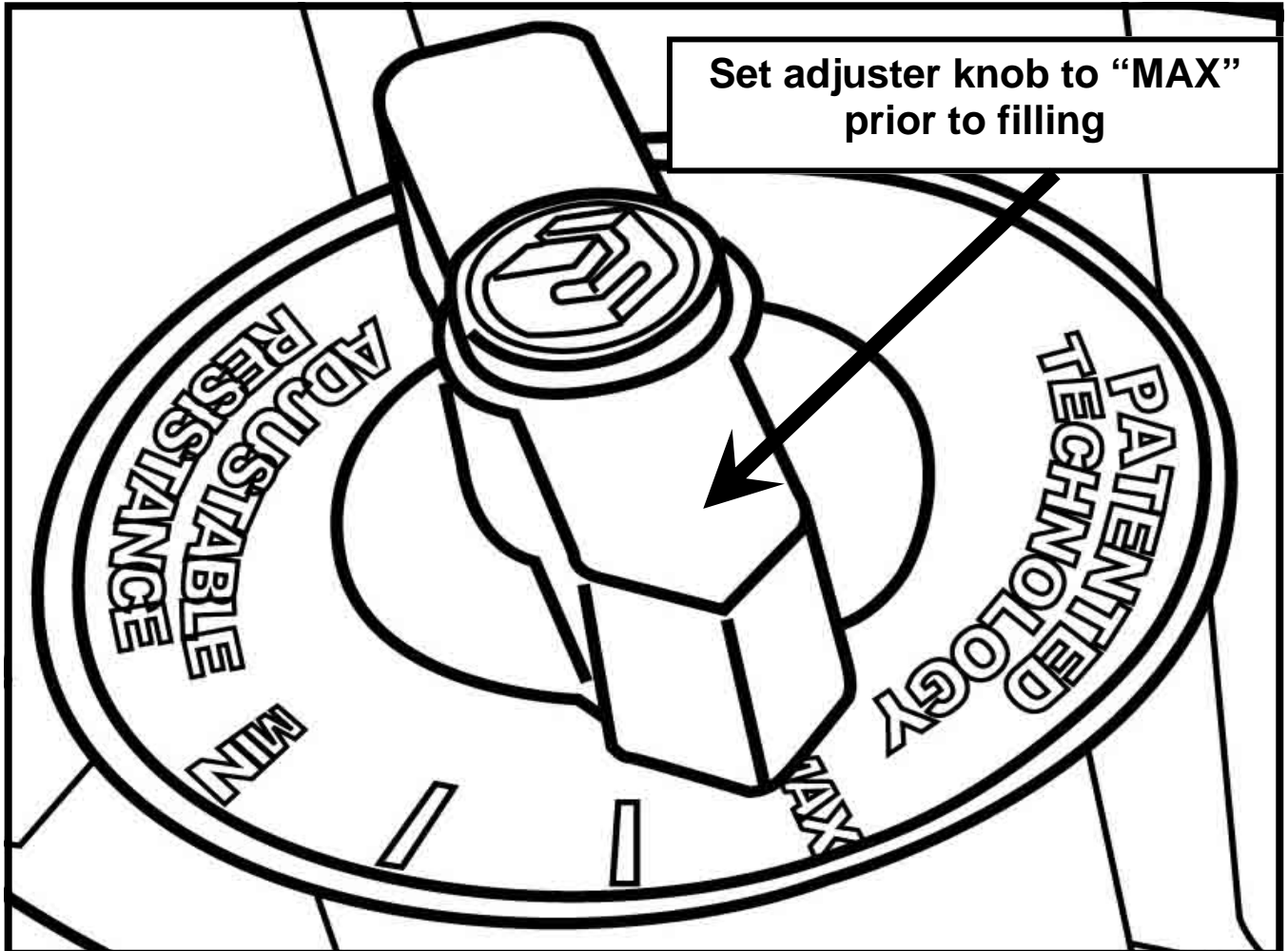

Caution:

When filling the AR tank, the **adjuster handle must be set to the "MAX" position as shown to allow accurate fill levels.**

Using any other setting other than "MAX" will result in inaccurate fill levels and in extreme cases could cause leakage to occur during use or when stored in the standing position.

DO NOT overfill the tank beyond the maximum indicated level of 17 litres. Refer to the Tank Level Decal on the lower side of the tank

Tank Filling and Water Treatment:

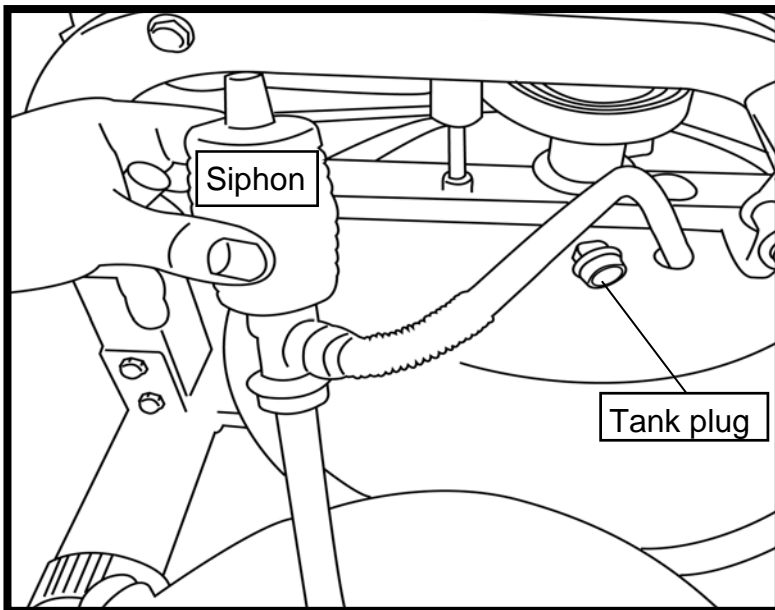

Tank Filling and Water Treatment Procedures

Note: 17 liters of water is required for maximum filling.

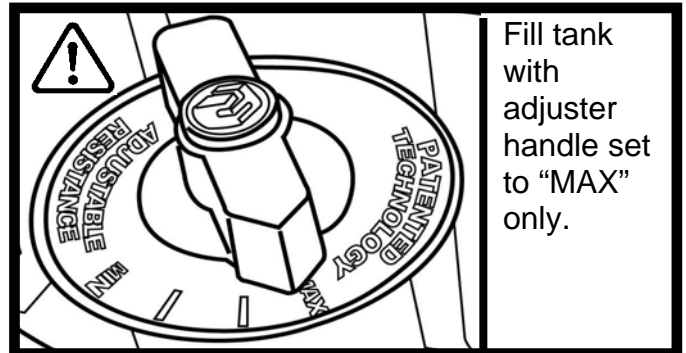

1. Remove Rubber Fill Plug from the top of the tank.
2. Place a large bucket of water next to the rower and position siphon with the rigid hose in the bucket and the flexible hose into the tank as shown. Note: Make sure small breather valve on the top of the siphon is closed before filling.

Note: Where water quality is known to be poor, FDF recommends the use of distilled water.

3. Begin filling tank by squeezing siphon. Use Level Gauge Decal on side of tank to measure volume of water in tank. Important: Do not overfill tank!
4. After filling tank to the desired water level, open the valve on the top of the siphon to allow excess water to escape.
5. Ensure that Tank Plug is replaced once filling and water treatment procedures are complete.

Tips on Siphon use: Putting the fill bucket higher than the tank will allow the siphon to "self-pump" when adding water to the tank.

Water Treatment Procedures:

1. Add Chlorine tablet.
2. Enough Chlorine Tablets are supplied for many years of Water treatment. Add a chlorine Tablet whenever the Water appears dirty or cloudy.

WARNING: Only use First Degree Fitness Supplied Water treatment tablets.

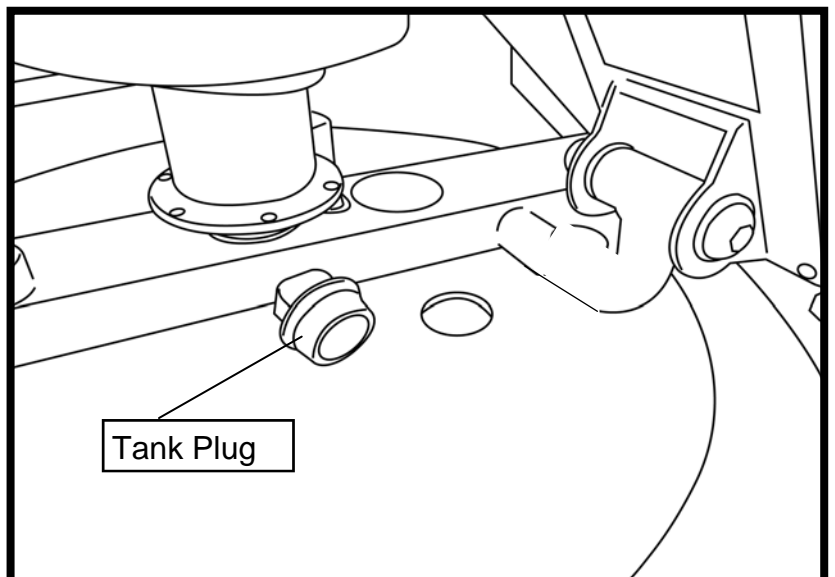

Caution:

Use a drop cloth under the tank both when filling the tank to avoid staining floor or carpet

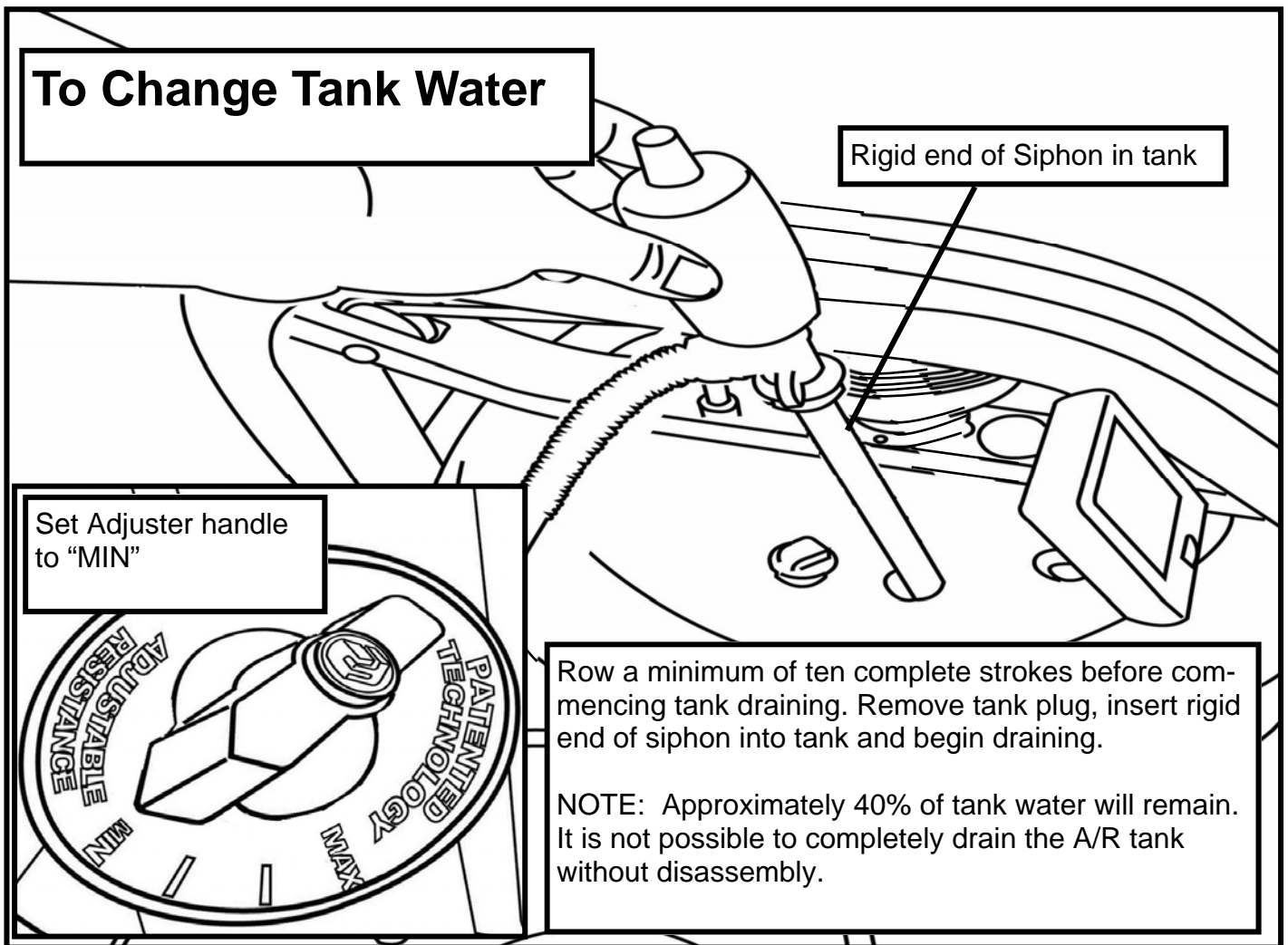

Removing/Changing Tank Water:

1. Set Adjuster handle to "MIN"
2. Row at least ten strokes to fill the storage reservoir as completely as possible.
3. Remove Tank Plug.
4. Insert rigid end of siphon into the tank, and flexible hose into a large bucket.
5. Drain tank (approx. 40% of water will remain) and then refill following directions for Tank filling as described in the Tank Filling section of this manual.

Note: The valve on top of the siphon must be closed to allow proper drainage.

Note: Water treatment will preclude the need to change tank water if the treatment schedule is maintained. Additional chlorine is required only when discoloration appears in the water.

Note: Exposure to sunlight affects the water. Moving the rower away from direct sunlight and adding the blue dye will extend time between water treatments.

Slider Footplate

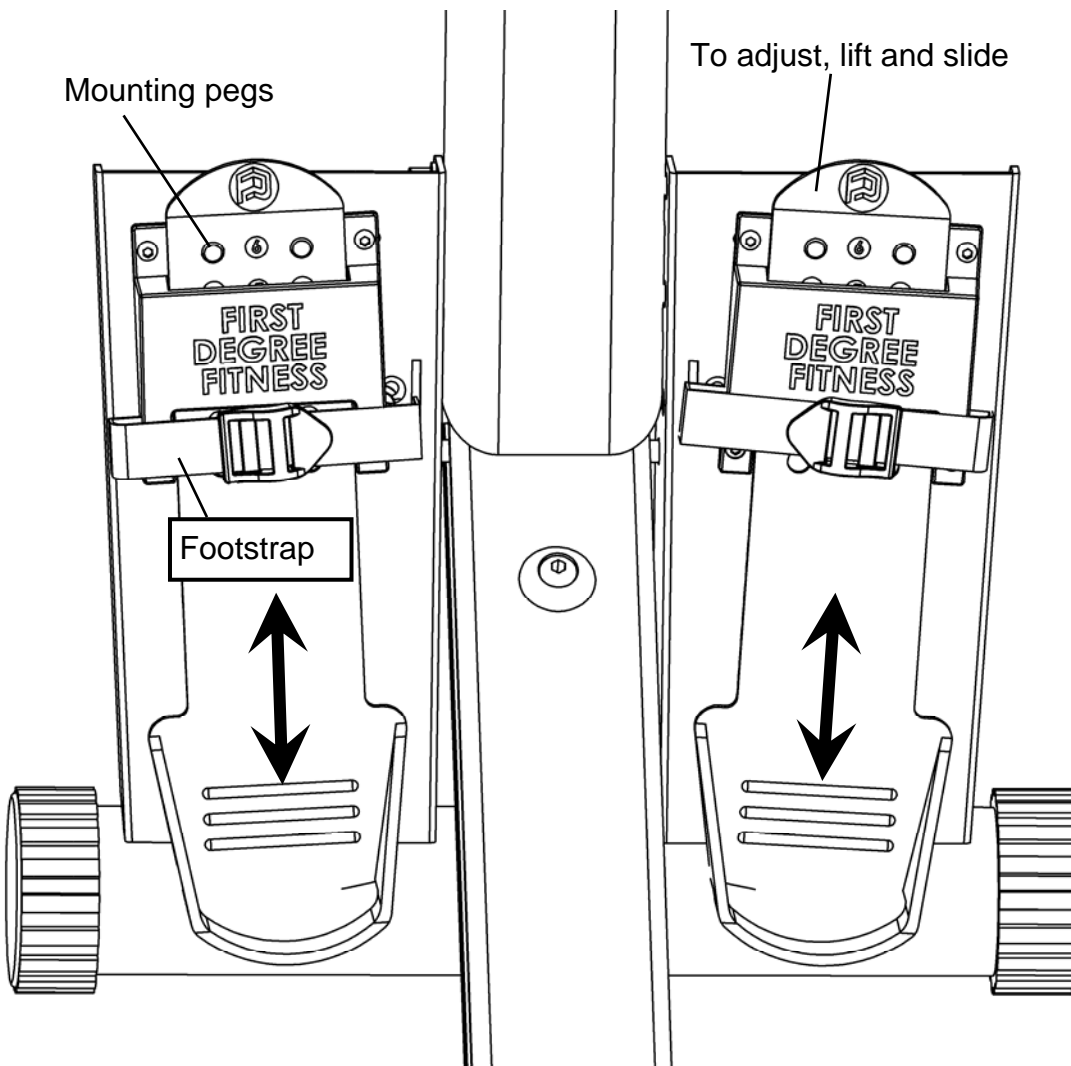

The Slider Footplate is designed to fit a wide range of foot sizes, and is very simple to use.

To adjust, lift the top of the sliding portion of the footplate and slide up or down. The numbers 1-6 represent a guideline from which the proper length can be determined. Secure the plate onto the mounting pegs and push down firmly to lock into position.

Tighten the Footstraps securely and begin your workout.



WARNING: Never operate this rower without feet properly secured in Footstraps, or without the sliding portion of the Slider Footplate locked into position!

How to Row?

1. Begin the stroke comfortably forward and push strongly back with your legs while keeping your arms and back straight.
2. Begin to pull your arms back as they pass over your knees and continue the stroke through to completion rocking slightly back over your pelvis.
3. Return to the starting position and repeat.

How Often?

Begin with 5 minute training sessions once a day and aim for around 2:30 to 2:45 for 500m time. Row at a pace that keeps the water circulating continuously between strokes.

Progress a few minutes more each day until you are comfortable with 30-45 minutes training time 3 or 4 times a week.

This will provide aerobic endurance benefits, muscle toning and sufficient calorie burning to form part of a weight loss program.



CAUTION

Always consult a doctor before beginning an exercise program.

Stop immediately if you feel faint or dizzy.

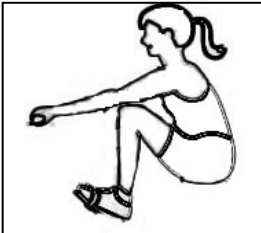
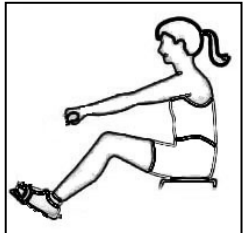
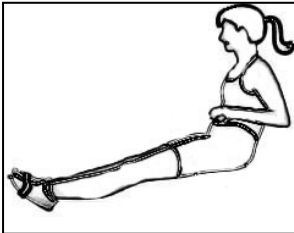
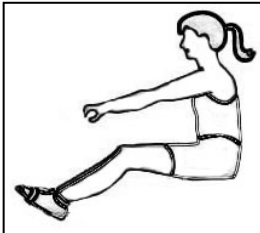
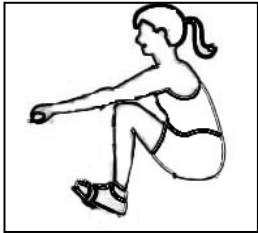
				
<p>Catch Comfortably forward with straight back and arms.</p>	<p>Drive Push with the legs while arms remain straight.</p>	<p>Finish Pull through with arms and legs rocking slightly back on your pelvis.</p>	<p>Recovery Upper body tips forward over your pelvis and move forward.</p>	<p>Catch Catch and begin again.</p>

The Trident Challenge AR Computer:



Options:

Auto Start: Commence rowing to activate.

Hold button down for 3 second first to RESET.

Add 1000m distance each button push to accumulate required distance then begin rowing to initiate count-back.

Auto-Pause: A temporary halt in exercise will result in the following:

For over 5 seconds and under 5 minutes:

SPM/500METER/WATT to zero. Distance/TIME values are saved. CAL per hour defaults to Total CAL.

A Resumption in exercise in less than 5 minutes will resume Distance/TIME/ from saved values automatically.

Auto Power Down: Over 5 minutes. All values revert to zero after restart.

Computer Instructions:

TIME: Auto start elapsed time.

500M TIME: Time to row 500 meters, updated at the completion of each stroke.

PULSE: Requires optional receiver and chest strap (sold separately).

SPM: Strokes per minute updated each stroke.

CAL HOUR: Updated each stroke.

WATT: Unit of power updated per rowing stroke.

LEVEL UP/DOWN: Use the LEVEL UP/ DOWN buttons in conjunction with the Fluid Tank Resistance Adjuster handle for accurate 500M/Distance/CAL/WATTS.

MAX: Level 4



MIN: Level 1

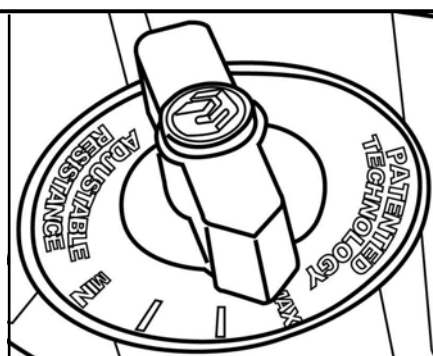

Using the First Degree Fitness USB Interface

(Option)

Description:

The USB connectivity now built in to all new models of FDF Console and IPM allow you to enhance your exercise experience by connecting to your home PC or Laptop. Using FDF's own sample applications you can exercise while enjoying your favorite movies. *NetAthlon 2 XF for Rowers* lets you race with other Internet connected rowers in a Virtual Reality 3D environment or train solo.

Setting up USB connectivity

1. Download and Install the USB Device Driver (CDM2xxxx_Setup.exe for 32 and 64 bit Windows 7/Vista/XP) from the FDF Website.
2. Download and Install the Sample USB Applications from the FDF Website (www.firstdegreefitness.com).
Download and Install NetAthlon 2 XF for Rowers from <http://www.webracing.org/downloads.htm>

Connecting your console

- The USB Connector is located on a flying lead at the rear of the IPM, along with the Sensor and Heart Rate Monitor Connectors.
- Connect to a Laptop or PC using a standard USB cable, you may need to wait while Windows starts the USB Device Driver.

Note: Please refer to computer manual where applicable or for further information refer to our website at www.firstdegreefitness.com

Detaching the Rower Belt:

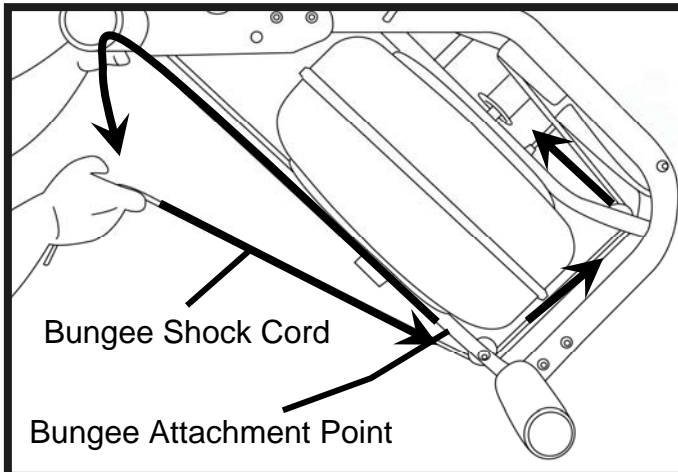

1. To detach belt, simply pull beyond the range of the normal rowing stroke until the belt detaches from the Belt Bungee Pulley.

Tip: You'll hear the Velcro separating just before the belt detaches.

2. Cut plastic tie holding bungee at the Bungee Attachment Point, pull the Cord through all three pulleys and leave excess on top of the tank for now.

Reattaching the Rower Belt:

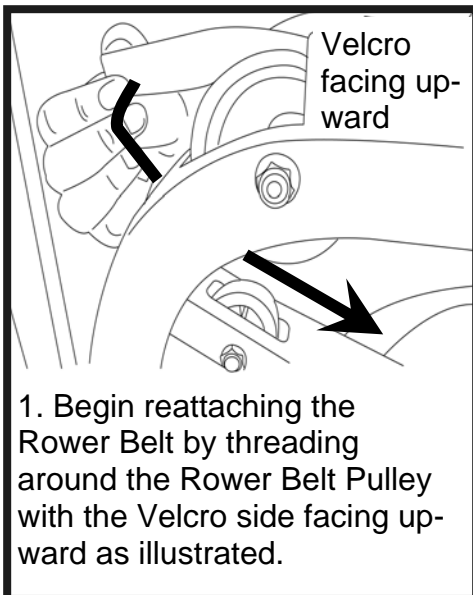

1. Begin reattaching the Rower Belt by threading around the Rower Belt Pulley with the Velcro side facing upward as illustrated.

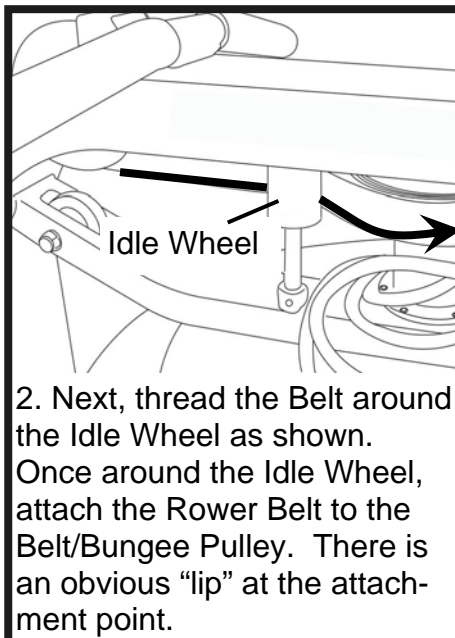

2. Next, thread the Belt around the Idle Wheel as shown. Once around the Idle Wheel, attach the Rower Belt to the Belt/Bungee Pulley. There is an obvious "lip" at the attachment point.

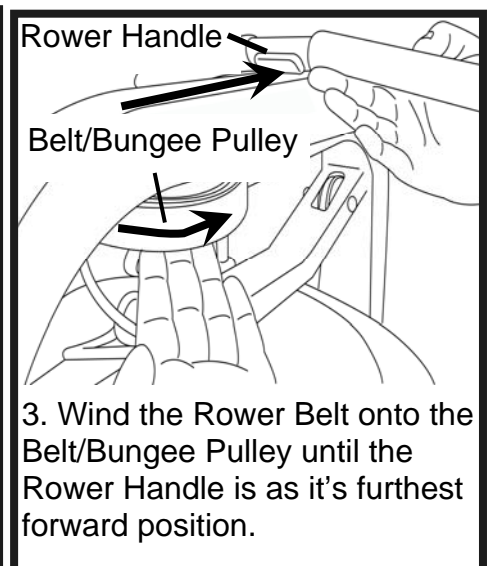

3. Wind the Rower Belt onto the Belt/Bungee Pulley until the Rower Handle is as it's furthest forward position.

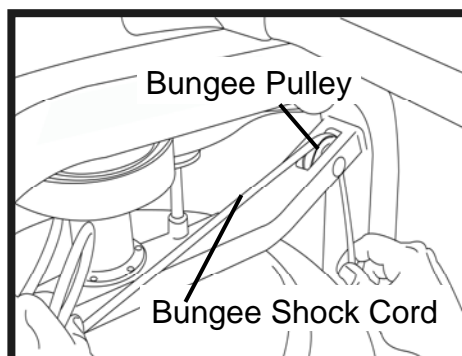

4. Rethread the Bungee Shock Cord (on opposite side of the Idle Wheel) back through the Bungee Pulleys and tie off at the Attachment Point.

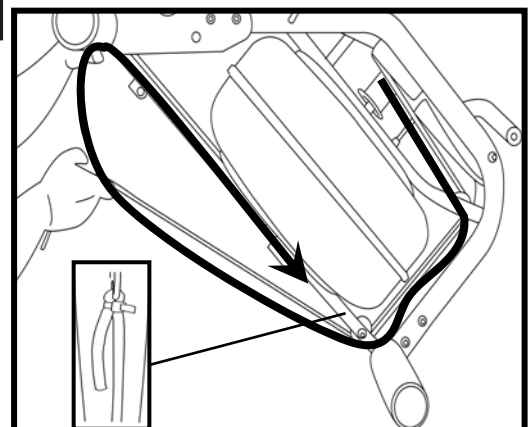

Hint:

If Bungee Shock Cords previous tension seemed correct (a good way to judge is if the Rower Handle can make it to the furthest point forward on the top of the Mainframe under bungee tension alone) then simply tie off at previous position. If the return is too slack, experiment by tightening the tension in small increments and testing until the correct tension is achieved. If the Rower Handle cannot reach the end of the seat rail during a rowing stroke, then the Bungee Shock Cord is over-tensioned.

Removing the Bungee Shock Cord:

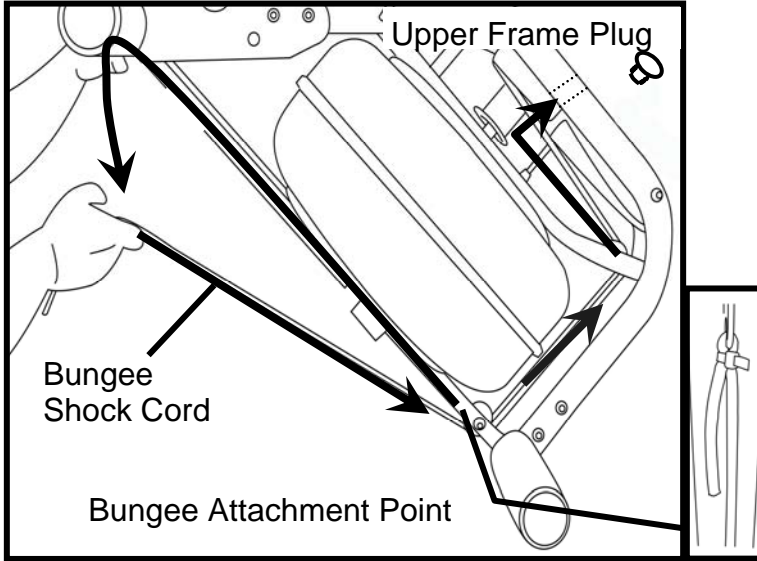

First, move the Rowing Handle to its farthest forward point on the Mainframe, then cut the plastic end tie and follow the drawing above for bungee removal. Next, remove the Upper Frame Plug to allow the Bungee Shock Cord to be threaded through the top of the frame. Note: You will need to rotate the Belt/Bungee Pulley to align the holes properly. Should the belt drop off of during the bungee change, please refer to the previous pages for "Attaching/Reattaching the Rower Belt".

Once Bungee Cord and Upper Frame Hole are aligned, push the Bungee Cord up and through the frame as shown



In areas where tap water quality is known to be poor, FDF recommends the use of distilled water.

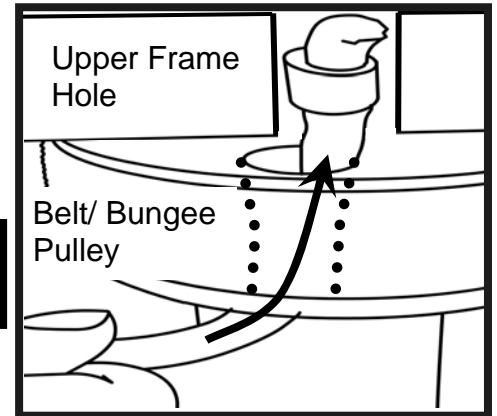

Replacing the Bungee Shock Cord:

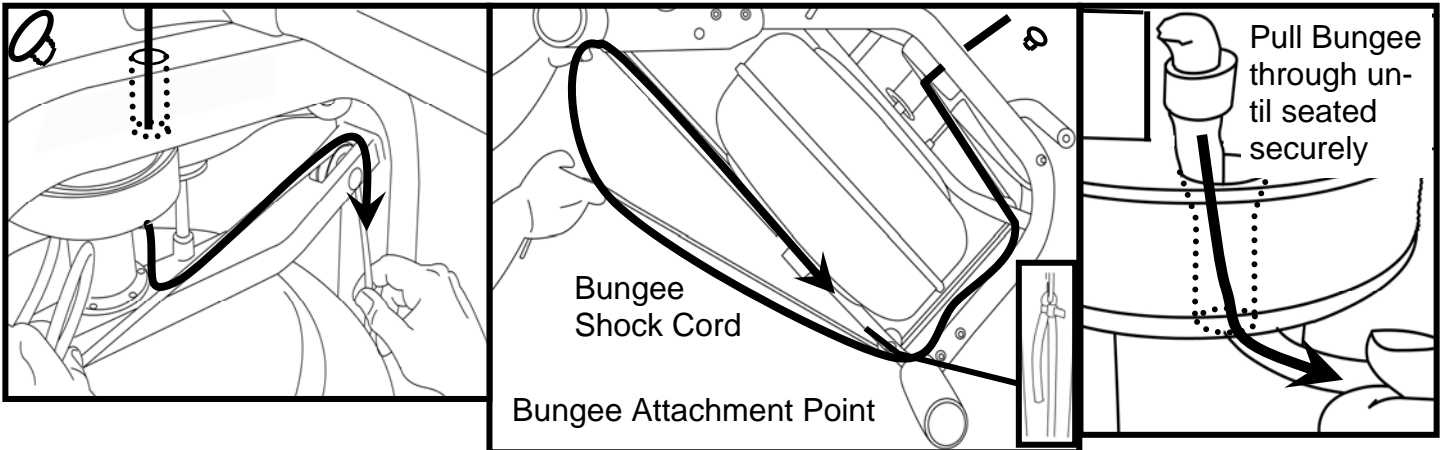

Reinstall the Shock Cord through the Upper Frame, along the opposite side of Idle Wheel, through the Mid Frame and Lower Bungee Pulleys and then tie off with plastic tie wrap to correct tension. Replace Frame Plug.



Tip: Correct bungee tension is achieved when enough recoil is present for the Rowing Handle to easily reach the front of the Rower Pulley Belt Bracket at the far front of the frame. If the Rowing Handle will not reach rearward to the end of the Seat Rail, the Bungee Cord is over-tightened and will require adjustment.

Troubleshooting:

Fault	Probable Cause	Solution
Water changes color or becomes cloudy.	Rower is in direct sunlight or has not had water treatment.	Change rower location to reduce direct exposure to sunlight. Add water treatment and blue dye or change tank water as directed in the water treatment section of this manual.
Rower belt slipping off belt/ bungee pulley.	Bungee not under enough tension.	Tighten bungee cord following the instructions in "Replacing the Bungee/Shock Cord" section of this manual.
Front of rower lifts slightly during vigorous rowing.	M10X180mm Vertical Seat Rail Tensioning Bolt is slightly too loose.	Tighten bolt 1/2 turn and row again. Tighten as needed until problem stops. Note: Over tightening this bolt can damage the seat rail. Only tighten bolt in small increments until fault is corrected.
The Pacific Challenge AR computer does not illuminate after battery installation.	Batteries installed incorrectly or need replacing.	Reinstall batteries in correct position and try again. If the LCD screen fails to illuminate, try rotating the batteries slightly in the computer. If this fails, contact your local service center.
Pacific Challenge AR Computer screen illuminates, but does not register when rowing.	Loose or failed connection.	Check that the computer lead is connected properly. If it is connected then contact your local service center.

Parts List

Part #	QTY	Description	Part #	QTY	Description
10036	12	Grub Screw M3x20 SUS	60615	1	Bungee Cord 8mmx1950 & Clip #60617 & Tie #61008
10041	1	Nut Nylock M10	60616	1	Frame Spacer Internal
10052	1	Grub Screw M4x6	60702	4	Seat Wheel
10081	4	Washer M6	60705	4	Seat Wheel Short Spacer
10082	5	Washer M10	60706	2	Inner Axle Bushing Long 52.5mm
10097	7	Nut Dome Head M10	60707	3	Bolt M8x120
10129	1	Decal - How to Row	60709	3	Nut Nylock M8
10139	8	Spring Washer M10	60710	4	Washer M6x11
10176	2	Foot Strap with Buckle	60711	4	Screw M6x20
30608	8	Nut M5 Nylock	60801	1	Seat Rail with Decal
60100	1	Upper Main Frame	60802	1	Rear Leg Internal Mounting Plate
60108	4	Bungee Pulley Spacer	60803	2	Rubber Bump Stop - Seat Rail
60109	2	Bungee Pulley	60804	2	Seat Rail End Cap 75x75
60110	2	Belt Pulley Spacer	60805	2	Rear Leg Adjustable Height End Caps
60111	1	Belt Pulley 100mm (inc. 2x60112 Bearing)	60806	1	Bolt M10x180
60112	4	Belt pulley bearing 6000ZZ	60807	4	Bolt M6x10
60113	1	Main Shaft Oil Bushing - Lower	60808	2	Screw M8x15
60114	1	Magnet Ring (inc. 6x60124 Magnet)	60809	1	Plastic Dome Cap 10mm
60115	1	Flywheel Shaft spacer	60812	4	Decal—Pacific Challenge AR
60119	1	Idle wheel inc. 2x60112 Bearing	60900	1	Bungee/ Belt Pulley complete
60120	1	Roll Pin 6mm	60903	1	Velcro Strip
60121	1	Bolt M10x90	61001	4	Tank Bonding Strip 3M-VHB
60123	1	Idle Shaft Upper Frame Mount 10mm	61002	2	Heel Adjuster Decal
60124	6	Rare Earth Magnet 5mmx4mm	61003	2	Main Frame Side Decal
60125	1	Idler Pulley Shaft	61004	1	Main Frame Upper Warning Decal
60126	2	C Clip 10mm	61007	1	Main Frame Lower Warning Decal
60128	2	Bolt M8x65	61063	2	Footplate Slider
60129	2	Nut Dome Head M8	61064	2	Footplate Slider Base
60130	2	Frame Rubber Bumper	61067	8	Screw M5 x 15
60131	1	Tank Outer Rubber Protection Ring	62001	1	Rubber Pulley Cover
60132	24	Screw M3x20	63118	1	Tank Large Ring Seal - Yellow
60133	24	Nut Nylock M3	63144	1	Tank Plug
60135	5	Bolt M10x95	64141	1	Computer with USB - AR
60137	1	Tank/Mainframe Impeller Shaft Spacer	65121	2	Seat Frame Bracket
60138	1	Impeller End Cap	65944	1	Decal - Tank Level
60139	3	Tank Internal Screw S/Steel M6x15	65971	1	Impeller - AR
60140	2	Computer Mount Plastic Bushing	65980	1	Lower Tank Shell
60142	1	Bolt M10x60	65981	1	Upper Tank shell—Outter
60143	1	Sensor	65982	1	Inner Reserve Tank Shell / AR
60147	2	Washer O Ring 9.5x6.5x1.5mm	65983	1	Tank adjuster outer cup
60148	1	Computer Heart Rate Lead	65984	1	Tank adjuster inner cup
60150	1	Main Shaft Nylon Bushing - Upper	65985	1	Decal - AR Resistance
60200	1	Lower Frame	65986	1	Adjuster Knob
60209	4	End Cap 75mm Round	65991	1	End cap-Adjuster Knob
60210	4	Transport Wheel Fastener	65992	4	Grub Screw M3x12 SUS
60211	2	Transport Wheel 76.2	90104	2	Rubber Hook Cover
60212	2	End Cap 25x50mm	90136	2	INA One Way Bearing 2016
60400	1	Rear Leg	90707	1	Lower Seat Wheel Axle Spacer 102mm
60500	1	Rower Handle Complete			

PACIFIC CHALLENGE AR ROWER

INTERNATIONAL WARRANTY – HOME USE

First Degree Fitness Limited warrants that the **Pacific Challenge AR (model PACAR)**, purchased from an authorised agent and in its undamaged original packaging, is free from defects in materials and workmanship. First Degree Fitness Limited or its agent will, at their discretion, repair or replace parts that become defective within the warranty period, subject to the specific inclusions and exclusions below.

Metal Frame – 5 Year Limited Warranty

First Degree Fitness will repair or replace the metal Main Frame of the Rower should it fail due to any defect in materials or workmanship within 5 years of the original purchase. Warranty does not apply to frame coating.

Polycarbonate Tank & Seals – 3 Year Limited Warranty

First Degree Fitness will repair or replace the polycarbonate tank or seals should they fail due to any defect in materials or workmanship within 3 years of the original purchase.

Mechanical Components (of a non-wearing nature) – 2 Year Limited Warranty

First Degree Fitness will repair or replace any mechanical component should it fail due to any defect in materials or workmanship within 2 years of the original purchase.

Specific Inclusions

- Aluminum Seat Rail
- Stainless Steel Impeller Assembly

All Other Components (of a wearing nature) – 1 Year Limited Warranty

First Degree Fitness will repair or replace any component should it fail due to any defect in materials or workmanship within 1 year of the original purchase.

Specific Inclusions

- Bungee recoil cord
- Hand grips & foot straps
- Polyester rowing belt
- Seat
- All pulleys, rollers & bearings
- All rubber components
- Computer & speed sensor (excluding replaceable batteries)
- Footplates (pivoting & sliding)

General Exclusions

- Damage to the finish of any part of the machine
- Damage due to neglect, abuse, incorrect assembly or use of the machine
- Any charges for freight or customs clearance associated with the return or dispatch of parts
- Any damage to or loss of goods during transport of any kind
- Any labour cost associated with a warranty claim

General Conditions

- The serial number of the machine must be correctly registered with First Degree Fitness Limited or one of its appointed distributors
- First Degree Fitness Limited reserve the right to examine any part where replacement is claimed under warranty
- Warranty period applies only to the original purchaser from the date of purchase and is not transferable
- The product must be returned to your place of purchase in original packaging with transportation, insurance and associated charges paid for by you and risk of loss or damage assumed by you
- First Degree Fitness makes no other warranties except as stated here and expressly disclaims all warranties not stated in this warranty. Neither First Degree Fitness nor its associates shall be responsible for incidental or consequential damages
- Manufacturer's warranty automatically commences upon sale of the product to end user or upon the expiration of one (1) year from month of manufacture, whichever occurs first