

OWNER'S MANUAL



VRC500-SDU

AM/FM Receiver, CD/MP3/WMA Player with
SD Card Slot, USB Port, Aux In, & Detachable Face

- AM/FM MPX STEREO
- MP3 / WMA WITH ID3 DISPLAY
- F/PS MEMORY CONTROL
- AUTO SEEK UP / DOWN
- FM STEREO / MONO
- 30 PRESET MEMORY
- VOL/ BAS / TRE / BAL / FAD
- AUTO CD PLAY / RADIO
- LOUDNESS CONTROL
- MUTE SOUND CONTROL
- USB PORT
- SD CARD SLOT
- WIRE HARNESS ON PLUG
- DIGITAL LCD DISPLAY
- DUAL CHANNEL LEVEL METER
- TIME CLOCK DISPLAY
- PRESET EQ (POP, ROCK, FLAT, CLASSIC)
- BUILT IN NOISE FILTER
- BUILT IN RCA OUTPUT
- SUBWOOFER OUTPUT
- AUXILIARY INPUT
- AUTO ANTENNA ACTIVATOR
- INFRA RED REMOTE CONTROL



Welcome!

Dear Customer,

CONGRATULATIONS. The VRCD500-SDU Compact Disc Player and AM/FM Stereo Receiver with SD Card Slot, USB Port and AUX In, when used as described, will give you years of dependable service in your car, truck, RV, or mini-van. We have taken numerous measures in quality control to ensure that your product arrives in top condition and will perform to your satisfaction. In the rare event that your VRCD500-SDU Compact Disc Player and AM/FM Stereo Receiver with SD Card Slot, USB Port and AUX In contains a damaged or missing item, does not perform as specified, requires warranty service, or you have an installation problem, **DO NOT RETURN THIS PRODUCT TO THE STORE. PLEASE CALL OUR TOLL FREE NUMBER FROM THE U.S.A. AND CANADA 1-800-445-1797** and ask to speak with a member of our technical service team; or submit your questions by e-mail to customerservice@vr-3.com and a member of our technical service team will respond by e-mail to your questions. Our in-house technical service team will expedite delivery of your part, advise you on installation, or help troubleshoot a problem with you. If your product needs warranty service, our technical service team representative will help you obtain the fastest remedy possible under the warranty.

Contents

Precautions	2
Notes on Installation	3
Before You Install.....	4
Installation (DIN Front Mount)	5
Installation (Vehicle's Brackets).....	6
Parts.....	6
Wiring Connections.....	7
Location of the Controls	8
Remote Control	9
Basic Operation.....	10-11
Radio Operation	12
CD Operation	13
MP3/WMA Operation (CD).....	14-15
USB Operation	16
SD Memory Card Operation	17
AUX IN, RCA, & Subwoofer Control	18
Simple Troubleshooting Guide	19
Specifications	20
Warranty	21

Precautions

- This unit will only play the following discs.

Type of disc	Label on the disc	Recorded material	Size of disc
CD, MP3, & WMA		Audio only	12 cm

- Do not attempt to modify the unit.
- Modifying the unit will void the warranty.
- Stop the vehicle before carrying out any operation that could interfere with your driving.
- Do not operate in extremely high or low temperatures. The temperature inside the vehicle should be between 32° F (0° C) and 100° F (37° C) before turning on your unit.

Care of Discs

- Handle the disc by its edge to keep the disc clean. Do not touch the disc's surface.
- Do not use CDs with labels or stickers attached. The label may leave a sticky residue when it begins to peel.

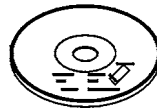

- Do not use a CD with paste or ink residue on it.



- Clean the discs with an optional cleaning cloth. Wipe each disc from the center out.



Notes on Installation

- Disconnect negative battery terminal before starting installation. Consult the vehicle's owner's manual for proper instruction.
- The unit is designed for a 12Volt DC negative ground operation system only. Before installing the unit, make sure your vehicle is a 12Volt DC negative ground system.
- Mark the polarity of the existing speaker wires before disconnecting the old unit.
- Be sure to connect the color coded leads according to the diagram. Incorrect connections may cause the unit to malfunction or damage the vehicle's electrical system.
- Make sure all the connections are completely correct before turning on your unit.
- When extending the ignition, memory backup or ground cable, use diameter of 0.75mm (AWG18) or more automotive grade cable to avoid wire deterioration or damage to the wire coating.
- To prevent short circuit, never put or leave any metallic object inside the unit. If you smell or see smoke, turn off the power immediately and consult your dealer.
- Insert the unit until it is firmly locked into mounting sleeve, otherwise it may fall out.
- Be careful not to drop or shock the unit, it may break or crack because it contains glass parts.
- The unit is only designed for use with 4 speakers. Do not combine output for use with 2 speakers. Do not ground negative speaker leads to the chassis ground.
- Do not open the top or bottom cover and do not install the unit in a place where it is exposed to direct sunlight (including faceplate), high heat, humidity, moisture, or dust.
- The faceplate is a precision piece of equipment that contains sensitive electronic components. Do not subject it to excessive shock.
- When replacing the fuse(s), the replacement must be of the same amperage as shown on the fuse holder.
- Do not block vents or heater panels. Blocking them will cause heat to build up inside and may result in fire.
- After completing the installation and before operating the unit, reconnect the battery. Then press the (RES) button with a pointed object, such as a ball-point pen to set the unit to its initial status.
- Do not touch the terminals of the faceplate or of the unit.
- If you have difficulty installing this unit in your vehicle. Please contact your dealer.

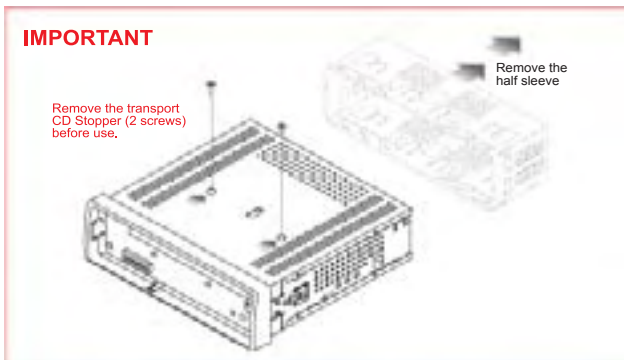

Before You Install

Automotive audio equipment installations can be troublesome at times, even to the most experienced of installation technicians. If you are not confident working with electrical wiring, removing and reinstalling interior panels, carpeting, dashboards or other components of your vehicle, please call our toll-free help line 1-800-445-1797 and our in-house technical service team will answer your installation questions. Contact the vehicle's manufacturer for vehicle specific instructions, or consider having the VRCD500-SDU professionally installed.

IMPORTANT: Remove the two transport screws from the top of the unit before installing.

1. Remove the Old Unit from the Dashboard

A. Remove the outer trim frame.

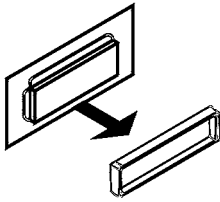

DIN Front Mount

B. Insert the keys supplied with the old unit into both sides of the unit as shown in figure below until they click. Pull to remove the old unit from the dashboard.

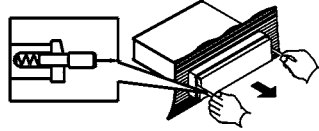

DO NOT DISCONNECT WIRES AT THIS TIME!

2. Mark Polarity of the Speaker Wires

Marking the polarity of the speaker wires will make it easier to connect the existing speakers to the VRCD500-SDU. Consult wiring diagram of existing head unit before disconnecting any wires. If a wiring diagram is not available contact the manufacturer.

1. While the old unit is playing, disconnect the wires from one speaker.
2. Take a length of masking tape and fold it around the wire so it forms a flag.
3. On the masking tape mark the polar-

ity of the speaker wires (+ & -), as well as left or right, and front or rear.

4. Double check that you marked the first speaker correctly by checking that the speaker wires are the same at the head unit.
5. Repeat this procedure for all of the speakers.
6. Mark the power, ground, and any other wires also.

INSTALLATION

DIN FRONT-MOUNT (Method A)

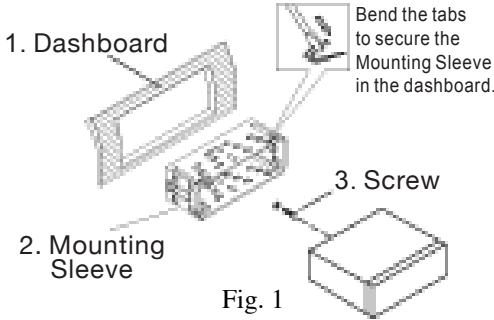

After inserting the Mounting Sleeve into the dashboard, select tabs on top, bottom, and sides, then bend them to secure the mounting sleeve in the dashboard.(Fig. 1)

Follow the diagram in Fig. 2 for installing the rear mounting strap to the head unit. The rear mounting strap will help keep the head unit from moving around inside the dashboard.

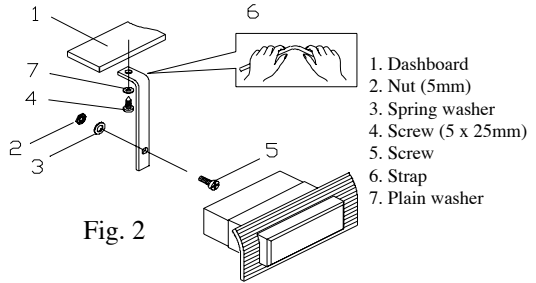

Insert fingers into the groove in the front of frame to remove it.

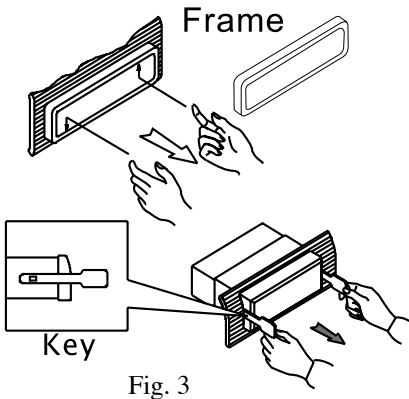

Insert the keys supplied with the unit in the grooves on both sides. The unit can be installed or removed from the dashboard using these keys.(Fig. 3)

INSTALLATION

DIN REAR-MOUNT (Method B)

Installation using the screw holes on both sides of the unit.

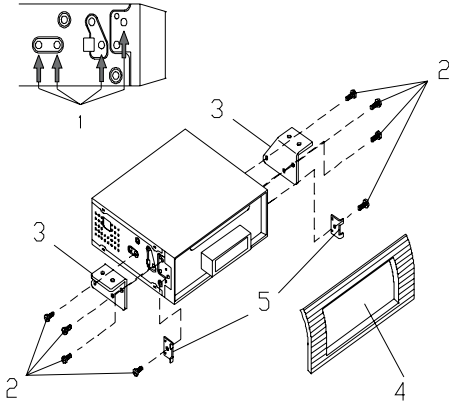

1. Screw holes on the side of the unit.
2. Screws. Use either truss screws (5 x 8mm) or flush surface screws (4 x 8mm), depending on the shape of the screw holes in the bracket.
3. Vehicle's Factory Mounting Bracket
4. Dashboard or Console
- 5 Hook (Remove this part)



Note: The mounting sleeve, outer trim ring, and the mounting strap are not used for this method of installation.

PARTS

- 2 Keys
- 1 Hex Nut
- 2 Lock Washers
- 1 Sheet Metal Screw
- 1 Metal Support Strap
- 2 Flat Washers
- 1 Mounting Bolt
- 1 Faceplate Case (not shown)
- 1 1/8" Stereo Cable
- 1 Remote Control



INSTALLATION

WIRING CONNECTIONS

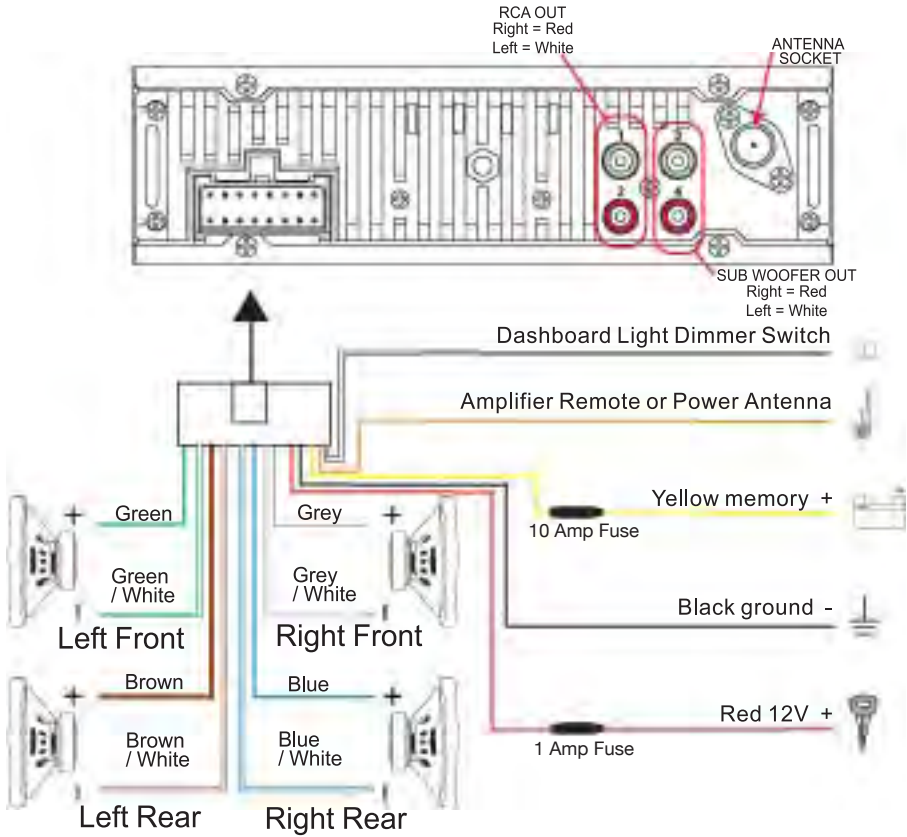

Location of the Controls

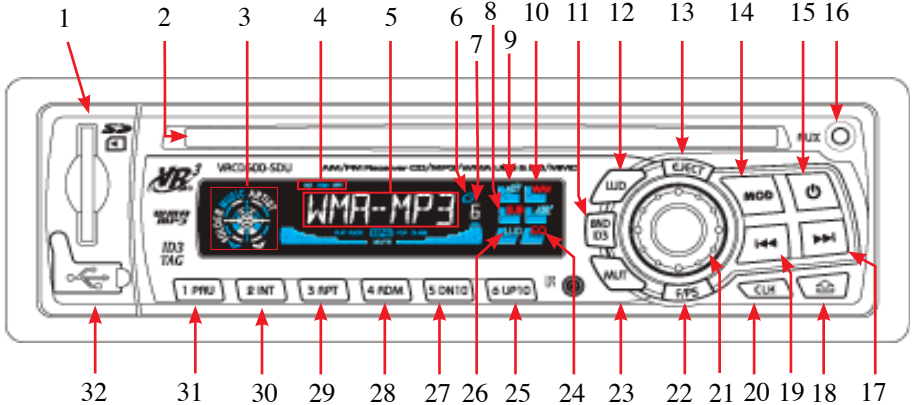

1. SD Card Slot
2. Disc Slot
3. ID3 Display Indicator
4. Intro, Random, & Repeat Function Indicators
5. Main LCD for Track Number, Time, & Radio Frequency
6. FM Stereo Indicator
7. Number of Stored Pre-set for AM/FM Bands
8. Subwoofer ON Indicator
9. MP3 File Indicator
10. WAV File Indicator
11. Band/ID3
12. Loudness
13. Eject
14. Mode Button
15. Power Button
16. Auxiliary In
17. Next Track/Change Frequency/Fast Forward
18. Faceplate Release
19. Previous Track/Change Frequency/Fast Reverse
20. Clock
21. Volume Knob
22. Automatic Scan & Store
23. Mute
24. Equalizer ON Indicator
25. Pre-set #6/ UP 10
26. Loudness ON Indicator
27. Pre-set #5/ Down 10
28. Pre-set #4/Random
29. Pre-set #3/Repeat
30. Pre-set #2/Intro
31. Pre-set #1/Pause
32. USB Port

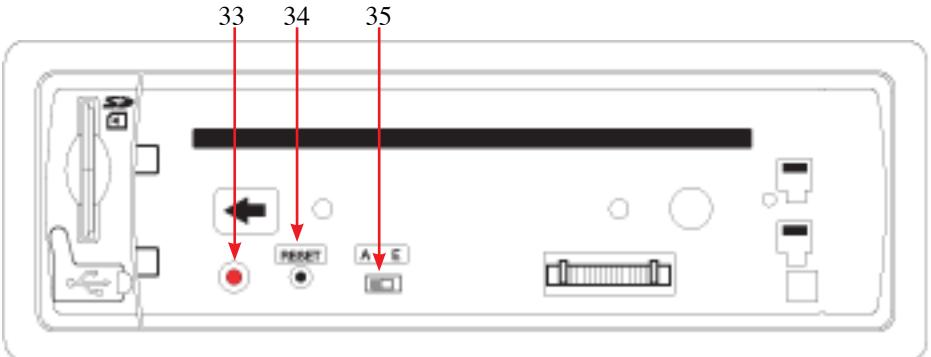

REMOTE CONTROL

This unit comes with a full remote control system. The CR-2025 Lithium battery is an included item with the remote control

Operating the remote control

Aim at the face panel of the CD Receiver, the maximum distance at which signals can be received is about 6 meters. Make sure that the signal path is not obstructed.

Do not drop or throw the remote control. Do not place the remote control in a location that is exposed to direct sunlight or next to a heating unit or other heat source.

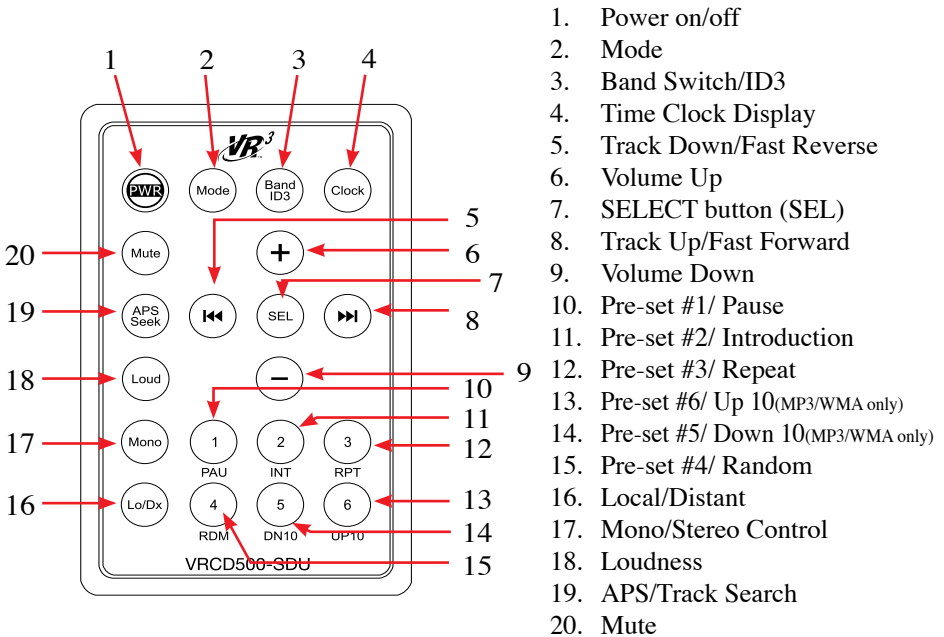

To replace the batteries:

- (1) Remove the cover from the back of the remote control.
- (2) Insert a CR-2025 Lithium battery.
- (3) Replace the cover on the back of the remote control.

Basic Operation

1. Tuning the Unit On / Off

Press any button to turn the unit on, the display will show a message WELCOME to indicate it is ready for use. Press and hold the POWER button again to turn the unit off.

2. Mode Selection

Press the “MOD” Button on the faceplate or the “MODE” button on the remote to select the play mode between SD Card, USB Port, AUX, RADIO and CD PLAY.

3. Loudness Control

Press the “LUD” Button on the faceplate or the “LOUD” button on the remote to emphasize the Bass output, the word “LOUD ON” shown on the display indicates that the loudness function is on. Press again to cancel. While listening to the unit play the letters “LUD” will be displayed on the right side of the display to indicate that the “LOUDNESS” function is on.

4. Mute Control

Press the “MUT” Button on the faceplate or the “MUTE” button on the remote to activate the Mute function, “MUTE ON” will be shown on the LCD. Press MUT again or rotate the volume knob to cancel.

5. Volume

Adjust the Volume by rotating the volume knob on the faceplate or press the “+ or -” button on the remote, the display will show VOL 0 - 47 (Numbers indicate the volume level).

6. Bass

Press the Volume knob on the faceplate or the “SEL” button on the remote until the display shows BAS 0. Rotate the volume knob on the faceplate or press the “+ or -” button on the remote to adjust the bass level.

7. Treble

Press the Volume knob on the faceplate or the “SEL” button on the remote until the display shows TRE 0. Rotate the volume knob on the faceplate or press the “+ or -” button on the remote to adjust the treble level.

8. Balance

Press the Volume knob on the faceplate or the “SEL” button on the remote until the display shows BAL R-L. Rotate the volume knob on the faceplate or press the “+ or -” button on the remote to adjust the volume balance of left & right speakers.

9. Fader

Press the Volume knob on the faceplate or the “SEL” button on the remote until the display shows FAD 0. Rotate the volume knob to adjust the volume balance between the front & rear speakers.

10. Subwoofer Control

Press and hold the Volume knob on the faceplate or the “SEL” button on the Remote until the LCD displays “DSP OFF”. Press the Volume knob again and the LCD displays “WOOFER OFF”. Rotate the Volume knob to activate the subwoofer control function, then leave the unit idle for your desired setting to take effect. While listening to the unit play the letters “SUB” will be displayed on the right side of the display to indicate that the subwoofer function is on. An external amplifier must be used with a subwoofer.

11. Clock

The clock can be set anytime when the power is ON. Press the “CLK” Button once, then press and hold “CLK” Button for 3 seconds, the time will blink on the display.

1. Rotate the volume knob to the right to

Basic Operation

adjust the hour.

2. Rotate the volume knob to the left to adjust the minute.

3. Press the “CLK” Button again or leave the unit idle for new setting to effect.

Press the “CLK” Button anytime to view the time clock display.

12. Preset Beep Sound

1. Press and hold the Volume knob on the faceplate or the “SEL” button on the remote, the LCD will show “DSP OFF”.

2. Press the Volume knob on the faceplate or the “SEL” button on the remote until the display shows “BEEP ON”, rotate the volume knob to toggle between “BEEP ON” and “BEEP OFF”, then leave the unit idle for your desired setting to take effect.

13. Preset Equalizer Function

On the faceplate press and hold the Volume knob or press the “SEL” button on the remote for 2 seconds, the display will show “DSP OFF”. Rotate the Volume knob or press the +/- button on the remote to choose one of the “EQ” pre-sets; POP, ROCK, CLASS, and FLAT. While listening to the unit play the letters “EQ” will be displayed on the right side of the display.

Radio Operation

1. Choose a Radio Frequency

Choose American or European Frequency by selecting the A/E switch. A is for American Frequencies (87.7, 87.9, etc) and E is for European frequencies (87.8, 88.0, etc). The switch is on the main unit, behind the front panel.

2. Choose Radio Band

Press the "BND/ID3" button on the faceplate or remote to select one of the 3 FM bands (FM1 - FM2 - FM3) or 2 AM bands (AM1 - AM2). Each band can store 6 preset stations, for a total of 30 preset memory stations.

3. SEEK 1 & SEEK 2

Press and hold the Volume knob on the faceplate, or the "SEL" button on the remote until "DSP OFF" is shown on the LCD, then press the Volume knob on the faceplate or the "SEL" button on the remote to cycle through the menu selections until "SEEK 1" is shown. Use the Volume knob on the faceplate, or the +/- Button on the remote to select either "SEEK 1" or "SEEK 2".

A. Seek 1

Press and hold the |<< or >>| button on the faceplate or remote for more than 1 second. The radio will seek the next strong and clear frequency. Repeat to seek more stations in your listening area with a strong signal.

B. Seek 2

Press and hold the |<< or >>| button on the faceplate or remote for station search. The search will not cease until you release the button.

4. Mono/Stereo Reception Control

In FM radio mode, press MONO button on the remote control to toggle between mono reception or stereo reception. The display will show "MONO" or "STEREO". Improvement of reception of distant stations can be done by selecting "MONO" operation which may cut down some reception noise. The "MONO/STEREO" function only works in radio mode.

5. Save Your Preset Stations

There are Six numbered preset buttons which can store and recall stations for each band. There are 5 bands and 30 available preset station slots. 3 FM bands, F1, F2, and F3 making a total of 18 preset stations in FM band. 2 AM bands, AM1 and AM2 making a total of total 12 preset stations in AM band.

6. Automatic Store/Preset Scan

A. Show Stations Preset

While listening to the FM Radio, press and hold the "F/PS" button on the faceplate or the APS button on the remote for 1 second. The receiver will automatically scan the saved stations of the 3 FM Bands. When listening to the AM radio, press "F/PS" button on the faceplate or the "APS" button on the remote for more than 3 seconds, the receiver will automatically scan and save stations for the 2 AM bands.

B. Reset Automatic Scan & Store

Press and hold the "F/PS" button on the faceplate or the "APS" button on the remote for 3 seconds and the receiver will scan the radio stations with the strongest signal in your area, then save them as pre-sets.

CD Operation

1. Insert/Eject CD

Insert a disc into CD slot with label side up. The disc will be automatically loaded into the unit, even when it is off or in radio mode. The word "LOAD" will blink on the display and the CD will play automatically. Press the "EJECT" Button to eject the disc from the slot. If the disc is not removed from the slot within 5 seconds, it will automatically be loaded into the slot again. When the disc is ejected and removed, the unit will automatically switch to radio mode.

2. Multi-Session CD Reading

This unit can read multi-session CDs. The multi-session reading will be activated automatically if the player detects a file that is written in multi-session format. Press and hold the Volume knob on the faceplate or the "SEL" button on the remote until "DSP OFF" is shown on the LCD. Then press the Volume knob on the faceplate or the "SEL" button on the remote to cycle through the menu selections until "MULT OFF" is shown. Use the VOL +/- Buttons on the faceplate or remote to choose "MULT ON" or "MULT OFF". The default is MULT OFF .

3. Selecting Tracks

On the Head Unit, press the >>| Button to advance to the next track on the CD. Track numbers will be shown on the display. Press and hold >>| to fast forward the track that is playing, the elapsed time on the faceplate will indicate where you are on the track. Press the << Button to go to a previous track. Track numbers will be shown on the display. Press and hold the << Button to fast reverse. Disc will play normally when the >>| or << Button is released. On the Remote Control, use the << or >>| Buttons.

4. Play/ Pause CD

On the Remote or Head Unit, press the No.1/PAU Button to pause the CD. Press this button again to resume playback.

5. Scanning Tracks

On the Remote or Head Unit, press the No.2/INT Button to play the first 10 seconds of each track. Press this button again to resume playback.

6. Repeat

On the Remote or Head Unit, press the No.3/RPT Button to repeat the same track continuously. "RPT ON" will appear on the display. Press this button again to stop repeating.

7. Random

On the Remote or Head Unit, press the No.4/RDM Button to play all the tracks in random order. "RDM ON" will appear on the display. Press this button again to stop random play.

Electronic Skip Protection - 12 or 45 seconds.

Press the Volume knob on the faceplate or the SEL button on the remote for 2 seconds. The display will show "DSP OFF". Press the Volume knob or the SEL button twice and "ESP12" will be displayed indicating that Electric Skip Protection will be activated for 12 seconds. With "ESP 12" on the display, use the VOL +/- Button to change the setting to "ESP 45", indicating that Electronic Skip Protection for 45 seconds is activated. Leave the unit idle for the new setting to take effect. The default is ESP 12. ESP 45 will be displayed in the center of the LCD.

MP3/WMA Operation

1. Insert/Eject CD

Insert a disc with MP3 and or WMA files into the CD slot with label side up. The disc will be automatically loaded into the unit, even when it is off or in radio mode. The word "MP3 DISC" will be displayed as the CD is loaded. The first file in the root folder will be played. As the file is playing "ROOT" will be displayed first, then any ID3 information available will be displayed as the file is playing. Press the "EJECT" Button to eject the disc from the slot. If the disc is not removed from the slot within 5 seconds, it will automatically be loaded into the slot again. When the disc is ejected and removed, the unit will automatically switch to radio mode.

2. Multi-Session CD Reading

This unit can read multi-session CDs. The multi-session reading will be activated automatically if the player detects a file that is written in multi-session format. Press and hold the Volume knob until "DSP OFF" is shown on the LCD, then press the Volume knob to cycle through the menu selections until "MULT OFF" is shown. Use the VOL +/- Button to choose "MULT ON" or "MULT OFF". The default is MULT OFF .

3. Selecting Tracks

On the Head Unit or Remote press the >>| Button to advance CD to the next track. Track numbers will be shown on the display. Press and hold >>| to fast forward.

On the Head Unit or Remote press the |<< Button to go to a previous track. Track numbers will be shown on the display. Press and hold the |<< Button to fast reverse. Disc will play normally when the >>| or |<< Button is released.

4. Play/ Pause CD

On the Remote or Head Unit, press the No.1/PAU button to pause the CD. Press this button again to resume playback.

5. Scanning Tracks

On the Remote or Head Unit, press the No.2/INT button to play the first 10 seconds of each track. Press this button again to resume playback.

6. Repeat

On the Remote or Head Unit, press the No.3/RPT button to repeat the same track continuously. "RPT ON" will appear on the display. Press this button again to stop repeating.

7. Random

On the Remote or Head Unit, press the No.4/RDM button to play all the tracks in random order. "RDM ON" will appear on the display. Press this button again to stop random play.

8. UP 10

Press the No.6/UP10 button to advance 10 tracks at a time.

9. DN 10

Press the No.5/DN10 button to go back 10 tracks at a time.

MP3/WMA Operation

Search Modes

There are 4 search modes to help find your favorite MP3 & WMA tracks. THESE SEARCH MODES ONLY WORK WITH MP3/WMA FILES ON CDS, USB FLASH MEMORY, AND SD CARDS. These search modes do not work with any other CD types.

A. Simple Track Search

On the faceplate or remote press the << or >>| button to go to the next track or previous track. Press the Number 5 button to go back 10 tracks at once or press the Number 6 button to advance 10 tracks at once.

B. Track Search

On the faceplate press the F/PS button or on the remote press the APS button and the display will show "TRK SCH".

Press the Volume knob on the faceplate or the SEL button on the remote again so that "TRK 001" displays and the digit "1" will blink on the display.

Rotate the Volume knob on the faceplate or on the remote press the +/- button to choose your desired track, then press the Volume knob on the faceplate or the SEL button on the remote again to confirm the selection. The selected track will be searched for and then played.

C. File Search

On the faceplate press the F/PS button or on the remote press the APS button and the display will show "FILE SCH". Press the Volume knob on the faceplate or the SEL button on the remote to enter the root folder of the disc. Use the VOL +/- Button to choose a folder in the root folder, then press the Volume knob to confirm. The selected

folder will be opened.

D. Character Search

Character Search is for searching for files by their file names. On the faceplate press the F/PS button, or on the remote press the ABS button three times, "CHAR SCH" will be displayed. Press the Volume knob on the faceplate, or the SEL button on the remote and the first character will blink on the display. Use the VOL +/- Button to change the character. Press the SEL button once to confirm the character entered and advance to the next character. After you have input the name, press and hold the Volume knob to confirm. The song nearest alphabetically to the name input will be found and then begin to play.

E. Random

While playing MP3 and or WMA files on a CD, press the No.4/RDM Button, "RDM" will appear in the LCD and the unit will play the tracks on the CD at random.

8. ID3 Tag

If an Mp3/WMA file has ID3 tag information, it will be displayed on the LCD. If there is no ID3 tag information, nothing will shown on LCD. On the left side of the LCD there is an icon(fig.1) with the words Folder, Music, & Artist. When Folder is lit the folder name is displayed on the LCD. When Music is lit the file name is displayed on the LCD. When Artist is lit the artist's name is displayed on the LCD.

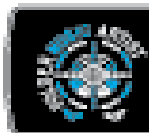

Fig. 1

USB Flash Memory Operation

To play MP3 / WMA files from a USB Flash Memory Drive, remove the cover from the USB port, insert the USB Flash Memory Drive into the USB port. The unit will start playing MP3/WMA files on the USB Flash Memory Drive automatically. Or press the MODE Button to select USB when the unit has a USB Flash Memory Drive already inserted into the USB port

1. Play / Pause

When playing MP3/WMA in the USB drive, press the No.1/PAU Button to pause playback. Press the No.1/PAU Button again to resume.

2. Selecting Files

If the MP3/WMA files are stored in folders on the USB drive, the unit will start by playing the first song in the first folder.

After playing all the files sequentially in the first folder, the unit will play sequentially all of the files in the next folder. The unit will continue playing through all of the folders on the USB drive in this manner.

If the USB drive has loose files and folders containing files, it will play the loose files sequentially, then it will play the files in the folders sequentially.

3. Repeat

Press the No.3/RPT Button to repeat the same files continuously. "RPT ON." will appear on the display. Press this button again to resume normal operation.

4. Random

Press the No.4/RDM Button to play all the files in USB drive in random order. "RDM ON" will appear on the display. Press this button again to stop random play.

5. UP 10

Press the No.6/UP10 Button to advance 10 files at a time.

6. DN 10

Press the No.5/DN10 Button to go back 10 files at a time.

7. ID3 Tag

If an MP3/WMA file has ID3 tag information, it will be displayed on the LCD. If there is no ID3 tag information, nothing will shown on LCD. On the left side of the LCD there is an icon(fig.1) with the words Folder, Music, & Artist. When Folder is lit the folder name is displayed on the LCD. When Music is lit the file name is displayed on the LCD. When Artist is lit the artist's name is displayed on the LCD.



Fig. 1

SD Memory Card Operation

To play MP3 / WMA files from a SD Memory Card, fully insert the SD Memory Card into the SD Memory Card slot, on the left side of the unit, until you hear and feel a click. MEM-CARD will be shown on the LCD and the unit will start playing the MP3/WMA files on the SD Memory Card. If the unit already has a SD Memory Card inserted into the SD Memory Card slot, press the MODE Button to select MEM-CARD.

Press the SD card again to eject the card from the slot. When the SD Memory Card is ejected, the unit will automatically be switched to the radio mode.

1. Play / Pause

When playing MP3/WMA in the SD card slot, press the No.1/PAU Button to pause playback. Press the No.1/PAU Button again to resume.

2. Selecting Tracks

If the MP3/WMA files are stored in folders on the SD Memory Card, the unit will start by playing the first song in the first folder. After playing all the files sequentially in the first folder, the unit will play sequentially all of the files in the next folder. The unit will continue playing through all of the folders on the SD Memory Card in this manner.

If the SD Memory Card has loose files and folders containing files, it will play the loose files sequentially, then it will play the files in the folders sequentially. The No.5/DN10 and No.6/UP10 Buttons are used to advance ten tracks at a time or go back ten tracks at a time.

3. Repeat

Press the No.3/RPT Button to repeat the same files continuously. "RPT ON." will appear on the display. Press this button again to stop repeating.

4. Random

Press the No.4/RDM Button to play all the files in USB drive in random order. "RDM ON" will appear on the display. Press this button again to stop random play.

5. UP 10

Press the No.6/UP10 Button to advance 10 files at a time.

6. DN 10

Press the No.5/DN10 Button to go back 10 files at a time.

7. ID3 Tag

If an MP3/WMA file has ID3 tag information, it will be displayed on the LCD. If there is no ID3 tag information, nothing will shown on LCD. On the left side of the LCD there is an icon(fig.1) with the words Folder, Music, & Artist. When Folder is lit the folder name is displayed on the LCD. When Music is lit the file name is displayed on the LCD. When Artist is lit the artist's name is displayed on the LCD.

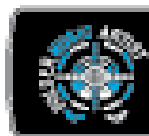

Fig. 1

AUX IN, RCA OUT, & SUBWOOFER

1. Auxiliary Input

The Auxiliary Input Jack is on the front of the unit on the right side. Insert the supplied AUX IN cable's into the AUX IN jack. Press the Mode button to choose AUX. Connect any portable audio device such as a DVD player or VCD player to the AUX IN cable. Use the volume control to adjust the volume.

2. RCA Line Out

The RCA Output Jack is on the back of the unit on the right side. (See figure 1) This output is for connecting an amplifier, equalizer, or other audio component that requires a pre-amp out connection. (Red = Right, White = Left) Follow the manufacturers instructions for the audio component that you are connecting

4. Subwoofer Output

The Subwoofer Output Jack is on the back of the unit on the right side. (See figure 1) This output is for connecting a subwoofer amplifier. You must connect an amplifier to the Subwoofer Output Jack to drive a subwoofer. Follow the amplifier's installation instructions. Press and hold the Volume knob on the faceplate or the SEL button on the Remote, "DISP OFF" will be shown on the LCD. To activate subwoofer control, press the Volume knob or the "SEL" button on the Remote until you see "SUB OFF", then use the Volume knob or the +/- button on the Remote to choose "SUB ON" or "SUB OFF".

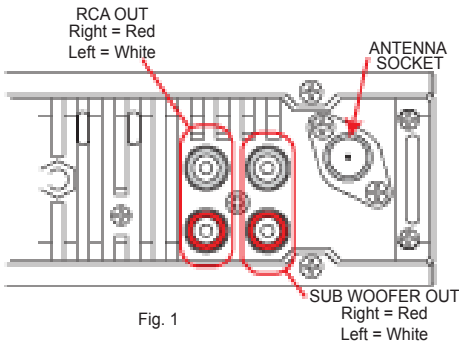

Simple Troubleshooting Guide

PROBLEM	CAUSE/SOLUTION
No Power	Check wiring connections. Check and make sure the fuse is not blown. Replace with the proper rating/size fuse.
Some errors occur in the LCD or nothing functions when buttons are pressed.	Press the RESET Button.
Unable to receive stations	Check and make sure the antenna is connected properly.
Poor radio reception	Check and make sure the antenna is the correct length. Make sure the antenna is not broken. If the antenna is broken, replace it. The antenna is poorly grounded. Check and make sure the antenna is grounded at mounting location.
CD can't be loaded	The Transport Screws have not been removed. A CD is already loaded in the player. Eject CD.
Songs keep skipping	The CD is dirty or damaged.
MP3/WMA Files on the USB/SD flash memory do not play.	Flash memory is formatted as NTSC. Format the flash memory as FAT or FAT32. The files have Digital Rights Management(DRM). If the files you are attempting to play were purchased online, they may have Digital Rights Management, this unit is not DRM compatible
I hear multiple files playing at the same time.	You may have both types of memory connected to the unit at the same time.



For Answers to Your Questions

Visit us on the Web at:

www.vr-3.com

Give Us a Call, We'll Help You Install!

1-800-445-1797

Specifications

GENERAL

Operating Power	12 Volts DC, Negative Ground
Output Wiring	Designed for using four speakers only
RCA line out	low-level outputs - 1000MV
Output Impedance	Compatible 4 to 8 Ohm Speakers
Fuses	1 amp and 10 amp
Dimensions	178mm(W) x 178mm(D) x 51mm (H)
Weight	2.6 Kg

CD PLAYER

Signal / Noise Ratio	>80dB
Frequency Response	20 Hz~20KHz
Channel Separation	>62dB
D / A Converter	16 Bit

FM TUNER

Tuning Range	(USA) 87.5-107.9MHz, (EUROPE) 87.5-108 MHz
FM Mono Sensitivity	12dB
Stereo Separation @ 1 Khz.....	40dB

AM TUNER

Tuning Range	(USA) 530-1710KHz, (EUROPE) 522-1620 KHz
Am Sensitivity	20qV

NOTE:

Due to continuous product improvements, specifications and designs are subject to change without notice.

Limited Warranty

VIRTUAL REALITY SOUND LABS® products are designed and manufactured to provide a high level of trouble-free performance. VIRTUAL REALITY SOUND LABS® warrants, to the original purchaser, that its products are free from defects in material and workmanship for 30 days from the date of original purchase, as part of our commitment to product excellence. VIRTUAL REALITY SOUND LABS® and/or its affiliates routinely improves the designs, materials or production methods of its existing products. Because it is impractical to publicize all changes in every product, we reserve the right to make such changes without notice.

CONDITIONS OF WARRANTY:

If during the 30 day warranty period your new product is found to be defective, VIRTUAL REALITY SOUND LABS® will repair such defect, or replace the product, without charge for parts or labor subject to the following conditions:

1. All repairs must be performed by VIRTUAL REALITY SOUND LABS® and/or its affiliates in Eatontown, New Jersey.
2. The equipment must not have been altered or been damaged through negligence, accident, or improper operation.
3. The replacement of parts are exempted from this warranty when replacement is necessary due to normal wear and tear.
4. All warranty claims must be accompanied by a copy of the sales receipt or bill of sale.
5. Repair or replacement parts supplied by VIRTUAL REALITY SOUND LABS® under this warranty are protected only for the unexpired portion of the original warranty.
6. In the case of car stereos, this warranty does not extend to the elimination of car static or motor noise; correction of antenna problems; costs incurred for the removal or reinstallation of the product; damage to tapes, speakers, accessories or car electrical systems.
7. VIRTUAL REALITY SOUND LABS® will not be responsible for any charge incurred for installation.

OWNER'S RESPONSIBILITIES:

VIRTUAL REALITY SOUND LABS® will make every effort to provide warranty service within a reasonable period of time.

SHOULD YOU HAVE ANY QUESTIONS ABOUT SERVICE RECEIVED, OR IF YOU WOULD LIKE ASSISTANCE IN OBTAINING SERVICE, PLEASE CALL TOLL FREE 1-800-445-1797, 8:30am - 4:30pm EST.

In order to provide you with the proper warranty service, we request that you adhere to the following procedure:

1. Include a copy of your sales receipt or bill of sale with your unit when it is returned for warranty service.
2. If it is necessary to return your product for service, please return it securely packed, preferably in the original shipping carton, and freight and insurance prepaid to the following address: VIRTUAL REALITY SOUND LABS, Service Department, 41 James Way, Eatontown, New Jersey 07724.
3. Please include a detailed explanation of the problem you are having.
4. If your product is found by VIRTUAL REALITY SOUND LABS® to have a defect in material or workmanship, within the warranty period, it will be repaired or replaced at no charge and returned to you prepaid. Where permitted by law VIRTUAL REALITY SOUND LABS® liability shall be limited to that set forth in this warranty. This warranty shall be the exclusive remedy of the purchaser.

VIRTUAL REALITY SOUND LABS® makes no other warranty of any kind, expressed or implied; and all implied warranties, are hereby disclaimed by VIRTUAL REALITY SOUND LABS® and excluded from this warranty, VIRTUAL REALITY SOUND LABS® and/or its affiliates, the manufacturer, distributor and seller shall not be liable for any injury, loss or damage, incidental or consequential, arising out of the use or intended use of the product.

