

VIKING

TECHNICAL Practice

TELECOM SOLUTIONS FOR THE 21ST CENTURY

K-1900-30

**Touch Tone Dialer
with Redialing**

February 22, 2010

Smart Touch Tone Dialer with Redialing



The **K-1900-30** is an automatic dialer that dials a 1-20 digit phone number, and can be programmed to call up to 4 additional phone numbers if the line is busy, or is not answered. The **K-1900-30** can be used to add the smart dialing features of a Viking Model **E-30**, to other non-dialing entry phones such as the **E-10A**, **E-20B**, **E-40** series, **E-50** series, **E-60** series, **E-70** series, **K-1500** series phones, etc.

The **K-1900-30** connects directly to an analog CO line, Analog PBX station, or analog port of a VOIP adapter, and works with any analog phone. Touch Tone programming can be done locally, or remotely by calling into the unit. A Touch Tone identification number can be programmed to help identify the location of the call.

The **K-1900-30** will continue to call through the programmed phone numbers one by one until the call is answered, or it can be programmed to limit the number of times it cycles through the phone numbers. User touch tone dialing can be restricted, or allowed for Touch Tone door strike applications.

Features

- Non-volatile E² memory (no batteries required)
- Compatible with analog phones
- Compatible with Viking E-series and K-series phones
- Dials up to five 1-20 digit phone numbers
- Cycles thru phone numbers until answered
- Programmable max call timer
- Local and remote Touch Tone programming
- Ring-thru allows calling into the phone
- Call status LED indicator
- 12V DC adapter included

Applications

- Add **E-30** intelligent auto dialing features to any phone
- Parking lot/ramp dialer
- ATM machine dialer
- Door entry dialer

Phone... 715.386.8861

Specifications

Power: 120VAC / 12VDC 500mA, UL listed adapter provided
Dimensions: 76mm x 112mm x 36mm (3" x 4.4" x 1.4")
Shipping Weight: 0.68kg (1.5lbs)
Environmental: 0°C to 32°C (32°F to 90°F) with 5% to 95% non-condensing humidity
Talk Battery Output: 30V DC nominal
DTMF Dialing Speed: 120mS on/off
Connections: (4) cage clamp screw terminals

info@vikingelectronics.com

<http://www.vikingelectronics.com>

IF YOU HAVE A PROBLEM WITH A VIKING PRODUCT, PLEASE CONTACT: VIKING TECHNICAL SUPPORT AT (715) 386-8666

Our Technical Support Department is available for assistance Monday 8am - 4pm and Tuesday through Friday 8am - 5pm central time. So that we can give you better service, before you call please:

1. Know the model number, the serial number and what software version you have (see serial label).
2. Have your Technical Practice in front of you.
3. It is best if you are on site.

RETURNING PRODUCT FOR REPAIR

The following procedure is for equipment that needs repair:

1. Customer must contact Viking's Technical Support Department at 715-386-8666 to obtain a Return Authorization (RA) number. The customer **MUST** have a complete description of the problem, with all pertinent information regarding the defect, such as options set, conditions, symptoms, methods to duplicate problem, frequency of failure, etc.
2. Return equipment in original box or in proper packing so that damage will not occur while in transit. Static sensitive equipment such as a circuit board should be in an anti-static bag, sandwiched between foam and individually boxed. All equipment should be wrapped to avoid packing material lodging in or sticking to the equipment. Include ALL parts of the equipment. C.O.D. or freight collect shipments cannot be accepted. Ship cartons prepaid to: **Viking Electronics, 1531 Industrial Street, Hudson, WI 54016**
3. Return shipping address: Be sure to include your return shipping address inside the box. We cannot ship to a PO Box.
4. RA number on carton: In large printing, write the R.A. number on the outside of each carton being returned.

RETURNING PRODUCT FOR EXCHANGE

The following procedure is for equipment that has failed out-of-box (within 10 days of purchase):

1. Customer must contact Viking's Technical Support at 715-386-8666 to determine possible causes for the problem. The customer **MUST** be able to step through recommended tests for diagnosis.
2. If the Technical Support Product Specialist determines that the equipment is defective based on the customer's input and troubleshooting, a Return Authorization (R.A.) number will be issued. This number is valid for fourteen (14) calendar days from the date of issue.
3. After obtaining the R.A. number, return the approved equipment to your distributor, referencing the R.A. number. Your distributor will then replace the product over the counter at no charge. The distributor will then return the product to Viking using the same R.A. number.
4. **The distributor will NOT exchange this product without first obtaining the R.A. number from you. If you haven't followed the steps listed in 1, 2 and 3, be aware that you will have to pay a restocking charge.**

LIMITED WARRANTY

Viking warrants its products to be free from defects in the workmanship or materials, under normal use and service, for a period of one year from the date of purchase from any authorized Viking distributor or 18 months from the date manufactured, whichever ever is greater. If at any time during the warranty period, the product is deemed defective or malfunctions, return the product to Viking Electronics, Inc., 1531 Industrial Street, Hudson, WI, 54016. Customer must contact Viking's Technical Support Department at 715-386-8666 to obtain a Return Authorization (R.A.) number.

This warranty does not cover any damage to the product due to lightning, over voltage, under voltage, accident, misuse, abuse, negligence or any damage caused by use of the product by the purchaser or others.

NO OTHER WARRANTIES. VIKING MAKES NO WARRANTIES RELATING TO ITS PRODUCTS OTHER THAN AS DESCRIBED ABOVE AND DISCLAIMS ANY EXPRESS OR IMPLIED WARRANTIES OR MERCHANTABILITY OR FITNESS FOR ANY PARTICULAR PURPOSE.

EXCLUSION OF CONSEQUENTIAL DAMAGES. VIKING SHALL NOT, UNDER ANY CIRCUMSTANCES, BE LIABLE TO PURCHASER, OR ANY OTHER PARTY, FOR CONSEQUENTIAL, INCIDENTAL, SPECIAL OR EXEMPLARY DAMAGES ARISING OUT OF OR RELATED TO THE SALE OR USE OF THE PRODUCT SOLD HEREUNDER.

EXCLUSIVE REMEDY AND LIMITATION OF LIABILITY. WHETHER IN AN ACTION BASED ON CONTRACT, TORT (INCLUDING NEGLIGENCE OR STRICT LIABILITY) OR ANY OTHER LEGAL THEORY, ANY LIABILITY OF VIKING SHALL BE LIMITED TO REPAIR OR REPLACEMENT OF THE PRODUCT, OR AT VIKING'S OPTION, REFUND OF THE PURCHASE PRICE AS THE EXCLUSIVE REMEDY AND ANY LIABILITY OF VIKING SHALL BE SO LIMITED.

IT IS EXPRESSLY UNDERSTOOD AND AGREED THAT EACH AND EVERY PROVISION OF THIS AGREEMENT WHICH PROVIDES FOR DISCLAIMER OF WARRANTIES, EXCLUSION OF CONSEQUENTIAL DAMAGES, AND EXCLUSIVE REMEDY AND LIMITATION OF LIABILITY, ARE SEVERABLE FROM ANY OTHER PROVISION AND EACH PROVISION IS A SEPARABLE AND INDEPENDENT ELEMENT OF RISK ALLOCATION AND IS INTENDED TO BE ENFORCED AS SUCH.

FCC REQUIREMENTS

This equipment complies with Part 68 of the FCC rules and the requirements adopted by the ACTA. On the side of this equipment is a label that contains, among other information, a product identifier in the format US:AAAEQ##TXXXX. If requested, this number must be provided to the telephone company.

The REN is used to determine the number of devices that may be connected to a telephone line. Excessive REN's on a telephone line may result in the devices not ringing in response to an incoming call. In most but not all areas, the sum of the REN's should not exceed five (5.0). To be certain of the number of devices that may be connected to a line, as determined by the total REN's, contact the local telephone company. For products approved after July 23, 2001, the REN for this product is part of the product identifier that has the format US:AAAEQ##TXXXX. The digits represented by ## are the REN without a decimal point (e.g., .03 is a REN of 0.3). For earlier products, the REN is separately shown on the label.

The plug used to connect this equipment to the premises wiring and telephone network must comply with the applicable FCC Part 68 rules and requirements adopted by the ACTA. If your home has specially wired alarm equipment connected to the telephone line, ensure the installation of this K-1900-30 does not disable your alarm equipment. If you have questions about what will disable alarm equipment, consult your telephone company or a qualified installer.

If the K-1900-30 causes harm to the telephone network, the telephone company will notify you in advance that temporary discontinuance of service may be required. But if advance notice isn't practical, the telephone company will notify the customer as soon as possible. Also, you will be advised of your right to file a complaint with the FCC if you believe it is necessary.

The telephone company may make changes in its facilities, equipment, operations, or procedures that could affect the operation of the equipment. If this happens, the telephone company will provide advance notice in order for you to make

the necessary modifications to maintain uninterrupted service.

If trouble is experienced with the K-1900-30, for repair or warranty information, please contact:

Viking Electronics, Inc., 1531 Industrial Street, Hudson, WI 54016 (715) 386-8666

If the equipment is causing harm to the telephone network, the telephone company may request that you disconnect the equipment until the problem is resolved.

Connection to Party Line Service is subject to State Tariffs. Contact the state public utility commission, public service commission or corporation commission for information.

WHEN PROGRAMMING EMERGENCY NUMBERS AND (OR) MAKING TEST CALLS TO EMERGENCY NUMBERS:

Remain on the line and briefly explain to the dispatcher the reason for the call. Perform such activities in the off-peak hours, such as early morning or late evenings.

It is recommended that the customer install an AC surge arrester in the AC outlet to which this device is connected. This is to avoid damaging the equipment caused by local lightning strikes and other electrical surges.

PART 15 LIMITATIONS

This equipment has been tested and found to comply with the limits for a Class A digital device, pursuant to Part 15 of the FCC Rules. These limits are designed to provide reasonable protection against harmful interference when the equipment is operated in a commercial environment. This equipment generates, uses, and can radiate radio frequency energy and, if not installed and used in accordance with the instruction manual, may cause harmful interference to radio communications. Operation of this equipment in a residential area is likely to cause harmful interference in which case the user will be required to correct the interference at his own expense.

Installation

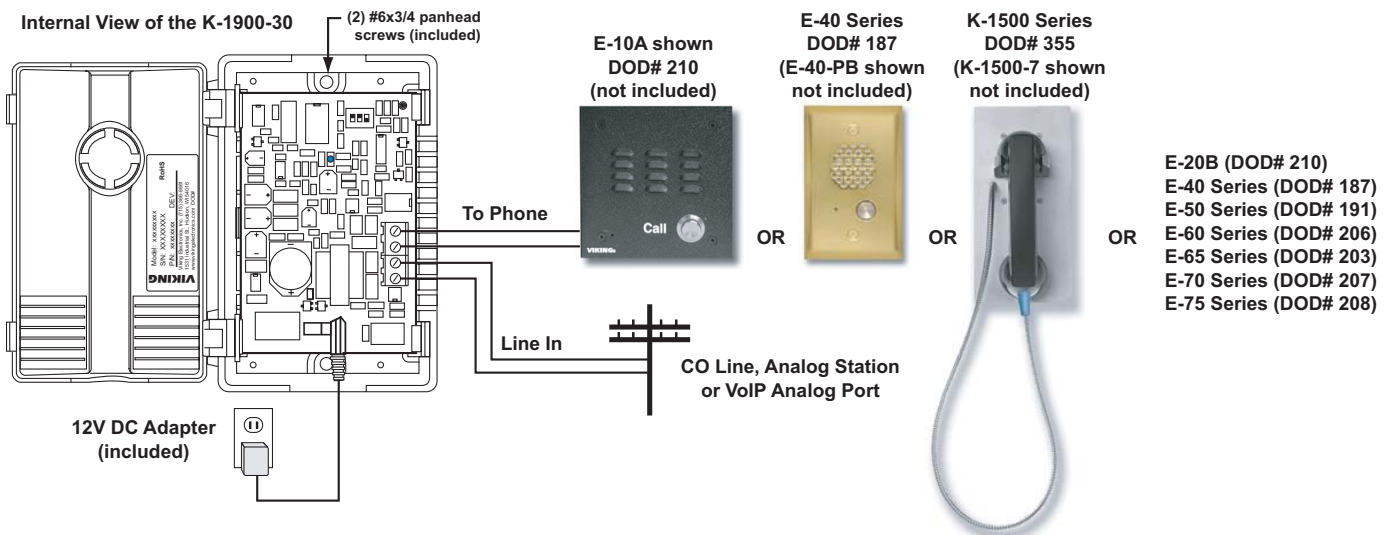

IMPORTANT: Electronic devices are susceptible to lightning and power station electrical surges from both the AC outlet and the telephone line. It is recommended that a surge protector be installed to protect against such surges. Contact Panamax at (800) 472-5555 or Electronic Specialists Inc. at (800) 225-4876.

Alternate Application

There may be applications in which the **K-1900-30** Smart Dialer is used with a phone that already has dialing capabilities. For example, the **K-1900-30** may be used with a **K-1900-8** hot line phone when the application calls for a user touch tone keypad. **Note:** If the **K-1900-30** Smart Dialer is used along with an auto dialing phone such as this, clear out the speed dial number in the **K-1900-8** so it does not dial on top of the Smart Dialer. Also be sure to program the vandal resistant hot line phone to allow other touch tone dialing by accessing the programming mode in the **K-1900-8** and entering ***4**. Please see the **K-1900-8** (DOD# 362) Technical Practice for complete programming instructions.

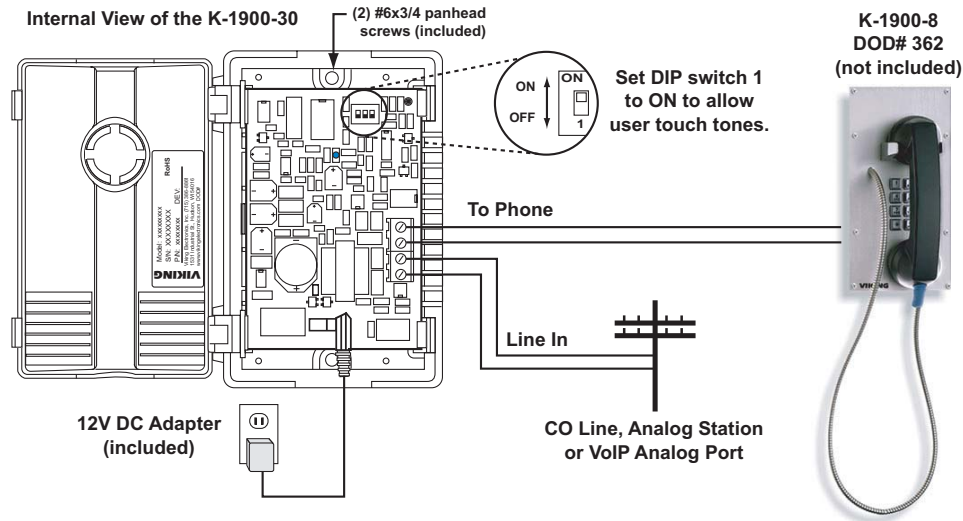

Programming

A. Accessing the Programming Mode

1. Local Programming

Step 1.	Move DIP switch 3 to the ON position (see section J).
Step 2.	Take the phone connected to the PHONE port off-hook. A double beep should be heard indicating that the programming mode has been entered.
Step 3.	Program as shown in sections B - I .
Step 4.	To exit programming, simply hang-up the phone.
Step 5.	When finished, DIP switch 3 must be placed back in the OFF position for normal operation (see section J).

2. Remote Programming Without the Security Code

Step 1.	Move DIP switch 3 switch to the ON position (see section J).
Step 2.	Connect a C.O. line or analog PABX/KSU station to the LINE IN port.
Step 3.	From a touch tone phone, call the line connected to the K-1900-30 .
Step 4.	When the K-1900-30 answers, a double beep will indicate that programming has been entered.
Step 5.	Program as shown in sections B - I .
Step 6.	To exit programming, enter ##7 or do not enter any touch tones for approximately 20 seconds. Three beeps will be heard, followed by an automatic disconnect.
Step 7.	When finished, DIP switch 3 must be placed back in the OFF position for normal operation (see section J).

3. Remote Programming With the Security Code

Step 1.	Connect a C.O. line or analog PABX/KSU station to the LINE IN port.
Step 2.	From a touch tone phone, call the line connected to the K-1900-30 .
Step 3.	When answered, enter * followed by the six digit security code, factory set to 845464 (see section B next page). A double beep will indicate that programming has been entered.
Step 4.	Program as shown in sections B - I .
Step 5.	To exit programming, enter ##7 or do not enter any touch tones for approximately 20 seconds. Three beeps will be heard, and the line will be reconnected back to the phone.

B. Security Code

A six digit number may be used to access the programming mode. The security code has been factory set to **845464** (V-I-K-I-NG). It is recommended that you change the security code to a personal 6 digit number as follows:

Step 1.	Access programming as shown in section A .
Step 2.	Enter your new security code followed by #47 .
Step 3.	To exit remote programming, enter ##7 or do not enter any touch tones for at least 20 seconds. To exit local programming, simply hang up the phone.

Note: The security code must be six digits in length and **MUST NOT** contain a * or #. If you have forgotten your security code, see section “**A. Local Programming**” or “**Remote Programming Without the Security Code.**”

C. Programming Features Quick Reference

	Enter Digits	- then -	Memory Location
First speed dial number (factory cleared)	0-20 digits	+	#00
Second speed dial number (factory cleared)	0-20 digits		#01
Third speed dial number (factory cleared)	0-20 digits	+	#02
Fourth speed dial number (factory cleared)	0-20 digits		#03
Fifth speed dial number (factory cleared)	0-20 digits	+	#04
To clear any speed dial number	(no digits)		#00 - #04
To add a * at any point in the dialing string	**	+	
To add a # at any point in the dialing string	*#		
Add a 4 second pause at any point in the dialing string	*7		
Add a 1 second pause at any point in the dialing string	*8		
Identification number (factory cleared)	0-20 digits	+	#20
Maximum call time, 00-99 min (factory set to 3 min, 00 = 30 sec, no digits = disabled)	2 digits	+	#42
Maximum ring-no-answer time, 00-99 sec (factory set to 30 sec, 00 = disabled)	2 digits	+	#43
Lap counter, 00-99 laps (factory set to 01, 00 = disabled)	2 digits	+	#44
Inbound rings before answering, 0-9 rings (factory set to 2, 0 = no answer)	1 digit	+	#45
Change the Security code (factory set to 845464)	6 digits	+	#47
To Exit Programming	##7		
To clear all programming (load factory settings)	###		

D. Speed Dial Numbers

Note: Up to 20 digits can be stored in each dial position. Special features such as pause, touch tone * and # count as single digits.

The speed dial number programmed in location **#00** is the number that is dialed when the phone first comes off hook. Additional speed dial numbers will be dialed when there is no answer or a busy signal is detected. To program, enter the desired speed dial number followed by the location number (**#00 - #04**). To clear a speed dial location, simply enter the memory location (**#00 - #04**) alone. The **K-1900-30** is factory set with no speed dial numbers programmed.

To Program the K-1900-30 to...	Step 1 (see section A)	Step 2 - Enter Digits
...to store 555-1234 as the first emergency speed dial number	Enter programming	5551234#00
...to store a touch tone 9, a four second pause and then dial 333-4444 into the second speed dial memory position	Enter programming	9*73334444#01
...to clear the first speed dial number	Enter programming	#00

E. Identification Number (memory location #20)

A touch tone I.D. number (up to 20 digits) can be used to identify the call, and is given out when the receiving party presses a touch tone *. To program the optional I.D. number, enter the desired number followed by **#20**. **Example:** To store 333 as the I.D. number, enter: **333#20**.

F. Maximum Call Time (memory location #42)

The Maximum Call Time can be used to cut off a call. Once the call is answered, if it lasts longer than the time programmed in minutes, the phone line will be dropped and a busy signal will be sent to the phone. This two digit number can range from 01 to 99 minutes or enter 00 for 30 seconds. To disable this feature enter **#42** without any preceding digits. This time is factory set to **03** (3 minutes). If the **K-1900-30** is being used with a Viking **E-Series** or **K-Series** phones, be sure to disable that phone's maximum call timer.

G. Maximum Ring-No-Answer Time (memory location #43)

After the **K-1900-30** dials a speed dial number, it listens to the phone line for busy, ringing, or someone answering the call. If the **K-1900-30** does not determine that the call has been answered within the Maximum Ring-No-Answer Time, the call will be disconnected, and the **K-1900-30** will call the next speed dial number. This two digit number can range from 01 to 99 seconds and can be disabled by entering **#43** without any preceding digits. As a general rule, allow 6 seconds for each ring you desire at the distant phone. The factory setting is 30 seconds, or about 5 rings.

H. Lap Counter (memory location #44)

The lap counter is a programmable counter that determines how many times the **K-1900-30** will cycle through its list of up to 5 speed dial numbers before it stops the dialing process and hangs up. When all of the programmed phone numbers have been dialed, the lap counter is incremented and the dialing process repeats. When the lap counter has been met, the dialing process stops. This feature is factory set to **01**. To disable the Lap Counter, enter **00** in memory location **#44**. **Caution:** Since the **K-1900-30** dialer is programmed to dial the next number on ring-no-answer and/or busy signal, the **K-1900-30** will continuously cycle through the programmed speed dial numbers forever until the call is answered, if the lap counter is disabled.

I. Inbound Rings Before Answering (memory location #45)

The **K-1900-30** is factory programmed to answer an inbound call after 2 rings. This way a Viking **E-Series** phone that is set to auto answer, will do so on the first ring, and monitoring or remote programming can be achieved. Yet, if the **E-Series** phone is not set to answer, the **K-1900-30** will answer after the second ring which will allow remote programming. When programming, enter a single digit then **#45**. Enter **0** then **#45** to disable. Factory set to 2 rings.

J. DIP Switch Programming

Switch	Position	Description
1	OFF	No user dialing allowed. Restrict the call if touch tone or pulse dialing is detected after the call is connected (factory setting).
1	ON	Allow user dialing. For use with door strike control, such as the Viking model SRC-1 .
2	OFF	When busy signal is detected, the K-1900-30 will call the next speed dial number (factory setting).
2	ON	Ignore busy signal.
3	OFF	Normal operation mode (factory setting).
3	ON	Learn mode: The K-1900-30 automatically drops into programming mode. Two beeps are given and no security code is required. Use this option if you have forgotten your security code.

Internal View of the K-1900-30

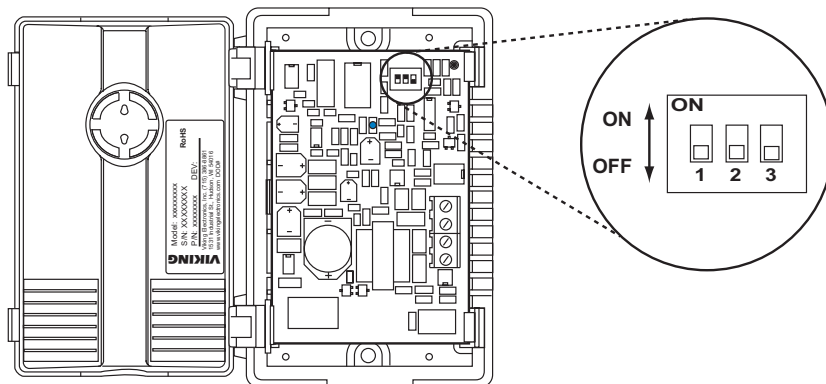

Operation

When the phone comes off hook (or the "CALL" button is pressed on a Viking phone), the **K-1900-30** dials a pre-programmed telephone number. In the event the line is busy or there is a ring-no-answer, the unit can be programmed to call additional phone numbers. The **K-1900-30** dialer then cycles through up to 5 preprogrammed speed dial numbers until the call is answered, or the Lap Counter limit is met. Once answered, the * key will send the DTMF I.D. number (if programmed). If the call reaches the programmable maximum call time, the **K-1900-30** will disconnect the call.

Product Support Line...715.386.8666

Fax Back Line...715.386.4345

Due to the dynamic nature of the product design, the information contained in this document is subject to change without notice. Viking Electronics, and its affiliates and/or subsidiaries assume no responsibility for errors and omissions contained in this information. Revisions of this document or new editions of it may be issued to incorporate such changes.