



User Guide

BT STUDIO 500
BT STUDIO 500 TWIN



Welcome...

to your BT Studio 500
Digital Cordless Telephone
Answering Machine

- 12 minutes digital recording time with a capacity for up to 59 messages.
- Access your messages from any other modern telephone.
- Use Caller Display and the calls list to see who is calling before you pick up the phone and keep track of incoming calls.
- Use the Quickdial directory to store and dial up to 10 of most frequently used phone numbers.
- As a Digitally Enhanced Cordless Telecommunications (DECT) product, BT Studio 500 provides digital quality call clarity.



This User Guide provides you with all the information you need to get the most from your phone.

Additional instructions are included for the BT Studio 500 Twin.

Before you make your first call you will need to set up your phone. Follow the simple instructions in ‘Getting Started’, on the next few pages.

■ **Need help?**

If you have any problems setting up or using your BT Studio 500 please contact the Helpline on **0870 605 8047**.

Alternatively, you may find the answer in ‘Help’ at the back of this guide.

Got everything?

- BT Studio 500 handset
- BT Studio 500 base
- 2 x AAA NiMH rechargeable batteries
- Mains power adaptor
- Telephone line cord

If you have purchased the BT Studio 500 Twin you will also have:

- BT Studio 500 additional handset
- BT Studio 500 charger
- 2 x AAA NiMH rechargeable batteries
- Mains power adaptor

In this guide

Getting started

Location	.6
Setting up the base	.6
Setting up the charger	.8

Getting to know your phone

Handset buttons	.10
Handset display icons	.11
Base buttons	.12
Base LEDs	.13

Using the phone

Make an external call	.14
Preparatory dialling	.14
End a call	.14
Receiving calls	.14
Earpiece volume	.15
Handset ringer volume	.15
Secrecy	.15
Last number redial	.16
Paging	.16

Quickdial

Store a number in the Quickdial memory	.17
Dial a Quickdial number	.17
Delete a Quickdial number	.17

Caller Display and the calls list

View, dial and delete entries in the calls list	.18
Exit the calls list	.18

BT Studio 500 Twin additional handset

Making internal calls	.19
Receiving internal calls	.19
Transferring calls	.20

Using the answering machine

Switching the answering machine on/off	.21
Set date and time	.21
Play all messages	.22
Play new messages only	.22
Select and play outgoing message	.24
Record your own outgoing message(s)	.25
Delete your outgoing message(s)	.25
Adjust answer delay	.26
Record a memo	.26
Memory full during a call	.27
Call screening	.28

Remote access

Switch on your answering machine from another phone	.29
---	-----

Change the security PIN	29
Operating your answering machine from another phone	30
Outgoing message menu	32

Switchboard use

Switchboard compatibility	33
Switchboard external line access code . .	33
Recall	34

Help	35
-----------------------	-----------

General information

Safety	38
Cleaning	39
How many telephones can you have? . .	40
Guarantee	41
Returning your phone	42
R&TTE	43
Declaration of Conformance	43

Getting started

WARNING

Do not place your BT Studio 500 in the bathroom or other humid areas.

Handset range

The handset reception range from the base is up to 300m outdoors and up to 50m indoors, in ideal conditions.

Signal strength

The  icon on your handset indicates when you are in range. When it flashes, you are out of range.

IMPORTANT

The base station must be plugged into the mains power socket at all times.

Do not connect the telephone line until the handset is fully charged.

Which socket?



Power socket



Telephone line socket

If you have purchased the BT Studio 500 Twin please follow instructions **A** and **B**.

A Location

You need to place your BT Studio 500 close enough to a mains power and telephone socket so that the cables will reach.

The strength of the handset signal depends on where you site the base. Putting it as high as possible can help to provide the best signal. Make sure it is at least 1 metre away from other electrical appliances to avoid interference.

Setting up the base

1. Plug the power adaptor and telephone cables into the back of the base.

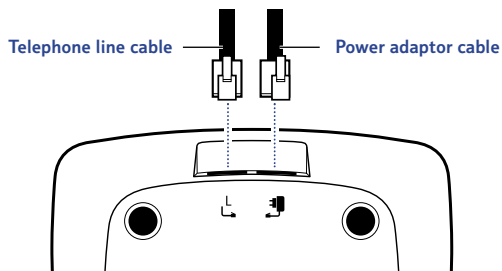

2. Plug the power adaptor into the mains wall socket and switch the power on. The green **Power** light on the base comes on.
3. Install the 2 x AAA rechargeable batteries supplied. Then slide the battery compartment cover into place.

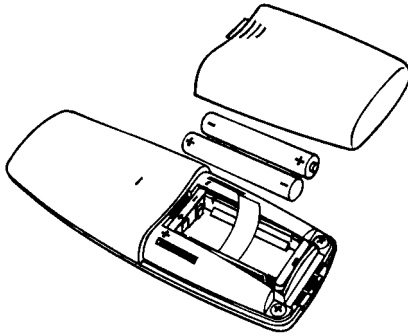

4. Charge the handset for at least 16 hours by placing the handset on the base. The red **Charging** light at the base comes on.

Once the batteries are partly charged the **Y** icon will flash briefly in the handset display and the **🔌** icon will appear.

Once the handset links with the base, the **Y** icon stops flashing.

Talk/Standby time

Under ideal conditions, the handset batteries should give about 14 hours talk time or 350 hours standby on a single charge. (The base must still remain plugged in to the mains and switched on at all times.)

Note that new batteries do not reach full capacity until they have been in normal use for several days.

Battery symbols

 – Battery charged

 – Battery low

Battery low warning

If the battery charge becomes low during a call you will hear a warning beep once every minute. If the battery runs out you will be cut off.

You will need to recharge the handset before using it.

During charging, the **🔌** icon will be displayed.

See 'Battery performance' on the following page.

8 Getting started

Battery performance

To keep your batteries in the best condition, leave the handset off the base for a few hours at a time. Running the batteries right down at least once a week will help them last as long as possible.

The charge capacity of rechargeable batteries will reduce with time as they wear out, giving the handset less talk/standby time. Eventually they will need to be replaced. New batteries are available from the BT Studio 500 Helpline on 0870 605 8047.

After charging your handset for the first time, subsequent charging time is about 6–8 hours a day. Batteries and handset may become warm during charging. This is normal.

5. After the handset is *fully charged*, the  icon will disappear from the display.

You can now plug the telephone line cord into the telephone wall socket.

Your BT Studio 500 is ready for use.

B BT Studio 500 Twin owners only



Location

You need to place your BT Studio 500 charger close enough to a mains power socket so that the cable will reach.

Setting up the charger

1. Plug the power adaptor cable into the underside of the charger.
2. Plug the power adaptor into the mains wall socket and switch the power on.
3. Install the 2 x AAA rechargeable batteries supplied into the second handset.

4. Place the handset in the charger and charge the handset for at least 16 hours. The red **Charging** light on the charger comes on.

Once the batteries are partly charged, the  icon will flash in the handset display and the  icon will appear.

Once the handset registers with the base, the  icon stops flashing.

Your BT Studio 500 Twin is ready for use.

BT Studio 500 additional handset

Your BT Studio 500 handsets are the same, so instructions throughout this guide apply to both.

Handset numbers

Once registered with the base, each handset will display its handset number, -1- and -2- respectively.

Getting to know your phone

Handset buttons

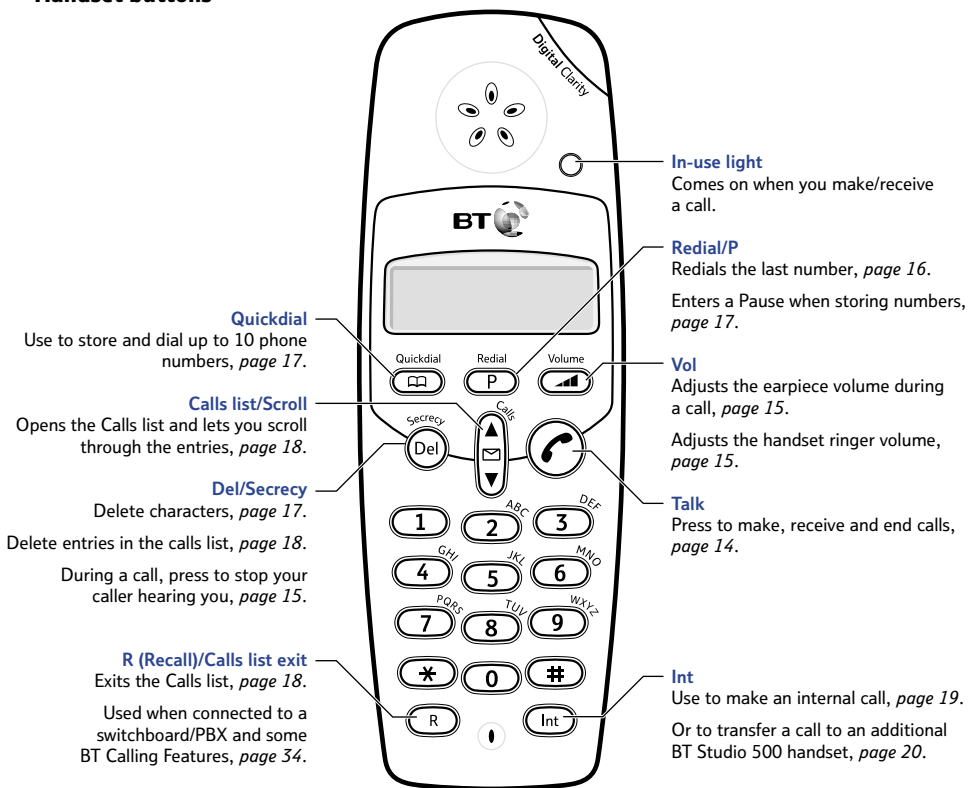

Sample standby screen – These are where the handset icons will appear.

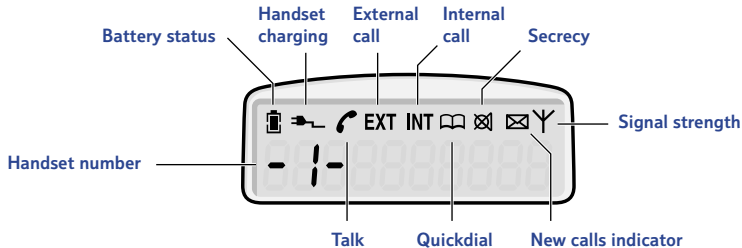

Handset display icons – These are the symbols you will see on your handset's screen.

 **Battery charged**

 **Battery low**
Indicates when the battery is low.

 **Handset charging**, page 7.

 **Talk**
Indicates a call is in progress, page 14.

EXT **External call**
Flashes when you receive an external call.
Stays on during the conversation, page 14.

INT **Internal call**
Flashes when you have a call from
another BT Studio 500 handset, page 19.

 **Quickdial**
Displayed when you are dialling or storing
numbers in the Quickdial directory, page 17.

 **Security on**, page 15.

 **New calls***
Flashes when you have new calls in the Calls list.
On when viewing the Calls list, page 18

 **Signal strength**
In range. Flashes when the handset is out of
range of the base.

* For these features to work you must subscribe to your Network Provider's Caller Display service.

12 Getting to know your phone

Base buttons

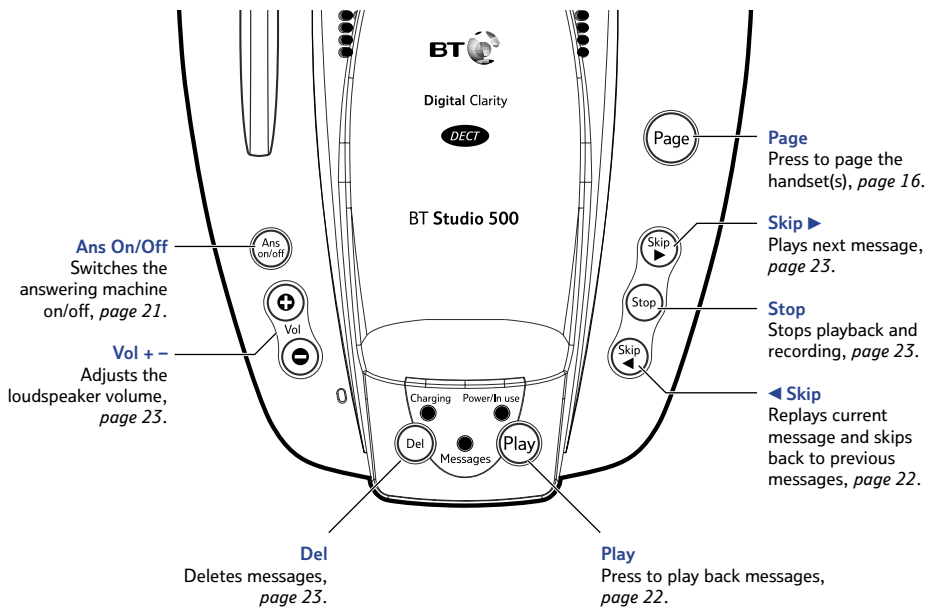

Base LEDs

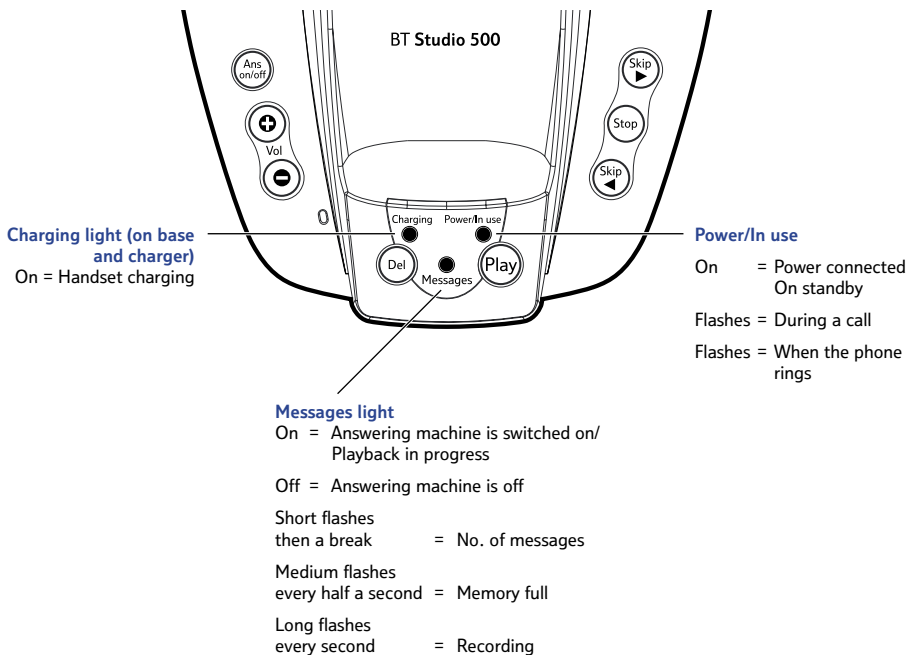

Using the phone



Dialling numbers quickly

Numbers can also be dialled using the Quickdial directory (*page 17*), and from the calls list (*page 18*).



Please note

The first digit of a telephone number you enter or receive via Caller Display, will not be shown on the screen. For example, the first 0 or 020 8123 4567 will not be displayed.

Make an external call

1. Press , listen for the dial tone then dial the number. The display shows the  icon.

Preparatory dialling

1. Enter the number first. If you make a mistake, press  to delete. Press  to dial.

End a call

1. Press  or place the handset back on the base.

Receiving calls

The base and handset will ring, the EXT icon flashes on the display.

1. Press  to answer the call or, if the handset is on the base, simply lift it and speak.

If you have subscribed to your network's Caller Display service, the caller's number will also be displayed.

See page 18 for more information.

Earpiece volume

1. During a call, press  button to scroll through the settings – Low, Medium, High – until you reach the volume level you prefer.



You can only adjust the earpiece volume *during a call*.

Handset ringer volume

1. Press  button to scroll through the settings – Low, Medium, High – until you reach the volume level you prefer. This level is set until you adjust it again.

Secrecy



During a call, you can talk to someone nearby without your caller hearing you.

1. During your call, press . Display shows the  icon. Your caller cannot hear you.
2. Press  again to resume your call.

16 Using the phone

Last number redial

Your handset automatically saves the last number you dialled, up to a maximum of 25 digits.

1. Press  then . The last number is displayed and dialled. You can add further digits if required.

Paging



You can alert handset users that they are wanted or locate a missing handset. Paging calls cannot be answered by a handset.

1. Press  on the base. The handset(s) will ring for 30 seconds.
2. Press any button on the handset to stop it ringing.



Quickdial

Store a number in the Quickdial memory



You can store up to 10 numbers for easy dialling. Each number can be up to 20 digits long.

1. Press . Display shows the  icon.
2. Select the location number (0–9) under which you want to store the number.
3. Enter the telephone number then press . You hear a confirmation beep.

Dial a Quickdial number

1. Press  then .
2. Press the location number (0–9) under which the entry is stored. The number is displayed and dialled.

Delete a Quickdial number

1. Press  then the location number (0–9) under which the phone number you want is stored.
2. Press  to delete.

You hear a warning beep if you try to enter more than 20 digits.

Deleting the last digit

If you make a mistake, press .

Cancel storing a number

Press  at any time.

Inserting a Pause

When storing a Quickdial number you can insert a Pause in the dialling sequence. This can be useful if your phone is connected to an internal switchboard. See page 33 for more information.

If you hear a beep when trying to dial a Quickdial number, it means no number has been stored.

Alternatively, you can overwrite a number by storing a new one in its place.

Caller Display and the calls list

IMPORTANT

To use Caller Display you must first subscribe to the service from your network provider. A quarterly fee is payable.

For more information on BT's Calling Features, call BT on Freephone 0800 800 150.

Caller information not available



Occasionally the telephone number of the caller is not available and cannot therefore be displayed.

In this case, your BT Studio 500 will show *CALL* instead of the caller's telephone number. The word *CALL* will not be stored in the calls list.

If the telephone number is longer than 10 digits, then the last 10 digits will be displayed.

If you subscribe to a Caller Display service you can see your caller's number on your handset's display (unless it has been withheld) before you answer the call.



Whether you answer a call or not, the caller's phone number is stored in the calls list.

New entries in the calls list are indicated by the  icon. When all the entries in the calls list have been viewed, the  icon will disappear.

Up to 10 phone numbers can be stored in the calls list. When the calls list is full, a new call replaces the oldest.

View, dial and delete entries in the calls list

1. Press  to open the calls list. The most recent caller's number is displayed.

2. Press  and  to scroll through the list.

Press  to dial the number displayed.

Press  to delete the number displayed.

Exit the calls list

1. Press  to exit the list.

BT Studio 500 Twin additional handset

The BT Studio 500 additional handset (available as part of the BT Studio 500 Twin package) is designed to provide an additional handset for your BT Studio 500.

With the BT Studio 500 Twin, you can make internal calls and transfer external calls between the two BT Studio 500 handsets.



The additional handset is pre-registered to your BT Studio 500 base. It is supplied with its own charger and must be charged for 16 hours before you can use it, see 'Getting Started' page 6 if you have not already done this.

Making internal calls

You can make internal calls between two BT Studio 500 handsets.

1. Press . The other handset will ring.

Receiving internal calls

1. When the handset rings, the display shows the INT icon. Press  to answer.
2. Press  again to end the call.

COMPATIBILITY

The BT Studio 500 additional handset is the **only handset** that can be used with your BT Studio 500 base.

BT Studio 500 phones are not GAP compatible. This means they cannot be registered to other DECT telephones.

20 BT Studio 500 Twin additional handset

Please note

If, after 30 seconds, the other handset has not answered, you are automatically re-connected to your caller.

Transferring calls

You can transfer an external call to the other BT Studio 500 handset.

During an external call:

1. Press **Int**. Your caller is put on hold and the other handset will ring.
2. When the handset answers, press **↻**. You can now tell the other user you are transferring the call.
3. Press **↻** again to transfer the call.

If the other handset does not answer, press **Int** to talk to your caller again.

Using the answering machine

Your BT Studio 500 answering machine uses voice prompts to guide you simply through its operation.

You can operate your answering machine from:

- The base.
- Remotely, from any other Touchtone® telephone, *see page 30*.

Before first using your answering machine you should set the correct date and time.

Switching the answering machine on/off

1. Press . The machine announces “Answer on” or “Answer off”. The messages light comes on when the answering machine is switched on.

Set date and time

You will need to set the date and time so that you know when each message was received.

Once a message has been played back, the machine will announce, for example, “Tuesday, four fifty, pm.”

1. Press *and hold*  until you hear the current setting.

Ready to record

The answering machine is pre-set to ON, so it's ready to record messages as soon as the base is plugged in. (Remember to charge the handset for at least 16 hours first).









Default date and time

The default date and time is Saturday, 12.01pm. If the power to the base is lost, the date and time will revert to this default setting. Your messages will be unaffected.

To check current date and time setting

Press the  button.

22 Using the answering machine

- Press  or  to scroll through the days and press  to select. The day is announced followed by the current hour setting.
- Press  or  to scroll through the hours and press  to select. The day and hour are announced followed by the current minutes setting.
- Press  or  to scroll through the minutes and press  to select. The newly set day and time is announced.

Listening to your messages



Play all messages

- Press . The number of messages is announced, and the oldest message is played first.

Play new messages only

- Press *and hold*  until you hear “*You have ‘n’ new messages.*” Your new messages will be played.



During playback:

-  Pause/resume playback.
-  Once repeats the current message, twice plays the previous message.

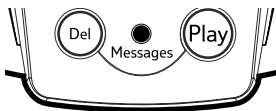
How many messages have I got?





The messages light on the base will flash when you have messages stored.

-  Once plays the next message, twice plays the message after that.
-  Deletes the current message and you hear “Message deleted”.
-  Stops playback, machine goes back to Answer On.

At the end of playback:

The machine announces “*End of messages. To delete all messages, press delete*”. The machine gives you 8 seconds during which you can press:

-  to delete *all* messages;
- or*
-  to *cancel* message deletion. This will also restore any messages you have selected individually for deleting.

Any messages not deleted are saved.

You will hear a beep to signal when 8 seconds has elapsed.

Cancel operation

Press  to end any operation at any time.

Loudspeaker volume

You can adjust the base loudspeaker volume at any time. In standby, you hear a beep which gets louder or softer.

Use the   buttons.

24 Using the answering machine

Personalise your OGM

To record your own outgoing message, see 'Record your own outgoing message', see page 25.

The answering machine is pre-set to Answer and Record mode.

Outgoing messages

The outgoing message (OGM) is the greeting a caller hears when the answering machine picks up their call. Your BT Studio 500 gives you a choice of two pre-recorded outgoing messages, one for Answer and Record and one for Answer Only.

Answer and Record

Callers hear the announcement and are able to leave a message for you.

The pre-recorded message is *“Hello, your call cannot be taken at the moment, so please leave your message after the tone.”*



Answer only

Callers hear an announcement but *cannot* leave a message.



The pre-recorded message is *“Hello, your call cannot be taken at the moment, and you cannot leave a message, so please call later.”*

Select and play outgoing message

1. Press *and hold*  until you hear *“Please select outgoing message.”*





2. For **Answer and Record**, press  or for **Answer Only** press . The selected message is played.

Record your own outgoing message(s)

1. At the base, press *and hold*  until you hear *“Please select outgoing message.”*
2. Press *and keep holding*  to select **Answer and Record** or press *and keep holding*  for **Answer Only**, until you hear *“Please speak after the tone. To end recording release the button.”*
3. After the beep, record your message. *Release* the button to end recording. Your new outgoing message is played back.

Your own outgoing message can be up to 3 minutes long.

Delete your outgoing message(s)

1. At the base, press *and hold*  until you hear *“Please select outgoing message.”*
2. Press  to select **Answer and Record** or press  for **Answer Only**. The selected message is played.
3. Press . The machine will revert to and play the pre-recorded version of the outgoing message you deleted.

You can only delete your own recorded outgoing message.

26 Using the answering machine

What is Time Saver?

Time Saver can save you the cost of call when you want to ring in to find out if you have new messages. (See 'Remote access', page 29).



If you have new messages, your answering machine answers after 2 rings. If you do not have new messages, it answers after 6 rings. This gives you a chance to hang up before the line is connected.

Answer delay

Answer delay is the number of times your BT Studio 500 rings before the answering machine picks up the call and starts playing the outgoing message.



You can choose between 2–9 rings, or Time Saver. The default setting is Time Saver.

Adjust answer delay

1. Press . The machine announces “*Answer Delay, Time Saver.*”
2. Press *and hold* . The machine announces the settings in turn. *Release* the button when you hear the answer delay you want. The new setting is announced.

Record a memo

You can record a message at the base which can be listened to and deleted just like any received message.

1. Press *and hold*  until you hear “*Please speak after the tone.*”
2. *Release*  to end recording.

Memory full

When the recording memory has been used up or a maximum of 59 messages have been received, no more messages can be taken. The machine will switch to Answer Only mode and play the message *“Hello your call cannot be taken at the moment and you cannot leave a message, so please call later.”*

You must delete existing messages before new ones can be taken.

Memory full during a call

When there is approximately 30 seconds of recording memory left, the caller will hear *“Please complete your call within 30 seconds.”*

If the memory runs out or the maximum message length of 3 minutes is reached while a caller is leaving a message, they will hear *“Thank you for calling”* before the call is ended.

When the answering machine memory is full the message light on the base will flash steadily every half a second.

28 Using the answering machine

Loudspeaker volume

Use the  buttons.

Call screening

When the answering machine is switched on, you can use the loudspeaker to listen to callers leaving their messages.

1. Press  to interrupt and speak to the caller. Any message they have already recorded will be kept.

Power failure

If the mains power is lost, your answering machine will keep many personalised settings when it is switched on.

The settings after a power failure will be:

Outgoing message	As last set by you
Answer Delay	As last set by you
On/Off	As last set by you
Message indicator	Flashing, if any messages have been recorded
Messages	Saved
Volume	Level 5
PIN	000
Day/time	12:01 PM Saturday

Remote access

You can operate your answering machine from any modern Touchtone® phone by calling your BT Studio 500 and entering a 3-digit security PIN.

Using a PIN code prevents other people from accessing your machine without permission.





Switch on your answering machine from another phone

If you forget to switch on your answering machine, you can do it from another phone.

1. Dial your phone number and let it ring. After 20 rings, your answering machine will switch on.

Change the security PIN

Your 3-digit PIN lets you access your answering machine from another phone. It should be changed from the original setting of **000**.

1. Press . The current PIN is announced.
2. Press *and hold* . The machine announces “Security code setting” and then “First digit.”
3. Press  or  to change the first digit, then press  to confirm. You then hear “Second digit.”

IMPORTANT

You should change the security PIN from the original setting of 000.

If you make a mistake when entering your PIN you will hear *“Incorrect security code, please enter your security code.”* and enter the correct PIN.

If you make a mistake again, you will hear *“Thank you for calling.”* and the machine will hang up.

If you leave the machine on pause for over 1 minute it will announce *“Thank you for calling.”* and hang up.

Repeat this step to set and confirm the second and third digits.

4. Press **[OK]** to confirm. Your machine announces *“Your security code is...”*.

Operating your answering machine from another phone

1. Dial your number. When you hear the outgoing message, press **[*]**.
2. The machine announces *“Please enter your security code”*, use the phone’s keypad to enter your 3-digit PIN. The machine announces *“You have ‘n’ new messages”* and they are played.
3. Using the phone’s keypad you can replay, pause, skip or delete messages and adjust settings.
 - 1 To hear the menu of options.
 - 2 To play/pause your messages.
 - 3 To play new messages only.
 - 4 Once to repeat the current message;
Twice to skip back to previous messages.
 - 5 To delete the current message.

- 6 Once to skip to the next message;
Twice to skip to the message after.
- 7 To switch the answering machine off.
- 8 To play the outgoing message menu, see
'Outgoing message menu' on the following page.
- 9 To set a new security PIN. Follow the voice
prompts.
- 0 To set the day and time. Follow the voice prompts
when you are asked to *"Enter the Day and Time
after the tone"*.
Enter the day: 1= Sunday to 7 = Saturday.
Enter hours then minutes using the 24-hour clock,
e.g. **1340** for 1:40pm. Then press **#**.
To delete all messages, press **5** when prompted
at the end of playback.

4. Hang up the phone to end remote access.

Outgoing message menu

You can record an outgoing message (OGM) and set the message type from another telephone.

1. During message playback, press **8**. The machine announces *“Outgoing message menu.”* which is:
 - 2 To play OGM.
 - 3 To record Answer and Record OGM.
 - 4 To record Answer Only OGM.
 - 5 To select Answer and Record OGM.
 - 6 To select Answer Only OGM.
 - 8 To hear OGM menu again.
 - 1 To hear main menu again.
2. When you have selected the option you want, follow the simple voice prompts.

Switchboard use

Switchboard compatibility

This product is intended for use within the UK for connection to public telephone network and compatible switchboards, which support tone dialling and timed break recall. If in doubt please consult your network service provider.

Switchboard external line access code

You may need to enter an access code (e.g. 9) in order to get an outside line. So that the switchboard has time to pick up an outside line, you may also need to add a Pause after the access code.

A Pause lasts 3 seconds. You can Pause dialling at any time by pressing the **P** button.

To insert an access code followed by a pause

1. Begin storing a number (see 'Quickdial' on page 17).
2. Enter the access code and where a pause is needed, press **P**. You can then continue storing the remaining part of the phone number.

Pause

You may also need to insert a pause when storing international dialling codes, charge card numbers and with other tele-banking facilities.

Recall

The  button is used when connected to certain switchboards, e.g. to transfer calls, and for some BT Calling Features or those services available via your network provider.

Help

Many common problems are caused by the telephone and power cables being incorrectly connected, not connected at all, or the power being turned off.

Please check that your BT Studio 500 has been correctly set up, *see page 6*, before ringing the BT Studio 500 Helpline.

Phone

Problems	Possible cause
No display appears.	The batteries may be flat or dead. Recharge or replace the batteries, <i>see page 7</i> .
No dial tone.	Is the telephone line cord plugged into the telephone wall socket? Check that the base station is connected to the mains power and switched on.
You cannot link up with the base station.	Is the display flashing the Y icon? The mains power cable may not be connected at the base or switched on. Are you in range of the base? Move closer to the base. The batteries could be low or flat. Recharge or replace the batteries.

No ring on the handset.	Check that the base station is plugged into the phone socket and that the mains power is switched on. The ringer volume may be set too low for you. <i>See page xx</i> to adjust the volume.
Buzzing noise on my radio, TV, computer or hearing aid.	Sometimes your BT Studio 500 can interfere with other electrical equipment if it is placed too close. It is recommended that you place your BT Studio 500 at least one metre away from such appliances to avoid any risk of interference.
The handset charger is not working.	The power adaptor is properly plugged into the charger. Your handset has slotted correctly into the charger. The batteries are fitted correctly into the handset. The base is plugged into a working socket and the socket is switched on. Are you using the correct power adaptor?
Caller's number is not displayed even though you have subscribed to a Caller Display service.	The number has been withheld by the caller, is unavailable or is an international call, <i>see page 18</i> .

Answering machine

Answering machine does not record any messages or announcements.	The memory may be full. Play and delete old messages, <i>see pages 22 and 23.</i>
Answering machine messages do not have the correct day and time added.	Set the correct day and time, <i>see page 21.</i>
Cannot access your messages from another phone.	Change the base security PIN to allow you to access your messages from another phone.

BT Studio 500 Helpline 0870 605 8047

Call the dedicated BT Studio 500 Helpline:

- if you are having difficulties using your BT Studio 500;
- if you need replacement batteries or mains power lead.

Lines open 9am – 5.30pm,
Monday to Friday.

9.30am – 2.30pm, Saturdays

BT Accessories and Replacement Items

For a full range of accessories and replacement items for BT products please call 0870 240 5522, or visit:



General information

IMPORTANT

This equipment is not designed for making emergency telephone calls when the power fails. Alternative arrangements should be made for access to emergency services.

Safety

General

- Only use the power supply included with the product. Using an unauthorised power supply will invalidate your guarantee and may damage the telephone. The item code for the mains power supply is 872260.
- For the handset use only approved Nickel Metal Hydride (NiMH) rechargeable batteries. Never use other batteries or conventional alkaline batteries. They could lead to a short circuit or destroy the battery casing. Recommended batteries should have a power rating of 550mAh 1.2V. Batteries are available from the BT Studio 500 Helpline 08706 058 047.
- Do not open the handset or base. This could expose you to high voltages or other risks. Contact the helpline for all repairs.
- Radio signals transmitted between the handset and base may cause interference to hearing aids.
- It is recommended that advice from a qualified medical expert be sought before using this product in the vicinity of emergency/intensive care medical equipment.
- It is recommended that if you have a pacemaker fitted you check with a medical expert before using this product.

- Your product may interfere with other electrical equipment, e.g. TV and radio sets, clock/alarms and computers if placed too close. It is recommended that you place your product at least one metre away from such appliances to minimise any risk of interference.
- Never dispose of batteries in a fire. There is a serious risk of explosion and/or the release of highly toxic chemicals.

Cleaning

Simply clean the handset and base with a damp (not wet) cloth, or an anti-static wipe. Never use household polish as this will damage the product. Never use a dry cloth as this may cause a static shock.

Environmental

- Do not expose to direct sunlight.
- The product may heat up when the battery pack is being recharged. This is normal. However, we recommend that you do not place the product on antique/veneered wood to avoid damage.
- Do not stand your product on carpets or other surfaces which generate fibres, or place it in locations preventing the free flow of air over its surfaces.
- Do not submerge any part of your product in water and do not use it in damp conditions, such as bathrooms.
- Do not expose your product to fire, explosive or other hazardous conditions.

40 General information

- There is a slight chance that your phone could be damaged by an electrical storm. We recommend that you unplug the power and telephone line cord for the duration of the storm.

Technical information

How many telephones can you have?

All items of telephone equipment have a Ringer Equivalence Number (REN), which is used to calculate the number of items which may be connected to any other telephone line. Your BT Studio 500 has a REN of 1. A total REN of 4 is allowed. If the total REN of 4 is exceeded, the telephone may not ring.

With different telephone types there is no guarantee of ringing, even when the REN is less than 4.

- Only use the approved power supply, item code 872260. If you have also purchased the BT Studio 500 Twin, for the charger use only item code 003313,
- Only use approved AAA NiMH rechargeable batteries.

Guarantee

Your BT Studio 500 digital cordless telephone is guaranteed for a period of 12 months from the date of purchase.

Subject to the terms listed below, the guarantee will provide for the repair of, or at BT's or its agent's discretion the option to replace the BT Studio 500, or any component thereof, (other than batteries), which is identified as faulty or below standard, or as a result of inferior workmanship of materials. Products over 28 days old from the date of purchase may be replaced with a refurbished or repaired product.

For your records

Date of purchase:

Place of purchase:

Serial number:

For guarantee purposes proof of purchase is required so please keep your receipt.

The conditions of this guarantee are:

- The guarantee shall only apply to defects that occur within the 12 month guarantee period.
- Proof of purchase is required.
- The equipment is returned to BT or its agent as instructed.
- This guarantee does not cover any faults or defects caused by accidents, misuse, fair wear and tear, neglect, tampering with the equipment, or any attempt at adjustment or repair other than through approved agents.
- This guarantee does not affect your statutory rights.

42 General information

Within the 12 month guarantee period:

If you experience difficulty using the product, prior to returning it, please read the 'Help' section beginning on page 35, or contact the BT Studio 500 Helpline on 0870 605 8047, 9am–5.30pm, Monday to Friday and 9.30am–2.30pm, Saturday.

In the unlikely event of a defect occurring, please follow the Helpline's instructions for replacement or repair.

Outside of the 12 month guarantee period:

If your product needs repair after the guarantee period has ended, the repair must meet the approval requirements for connection to the telephone network. We recommend that you contact BT's approved repair agent, TecLogic on 01672 564444 or a local qualified repairer.

Returning your phone

If the Helpline is unable to remedy your problem they will ask you to return the product. Where possible, pack the product in its original packaging. Please remember to include all parts, including the line cords, power supply units and the original batteries. (Please note that we cannot take responsibility for goods damaged in transit.) Please obtain and keep proof of posting from the Post Office.

R&TTE

This product is intended for use within the UK for connection to the public telephone network and compatible switchboards.

This equipment complies with the essential requirements for the Radio Equipment and Telecommunications Terminal Equipment Directive 1999/5/EC.

Declaration of Conformance

Hereby, Suncorp Technologies, declares that this BT Studio 500 is in compliance with the essential requirements and other relevant provisions of Directive 1999/5/EC.

The Declaration of Conformance for the BT Studio 500 is published on the website:
<http://www.suncorptech.com/bt>

Visit us at www.bt.com



Offices worldwide

The telecommunications services described in this publication are subject to availability and may be modified from time to time. Services and equipment are provided subject to British Telecommunications plc's respective standard conditions of contract. Nothing in this publication forms any part of any contract.

© British Telecommunications plc 2003.
Registered Office: 81 Newgate Street, London EC1A 7AJ.
Registered in England No. 1800000.
BT Studio 500/BT Studio 500 Twin (08/03) 3
Designed and produced by The Art & Design Partnership Ltd.
Printed in China

