

REVO *S* 1PH

SOLID-STATE RELAY

FROM 60 TO 210 A

00016



CD Automation S.r.l.

Via Picasso 34/36 - 20025 - Legnano (MI) - ITALY

Tel +39 0331 577479 - Fax +39 0331 579479

E-Mail: info@cdautomation.com - WEB: www.cdautomation.com

1 Important warning for safety	5
2 Basic Connections	6
3 Identification and Order Code	7
3.1 Identification of the unit	7
3.2 Order Code	8
4 Technical Specifications	9
4.1 General features:	9
4.2 Input features:	9
4.3 Output features(power device):	9
4.4 Fan Specification (only from 120 to 210A)	9
5 Installation	10
5.1 Environmental installation conditions	10
5.2 Derating Curve	10
5.3 Dimensions and Weight	11
5.4 Fixing holes	11
6 Wiring instructions	12
6.1 Power cable torque (suggested)	12
6.2 Cable dimensions of the Command Terminals	12
6.3 Cable dimensions of the Earth (suggested)	12
6.4 Power Terminals	13
6.5 Command Terminals	13
6.5.1 SSR Input only terminal blocks M1	13
6.5.2 Terminal block M1 for Analog Input or SSR input with HB.....	13
6.6 Fan Supply (only from 120 to 210A)	13
6.7 Connection Diagram for Single-phase	14
7 Led status and Alarms	15
8 Heater Break alarm and SCR short circuit (HB Option only)	15
8.1 HB Alarm contact	16
9 Input setting	17
9.1 Input calibration procedure	18
10 Firing type	19
10.1 Zero Crossing (ZC) with SSR input	19
10.2 Burst Firing (BF) with Analog Input	19
10.3 Burst Firing settings	20
11 Internal Fuse	21
The warranty of thyristor is null if no proper fuses are used.	21
11.1 Internal Fuse	21
11.2 Fuses Replacement	21
12 Maintenance	22
12.1 Trouble Shooting	22
12.2 Warranty condition	22

CD Automation s.r.l.**Controllers, Drives & Automation**

Via Picasso, 34/36 - 20025 Legnano (MI)- Italia

P.I. 08925720156 -Tel. (0331) 577479 - Fax (0331) 579479

Internet : www.cdautomation.com - E-MAIL: info@cdautomation.com

Dichiarazione di Conformità

CE Declaration of Conformity

PRODUTTORE:

PRODUCT MANUFACTURER:

CD Automation S.R.L.

INDIRIZZO:

ADDRESS:

Via Pablo Picasso 34//36

20025 Legnano (Mi)

Italia

Dichiara che il prodotto:
Declare that the product:

RevoS, 1ph da 60 a 210A

SODDISFA I REQUISITI DELLA NORMA :

Specifica di sicurezza	EN60947-1	:2008
	EN60947-4-3:2001	
Specifica sulle emissioni	EN60947-4-3:2000	
Specifica sulle Immunità	EN60947-4-3:2000	

FULFILLS THE REQUIREMENTS OF THE STANDARD:

Electrical safety Standard	EN60947-1	:2008
	EN60947-4-3:2001	
Generic Emission standard	EN60947-4-3:2000	
Generic Immunity standard	EN60947-4-3:2000	

CDAutomation dichiara che I prodotti sopra menzionati sono conformi alla direttiva
 CDAutomation declares that The products above mentioned they am conforming to the directive

EMC 2004/108/CEE e alla direttiva Bassa Tensione (low Voltage) **2006/95/CEE**

DESCIZIONE DEL PRODOTTO:
 PRODUCT DESCRIPTION:

Unità di controllo potenza elettrica
 Elettric power controll

UTILIZZO:
 SCOPE OF APPLICATION:

Controllo processi termici
 Thermal controll process

Data di emissione: 20/04/2010
 Issued on: 20/04/2010

Amministratore Unico e
 Legale Rappresentante
Claudio Brizzi

A handwritten signature in black ink, appearing to read 'C. Brizzi'.



1 Important warning for safety



The Thyristor unit are integral part of industrial equipments.
When it is supply, the Thyristor unit is subject to dangerous tensions. Don't remove the plastic cover.
Don't use this unit in aerospace and nuclear application.

Electric Shock Hazard (Rischi di scosse elettriche, Risque de choque électrique)

When thyristor unit has been connected to main supply voltage and is switched off, before to touch it be secure that the unit is isolated and wait at least one minute to allow discharging internal capacitors.

Thus be secure that:

- access to thyristor unit is only permitted to specialised personnel;
- the authorised personnel must read this manual before to have access to the unit;
- the access to the unit must be denied to unauthorised personnel.

Important warnings (Avvertenze importanti, attention)

During the operations with units under tension, local regulations regarding electrical installation should be rigidly observed:

- Respect the internal safety rules.
- Don't bend components to maintain insulation distances.
- Protect the units from high temperature humidity and vibrations.
- Don't touch components to prevent electrostatic discharges on them.
- Verify that the size is in line with real needs.
- To measure voltage current etc. on unit, remove rings and other jewels from fingers and hands.
- Authorized personnel that work on thyristor unit under power supply voltage must be on insulated board

This listing does not represent a complete enumeration of all necessary safety cautions

Protection (Protezione, Protection)

The unit have IP20 protection rating as defined by the specific international. Is necessary consider the place of installation.

Earth (Messa a terra, Terre)

For safety, the Thyristor unit with isolated heat-sink must be connected to earth.

Earth impedance should be correspondent to local earth regulation. Periodically the earth efficiency should be inspected.

Electromagnetic compatibility (Compatibilità elettromagnetica, Compatibilité électromag.)

Our thyristor units have an excellent immunity to electromagnetic interferences if all suggestions contained in this manual are respected. In respect to a good Engineering practice, all inductive loads like solenoids contactor coils should have a filter in parallel

Emissions (Emissioni, Emission)

All solid-state power controllers emit a certain amount of radio-frequency energy because of the fast switching of the power devices. The CD Automation's Thyristor unit are in accord with the EMC norms, CE mark.

In most installations, near by electronic systems will experience no difficulty with interference. If very sensitive electronic measuring equipment or low-frequency radio receivers are to be used near the unit, some special precautions may be required. These may include the installation of a line supply filter and the use of screened (shielded) output cable to the load.



2 Basic Connections

Single phase wiring with resistive load

$$I = \frac{P}{V}$$

V = Nominal voltage of the load

I = Nominal current of the load

P = Nominal power of the load

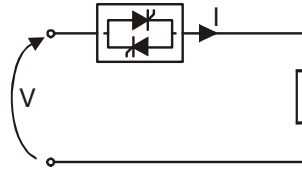

Open Delta wiring with resistive load

$$I = \frac{P}{3V}$$

V = Nominal voltage of the load

I = Nominal current of the load

P = Nominal power of the load

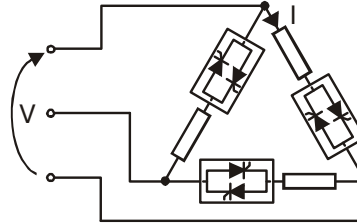

3 Identification and Order Code

3.1 Identification of the unit



Caution: Before to install, make sure that the Thyristor unit have not damages. If the product has a fault, please contact the dealer from which you purchased the product.

The identification's label give all the information regarding the factory settings of the Thyristor unit, this label is on the unit, like represented in figure. Verify that the product is the same thing as ordered .

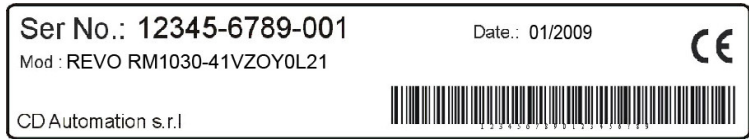

3.2 Order Code

1	2	3	4	5	6	7	8	9	10	11	12	13	14	15	16
REVOS	S	1	-	-	-	-	-	-	-	-	-	-	-	-	-
8 Aux. Voltage supply															
4, 5, 6		Current		Numeric code		Description code		Numeric code		11 Control Mode		14 Approvals		Numeric code	
		60A		0 6 0		No Aux. Voltage, without HB and/or without Analog Input		0		Open Loop		CE EMC For European Market		0	
		90A		0 9 0		12-24V ac-dc 70mA, with HB and/or Analog Input		4		Fuse & Option		cUL For American Market, pending		L	
		120A		1 2 0						Fixed Fuses IF					
		150A		1 5 0						Fixed Fuses +CT					
		180A		1 8 0						Fixed Fuses +CT +HB					
		210A		2 1 0											
9 Input															
7		Max Voltage		Numeric code		Description code		Numeric code		13 Fan Voltage		15 Manual		Numeric code	
		480V		4		SSR		S		No Fan ≤ 90A		None		0	
		600V		6		0:10V dc		V		Fan 110V > 90A		Italian Manual		1	
						4:20mA		A		Fan 220V > 90A		English Manual		2	
										Std Version		German Manual		3	
												French Manual		4	
10 Firing															
Description code		Numeric code		10 Firing		Description code		Numeric code		16 Version		Description code		Numeric code	
Zero Crossing ZC		Z				Burst Firing				Std with fixed Fuses				1	
4 Cycles On at 50% Power Demand		4 (1)				Burst Firing									
8 Cycles On at 50% Power Demand		8 (1)				Power Demand									
16 Cycles On at 50% Power Demand		6 (1)				Power Demand									

LEGEND

- IF = Internal Fixed Fuse
- CT = Current Transformer
- HB = Heater Break Alarm

Note (1): Available only with Analog input

4 Technical Specifications

4.1 General features:	
Cover and Socket material:	PolymericV2
Utilization Category	AC-51 AC-55b
IP Code	20
Method of Connecting	Single Phase Load
Auxiliary voltage:	12÷24V dc/ac (max 70mA)If requested
Relay output for Heater Break Alarm (only with HB option):	0.5A a 125VAC

4.2 Input features:	
Logic input SSR:	5 ÷ 30Vdc 9mA Max (ON ≥ 5Vdc OFF < 4Vdc)
Logic input SSR with HB option:	4 ÷ 30Vdc 5mA Max (ON ≥ 4Vdc OFF < 1Vdc)
Analog Input V:	0 ÷ 10Vdc (15KΩ)
Analog Input A:	4 ÷ 20mA (100Ω)
Digital Input calib. (only with HB option):	12 ÷ 24V dc/ac (max 4mA)

4.3 Output features(power device):

Current	Nominal Voltage range (Ue)	Repetitive peak reverse voltage (Uimp)		Latching current	Max peak one cycle	Leakage current	I ² T value max	Frequency range	Power loss	Isolation Voltage (Ui)
		(480V)	(600V)							
60	24÷600	1200	1600	450	1000	15	4750	47÷70	65	2500
90	24÷600	1200	1600	450	2000	15	19100	47÷70	84	2500
120	24÷600	1200	1600	450	1540	15	11300	47÷70	138	2500
150	24÷600	1200	1600	450	2000	15	19100	47÷70	162	2500
180	24÷600	1200	1600	300	4800	15	108000	47÷70	178	2500
210	24÷600	1200	1600	300	5250	15	128000	47÷70	202	2500

4.4 Fan Specification (only from 120 to 210A)

Supply: 230V Standard	Input Power 16W (1 Fan)
Supply: 115V Option	Input Power 14W (1 Fan)

5 Installation

Before to install, make sure that the Thyristor unit have not damages.

If the product has a fault, please contact the dealer from which you purchased the product. Verify that the product is the same thing as ordered.

The Thyristor unit must be always mounted in vertical position to improve air cooling on heat-sink.

Maintain the minimum distances in vertical and in horizontal as represented.

When more unit has mounted inside the cabinet maintain the air circulation like represented in figure.

Sometimes is necessary installing a fan to have better air circulation.

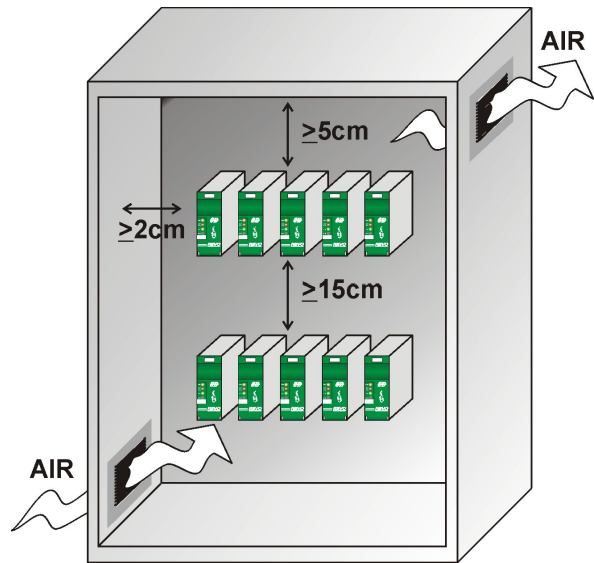

5.1 Environmental installation conditions

Ambient temperature	0-40°C at nominal current. Over 40°C use the derating curve.
Storage temperature	-25°C a 70°C
Installation place	Don't install at direct sun light, where there are conductive dust, corrosive gas, vibration or water and also in salty environmental.
Altitude	Up to 1000 meter over sea level. For higher altitude reduce the nominal current of 2% for each 100m over 1000m
Humidity	From 5 to 95% without condense and ice
Pollution Level	Up to 2nd Level ref. IEC 60947-1 6.1.3.2

5.2 Derating Curve

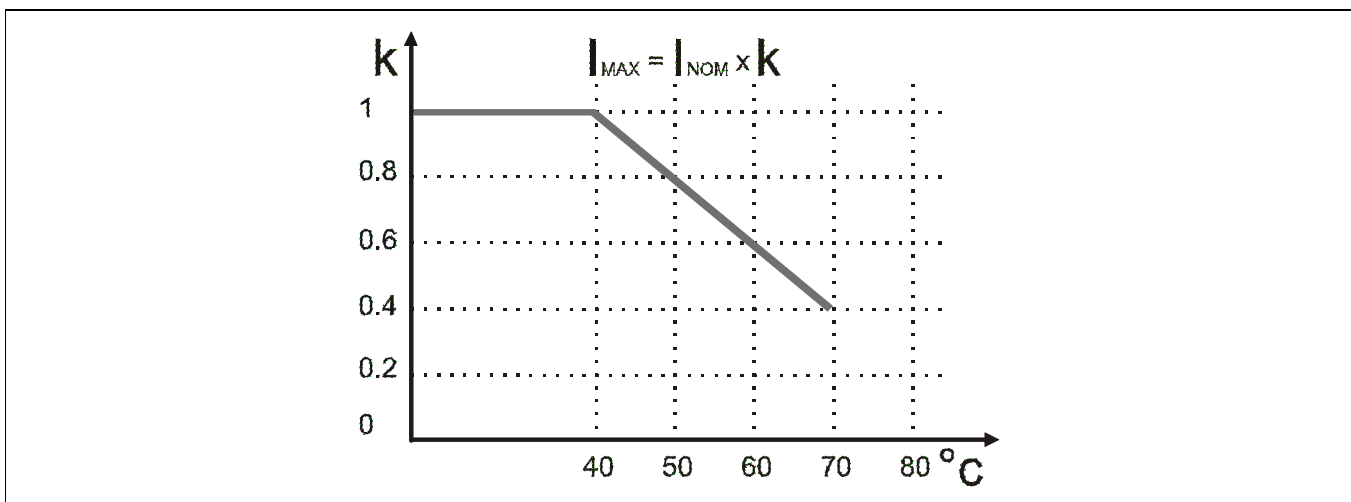

5.3 Dimensions and Weight

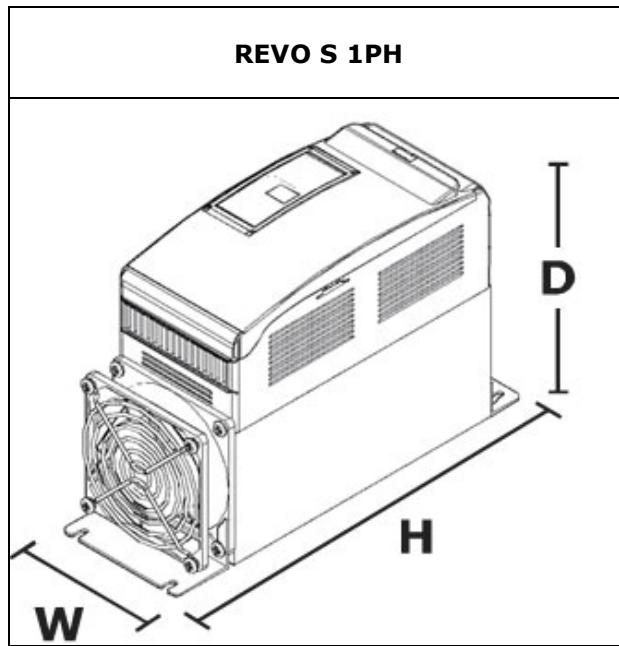

Size	W(mm)	D(mm)	H(mm)	Weight (kg)
1PH (60-90A no Fan)	93	170	269	3,4
1PH (120-210A with Fan)	93	170	273	3,6

5.4 Fixing holes

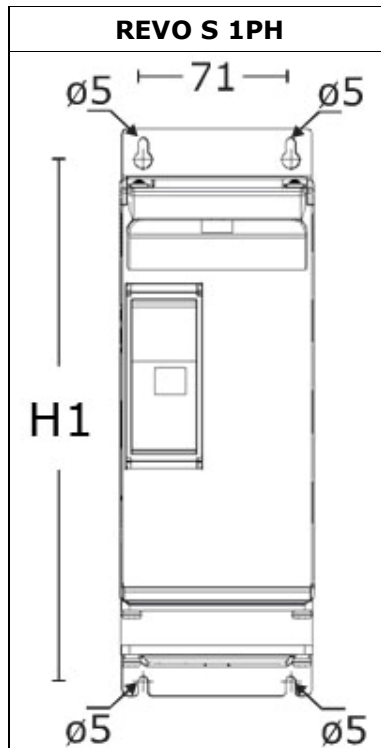

	1PH (60-90A no Fan)	1PH (120-210A with Fan)
H1	256	260

6 Wiring instructions

The Thyristor unit could be susceptible to interferences lost by near equipments or by the power supply, for this reason in accord to the fundamental practices rules is opportune take some precautions:

- The coil contactor, the relays and other inductive loads must be equipped with opportune RC filter.
- Use shielded bipolar cables for all the input and output signals.
- The signal cables must not be near and parallel to the power cables.
- Local regulations regarding electrical installation should be rigidly observed.

Use copper cables and wires rated for use at 75°C only.

6.1 Power cable torque (suggested)

Type	Connector Type	Torque Lb-in (N-m)	Wire Range mm ² (AWG)	MAX Current Terminals	Wire Terminals UL Listed (ZMVV)
060 090 120	Screw M6	70.8 (8.0)	1	150	Fork/Spade Terminal Copper Tube Crimp.Lug
150 180 210	Screw M8	265 (30.0)	1 3/0	250	Copper wire Compact (Solid) Stranded

6.2 Cable dimensions of the Command Terminals

0.5mm² (AWG 18)

6.3 Cable dimensions of the Earth (suggested)

16 mm² (AWG 6) up to 120A

25 mm² (AWG 4) up to 210A

TOP VIEW

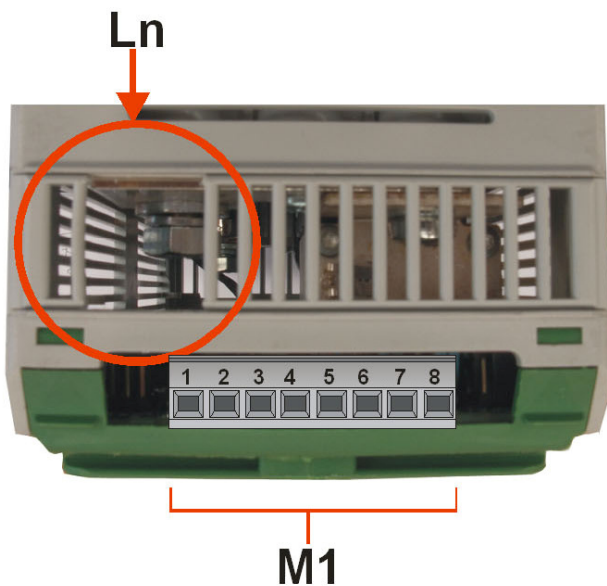

DOWN VIEW

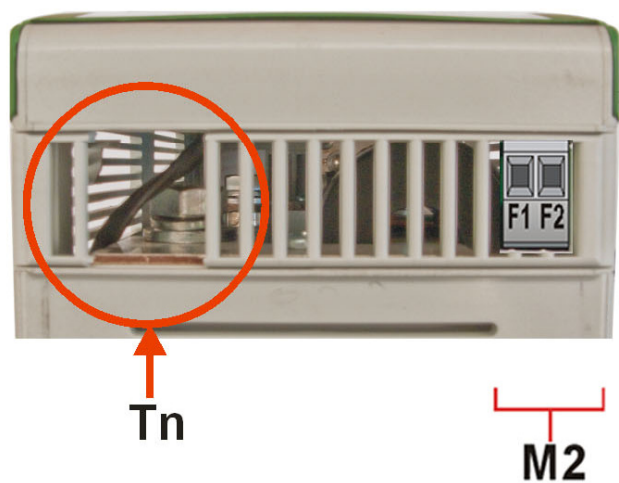

6.4 Power Terminals



Warning: Before connecting or disconnecting the unit check that power and control cables are isolated from voltage sources.

Terminal	Description
L1	Line Input Phase 1
T1	Load Output Phase 1

6.5 Command Terminals



Warning: Before connecting or disconnecting the unit check that power and control cables are isolated from voltage sources.

6.5.1 SSR Input only terminal blocks M1

Terminal M1	Description
1	Not connected
2	Not connected
3	Not connected
4	Not connected
5	Not connected
6	Not connected
7	- Input SSR
8	+ Input SSR

6.5.2 Terminal block M1 for Analog Input or SSR input with HB

Terminal M1	Description
1	Aux - Voltage Supply for electronic boards 12-24V AC/DC
2	Aux - Voltage Supply for electronic boards 12-24V AC/DC
3	- Cal Ext. 12/24Vdc
4	+ Cal Ext. 12/24Vdc
5	C -Common contact relay alarm output (see HB Alarm contact for config.)
6	NC\NO -Normally Close\Open contact alarm relay output (see HB Alarm contact for config.)
7	- Control Input (SSR/0-10Vdc/4-20mA)
8	+ Control Input (SSR/0-10Vdc/4-20mA)

6.6 Fan Supply (only from 120 to 210A)

Terminal M2	Description
F1	Fan supply (230V standard - 115V option)
F2	Fan supply (230V standard - 115V option)



Caution: this procedure must be performed only by qualified persons.

6.7 Connection Diagram for Single-phase

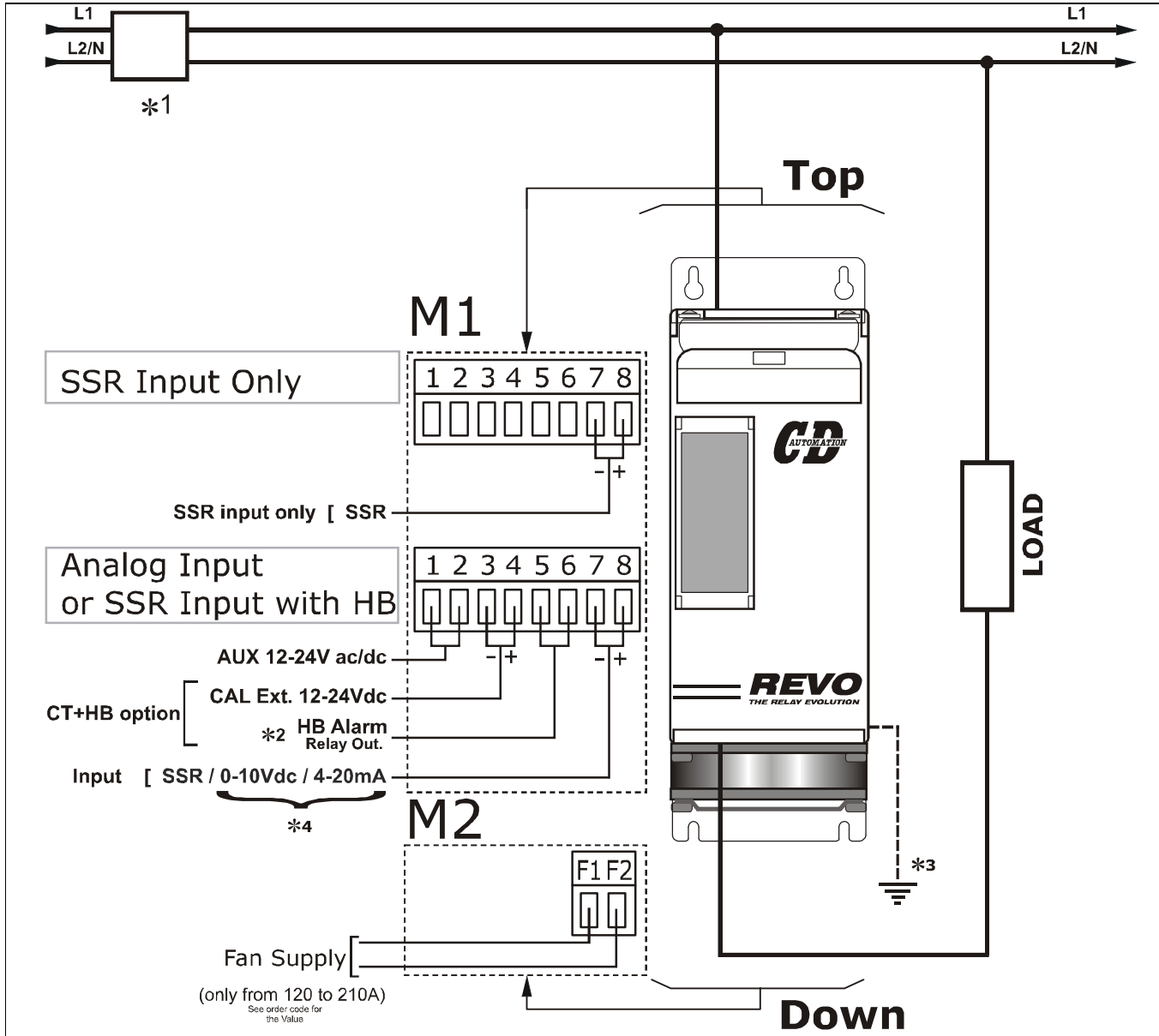

- *1 A suitable device must ensure that the unit can be electrically isolated from the supply (electromagnetic circuit breaker or by fuse isolator), this allows the qualified people to work in safety.
- *2 Only for the HB option See par. "Heater break Alarm and SCR short circuit"
- *3 The heat-sink must be connected to the earth.
- *4 Only for the Analog Input option, the analog input isn't isolated from Aux Supply a series connection between analogue inputs of the units is not possible.
With AC Aux supply it's not possible to connect the zero terminal of Analogue Input to the earth.
With DC Aux supply it is not possible to connect the zero of the power supply with the zero of analog input

7 Led status and Alarms

LED	STATUS	DESCRIPTION
H.B. S.C.	LED OFF	Load OK
	LED ON (Yellow)	Load Fault (only with HB option)
	LED ON (Red)	SCR short circuit (only with HB option)
ON	LED OFF	Load is NOT powered
	LED ON (Green)	Load is powered

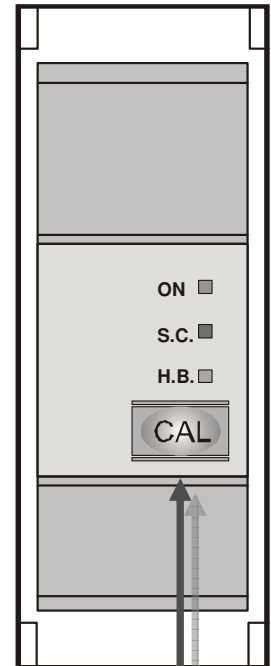

8 Heater Break alarm and SCR short circuit (HB Option only)



Caution: to work properly the load must be powered at least about 160msec.

The Heater Break circuit read the load current with an Internal current transformer (C.T.). Minimum current is 10% of the current transformer size. If load current is below this value the Heater Break Alarm doesn't work properly.

Heater break Calibration procedure

An automatic function sets the Heater Break Alarm.

The auto setting function can be activated using the "CAL" button on front unit, or supply with 12-24Vdc the digital input "Cal Ext." (See Connection Diagram).

The Heater Break calibration procedure is performed in this way:

- The Unit gives the maximum voltage output
- all LEDs are on, this means that calibration procedure is active
- The current value is stored in memory
- After about 15 second the unit comes back to the initial situation

If load current decreases for partial or total load failure (sensitivity 20%) the yellow LED HB become ON and alarm relay change status.

If the unit is still in conduction with no input signal (LED green OFF) it means that there is a short circuit on thyristors and red LED (SC) become ON.

If the load has been changed the Heater Break calibration procedure must be done again

8.1 HB Alarm contact

The Revo unit with HB option, is supplied with Heater Break alarm contact normally opened (NO):

- In normal conditions (without alarm) and with auxiliary power supply, the contact to the terminals has opened (relay coil energized).
- In alarm condition or without auxiliary power supply the contact to the terminals is closed (relay coil not energized).

if you wish to change the alarm contact open the cover of the module and set the jumper as shown in the next page .



Warning: Before operate, be sure that power and control cables are isolated from voltage sources

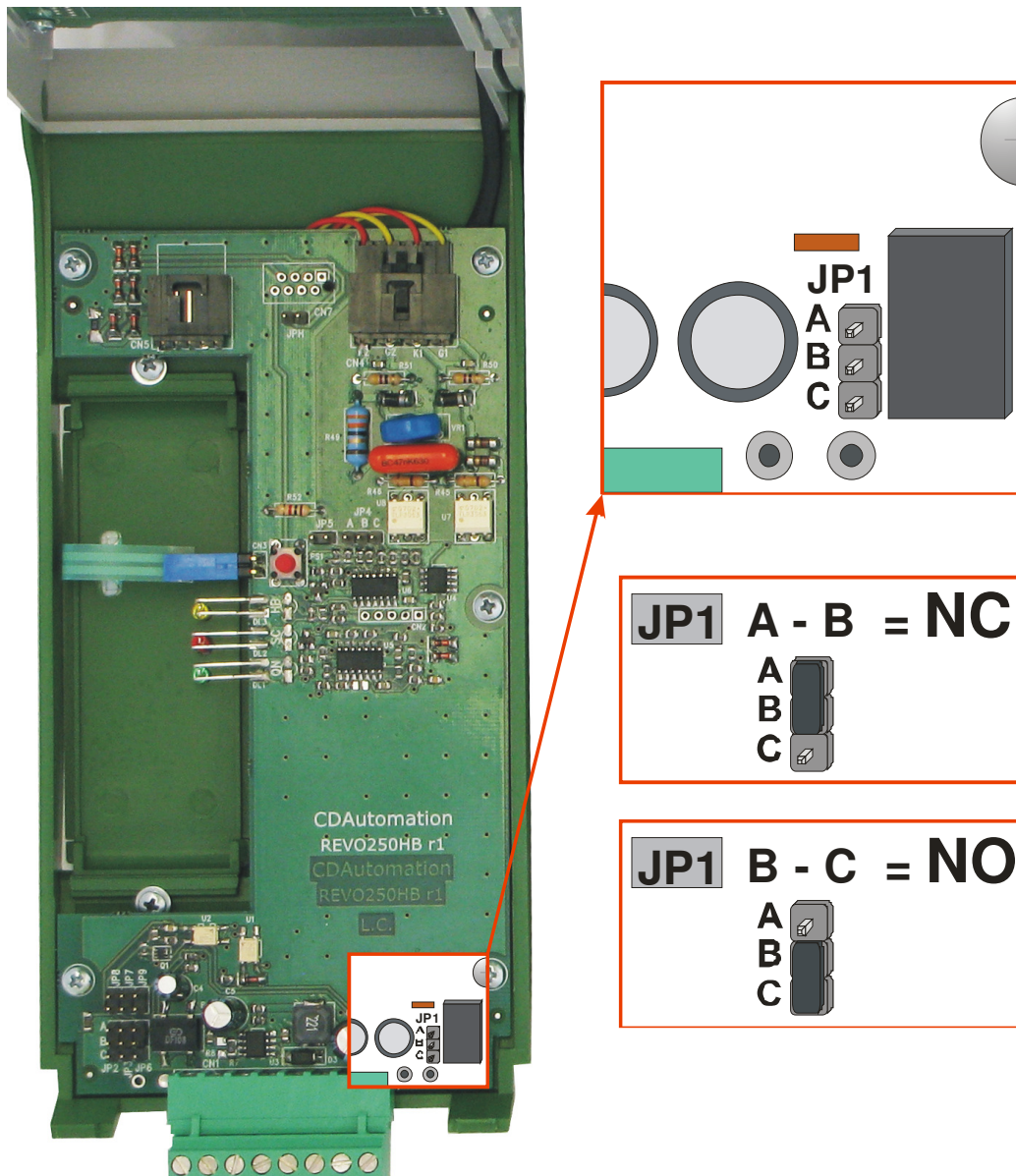

9 Input setting

The input type is already configured in line with customer requirements that are defined in the Order Code. However, if you wish to change the input type (ex. from 0÷10V to 4÷20mA) set the jumpers as below represented and then do the "Input calibration procedure":

Important: The analog input isn't isolated from Aux Supply. The series connection between analogue inputs of the units is not possible. With AC Aux supply it's not possible connect the zero terminal of Analogue Input to the earth. With DC Aux supply is not possible to connect the zero of the power supply with the zero of analog input.



Warning: Before operate, be sure that power and control cables are isolated from voltage sources

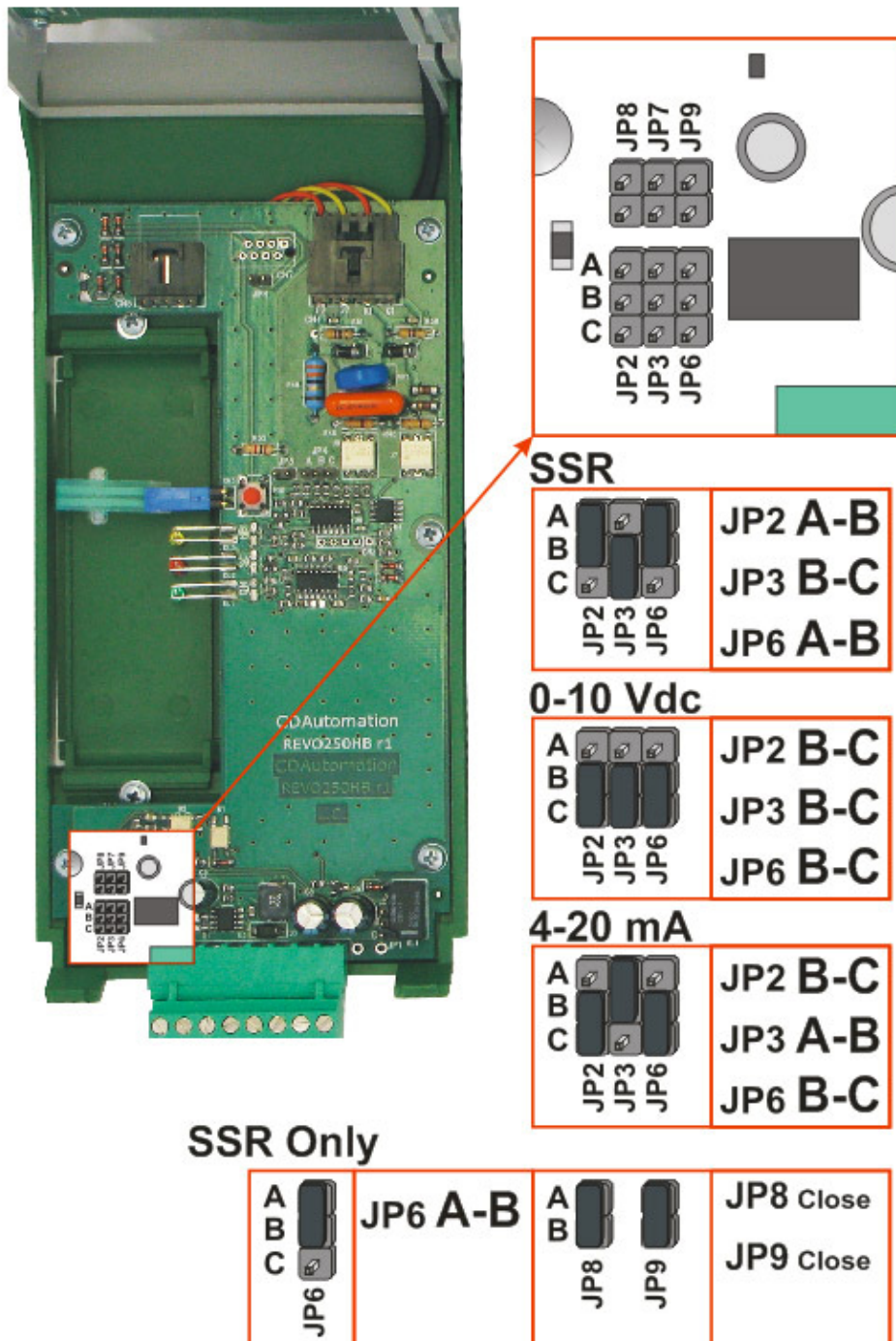

9.1 Input calibration procedure



Warning: this procedure can be done just by specialized personnel

This procedure is needed only if you change the input type

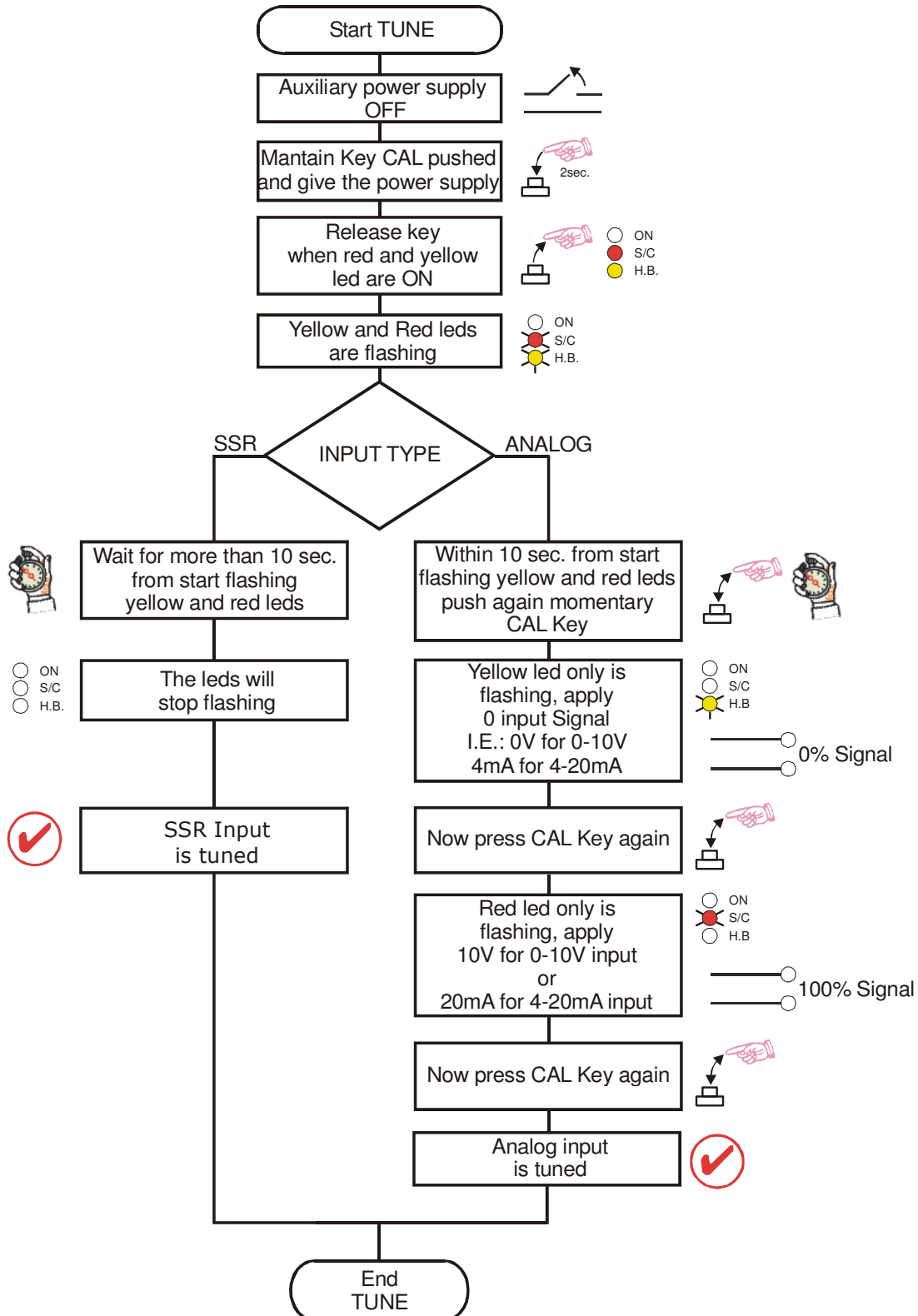

10 Firing type

Choose a correct firing type allows to optimize the thyristor unit for the installed load. The firing type has already configured in line with customer requirements, Zero Crossing for SSR input and Burst firing for Analog Input.



Caution: this procedure must be performed only by qualified persons.

10.1 Zero Crossing (ZC) with SSR input

ZC firing mode is used with Logic Output from temperature controllers and the Thyristor operates like a contactor.

The Cycle time is performed by temperature controller. ZC minimizes interferences because the Thyristor unit switches ON-OFF at zero voltage.

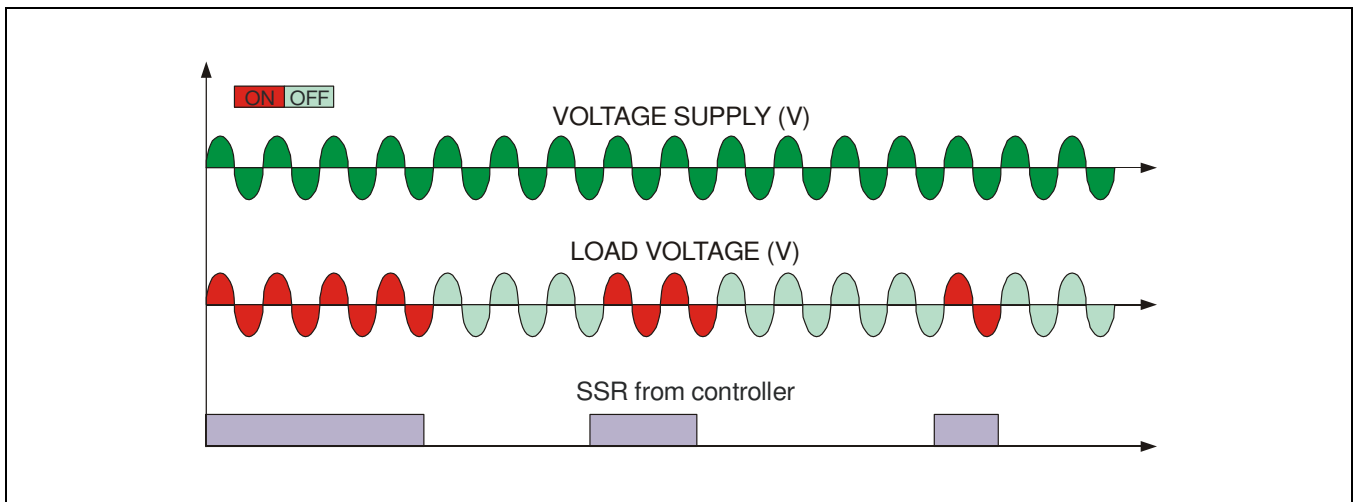

10.2 Burst Firing (BF) with Analog Input

The Burst Firing is similar to the Single Cycle, but consecutive cycles ON are selectable between 2 and 255, with input signal equal at 50%.

Burst Firing is a method zero crossing that it reduces the electromagnetic interferences because the thyristor switches at zero voltage crossing.

The example show the Burst Firing with Burst cycles: 4

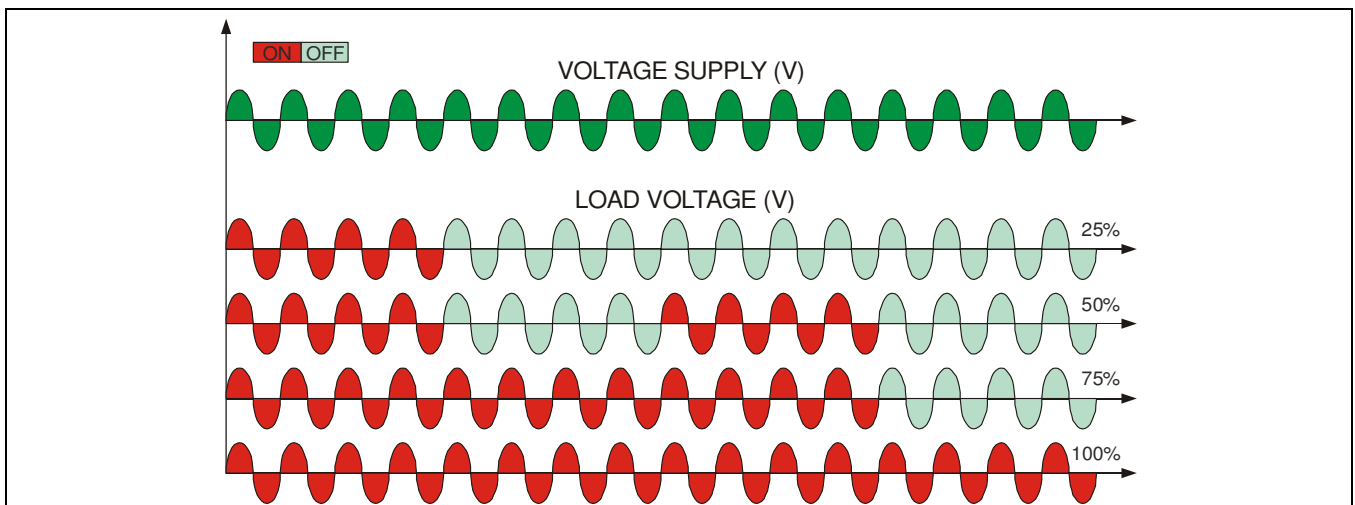

10.3 Burst Firing settings

The Burst Firing cycles is already configured in line with customer requirements that are defined in the Order Code. However, if you wish to change the Burst Firing cycles (es. from 4 to 8) set the jumpers as below represented:



Warning: Before operate, be sure that power and control cables are isolated from voltage sources

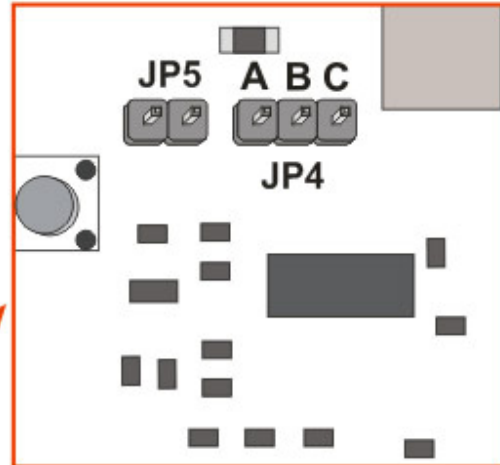
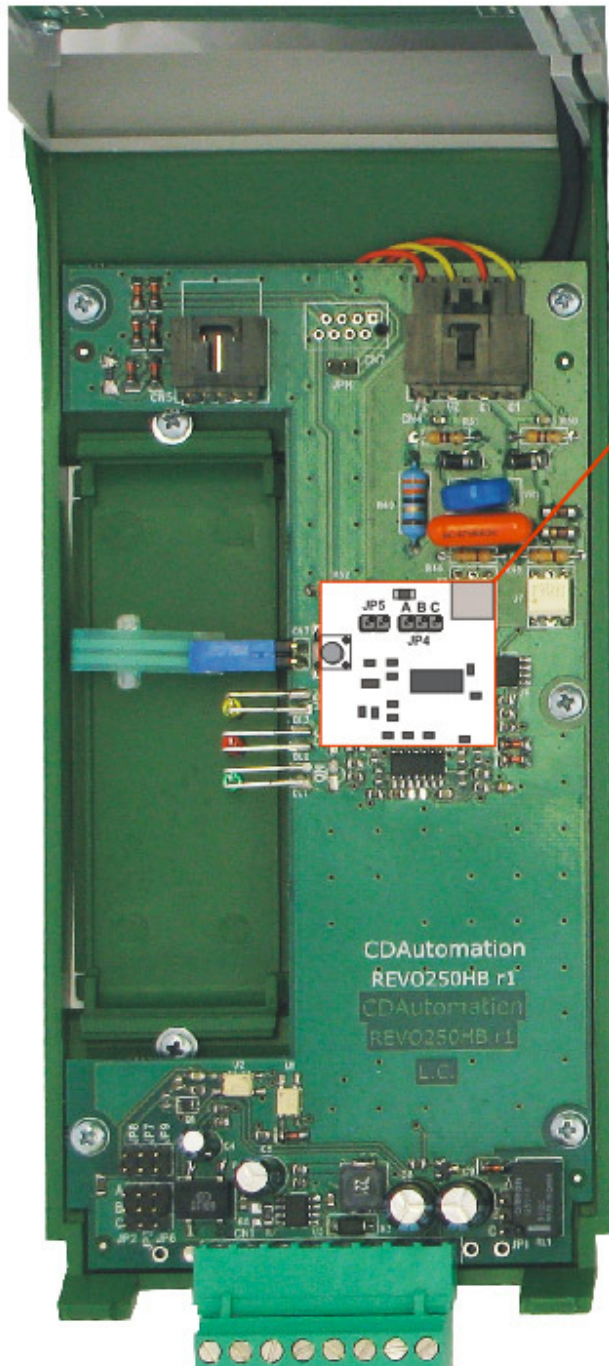

JP4

A	B	C	
			BF4 OPEN
			BF8 A-B
			BF16 B-C

11 Internal Fuse

The thyristor unit have internal fuse extrarapid at low I^2t for the thyristor protection of against the short-circuits. The Fuses must have I^2t 20% less than thyristor's I^2t . The warranty of thyristor is null if no proper fuses are used.

11.1 Internal Fuse

Type	Fuse Code Spare Part	Current (ARMS)	I^2T (A ² sec.)	Vac
060	100FE	100	2800	660
090	100FE	100	2800	660
120	FEE200	200	11400	660
150	FEE200	200	11400	660
180	URB315	315	82000	660
210	URB315	315	82000	660



Caution: High speed fuses are used only for the thyristor protection and can not be used to protect the installation.



Caution: The warranty of thyristor is null if no proper fuses are used. See tab.



Warning: When it is supply, the Thyristor unit is subject to dangerous voltage, don't open the Fuse-holder module and don't touch the electric equipments.

11.2 Fuses Replacement

Open the cover and remove the screws

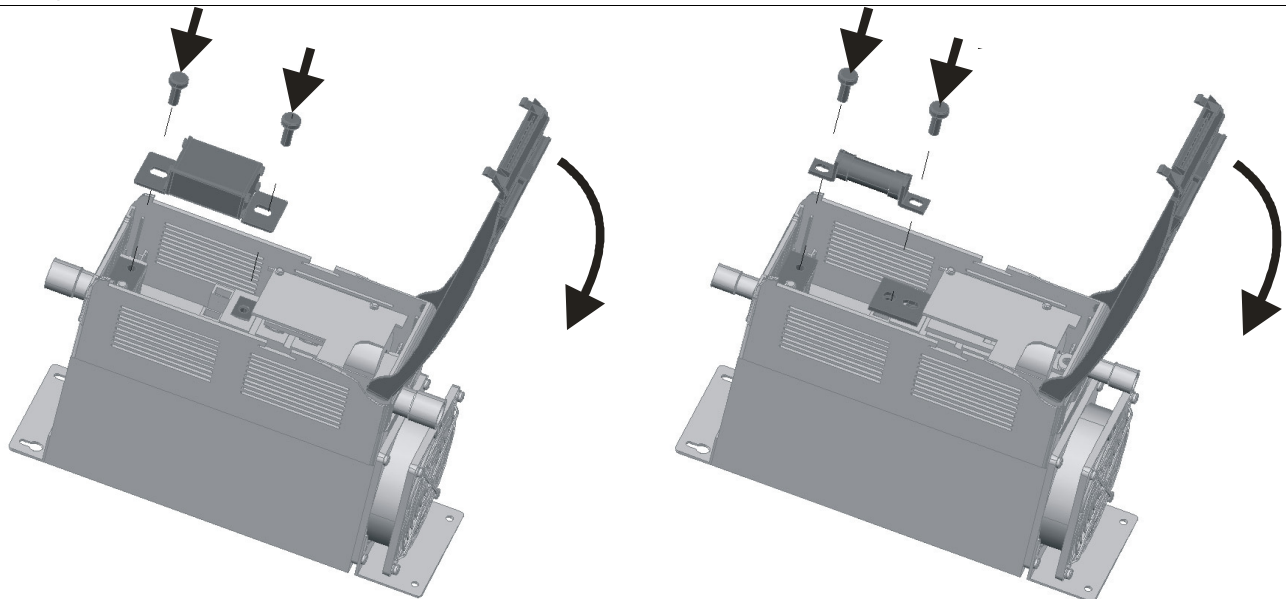

12 Maintenance

In order to have a corrected cooling, the user must clean the heat-sink and the protective grill of the fans. The frequency of this servicing depends on environmental pollution.

Also check periodically if the screw for the power cables and safety earth are tightened correctly (See Connection Diagram)

12.1 Trouble Shooting

Small problems sometimes can be solved locally with the help of the below tab of trouble shooting. If you don't succeed, contact us or your nearest distributor.

Symptom	Indication on front unit	Possible reasons of the symptom	Actions
Load current doesn't flow	Green LED (ON) light OFF	<ul style="list-style-type: none"> No Auxiliary Voltage No input signal Reversed polarities of input signal 	<ul style="list-style-type: none"> Give auxiliary voltage supply (See Connection Diagram) Provide to give input signal Reverse the input signal polarity
	Green LED (ON) light ON	<ul style="list-style-type: none"> Fuse failure Load connection interruption Load failure: The yellow led (HB) is light on (with HB option) Thyristor fault: The red led (SC) is light on (with HB option) 	<ul style="list-style-type: none"> Change the fuse Check the wiring Check the load Change the thyristor module
Load current flow also without input signal	Red LED (SC) light on	<ul style="list-style-type: none"> Wrong wiring SCR short circuit 	<ul style="list-style-type: none"> Check the wiring Change the thyristor module
Current flows at nominal value but Yellow LED (HB/SC) is light on	Yellow LED (HB) light on or Red LED (SC) light on	<ul style="list-style-type: none"> HB circuit not tuned Current transformers not properly wired 	<ul style="list-style-type: none"> Make HB calibration procedure Check current transformers wiring
Thyristor unit doesn't work properly		<ul style="list-style-type: none"> Auxiliary voltage supply out of limits Wrong input signal selection. Wrong input signal calibration (out of range) 	<ul style="list-style-type: none"> Verify the auxiliary voltage supply Control input signal setting. Check input setting

12.2 Warranty condition

CD Automation gives a 12 months warranty to its products.

The warranty is limited to repairing and parts substitution in our factory and does exclude products not properly used and fuses.

Warranty does not include products with serial numbers deleted. The faulty product should be shipped to CD Automation at customer's cost and our Service will evaluate if product is under warranty terms.

Substituted parts remain of CD Automation property.



