

Rx (ERV) Series



Commercial Rooftop Energy Recovery Ventilator

Installation, Operation & Maintenance Instructions

97B0042N01

Revision: 09/09/08B



Table of Contents

Model Nomenclature	3-4
General Information	5
Sequence of Operation Overview	6
ERV Sequence of Operation - Sheet A	7
ERV Sequence of Operation - Sheet B	8
ERV Sequence of Operation - Sheet C	9
Roofcurbs for Mated Applications	10
Installing Hoods to ERV Unit	11
Setup & Adjustments	12
ERV Start-Up	13
Maintenance	13
AirXchange Wheel Service	15
ERV Replacement Parts - "A" Cabinet	21
ERV Replacement Parts - "B" Cabinet	22
ERV Replacement Parts - "C" Cabinet	23
ERV Replacement Parts - "D" Cabinet	24
ERV Additional Replacement Parts	25
Revision History	26

Model Nomenclature

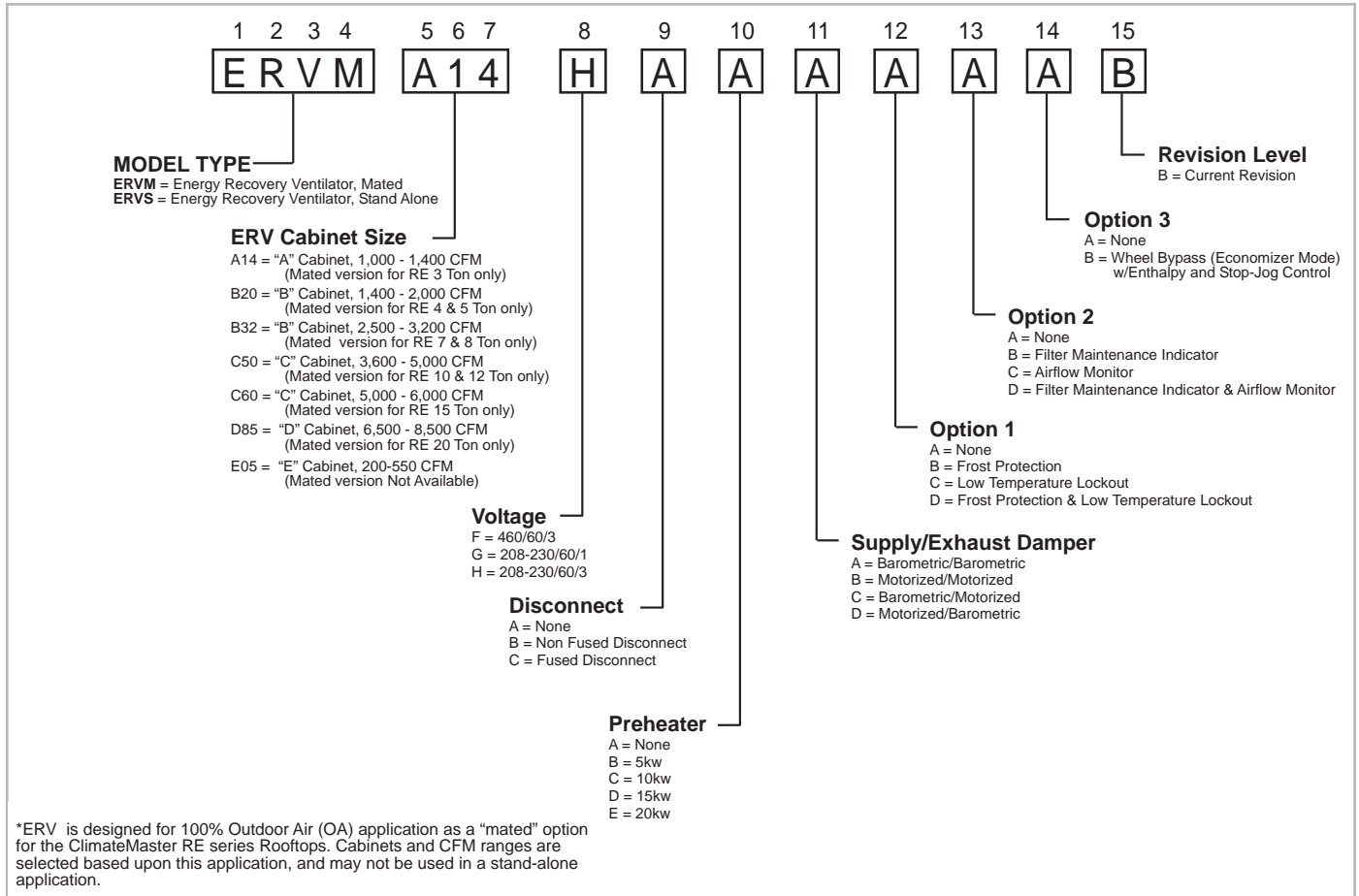

Rx (ERV) Module

Rev.: 09/09/08B

Model Nomenclature

Roof Curb

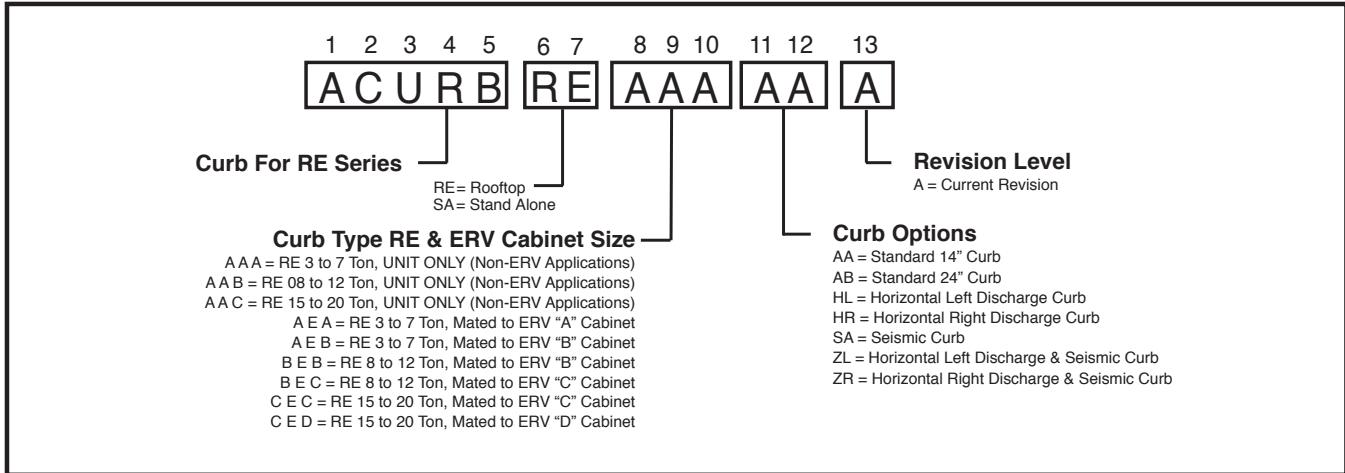

Transition

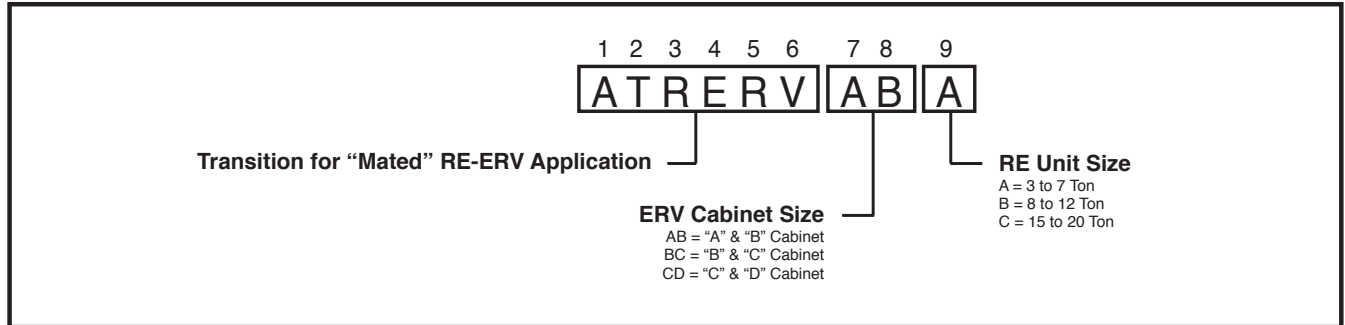

Rev.: 10/04/05D

Pre-Heater

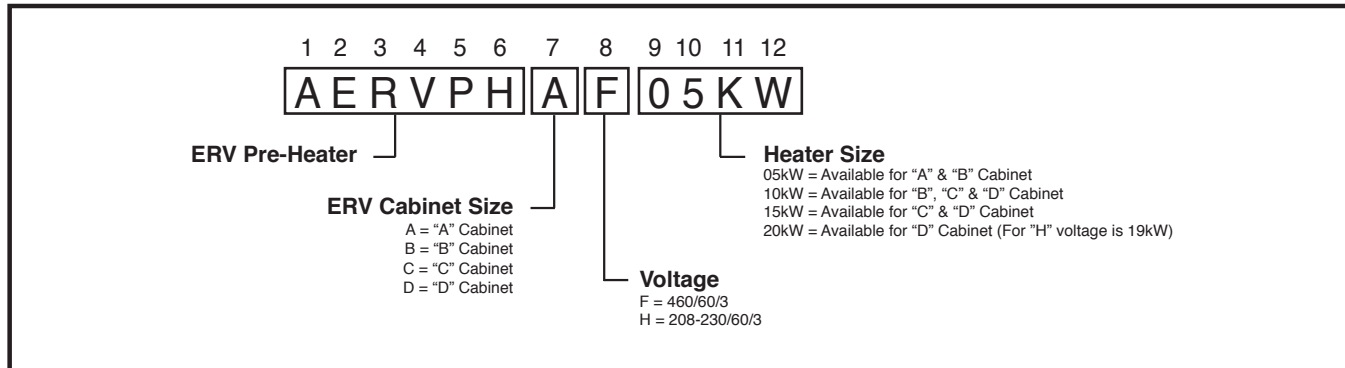

Rev.: 10/04/05D

General Information**Inspection**

Upon receipt of the equipment, carefully check the shipment against the bill of lading. Make sure all units have been received. Inspect the packaging of each unit, and inspect each unit for damage. Assure the carrier makes proper notation of any shortages or damage on all copies of the freight bill and completes a common carrier inspection report. Concealed damage not discovered during unloading must be reported to the carrier within 15 days of receipt of shipment. If not filed within 15 days, the freight company can deny the claim without recourse.

Note: It is the responsibility of the purchaser to file all necessary claims with the carrier. Notify the ClimateMaster Traffic Department of all damage within fifteen (15) days of shipment.

Storage

Equipment should be stored in its packaging in a clean, dry area. Store units in an upright position at all times. Do not stack units.

Unit Protection

Cover units on the job site with either shipping packaging or an equivalent protective covering. In areas where painting, plastering, and/or spraying has not been completed, all due precautions must be taken to avoid physical damage to the units and contamination by foreign material. Physical damage and contamination may prevent proper start-up and may result in costly equipment clean-up.

Examine all transitions, curbs, hoods, and options before installing any of the system components. Remove any dirt or trash found in or on these components.

Pre-Installation

Installation, Operation, and Maintenance instructions are provided with each unit. ERV equipment is designed for installation in conjunction with the RE Series Rooftop units. The installation site chosen should include adequate service clearance around the unit. Before unit start-up, read all manuals and become familiar with the unit and its operation. Thoroughly check the system before operation.

Prepare units for installation as follows:

1. Compare the electrical data on the unit nameplate with ordering and shipping information to verify that the correct unit has been shipped.
2. Keep the cabinet covered with the shipping packaging until installation is complete.
3. Inspect all electrical connections. Connections must be clean and tight at the terminals.
4. Remove any blower support packaging.

Use caution when installing or servicing the ERV unit. High voltage power and moving parts (blowers, motors, wheel) are housed within the ERV cabinet.

Follow all local electrical codes and ordinances.

⚠ WARNING! ⚠

This unit contains high voltage power. Disconnect power before servicing.

⚠ WARNING! ⚠

This unit contains high voltage power. Only qualified technicians should install or service this equipment.

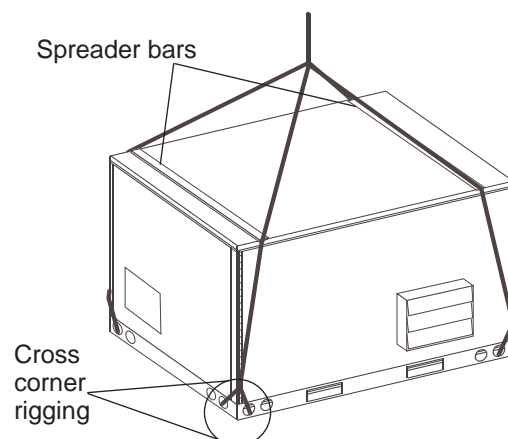
Rigging for ERV Installation

1. Never lift ERV unit with panels or doors open or off.

Rx (ERV) Module
Rev.: 09/09/08B

Sequence of Operation Overview

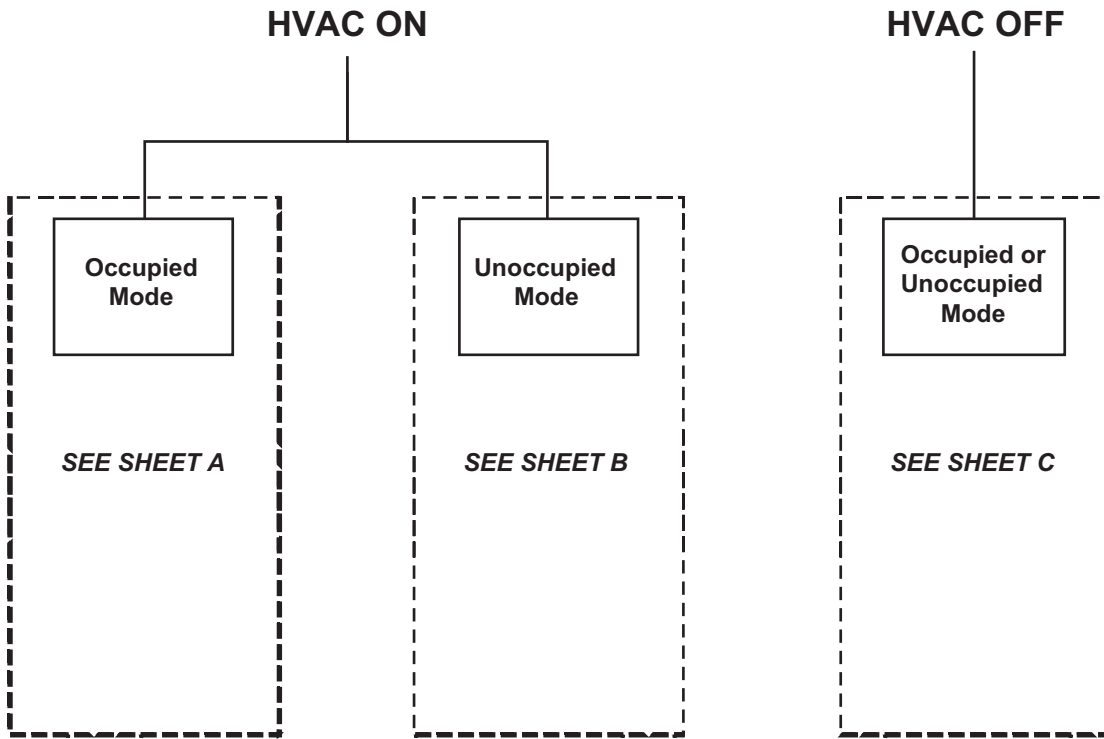

ERV Sequence of Operation - Sheet A

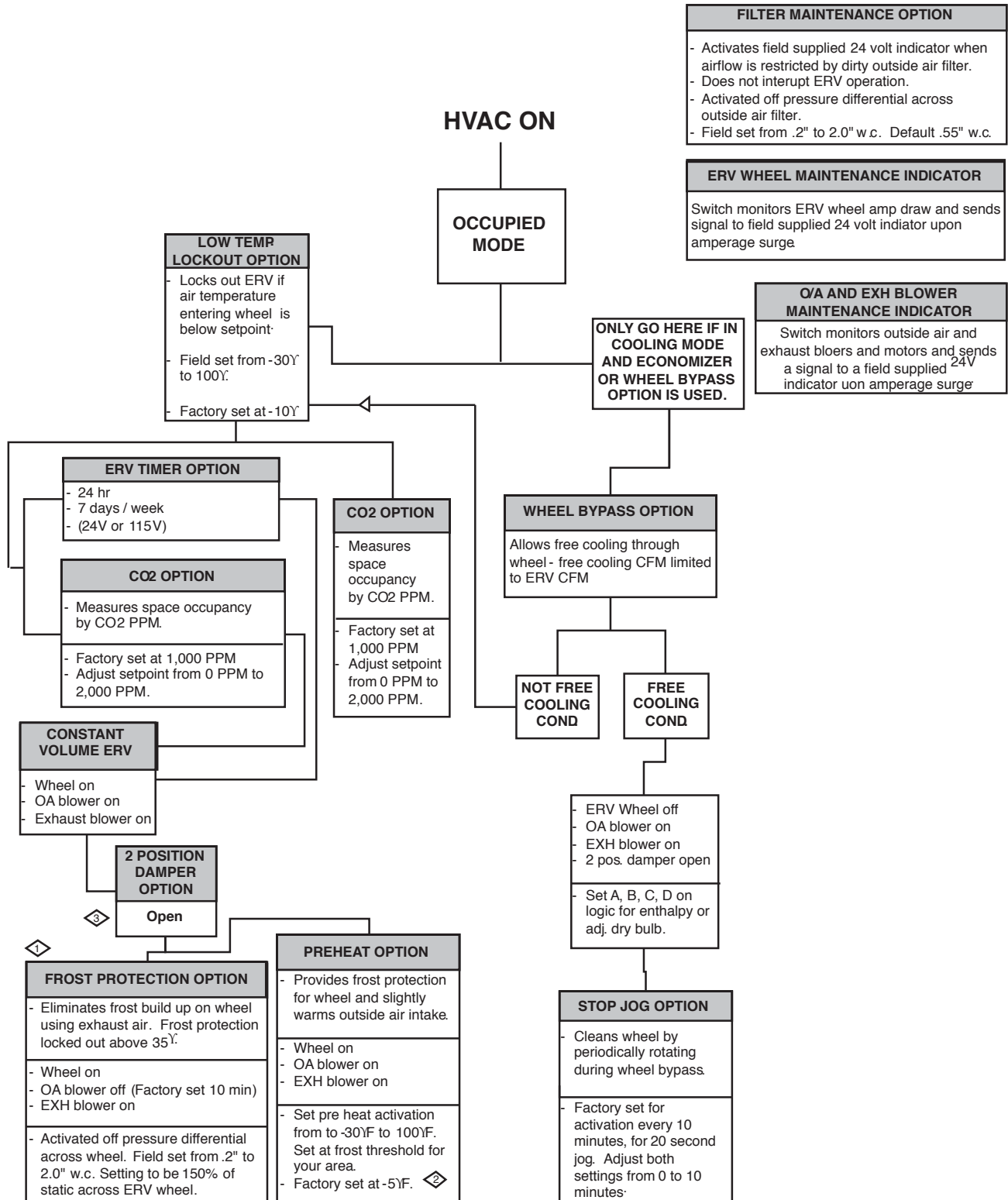

① If outside air temperature is under 35°F and is not properly maintained, a dirty wheel could activate the frost control option.

② Preheat option may also use a pressure differential switch to determine if there is a frost build up on ERV wheel.

③ 2 position damper option will slightly delay activation of ERV blowers.

ERV Sequence of Operation - Sheet B

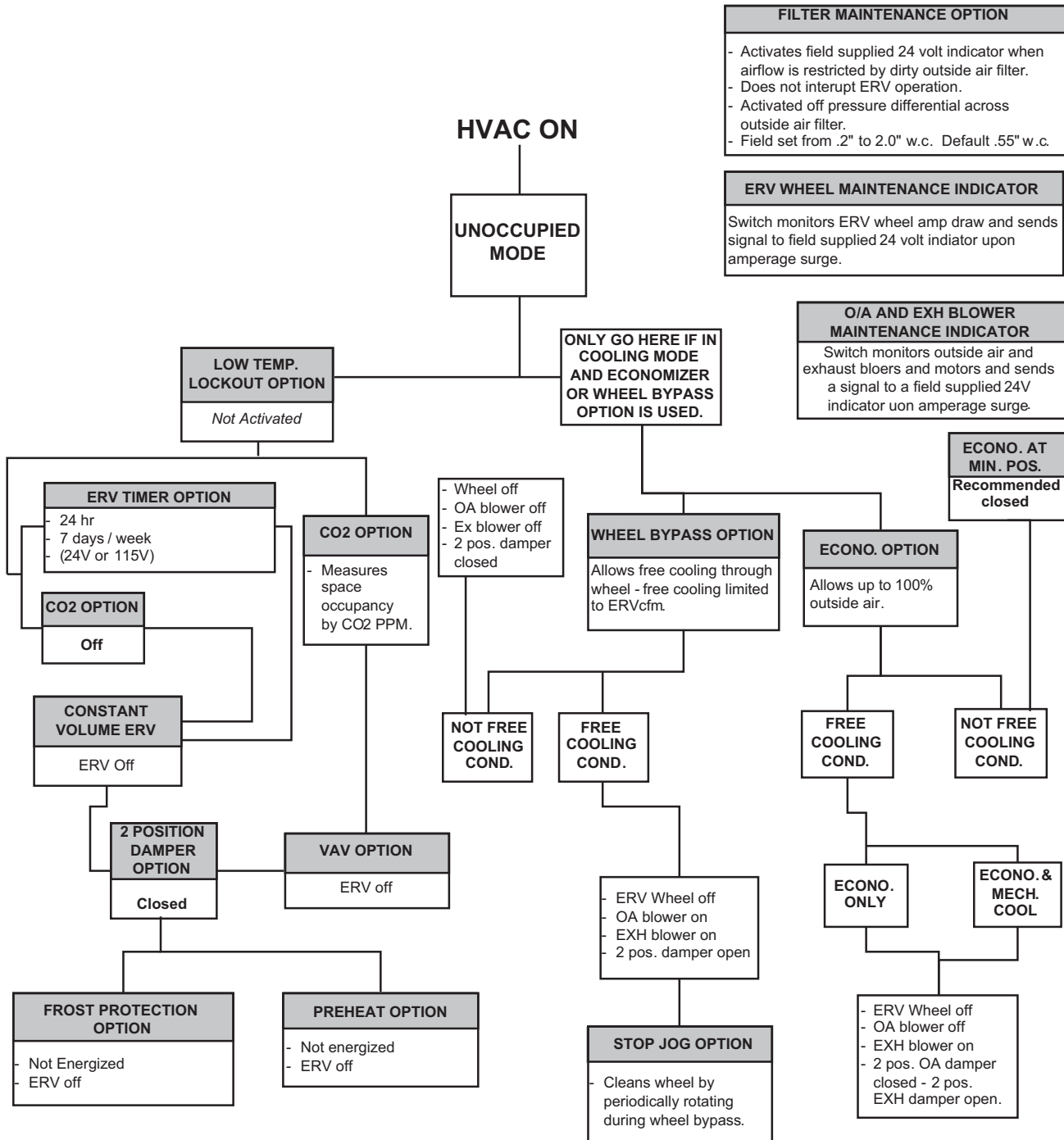

ERV Sequence of Operation - Sheet C

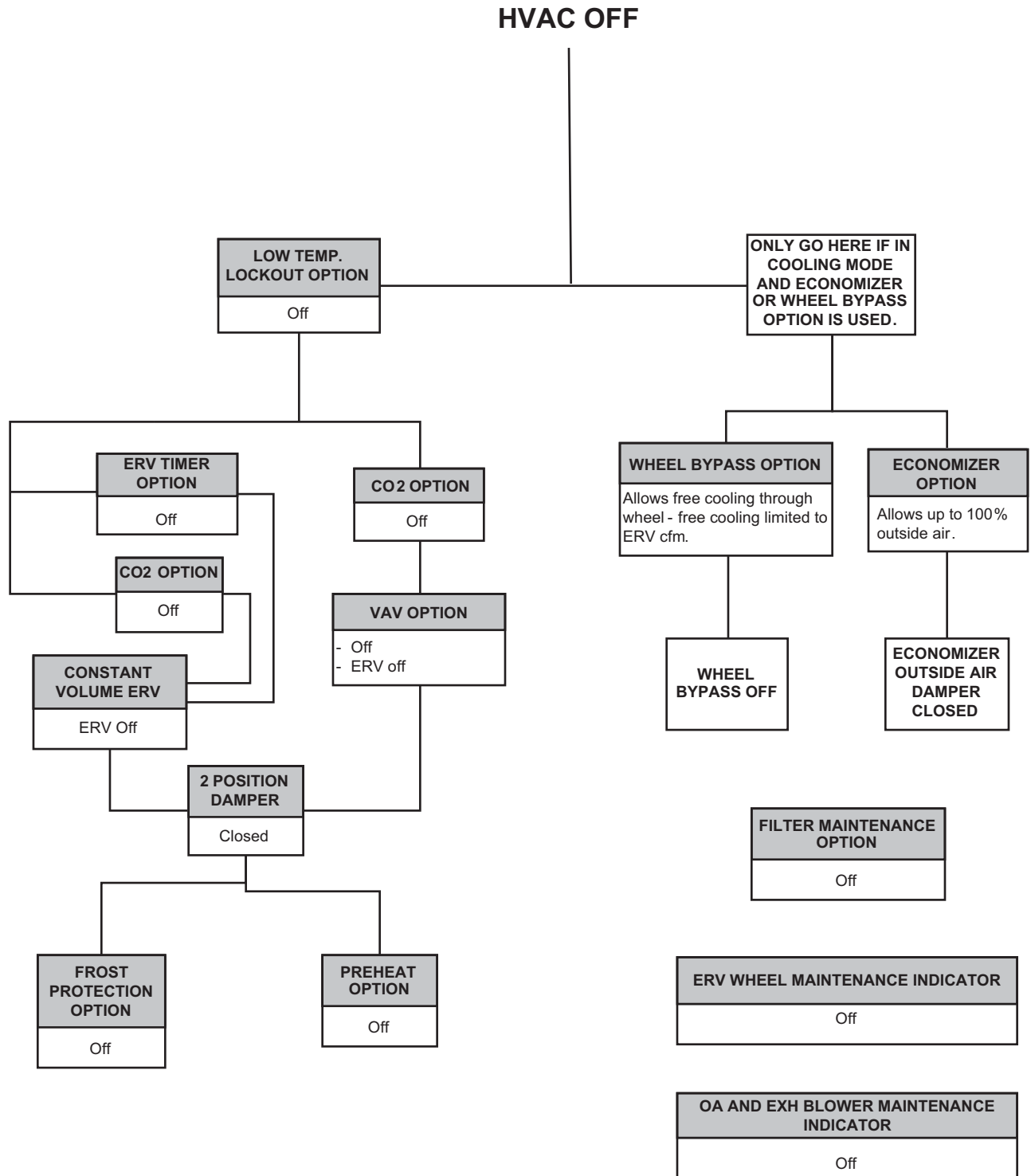

Rx (ERV) Module

Rev.: 09/09/08B

Roofcurbs For Mated Applications

1. Remove curb from package.
2. Bring together one end and one side of the curb.
3. Insert tabs on curb ends into slots on curb side. Press together until tabs lock in place. It may be necessary to firmly step on top of curb to lock tab in place. Repeat for all four corners.
4. Set duct supports and decks in place (Figure 1).

NOTE: Insulation on deck faces upward.

5. If lifting curb after it has been assembled, hammer all corner tabs over to side.
6. Level curb.
7. Insulate and add cant strip to the curb. Follow the suggested roofing procedures or acceptable procedures for applying roofing. The roofing should extend up to the tack strip and be secured under proper counter flashing (Figure 3).
8. Gasket perimeter of curb with provided gasketing.

Figure 1: Curb Isometric View

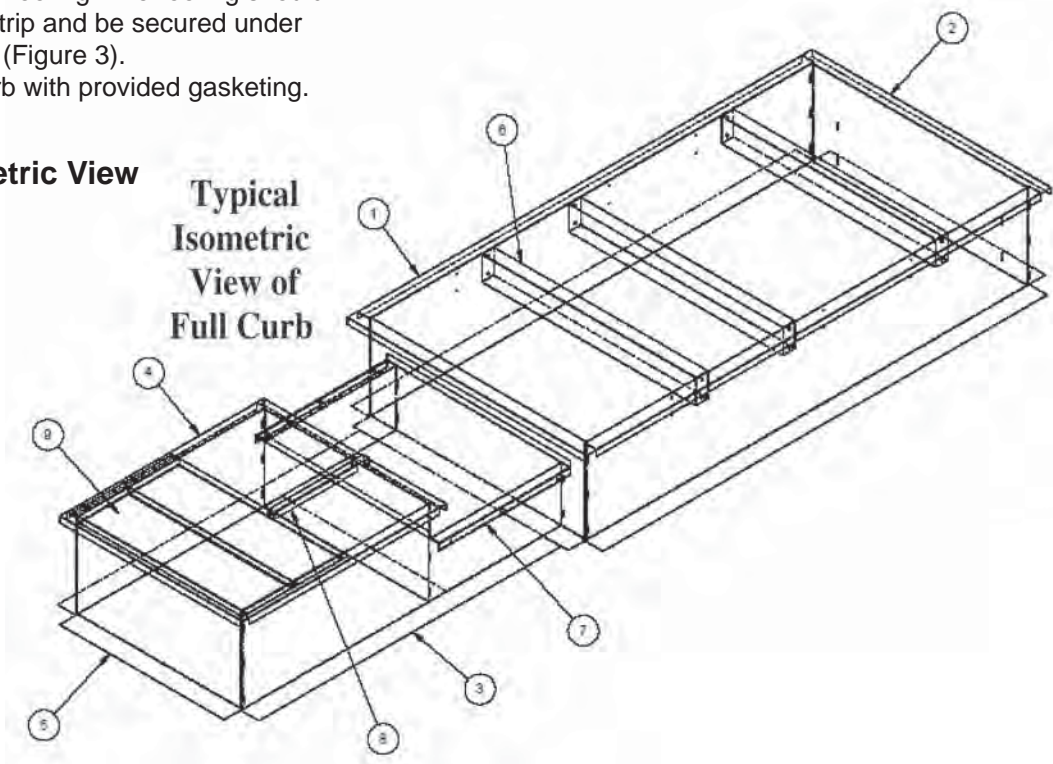

Figure 2: Curb Detail

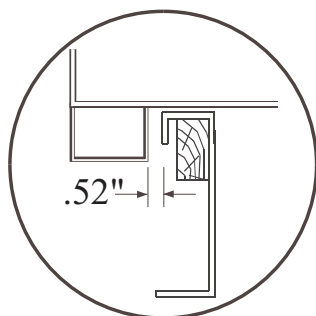
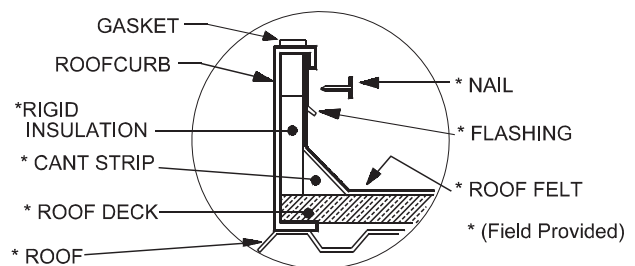

Figure 3: Roofing Detail



Installing Hoods To ERV Unit

1. Locate outside air hood and relief hood, shipped inside ERV unit. Assemble per dimensions shown. Outside air hood: The outside air hood includes an aluminum water entrainment filters and optional pre-heater.

Note: Some hoods are factory assembled and installed.

2. Gasket flange of hoods and screw hoods to ERV unit as shown.
3. Factory provides a knock-out for power supply hook-up. Installing contractor must insure that cabinet is watertight after disconnect has been installed (Factory installed disconnect optional).

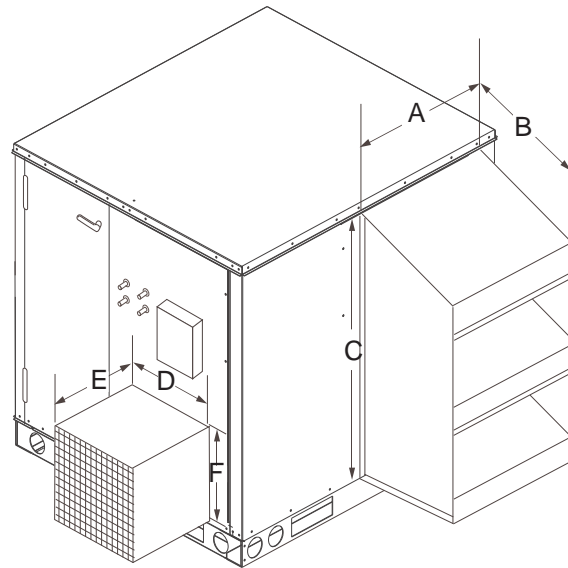

Cabinet	Outside Air Hood			Relief Hood			Outside Air Aluminum Filter
	A	B	C	D	E	F	
A	17"	19"	31.75"	10.5"	11"	11"	(3) 12" X 12"
B	26.4"	24.5"	43.3"	16.2"	16"	15.9"	(3) 11" X 19.5"
C	28.6"	27.75"	59.5"	19.7"	20"	16.5"	(4) 20" X 22.5"
D	38.5"	35.15"	71.5"	23.1"	24"	21.5"	(5) 25" X 33"

Installing Transition to ERV Unit

1. Caulk mating flanges on both sides of transition and install between HVAC unit and ERV unit. Screw in place.
2. A Molex type connector is provided to connect the ERV to the RE Series rooftop unit when the RE is ordered with the ERV option. All wiring for basic operation and options are pre-installed in the Molex connectors. Connect the two wiring harnesses and insure that the wiring is routed to avoid any sharp edges or placement where the wires could be pinched.
3. Screw transition to HVAC unit. Seal watertight.

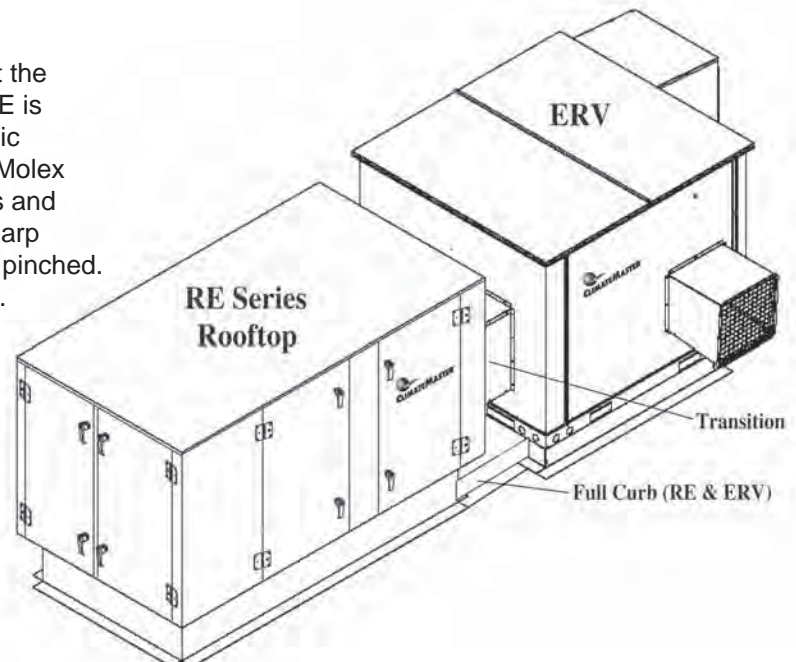

Rx (ERV) Module

Rev.: 09/09/08B

Setup & Adjustments

⚠ WARNING! ⚠

This unit contains high voltage power. Disconnect power before servicing.

⚠ CAUTION! ⚠

All access doors have a microswitch which interrupts power when doors are open.

⚠ WARNING! ⚠

This unit contains high voltage power. Only qualified technicians should install or service. Follow all local electrical codes and ordinances.

1. The ERV unit must have its own disconnect.
2. Check for appropriate wiring diagrams.
3. Before providing power to the ERV unit be sure all access doors are shut tight. Door interlock switches will interrupt power if doors are open.
4. Power unit and inspect both blowers and ERV wheel to ensure operation.
5. **Important:**
For highest effectiveness the inlet and exhaust flow should be equal across both sides of the ERV wheel. Setting the appropriate blower speed requires that the installer determine the application's actual ventilation rate and external static pressure. Adjust blowers to obtain the required CFM.
6. ClimateMaster has installed an air monitoring station in order to determine the supply and exhaust airflow. In order to use this station, the installer needs to connect a slope gage or magnehelic gage to the airflow station. Both the low and high pressure fittings must be used due to the fact that the airflow quantity is calibrated against the pressure drop across the wheel.

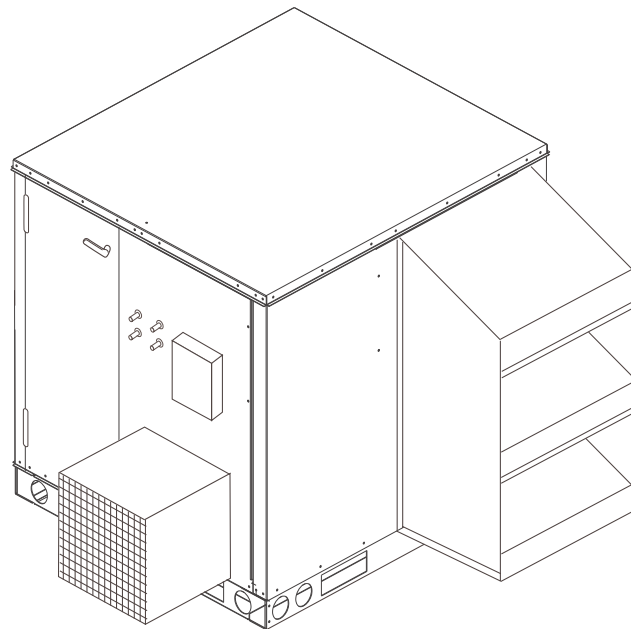

ERV Start-up Check List

1. BEFORE power is connected to the unit, check that the Airxchange wheel can be rotated by hand. This insures that the wheel is free of any obstructions hindering its rotation and that the wheel is properly mounted on its hub.
2. Insure that all wires are connected and doors are shut.
3. After applying power, check that the wheel is rotating. This can be done by turning the unit on, opening the door on the supply side and pushing the interlock safety switch in. Check that the blowers are rotating in the correct direction.
4. If any options are installed, check operation per the installation manual and wiring diagrams.
5. Insure that when the rooftop unit is energized that the ERV unit is operating. If the wheel bypass option is installed, the wheel may not be rotating when "economizer mode" is required.
6. Follow start-up check list for the rooftop unit in the Installation Operating and Maintenance instructions.

Maintenance & Service**▲ WARNING! ▲**

1. **Before performing service or maintenance operations on unit, turn off main power switch to unit. Electrical shock could cause personal injury.**
2. **Do not operate the ERV without the filters installed. These filters prevent the entry of foreign objects such as leaves, birds, etc..**

1. **Fresh Air Filters:** There are 1" metal mesh outside air filters located inside the fresh air intake hood. Periodically filters must be inspected for dirt/dust buildup which could adversely affect performance if allowed to restrict air flow. When a filter requires cleaning, it is removed by pulling down the (2) retaining clips, then grasping the filter, and pulling the filter down and then forward. Clean the filter by rinsing in warm water and a mild detergent. Pleated media filters are factory installed in the fresh air intake compartment for additional filtration. Access is provided through a hinged access door. A 2" filter track is provided in front of the ERV wheel to filter the air.
2. **Energy Recovery Wheel Segments:** When the ERV is used to ventilate an occupied space, annual inspection of the self-cleaning wheel is recommended as a minimum. However, when unusually high levels of indoor contaminants exist, as in smoking applications, more frequent inspections are recommended to determine appropriate cleaning cycles. To inspect the wheel, disconnect power to the unit. Open hinged access doors, unplug wheel drive motor, and pull the cassette halfway out to first stop. Each segment is secured in place by a spring steel

retainer located on the wheel rim. Remove one end of the steel retainer from the slot in the wheel rim and remove. Continue to next retainer, Remove segment and continue sequence. Clean the segment by rinsing in warm water and a mild detergent. DO NOT STEAM CLEAN, KEEP WATER TEMPERATURE UNDER 140°. Segments may be installed by reversing the procedure.

Upon completion, turn wheel clockwise by hand to verify free operation, recheck security of each segment and determine air seals around outside of rotary wheel and across the center (both sides of wheel) are secure and in good condition. Slide cassette into the unit, plug in and secure motor lead to the electrical receptacle, and closed hinged door. Start unit and verify proper operation.

▲ CAUTION! ▲

CAUTION! Do not restart units without inspection and remedy of faulting condition. Equipment damage may occur.

Rx (ERV) Module

Rev.: 09/09/08B

ERV Maintenance Check List**Visual observation of the ERV exterior – Check the following:**

- Make sure there are no dents, holes, loose screws, broken hoods, etc. Make a general inspection of the condition of the exterior.
- Make sure all doors are tightly secured.
- Make sure all dampers are free to move.
- Make sure all hoods, if applicable, are not damaged.
- Make sure that the water entrainment filter is clean.
- Make sure that the ERV/RTU transition is secure.

Visual observation of the ERV interior - Check the following:

- Check that the wheel can move freely. Spin by hand to insure that nothing is impeding the wheel's movement.
- Check that the wheel is receiving power. With the door open, push in on the safety switch and insure that the wheel rotates. The wheels rotate between 40 and 60 rpm.
- Check the wheel for dirt. If the wheel or segments of the wheel are dirty, Clean them using a non-acid based coil cleaner or alkaline detergent solution.
- Check the filters. If dirty, replace.
- Check the blowers. Insure that the blowers are rotating in the right direction. Check that the seals around the doors are not cut, damaged or have holes in them that would allow water to penetrate into the cabinet.
- Check belts for wear and tension. Belts can be compressed about one-half inch.
- Check alignment of the pulleys.
- Check that the bushings in the blowers are in place.
- Check that the cabinet interior is dry.

⚠ CAUTION! ⚠

Do not steam clean the ERV wheel segments or subject them to temperatures above 170°F. High temperatures or steam will damage the heat exchange surface. Soak the wheel segments in 140°F or cooler water temperature for cleaning.

AirXchange Wheel Service

AIRXCHANGE™
85 Longwater Drive
Rockland, MA 02370

SERVICE INSTRUCTION

NO. SI000044C

DATE: 6/04/03

PAGE 1 OF 2

ENERGY TRANSFER SEGMENT INSTALLATION

FOR MODELS ERC-36" through 81"

GENERAL

Energy Transfer Segments are the "heat exchangers" of the cassette. These are not filters and represent a substantial portion of the value of the cassette. Segments must be handled with care and never be dropped. Use a suitable crate or harness to lift segments to a roof surface, never use the shipping cartons for this purpose. Segments may require "slight" persuasion during installation and removal but never be forced or banged with a hammer or similar tool.

TOOLS REQUIRED: "STOP" for stabilizing wheel (see CAUTION)

WARNING
BEFORE PERFORMING SERVICE OR MAINTENANCE OPERATIONS ON UNIT, TURN OFF MAIN POWER SWITCH TO UNIT. ELECTRICAL SHOCK COULD CAUSE PERSONAL INJURY

NOTE
BOTH INSTALLATION AND REMOVAL PROCEDURES MUST BE PERFORMED FROM THE PULLEY SIDE OF THE CASSETTE

CAUTION
CAUTION! Weight of the installed segment will cause the wheel to accelerate in rotation. Failure to maintain control of the wheel rotation while installing all segments could cause severe injury to fingers or hand caught between revolving spokes and the bearing support beam. Handle of hammer, or other stop, should be inserted through spokes and above or below bearing support beams to limit rotation of unbalanced wheel. See Figure 1.

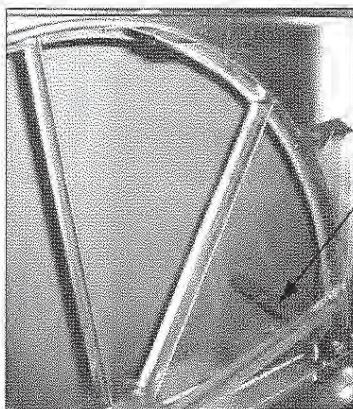

Hammer used as "stop"

Figure 1



Figure 2

INSTALLATION PROCEDURE

1. Begin by positioning one segment opening at the top of the cassette. Unlock and open the segment retaining brackets on both sides of the selected segment opening. See Figure 1.
2. Holding the segment as vertically as possible and centered between spokes, insert nose of segment downward between the hub plates. See Figure 2.

Rx (ERV) Module

Rev.: 09/09/08B

NO. SI0000044C

DATE: 6/04/03

PAGE 2 OF 2

NOTE

The face of the segment, with the imbedded stiffener (vertical support between nose and rim end of segment) must face the motor side of the cassette. See Figure 3.

Figure 3.
View from
motor side
of segment

Imbedded Stiffeners



3. Ease the segment downward until its outer rim clears the inside of the wheel rim. Then press the segment inward against the spoke flanges.
4. Close and latch segment retaining brackets to the position shown in Figure 4. Make certain the retaining bracket is fully engaged under the catch.
5. Slowly rotate, by hand, the first installed segment to the bottom of the cassette, then install the second segment opposite the first. Repeat this sequence with the two installed segments rotated to the horizontal position to balance the weight of installed segments. Continue this sequence with the remaining segments.

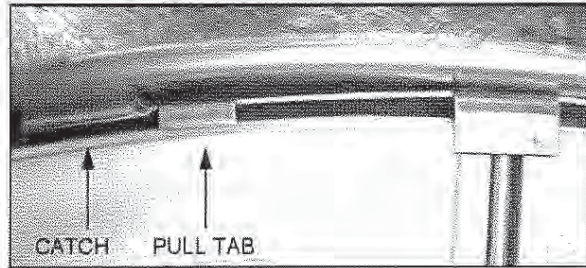

Figure 4

REMOVAL PROCEDURE

1. Unlock and open the segment retaining brackets on both sides of the selected segment opening. Refer to Figure 5.
2. Gently lift segment outward.
3. Close segment retaining latches and rotate wheel 180° to remove next segment. Follow this pattern to remove all segments. This pattern will help keep wheel balanced.



Figure 5

ROUTINE MAINTENANCE

Routine maintenance of the Energy Recovery Cassettes includes periodic cleaning of the Energy Recovery Wheel as well as inspection of the Air Seals and Wheel Drive Components as follows:

Cleaning

The need for periodic cleaning of the energy recovery wheel will be a function of operating schedule, climate and contaminants in the indoor air being exhausted and the outdoor air being supplied to the building.

The Airxchange wheel is "self-cleaning" with respect to dry particles due to its laminar flow characteristics. Smaller particles pass through; larger particles land on the surface and are blown clear as the flow direction is reversed. Any material that builds up on the face of the wheel can be removed with a brush or vacuum. The primary need for cleaning is to remove oil based aerosols that have condensed on energy transfer surfaces.

A characteristic of all dry desiccants, such films can close off micron sized pores at the surface of the desiccant material, reducing the efficiency by which the desiccant can adsorb and desorb moisture and also build up so as to reduce airflow.

In a reasonably clean indoor environment such as a school or office building, measurable reductions of airflow or loss of sensible (temperature) effectiveness may not occur for several years. Measurable changes in latent energy (water vapor) transfer can occur in shorter periods of time in applications such as moderate occupant smoking or cooking facilities. In applications experiencing unusually high levels of occupant smoking or oil based aerosols such as industrial applications involving the ventilation of machine shop areas for example, annual washing of energy transfer may be necessary to maintain latent transfer efficiency. Proper cleaning of the energy recovery wheel will restore latent effectiveness to near original performance.

To clean, gain access to the energy recovery wheel and remove wheel. Brush foreign material from the face of the wheel. Wash the wheel in a 5% solution of non-acid based coil cleaner (such as Acti-Klean, available through Grainger, Stock # 5W402) or alkaline detergent and warm water.

Soak in the solution until grease and tar deposits are loosened (Note: some staining of the desiccant may remain and is not harmful to performance). Before removing, rapidly run finger across surface of wheel to separate polymer strips for better cleaning action. Rinse dirty solution from wheel and remove excess water before reinstalling.

CAUTION

Do Not use acid based cleaners, aromatic solvents, steam or temperatures in excess of 170°F; damage to the wheel may occur !

Air Seals

Diameter seals are provided on each cassette to minimize transfer of air between the counter flowing airstreams.

To adjust diameter seals, loosen diameter seal adjusting screws and back seals away from wheel surface (Figure 2). Rotate wheel clockwise until two opposing spokes are hidden behind the bearing support beam. Using a folded piece of paper as a feeler gauge, position paper between the wheel surface and diameter seals. Adjust seals towards wheel surface until a slight friction on the feeler gauge (paper) is detected when gauge is moved along the length of the spoke. Retighten adjusting screws and recheck clearance with "feeler" gauge.

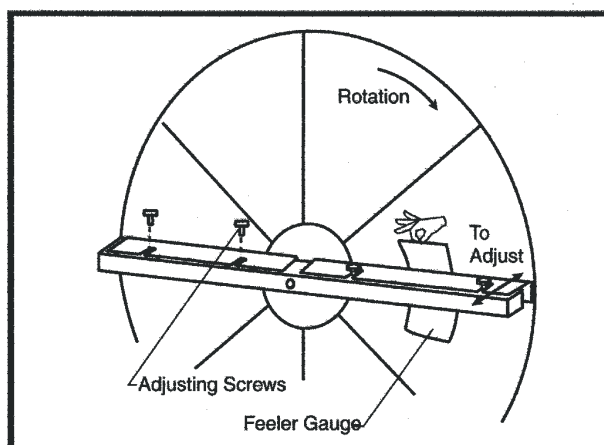

Figure 2 Diameter Seal Adjustment

Wheel Drive Components

The **wheel drive motor** bearings are pre-lubricated and no further lubrication is necessary. Make certain air cooling ports are not blocked.

The **wheel drive pulley** is secured to the drive motor shaft by a set screw. The set screw is secured with removable locktite to prevent loosening. Annually confirm set screw is secure.

The **wheel drive belt** is a urethane stretch belt designed to provide constant tension through the life of the belt. No adjustment is required. Inspect the drive belt annually for proper tracking and tension. A properly tensioned belt will turn the wheel immediately after power is applied with no visible slippage during start-up.

Rx (ERV) Module

Rev.: 09/09/08B

SERVICE**Energy Transfer Wheel Removal and Replacement****19" Through 21" Series**

Energy Transfer Wheels are secured to the shaft and bearing support beam by a Philips head screw and hub cover. See Figure 3.

To remove the Energy Transfer Wheel, follow steps one through four below. (See Fig. 3). Reverse procedure for wheel

1. Remove front seal assembly (pulley side of cassette) if present.
2. Remove belt from pulley and position temporarily around wheel rim.
3. Remove the hub cover from the wheel. **Note the wheel to shaft alignment pin under the hub cover. Insure this pin engages the notch at the end of the shaft when reinstalling the wheel.**
4. Pull the wheel straight off the shaft. **Handle wheel with care to prevent distorting of the wheel.**

25" Series

These wheels include the shaft and are secured to (2) wheel support beams by (2) flange bearings with locking collars. See Figure 4.

To install energy transfer wheel follow steps one through five below. (See Fig. 5). Reverse procedure for wheel removal.

1. Loosen the two set screws on each of the two (2) wheel bearings. See Figure 4.
2. Remove belt from pulley and position temporarily around wheel rim.
3. Remove pulley side wheel support beam with bearing, by removing (4) support beam screws.
4. Pull the wheel with shaft straight out of the motor side wheel support beam and bearing. **Handle wheel with care to prevent distorting of the wheel.**
5. When replacing wheel be certain to retighten (4) bearing set screws. Premature bearing failure could occur if neglected.

CAUTION
Disconnect electrical power before servicing energy recovery cassette

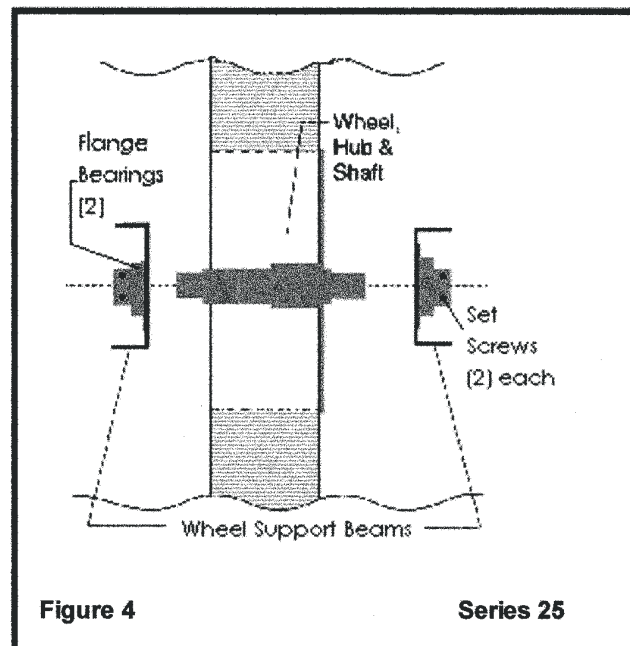
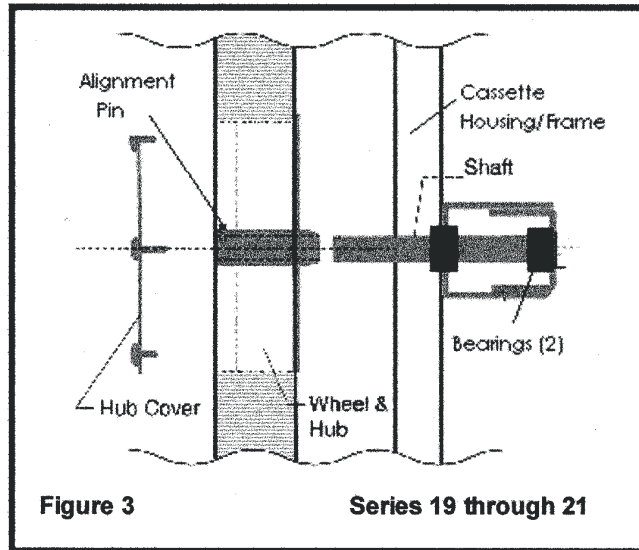

Wheel Drive Motor & Pulley Replacement

1. Disconnect power to wheel drive motor.
2. Remove belt from pulley and position temporarily around wheel rim.
3. Loosen set screw in wheel drive pulley using allen wrench and remove pulley from motor drive shaft.
4. While supporting weight of drive motor in one hand, loosen and remove (4) mounting bolts.
5. Install replacement motor with hardware kit supplied.
6. Install pulley to dimension shown in (Figure 6) and secure set screw to drive shaft.
7. Stretch belt over pulley and engage in groove.
8. Follow start-up procedure on page 4.

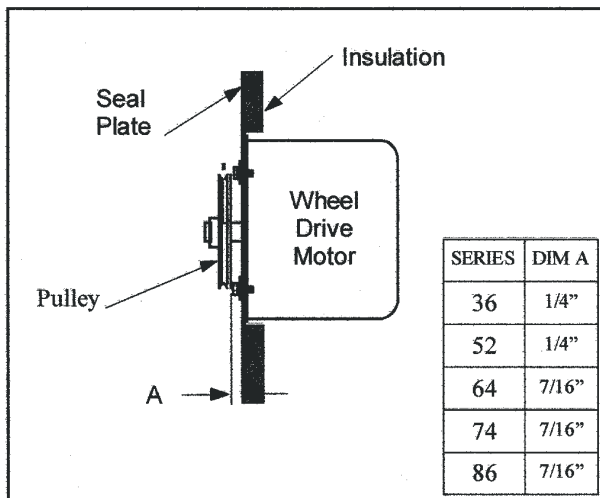

Figure 6 Pulley Location

Belt Replacement (See Figure 7)

1. Obtain access to the pulley side bearing access plate. Bearing access plates are not provided on Series 36 cassettes. Remove two bearing access plate retaining screws and the access plate.
2. Using hexagonal wrench, loosen set screw in bearing locking collar. Using light hammer and drift (in drift pin hole) tap collar in the direction of wheel rotation to unlock collar. Remove collar.

3. Using socket wrench with extension, remove two nuts which secure bearing housing to the bearing support beam. Slide bearing from shaft.
Note: Slight hand pressure against wheel rim will lift weight of wheel from inner race of bearing to assist bearing removal and installation. If not removable by hand, use bearing puller.

4. Using a wrench, remove diameter seal retaining screws (Series 36 through 74) or hub seal retaining screws (Series 86). Remove diameter seals (Series 36 through 74) or hub seal (Series 86) from bearing beam (see Fig. 9, 10 & 11).

CAUTION
Protect hands and belt from possible sharp edges of hole in Bearing Support Beam.

5. Form a small loop of belt and pass it through the hole in the bearing support beam. Grasp the belt at the wheel hub and pull the entire belt down. Loop the trailing end of the belt over the shaft (Fig. 8 & 9 shows belt partially through the opening).
6. Reinstall the bearing onto the wheel shaft, being careful to engage the two locating pins into the holes in the bearing support beam. Secure the bearing with two self locking nuts.
7. Install the belts around the wheel and pulley according to the instructions provided with the belt.
8. Reinstall diameter seals or hub seal and tighten retaining screws (see page 5 for seal adjustment). Rotate wheel in clockwise direction to determine that wheel rotates freely with slight drag on seals.
9. Reinstall bearing locking collar. Rotate collar by hand in the direction the wheel rotates (see label provided on each cassette for wheel rotation). Lock in position by tapping drift pin hole with hammer and drift. Secure in position by tightening set screw.
10. Reinstall Bearing Access Cover.
11. Apply power to wheel and ensure that the wheel rotates freely without interference.

Rx (ERV) Module

Rev.: 09/09/08B

Alternate Belt Replacement Methods

Alternate belt replacement methods may be used in some applications depending upon accessibility of the cassette. Consult instructions provided with the belt for further information.

REPLACEMENT PARTS

How to Order

Refer to the parts list and exploded view on pages 10 through 15 to obtain replacement part numbers.

Contact your MicroMetl Distributor for parts service. Order by Part Number. Serial Number (SN:) of cassette must be provided in order to verify proper part number selection. Serial Numbers are provided on product label (see Figure 7).

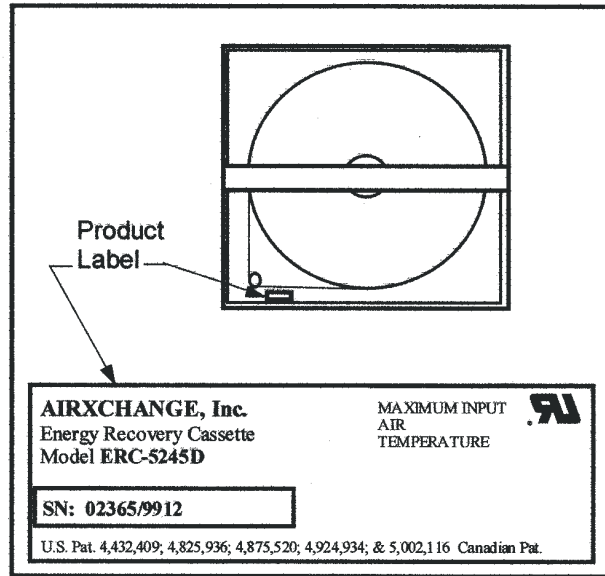

Figure 7 Product Label

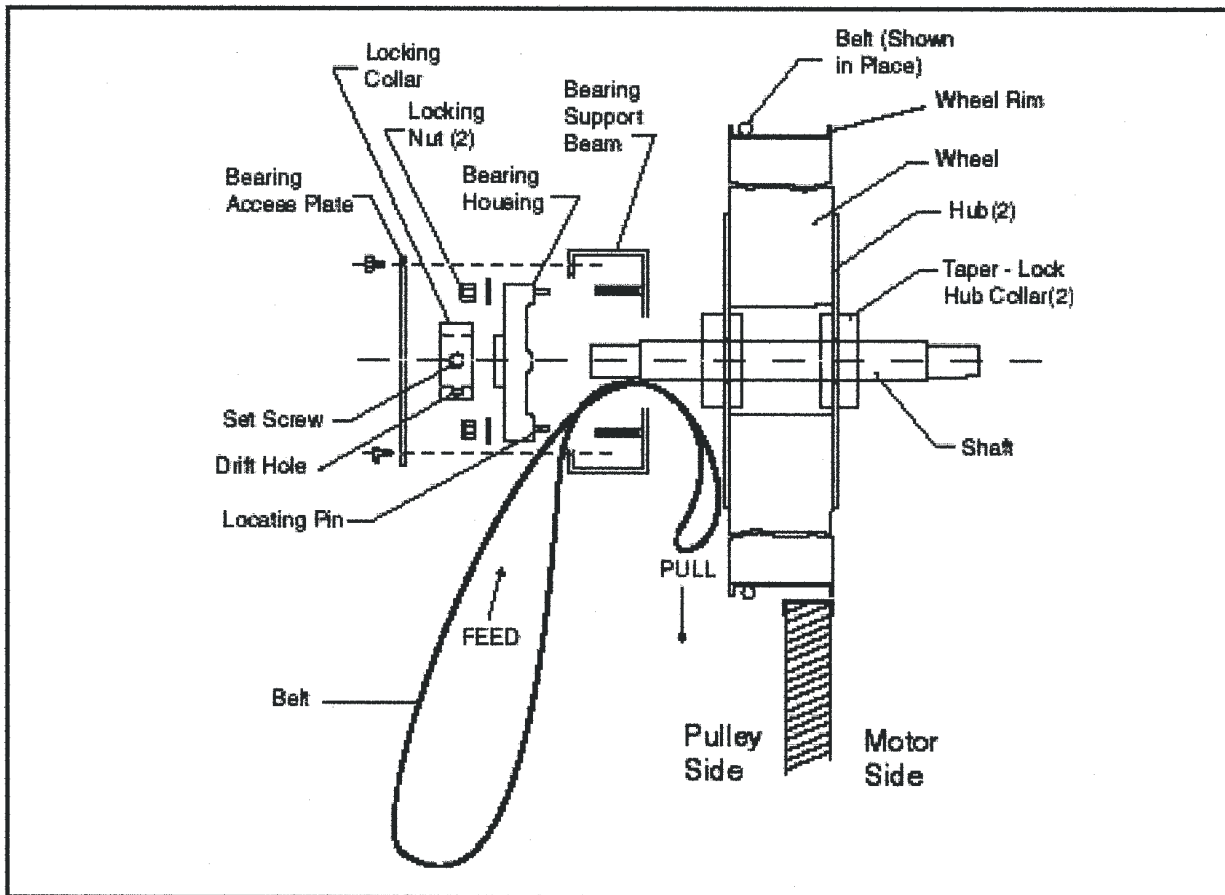

Figure 8 Belt Replacement (Figure 8 shown with diameter seals removed)

ERV Replacement Parts A Cabinet

ClimateMaster ERV Unit	ERV1014
ERV Wheel (2514 - all one piece) ERV Wheel (2513 - segmented) ERV Wheel Segment (2513 only) ERV Wheel Motor ERV Wheel Belt	9460-0010 9901-0174 9901-0175 9901-1808 9901-1810
Outside Air Blower Outside Air Blower Motor 208/230, 460v 3ph Outside Air Blower Pulley Outside Air Blower Belt Outside Air Split Taper Pulley Outside Air Motor Pulley	9901-0310 9901-0274 9901-1620 9901-1621 9901-0273 9901-0271
Exhaust Air Blower Exhaust Air Blower Motor 208/230, 460v 3ph Exhaust Air Blower Pulley Exhaust Air Blower Belt Exhaust Air Split Taper Pulley Exhaust Air Motor Pulley	9901-0310 9901-0274 9901-1620 9901-1621 9901-0273 9901-0271
Filter, 2" Outside Air (18x25x2 Qty 1) Filter, 2" Exhaust Air (18x25x2 Qty 1) Filter, Aluminum OA (12x12x1 Qty 3) Hood, Outside Air Asy - No Filters Hood, Exhaust Air Assembly Shutter, Outside Air Shutter, Exhaust Air	9460-0009 9460-0009 9460-7260 ERVAOAHOODSM ERVAEXHOODSM ERVAOASM ERVAEXSM
Locking Handle Non-Locking Handle Compression Hinge Static Pressure Tip Pressure Sensing Tip	9908-0024 9908-0025 9908-0018 9901-0301 9901-0096
Door Interlock switch Contactora, 3 pole Contactora, 1 pole (not used on VAV) 24v Relay DPDT Transformer 24 volt 208/230, 460v Transformer (460v only)	9901-0302 9901-0079 9901-1510 9901-0102 9901-0253 9901-155

Rx (ERV) Module

Rev.: 09/09/08B

ERV Replacement Parts B Cabinet

ClimateMaster ERV Unit	ERV1420	ERV2532
ERV Wheel	9460-0002	9460-0015
ERV Wheel Segment	9901-1816	9901-1817
ERV Wheel Motor	9901-0730	9901-0730
ERV Wheel Belt	9901-1811	9901-1812
Outside Air Blower	9901-0268	9901-0268
Outside Air Blower Motor		
208/230, 460v 3ph	9901-0274	9901-0277
Outside Air Blower Pulley	9901-0272	9901-0272
Outside Air Blower Belt	9901-0069	9901-0063
Outside Air Split Taper Pulley	9901-0276	9901-0276
Outside Air Motor Pulley	9901-0333	9901-0333
Exhaust Air Blower	9901-0268	9901-0268
Exhaust Air Blower Motor		
208/230, 460v 3ph	9901-0274	9901-0277
Exhaust Air Blower Pulley	9901-0272	9901-0272
Exhaust Air Blower Belt	9901-0069	9901-0063
Exhaust Air Split Taper Pulley	9901-0276	9901-0276
Exhaust Air Motor Pulley	9901-0333	9901-0333
Filter, 2" Outside Air (20x25x2 Qty2)	9460-7200	9460-7200
Filter, 2" Exhaust Air (20x25x2 Qty 2)	9460-7200	9460-7200
Filter, Aluminum OA (15x19.5x1 Qty 3)	9460-7265	9460-7265
Hood, Outside Air Asy - No Filters	ERVBOAHOODSM	ERVBOAHOODSM
Hood, Exhaust Air Assembly	ERVBEXHOODSM	ERVBEXHOODSM
Shutter, Outside Air	ERVBOASM	ERVBOASM
Shutter, Exhaust Air	ERVBEXSM	ERVBEXSM
Locking Handle	9908-0024	9908-0024
Non-Locking Handle	9908-0025	9908-0025
Compression Hinge	9908-0018	9908-0018
Static Pressure Tip	9901-0301	9901-0301
Pressure Sensing Tip	9901-0096	9901-0096
Door Interlock switch	9901-0302	9901-0302
Contactactor, 3 pole	9901-0079	9901-0079
Contactactor, 1 pole (not used on VAV)	9901-1510	9901-1510
24v Relay DPDT	9901-0102	9901-0102
Transformer 24 volt		
208/230, 460v	9901-0253	9901-0253
Transformer (460v only)	9901-1559	9901-1559

ERV Replacement Parts C Cabinet

ClimateMaster ERV Unit	ERV3650	ERV5060
ERV Wheel ERV Wheel Segment ERV Wheel Motor ERV Wheel Belt	9460-0005 9901-1818 9901-1819 9901-1813	9460-0013 9901-1820 9901-1819 9901-1814
Outside Air Blower Outside Air Blower Motor 208/230, 460v 3ph Outside Air Blower Pulley Outside Air Blower Belt Outside Air Split Taper Pulley Outside Air Motor Pulley	9901-0286 9901-0361 9901-0326 9901-0065 9901-0276 9901-0328	9901-0286 9901-0108 9901-1688 9901-0088 9901-0276 9901-1535
Exhaust Air Blower Exhaust Air Blower Motor 208/230, 460v 3ph Exhaust Air Blower Pulley Exhaust Air Blower Belt Exhaust Air Split Taper Pulley Exhaust Air Motor Pulley	9901-0286 9901-0361 9901-0326 9901-0066 9901-0276 9901-0328	9901-0286 9901-0108 9901-1534 9901-1776 9901-0276 9901-1535
Filter, 2" Outside Air (16x20x2 Qty 6) Filter, 2" Exhaust Air (16x20x2 Qty 6) Filter, Aluminum OA (20.25x22.5x1 Qty 5) Hood, Outside Air Asy - No Filters Hood, Exhaust Air Assembly Shutter, Outside Air Shutter, Exhaust Air	9460-6010 9460-6010 9460-7270 ERVCOAHOODSM ERVCEXHOODSM ERVCOASM ERVCEXSM	9460-6010 9460-6010 9460-7270 ERVCOAHOODSM ERVCEXHOODSM ERVCOASM ERVCEXSM
Locking Handle Non-Locking Handle Compression Hinge Static Pressure Tip Pressure Sensing Tip	9908-0024 9908-0025 9908-0018 9901-0301 9901-0096	9908-0024 9908-0025 9908-0018 9901-0301 9901-0096
Door Interlock switch Contactor, 3 pole Contactor, 1 pole (not used on VAV) 24v Relay DPDT Transformer 24 volt 208/230, 460v Overload Thermal Protection Transformer (460v only)	9901-0302 9901-0079 9901-1510 9901-0102 9901-0253 na 9901-1536	9901-0302 9901-0079 9901-1510 9901-0102 9901-0253 na 9901-1536

Rx (ERV) Module

Rev.: 09/09/08B

ERV Replacement Parts D Cabinet

ClimateMaster ERV Unit	ERV6585
ERV Wheel ERV Wheel Segment ERV Wheel Motor ERV Wheel Belt	9460-0016 9901-1821 9901-1809 9901-1815
Outside Air Blower Outside Air Blower Motor 208/230, 460v 3ph Outside Air Blower Pulley Outside Air Blower Belt Outside Air Split Taper Pulley Outside Air Motor Pulley	9901-1600 9901-1502 9901-1583 9901-1742 9901-0276 9901-1741
Exhaust Air Blower Exhaust Air Blower Motor 208/230, 460v 3ph Exhaust Air Blower Pulley Exhaust Air Blower Belt Exhaust Air Split Taper Pulley Exhaust Air Motor Pulley	9901-1600 9901-1502 9901-1583 9901-1743 9901-0276 9901-1741
Filter, 2" Outside Air (20x24x2 Qty 6) Filter, 2" Exhaust Air (20x24x2 Qty 6) Filter, Aluminum OA (25x33x1 Qty 5) Hood, Outside Air Asy - No Filters Hood, Exhaust Air Assembly Shutter, Outside Air Shutter, Exhaust Air	9460-7250 9460-7250 9460-7275 ERVDOAHOODSM ERVDEXHOODSM ERVDOASM ERVDEXSM
Locking Handle Non-Locking Handle Compression Hinge Static Pressure Tip Pressure Sensing Tip	9908-0024 9908-0025 9908-0018 9901-0301 9901-0096
Door Interlock switch Contactor, 3 pole 24v Relay DPDT Transformer 24 volt 208/230, 460v Overload Thermal Protection	9901-0302 9901-0079 9901-0102 9901-0253 9901-1515

ERV Additional Replacement Parts

Description	ClimateMaster Part No.
<u>Frost Protection</u> Time delay relay Pressure switch	9901-0292 9901-0509
<u>Remote Timer</u> Remote Micro Programmer	9901-0512
<u>ERV Filter Maintenance Switch</u> Pressure Switch	9901-0509
<u>Temp Lockout</u> Temperature switch	9901-0517
<u>Wheel Bypass</u> Logic module Enthalpy sensor Dry bulb sensor	9901-0017 9901-0018 9901-0251
<u>Stop Jog</u> time delay relay	9901-0540
<u>Fan Delay Timer</u> time delay relay	9901-0292
<u>Airflow Monitor</u> Photohelic gage	9901-0756
<u>2 Position Dampers</u> Motor (for all except D cabinet OA) Motor for D cabinet OA Balance switch (n.o.)	9901-0240 9901-0083 9901-0006

ERV Pre-heater Parts

Heater Size	A Cabinet	B Cabinet	C Cabinet	D Cabinet
5kw 230v 460v	9901-1736 9901-1824	9901-1842 9901-1843		
10kw 230v 460v		9901-1737 9901-1703	9901-1738 9901-1828	9901-1831 9901-1832
15kw 230v 460v			9901-1829 9901-1794	9901-1834 9901-1835
20kw (19 kw) 230v 460v				9901-1837 9901-1838

Rx (ERV) Module
 Rev.: 09/09/08B

Revision History

Date:	Item:	Action:
09/09/08	Decoders	Updated
01/01/06	First Published	



97B0042N01



7300 S.W. 44th Street
 Oklahoma City, OK 73179
 Phone: 405-745-6000
 Fax: 405-745-6058
 climatemaster.com

ClimateMaster works continually to improve its products. As a result, the design and specifications of each product at the time of order may be changed without notice and may not be as described herein. Please contact ClimateMaster's Customer Service Department at 1-405-745-6000 for specific information on the current design and specifications. Statements and other information contained herein are not express warranties and do not form the basis of any bargain between the parties, but are merely ClimateMaster's opinion or commendation of its products. For the latest version of this document go to climatemaster.com.