

# ProMAX™

## Cast Iron Router Table

Stock No. 40-031

Thank you for purchasing our ProMAX cast iron router table. ProMAX can be mounted to your table saw, cabinet, or open steel stand. The optional cast iron end cap (Stock No. 40-044) can be added to give your router table a finished look with 4" more table depth and rounded corners. Or, bolt two router tables together - back to back. You must fabricate your own stand or cabinet. For those mounting the ProMAX to the right of your saw blade, and not directly to the table saw's table, you must have a t-square type rip fence with heavy steel rails to support the router table. Also, you must fabricate your own support legs, or modify your existing legs.

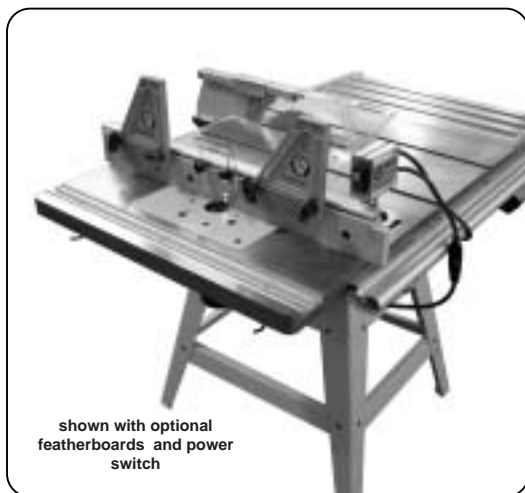

shown with optional featherboards and power switch



**Bench Dog, Inc.**  
3310 5th St. NE  
Suite 100  
Minneapolis, MN 55418

612.782.8205 main  
612.788.2518 fax  
800.786.8902 toll free  
info@benchdog.com  
www.benchdog.com

QUESTIONS?

**1-800-786-8902**

Be sure to check out our web site for all the latest and greatest accessories and tools.

**www.benchdog.com**

Maximum versatility...

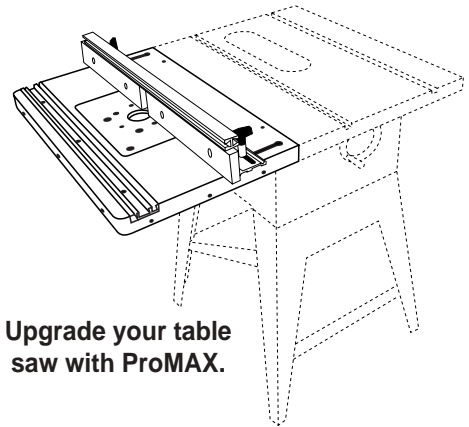

Upgrade your table saw with ProMAX.

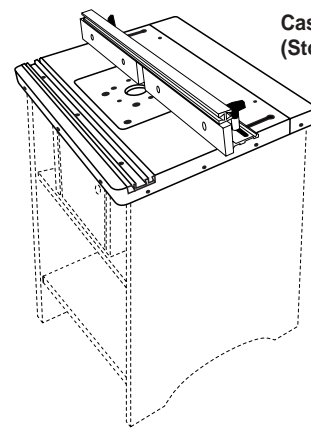

Cast Iron End Cap (Stock No. 40-044)

Purchase our 4" x 27" cast iron end cap and mount the router table to a cabinet!

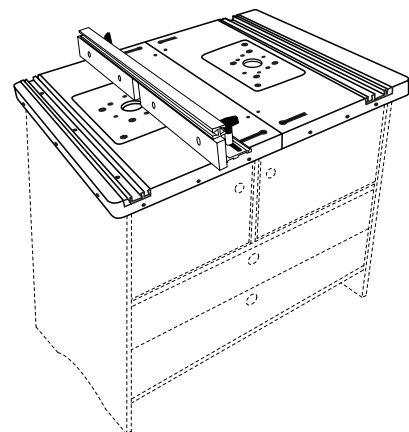

ProMAX - back to back. The ultimate tandem router table. Perfect for professional woodshops, and commercial rail and stile production.

Read and understand the entire contents of this manual before attempting assembly or operation of this tool! Inspect contents for shipping damage and shortages. Report problems directly to Bench Dog, Inc.

# Contents of Box



- 1 cast iron routertop
- 1 28" ProFence
- 1 predrilled phenolic insert plate
- 1 accessory/miter track

## Fence Hardware

- 2 3/8-16 x 2-1/2" hex bolts
- 2 3/8" nylon washers
- 2 2" t-knobs
- 2 1/4-20 x 3/4" hex bolts
- 6 1-1/8" t-knobs
- 4 1/4-20 x 40mm shoulder bolts
- 1 dual position bit guard
- 1 dust port
- 2 MDF subfences
- 2 aluminum knob spacers
- 2 aluminum jointer bars (pair)
- 2 j-hooks

- 1 owner's manual
- 1 templaе (paper)

## Router Table Hardware □

- 3 heavy rectangular shape washers
- 3 M10 x 1.5 x 40mm hex bolts
- 3 7/16-20 x 1-1/2" hex bolts
- 4 5/16-18 x 1-1/2" hex bolts
- 8 5/16" flat washers
- 4 5/16" lock washers
- 4 5/16" hex nuts
- 10 1/4-20 x 1" set screws
- 12 1/4-20 hex nuts
- 13 1/4-28 x 1/2" set screws
- 3 1/4-20 x 5/8" low head cap screws
- 2 1/4-20 x 1" phil. flat head machine screw (black)

# General Conditions / Limited Two Year Warranty

## LIMITED TWO-YEAR WARRANTY

We make every effort to assure that our products meet quality and durability standards, and warrant to the original retail purchaser that this product is free from defects in materials and workmanship for two years. Remedy shall be limited to Bench Dog's choice of repair, replacement or refund. This warranty does not provide remedy for consequential economic loss.

This is a limited two year warranty. It requires the purchaser to contact Bench Dog in writing within 30 days of discovering the defect. Warranty does not apply to defects due directly or indirectly to misuse, abuse, negligence or accidents, repairs or alterations, or due to lack of maintenance. It excludes components and parts not manufactured by Bench Dog, defects caused by failure to provide a suitable installation environment, and damage caused by use for purposes other than those for which the product was designed. Bench Dog, Inc. reserves the right to make product changes without notice and without obligation to make these changes on products previously sold. It excludes warranties of fitness for a particular purpose.

If the product is defective, we reserve the right to fix it, replace it, or refund the cost of the product to you. Typically, this results in a refund. All claims are limited to the two-year claims period. We must receive the product before a credit or refund will be issued. The warranty language on the product or in the product's manual may contain additional limitations, which govern.

If you wish to return something, call the dealer where you purchased the product. If you wish to return something purchased from Bench Dog directly, call 1-800-786-8902 to receive an RMA number. Upon receipt and inspection of the goods, a credit or replacement will be issued for defective products. Return of nondefective items to Bench Dog are subject to a 7% restocking charge. This is necessary due to the cost of checking, repackaging, and inventorying the stock.

BENCH DOG DISCLAIMS AND BUYER EXPRESSLY WAIVES ANY AND ALL WARRANTIES, EXPRESS OR IMPLIED, INCLUDING BUT NOT LIMITED TO, IMPLIED CONDITIONS OF FITNESS FOR A PARTICULAR PURPOSE, MERCHANTABILITY, OR ANY OTHER MATTER.

## Important Safety Points

Before operating your router table please read this manual thoroughly. **Safety and use tips are contained in the manual. This page is not the sole source of safety information.** Retain the manual for future reference. Refer to your router owner's manual for safety instructions regarding use of that tool. This manual is not an instruction book on how to do woodworking with a power tool. We encourage all woodworkers to continually seek improvement in their woodworking skills, regardless of their craftsmanship or years of experience. The router table, fence and accessories must only be used for their intended purpose: woodworking via normal routing operations. "Normal operations" means basic shaping of wood in conditions where grounded electricity, sharp tools, dust, and rapidly spinning parts can be used or encountered safely. The following instructions elaborate on this concept.

1. Do not use your router table as a step or seat.
2. The top and cabinet must be properly secured, and be level before use. Inspect your table and base for damage and levelness prior to each use.
3. Keep work area clean, dry and well lit.
4. The hardware affixing the insert to the routertop must be installed for safe use. Tighten insert hold-down screws before each use.
5. Safe operation requires a router table fence, bit guard, dust collection system, starting pin or fulcrum, and speed reducer for large diameter bits. We recommend reducing router speed for 1" or larger diameter bits. Consult your bit manufacturer for the exact speed.
6. Use the right tool for the job. Do not force a tool or attachment to do a job for which it was not designed.
7. Secure your work with a featherboard, clamps, or a vice when appropriate. The use of inappropriate accessories may cause injury.
8. Wear safety glasses, dust mask, face shield and ear protection. This is not an exhaustive list. Every-day eye glasses do not substitute for safety glasses.
9. Do not wear gloves or jewelry while using a power tool and ProMAX
10. Maintain your equipment and its accessories in good working condition. Look for wear, poor alignment of moving parts, binding of moving parts, breakage, poor mounting, or other conditions that may affect operation and safety. Repair or replace any damaged parts.
11. Disconnect the power before moving, adjusting, or repairing parts, or otherwise maintaining your router table and any accessories you may be using.
12. Keep children, pets, and those who may disregard safety away from work area, cords, sockets and tools.
13. Wear snug fitting clothes and keep long hair back to avoid catching in moving parts.
14. Do not overreach. Maintain balanced footing and stance.
15. Stay alert. Use common sense.

# Assembly Instructions

The following instructions only apply to mounting the ProMAX directly to a cast iron table saw. The pictures show a RIDGID (very similar to Craftsman) brand table saw. ProMAX will fit on any cast iron table saw with at least 27" table depth. Tables deeper than 27" will require shims to fill the space between your fence rails and the ProMAX.

**Note:** ProMAX can not be installed as a left extension replacement on left tilt "cabinet" grade table saws because the table saw's motor protrudes to the left. Nor can ProMAX be installed as a right extension replacement on right tilt "cabinet" grade table saws for the same reason. Mounting ProMAX to the far right will avoid the protruding motors, however, ProMAX must be supported with the two steel rails that also support your T-square style rip fence and legs.



## 1. Remove the factory left extension wing.

Use the hardware that came with your ProMAX to install your router table. Do not use the factory bolts, as they may not be grade 5 or the proper length. If the necessary bolt size is not supplied with this router table you must purchase your own grade 5 bolts.



In most cases the fence rails support the factory table extension wings. When bolted directly to your table saw, ProMAX requires no support from the fence rails. Therefore, fence rails do not need to be fastened to ProMAX.

## 2. Determine your saw's bolt pattern.

Craftsman and Ridgid use a four bolt pattern. Most all other saws use a three hole pattern.

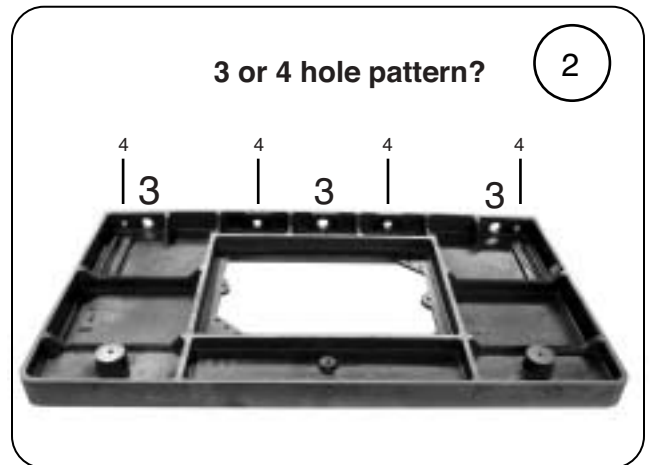

## 3. Four hole mounting.

Most four hole patterns use 5/16 bolts. Use the heavy rectangle washers for the middle two holes, as shown. Each bolt receives (2) 5/16" flat washers, (1) lock washer, and (1) nut. Late model Ridgid saws use 5/16-18 tapped holes instead of through holes. If the bolt size is not 5/16-18, you must supply your own. Use grade 5 bolts.

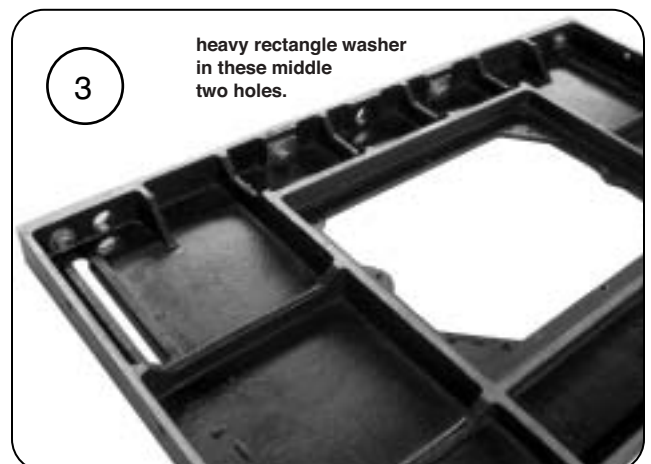

Middle two bolts receive the heavy rectangle washers against the router table



WASHER ORIENTATION (bottom of table)



#### 4. Three bolt applications.

This pattern always uses the heavy rectangle washers on each bolt. Delta brand uses the 7/16-20 x 1-1/2 hex bolts. Most others (imports) use the M10 x 1.5 x 40mm hex bolts. If your bolt size was not mentioned you must purchase your own. Only use grade 5 bolts.



#### 5. Install the insert plate leveling screws.

Install, as shown. Use the 1/4-20 x 1" set screws and 1/4" nuts. You will adjust and tighten these screws in steps 8 and 9.

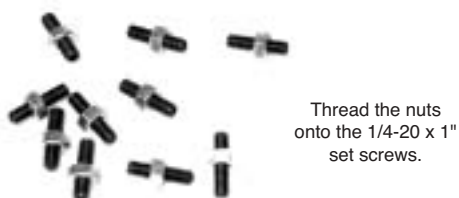

#### 6. Lift the router table into position.

Install the bolts while a friend holds the table in position. Just snug the bolts for now. **Make absolutely certain both surfaces are smooth, flat, and free of burrs before mating the two tables together!**



#### 7. Tighten the router table.

Tighten the bolts gradually and evenly. Use a soft tipped mallet to lightly tap the table surfaces. If your router table is not flat with your table saw's table, you may need to shim it. Use paper or brass shims. The tolerances of your ProMAX are probably much higher than those of your table saw's. Slight inaccuracies in alignment rarely pose a significant problem.





### 8. Adjust leveling screws until insert plate is flush.

Install the insert plate into the routertop. Adjust leveling screws until the plate is flush with routertop. You will mount your router in step 16.

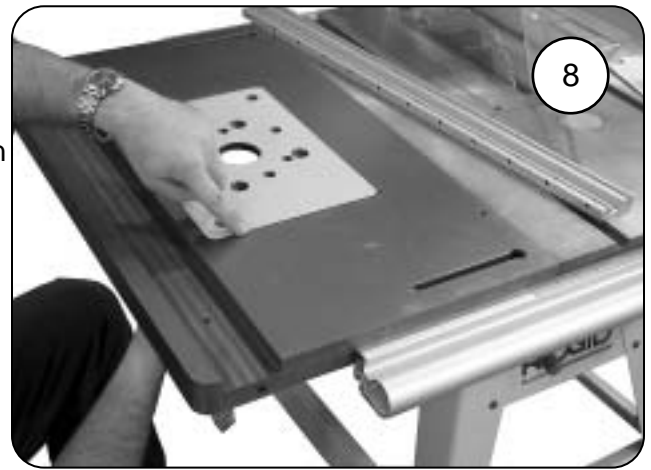

### 9. Tighten the levelers.

Hold the leveler with the 1/8" hex wrench, and use your 7/16" wrench to tighten the nut. This will prevent the assembly from moving. Be sure to hold the hex wrench securely when tightening the nut. It may be necessary to fine tune the adjustment after installing your router.



### 10. Adjust miter gauge track to fit your miter gauge.

First test-fit your miter gauge into the track. If it's too tight, squeeze the gib against the front wall of the miter track with a pair of Channel Locks. Use something to prevent marring the aluminum. Next, install the (12) 1/4-28 x 1/2" set screws. Tightening the screws will deflect the gib into your miter gauge. Tighten all screws uniformly and gradually until the desired fit is achieved. **Miter gauge NOT INCLUDED.**

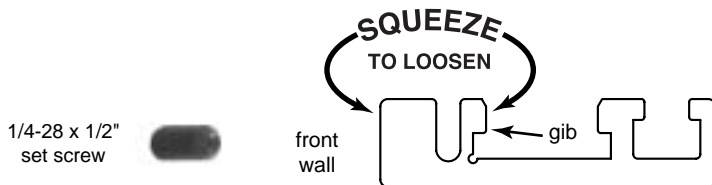

**This miter track ONLY fits standard 3/8" x 3/4" miter gauge bars. Wax the slot and bar to reduce wear.**

### 11. Install the accessory/miter gauge track.

Use the (3) 1/4-20 x 5/8 low head cap screws. Tighten with the 1/8" hex wrench.



## 12. Install dust port.

Pull the dust port along the two 45° grooves in the back of the fence until it snaps into place. The port may fit very tightly.



## 13. Install the (2) MDF subfences onto the fence.

Insert (4) 1/4-20 x 40mm shoulder bolts into the counter-bored recess on the subfences. Light pressure may be required to seat bolts properly. The bolts are designed to fit snugly to prevent spinning. Note: the subfences have no specific left/right or up/down orientation.



## 14. Attach fence.

Use the (2) 3/8-16 x 2-1/2" hex bolts, (2) aluminum knob spacers, (2) 3/8" nylon washers and (2) 3/8" (large) T-knobs.

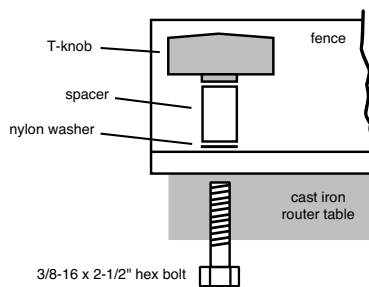

## 15. Attach the dual position bit guard to fence.

Pre-assemble the guard with the (2) 1/4-20 x 3/4" hex bolts and (2) knobs. Slide both bolt heads into the fence's T-slot to attach to fence.

Note: The bit guard is designed for dual positioning. The larger, curved side is used for general routing with small and medium sized bits. The smaller angled side is intended for edge jointing and small diameter bits.

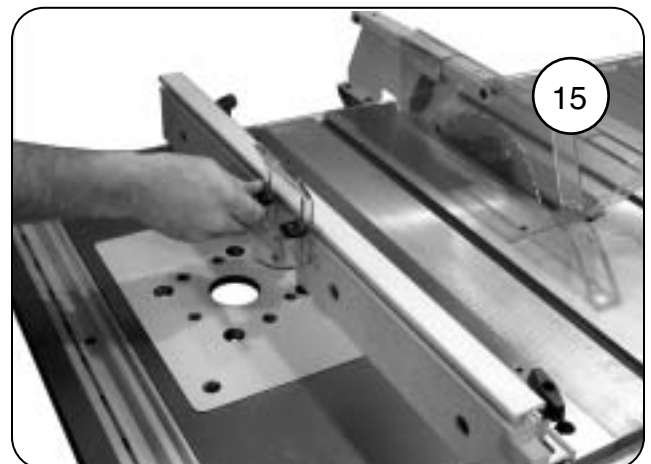

### 16. Mount router to the insert plate.

This insert plate is predrilled to fit most popular routers, and comes with proper mounting screws for these routers. In some cases, you must drill your own holes and purchase your own mounting screws. Please reference the included template to complete this step.

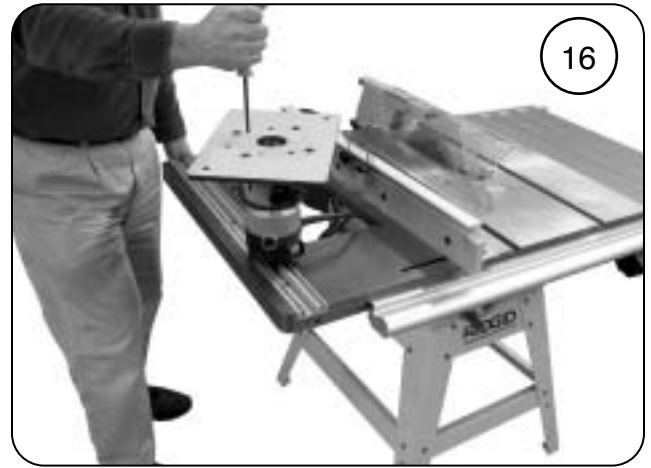

### 17. Install router and plate into the routertop.

Re-adjust the insert plate flush if necessary (see step 8). Install the (2) 1/4-20 x 1" flat head phillips screws into the two corners of the insert plate. These screws prevent side-to-side movement and keep the insert plate firmly seated while preventing excessive vibration. Do not over tighten as this could damage the insert plate.



1/4-20 x 1" (black)  
flat head phillips  
machine screw



**Check the tightness of the hold-down screws before each use!**



### 18. Install fence hang hooks.

Screw the hooks into the table about 3/8" and tighten the 1/4" jam nuts with a 7/16" wrench.

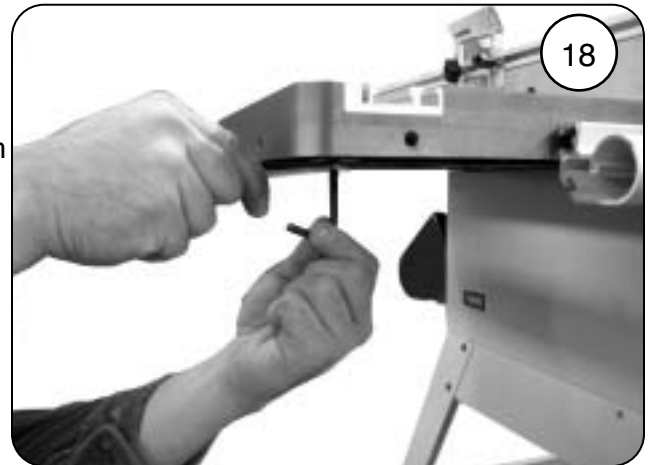

### 19. Hang the fence when not in use.





# Operational Tips

## File Sharp Edges

Some table saws have a bevel on the leading edge. You can file your router table to match, if so desired.



## Dust Collection

The integral dust collection port is designed to accept a standard 2-1/2" fitting, typical on most shop vacs. Most of these fittings actually measure 2-1/4" (outside diameter). Bench Dog recommends 2-1/2" hose, or larger, because it is more effective at evacuating dust and chips, and provides proper air flow over the router motor. Any hose larger or smaller than 2-1/2" requires an adapter you must provide. If additional dust collection is needed, a dust port can be added to your cabinet or motor area. **DO NOT USE YOUR ROUTER TABLE WITHOUT DUST COLLECTION!**



## Using Your Miter Gauge

The miter track has two slots: an accessory T-slot and a T-bar compatible miter gauge slot. The accessory T-slot is the narrower of the two. It accepts 1/4" hex bolts for attaching Feather-Loc featherboards. The miter gauge slot is used in conjunction with a miter gauge, and fits standard 3/8" x 3/4" miter bars (with or without the T-bar). The miter gauge is not included.

To adjust fence perpendicular to miter gauge, set miter gauge to 90°, and place in slot (make sure miter track is adjusted, see step 10). Loosen the fence's T-knobs and align the miter gauge to fence using a square, as shown.



## Feed Direction

Always feed the workpiece *against* the cutter rotation, as shown. Feeding the workpiece *with* the cutter rotation is called "climb cutting". Climb cutting is **very dangerous**, because the cutter will grab the workpiece and thrust it the same direction as the cutter rotation. Even small router bits will overpower your ability to hold onto the workpiece during a climb cut.

Do not use this router table until you understand proper feed direction and bit rotation. If climb cutting is still unclear, ask your retailer for help, give us a call, or reference a book on router table usage.



**Never Climb Cut!**

*A typical set-up. Here, the fence is partially covering the router bit.*

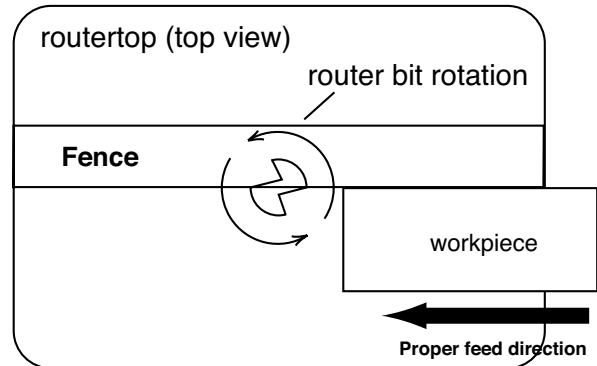

## Avoiding Fence Traps

Fence traps occur when the work piece is fully "trapped" between the router bit and fence. Fence traps pose two real concerns: the possibility of climb feeding, and human exposure to the router bit. As stated earlier, climb cutting should be avoided as loss of control of the operation is a possibility!

The top drawing shows a classic trap to be avoided. What appears as a normal feed direction (working from right to left) is wrong, and will instead produce a climb cut. Because the work piece is trapped it can easily be pulled from one's grip and thrown with great velocity. Feeding the stock from left to right will eliminate the climb cut but not the danger. It will be difficult to keep the stock tight against the fence as the bit's rotation will thrust the stock away from the fence. Also, your body will be dangerously exposed to the spinning router bit. The bit guard will not protect you against flying stock, nor guard against this level of exposure.

The second drawing is not a trap, as long as the router bit cuts only partially into the stock. In other words, the router bit must not completely cut through the workpiece. In this cut, the bit will grab and push the stock toward the fence. This is good, as the fence will control the workpiece better than your hands. Typical dado cuts resemble this set-up, and are commonly performed on router tables. If the dado is to be widened with two (or more) passes, be careful not to set a classic trap or climb cut.

*A classic trap resulting in a climb cut. Always avoid this set-up!*

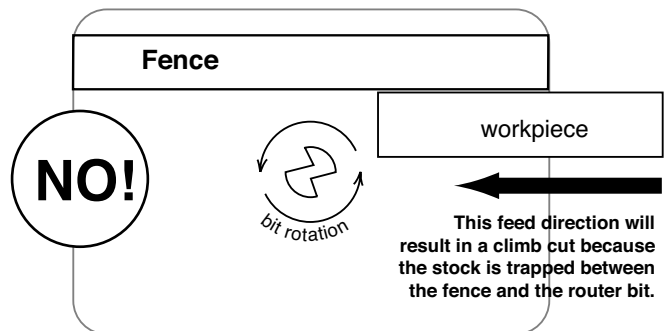

*Not a trap as long as the router bit does not cut all the way through the stock.*

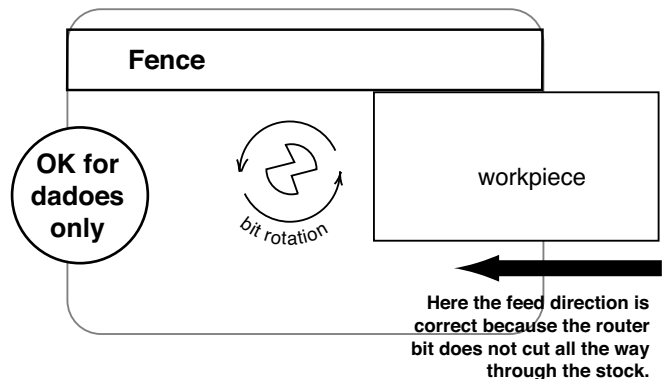

## Adjusting the Subfences

The (2) MDF (medium density fiberboard) subfences are designed to slide along the fence approximately 2". This results in a router bit opening from 0 to 4".

### A. "Close" Setting

Many applications require adjusting the subfences close to the router bit. This accomplishes nearly the same benefits of a true "zero clearance" setting (see "B") without cutting the subfences. Before the router is turned on, and after the fence and router bit height are properly adjusted, slide the subfences toward the bit to reduce the gap. **Confirm that the router bit can freely rotate without touching the subfences!**

### B. "Zero Clearance" Setting

Cutting the subfences into the router bit profile produces "zero clearance". Zero clearance eliminates the gap between the fence and router bit. This prevents the workpiece from getting pulled into the fence just before the router bit. Moreover, a zero clearance setting achieves a cleaner cut because the subfence supports the workpiece fibers. If a true zero clearance setting is desired, follow these steps:

1. Adjust the bit height and fence position. Note: the subfences must NOT contact the router bit at this time.
2. Install the bit guard and secure.
4. Start router, and use dust collection. From the back of the fence, slightly loosen the subfence knobs and carefully slide the infeed subfence into the spinning router bit. Hold onto the subfence knobs.
5. After the subfence has reached the guide bearing of the router bit, fully tighten the knobs on the subfence. Note: If the bit does not have a guide bearing (i.e. vertical raised panel bits), slide the subfence half-way into the bit, then tighten the subfence knobs.



**Caution: Never adjust or slide the subfences from the front! Always work from the back with both hands on the adjustment knobs.**



The infeed subfence is wide open, and the outfeed subfence is set to "close".

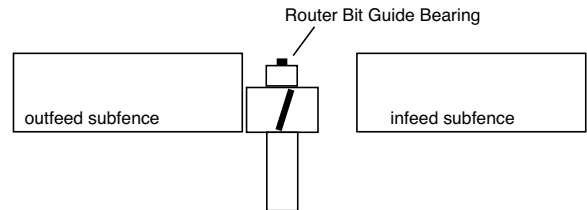

Here the infeed subfence has been adjusted to zero clearance.

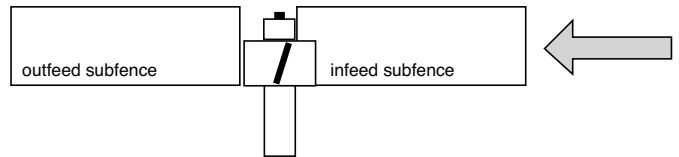

#### Important Notes:

The outfeed subfence is rarely set to zero clearance, because doing so has little performance benefit and can damage the subfence. A "close" setting is more desirable for most applications. Setting the outfeed subfence to zero requires great care because the router bit can cause a portion of the subfence to chip or break. If an outfeed zero clearance is absolutely necessary, slide the outfeed subfence very slowly into the bit to minimize the chipping and tearing.

The subfences can be flipped when changing profiles or bit heights. New, replacement subfences are available when a new profile is to be created or if the subfence cannot be trimmed to provide a fresh edge.

MDF works very well as a subfence because it is softer than most woods and is much less likely to damage expensive router bits. MDF also retains the shape of delicate profiles and thus allows proper support for zero clearance settings.

When adjusting the fence, ensure that no part of the aluminum fence body could contact the router bit.

## Jointing

Jointing is the process of making flat, square and straight mating edges. Jointing is necessary when two boards are edge glued to create a larger panel. It is also used to "fit" pieces together, as well as to trim stock to size.

Note: Jointing on a router table is not intended to replace a free-standing power jointer, especially for stock wider than 1.25". However, jointing with the router table does have advantages over the jointer. First, small and short pieces of wood can be safely jointed because the opening of the fence can be made very small: about 1/2". Second, the quality of the cut is usually better because the router bit spins much faster than the jointer's cutter head. A faster cutter speed is especially useful on woods prone to tear-out, like bird's eye maple and quilted cherry. Be sure not to move too slowly, as this will leave burn marks in your workpiece.

Your fence has built-in jointing slots to accept the (2) small aluminum jointer bars that shipped with your router table. Installed in pairs, these bars "shim out" the out feed subfence either 1/32" or 5/64" (2mm).

## Set-up

Unplug router and install a 1/2" diameter straight or spiral up-cut router bit.

**Caution: Use only 1/2" shank bits for jointing. The bit's cutting length must not exceed 1.25". Set the bit height to 1.25" or less.**

Loosen the outfeed subfence mounting knobs and slide both aluminum jointer bars (always installed in pairs!) under the outfeed subfence in either the 2nd and 4th slots, or the 1st and 3rd slots (see illustration).

Use a straight edge to adjust the router bit and outfeed subfence to the same plane (see illustration below). Readjust if necessary. Remove straight edge when done.

Slide both subfences toward the bit to decrease the amount of gap around the router bit. Be sure the subfences are not touching the router bit. Also be sure the router bit is not touching the fence's aluminum body. Tighten the subfence knobs and place the bit guard in position.

First make a test cut in scrap stock. Readjust if necessary.



In this photo, the user is sliding the second bar into position. Be sure to tighten the subfence knobs when done!

Note the small "v" grooves. Always install the bars in pairs.

Use slots 1 and 3 for 5/64" (2mm) cuts.

Use slots 2 and 4 for 1/32" cuts.

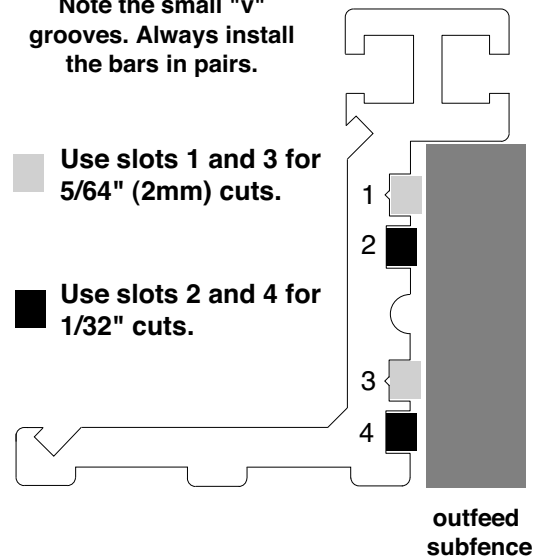

If board "snipe" occurs, realign the outfeed subfence to the router bit. Don't be surprised if it takes a few tries to master this operation.

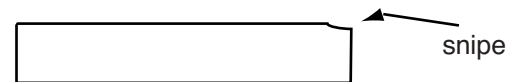

(Bit guard not shown for clarity, only!)

